

This unit offers anti-siphon and non-rupture protection.

The freezeless Model 19 is intended for irrigation purposes and designed for year-round residential regardless of outside temperature. This product contains an integral backflow protection device which protects up to 125 psi of backpressure and therefore does not require an add-on vacuum breaker.

SPECIFICATIONS:

- Manufactured under one or more of the following patents: 3,208,715; 3,278,201; 5,590,679; 5,632,303; 6,142,172; 6,532,986 and patents pending
- ASSE 1019 - Type C Listed
- CSA, cUPC Approved
- Not intended for continuous use



FEATURES:

- *Patented resetting pressure relief valve prevents the faucet tube from bursting in freezing conditions even if a hose is unintentionally left on.*

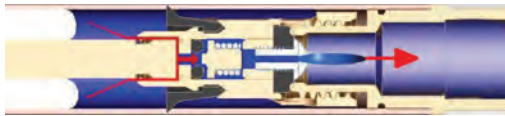

- 3/4" male hose thread nozzle
- Stainless steel seat - eliminates wire draw
- EPDM packing to prevent leaking
- Full circle operating threads on valve body and retainer
- No-lead solder
- Standard "O" size seat washer
- Oval, powder-coated, die cast aluminum handle
- Optional Tee Key available (extra charge)
- Adjustable polycarbonate wall flange
- **MAX PRESSURE** - 125 p.s.i.
- **MAX TEMPERATURE** - 120° F

INSTALLATION REQUIREMENTS:

- The faucet length used is to be comparable to what would be used with standard freezeless faucets.
- The inlet connection must be located in a heated area.
- The gap between the house and faucet must be sealed to prevent air leaks.
- The faucet must be installed with a slight downward pitch toward the nozzle.
- Adequate insulation is required around the faucet, wall board and sill plate.

For Installation / Troubleshooting Instructions go to www.woodfordmfg.com or call 1-800-621-6032

Freezeless Anti-Siphon Wall Faucet Model 19



Inlet Descriptions

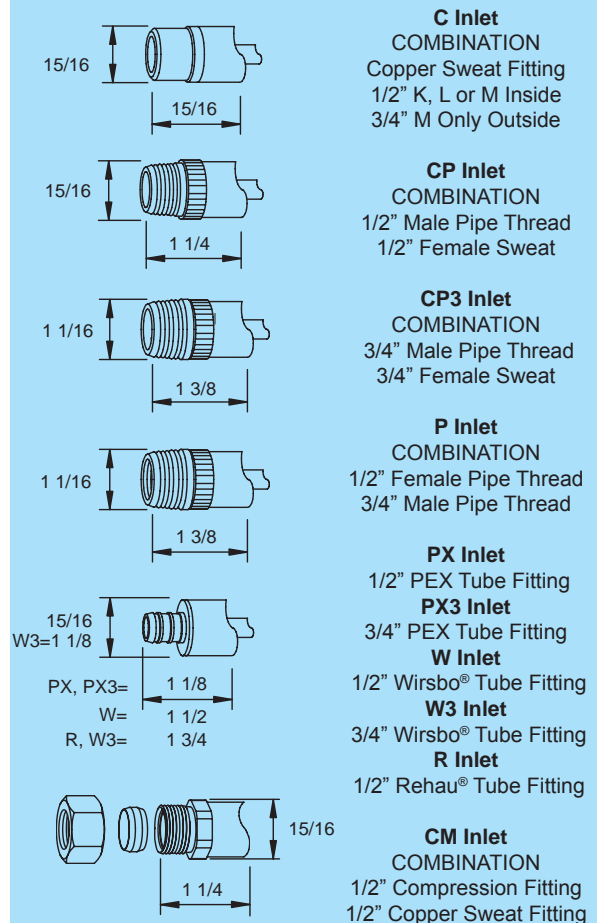

When ordering, specify model , inlet and wall thickness.

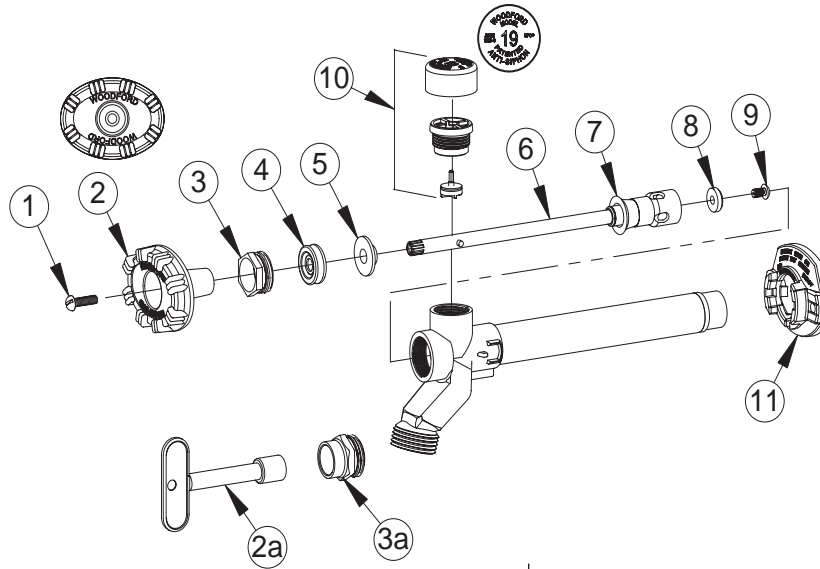

MODEL 19 PARTS LIST

ITEM	PART#	DESCRIPTION
1	30002	Handle Screw
2	30559	Oval Wheel Handle - Powder Coated Die Cast Aluminum
2a	50012	Tee Key (Optional)
3	30059	Packing Nut
3a	30512	Packing Nut w/deep stem guard (Optional)
4	30560	EPDM Packing
5	30421	Packing Support Washer
6	RK-PRV	Valve Stem Assembly (See chart at right)
7	30459	Check Valve
8	30008	Valve Seat Rubber
9	30804	Retainer Screw
10	RK-19VB	Vacuum Breaker Float Kit - Model 19
11	30098	Adjustable Flange
	RK-19	Repair Kit (Includes items 1-5, 7-10)

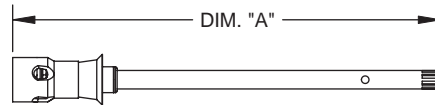

RK-PRV DIM "A"	
Wall Thickness	Overall Length
4	5 7/8"
6	7 7/8"
8	9 7/8"
10	11 7/8"
12	13 7/8"
14	15 7/8"
16	17 7/8"
18	19 7/8"
20	21 7/8"
22	23 7/8"
24	25 7/8"

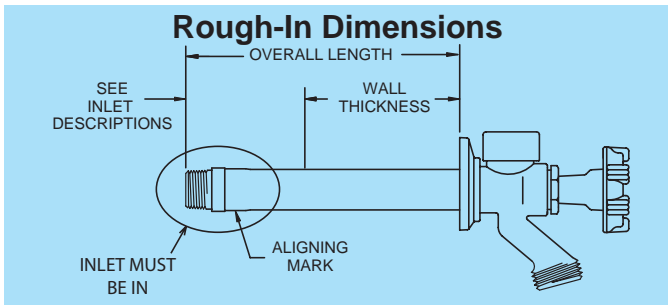

Wall Thickness (inches)											
4	6	8	10	12	14	16	18	20	22	24	
1.2	1.3	1.4	1.5	1.6	1.7	1.8	1.9	2.0	2.1	2.2	

Shipping Wt. Ea. (lbs)

*Overall Length Dimension: Add wall thickness and inlet option length shown in chart above.

For more information contact...

WOODFORD MANUFACTURING COMPANY

2121 Waynoka Road, Colorado Springs, Colorado 80915 • Phone: (800) 621-6032 • Fax: (800) 765-4115
 To view our complete product line visit: www.woodfordmfg.com or email: sales@woodfordmfg.com
 A Division Of WCM Industries, Inc.