

# Installation Instructions

## Kitchen Faucet Filtration System –

GXK285JBL

### BEFORE YOU BEGIN

Read these instructions completely and carefully.

- **IMPORTANT** – Save these instructions for local inspector's use.
- **IMPORTANT** – Check with your local public works department for plumbing codes. You must follow their guides as you install the Water Filtration system.
- **Note to Installer** – Be sure to leave these instructions with the Consumer.
- **Note to Consumer** – Keep these instructions for future reference.
- **Skill level** – Installation of this appliance requires basic mechanical and electrical skills.
- **Completion time** – 60-90 minutes
- Proper installation is the responsibility of the installer.
- Product failure due to improper installation is not covered under the Warranty.

**⚠ WARNING** – Read "Important Safety Information" on page 2 before beginning installation.

### TOOLS AND MATERIALS REQUIRED FOR INSTALLATION

- Phillips screwdriver
- Two (2) adjustable wrenches
- Electric drill and drill bit to drill 1.25" hole (type as required) if mounting hole is needed for control valve
- Tape measure
- If your main water line is a rigid pipe, you will require a compression fitting and possibly other plumbing hardware to complete the installation (sold separately).

**NOTICE** – To avoid damaging the sink or countertop, consult a qualified plumber or installer for drilling procedures. Special drill bits may be needed for granite, stone, porcelain or stainless steel.

### CONTENTS INCLUDED WITH THE PRODUCT

- Water filter system assembly, including mounting screws
- Water line adapters and tubing
- Control Valve with LED Lights
- Decorative Knob and Nut
- Timer Box
- Batteries

### COLD WATER CONNECTION

A typical connection using the included water supply fitting is shown in the illustration below.

1. Close the water shut-off valve that is immediately in front of the supply tube and open the faucets to drain water from the sink cold water pipe.
2. Remove line that connects the cold water from faucet line to the supply valve. Some water may spill out.

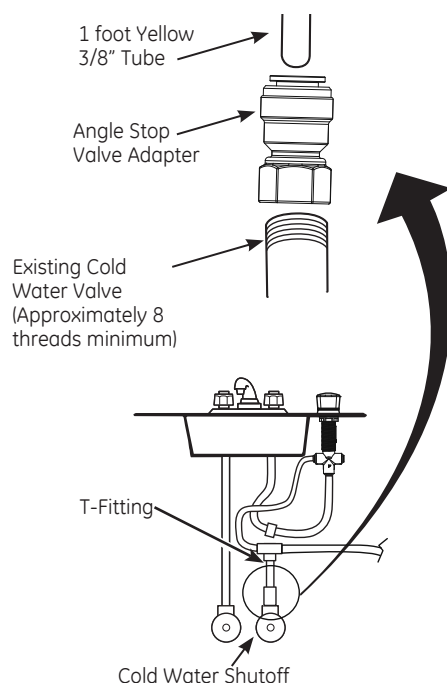

Fig. 1

3. Hand tighten the angle stop valve adapter onto the cold water valve. **NOTE: A minimum of approximately 8 threads is required on valve stem.** Finish tightening 1/2 turn with adjustable wrench. Be careful not to overtighten or cross-thread as damage to threads can occur. Some valve threads may be exposed when adapter is fully seated.
4. Insert one foot long yellow tube fully into angle stop valve adapter. Pull firmly on tube to make sure it is secure.
5. Insert one foot long yellow tube into bottom of T-fitting (see Figure 1). Insert 3 foot long yellow tube into one side of T-fitting. Insert 4 foot long yellow tube into other side of T-fitting. Pull firmly on tubes to make sure they are secure.

# Installation Instructions

6. Hand tighten the cold water line adapter into the cold water line from the faucet.  
Finish tightening with two adjustable wrenches. Be careful not to overtighten or cross thread as damage to threads can occur. Some threads may be exposed when adapter is fully seated.

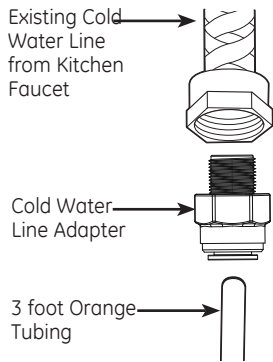

Fig. 2

7. Insert 3 foot orange tubing fully into cold water line adapter. Pull firmly on tube to make sure it is secure.

## INSTALL THE CONTROL VALVE

Be sure there is room underneath and above the sink to make the needed connections. Before starting, make sure there is sufficient room for the valve base. Select one of the following places to install the valve (1.25" diameter hole required):

- A. In an existing sink spray attachment or soap dispenser hole.
- B. In a hole to be drilled in the sink top.
- C. In a hole to be drilled in the countertop, next to the sink.

### NOTES:

- Be sure the valve base will fit flat against the surface at the selected location.

### Installation Steps (refer to illustration below for clarification)

1. If drilling is needed, make a 1.25" diameter hole. **Be sure to use the proper procedure for drilling granite, stone, porcelain or stainless steel. Special drill bits may be needed. Consult a qualified plumber for the proper procedure.**

## INSTALL THE CONTROL VALVE (continues)

**CAUTION:** When drilling in Stainless Steel, edges may be sharp and could damage wire. Be careful to not cut yourself or damage the wire.

2. To have filtered water dispensed from kitchen faucet when control valve is pointed toward faucet connect tubes as follows:

**NOTE: Refer to diagram on page 3 for tube routing.**

### IF CONTROL VALVE IS ON RIGHT SIDE OF FAUCET:

- Connect 4 foot long blue tube to port number "2".
- Connect 3 foot long yellow tube from T-fitting to port number "1".
- Connect 3 foot long orange tube to port "F" (bottom port)

Pull firmly on all tubes to make sure they are secure.

### IF CONTROL VALVE IS ON LEFT SIDE OF FAUCET:

- Connect 4 foot long blue tube to port number "1".
- Connect 3 foot long yellow tube from T-fitting to port number "2".
- Connect 3 foot long orange tube to port "F" (bottom port)

Pull firmly on all tubes to make sure they are secure.

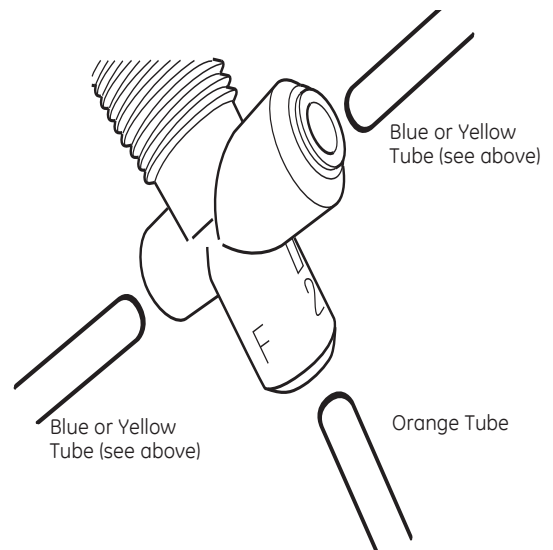

# Installation Instructions

## INSTALL THE CONTROL VALVE (continues)

3. With wire routed under rubber gasket and locking nut (as shown below) thread nut at least  $\frac{3}{4}$  toward bottom.

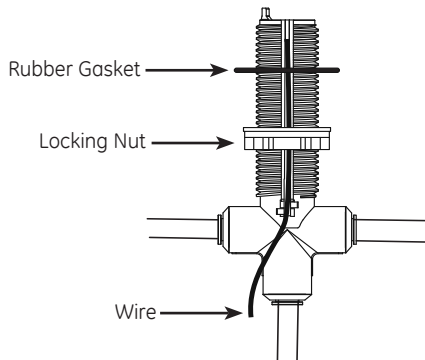

4. With "F" port label facing toward you (wire groove facing back of cabinet) insert control valve up through hole in sink/countertop.
5. Install 2nd rubber gasket on the control valve. Insert decorative nut on top of control valve turning fully until it stops, approximately two turns of nut. Do not overtighten.
6. Turn locking nut clockwise to tighten until it is firmly secure against underside of sink/ countertop. Do not allow control valve body to rotate, "F" port label should face toward you after locking nut is tight.

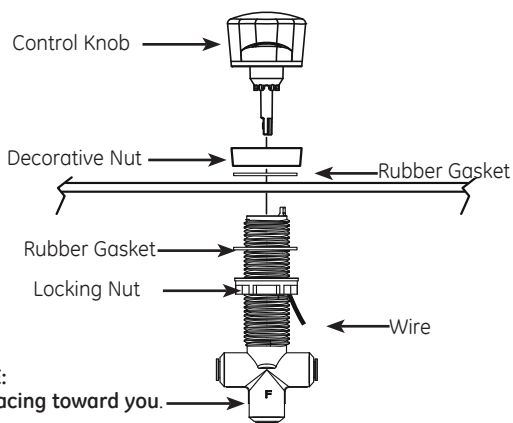

NOTE:  
"F" facing toward you.

## INSTALL THE CONTROL VALVE (continues)

7. Insert control knob into valve body.  
**NOTE: Knob only inserts in one position, rotate slowly until you feel it drop slightly into place. Then push down firmly to snap in place.**
8. Check knob rotation. Knob should rotate 180 degrees and point towards you as it rotates left/right. If point of knob rotates towards wall, then unit is installed backwards. Please review step 2.
9. Connect wire to timer box.
10. Find suitable location for timer box and battery access. Mount timer box to side of wall or cabinet with two screws (and drywall anchor) provided. **NOTE: Be careful not to pinch or screw through the wire.**
11. Install two AA, 1.5 volt, batteries into timer box.

# Installation Instructions

## MOUNTING SYSTEM INSTALLATION

Pick a location under the sink to mount the system. Location should be easily accessible, with 4" of clearance between the bottom of the filter canisters and the floor or bottom of the cabinet; any less will result in difficulty of removing filter canisters (see Fig. 5). Allow enough space on either side of the system for the tubing connections. System should be mounted at least 7" from front of cabinet to allow proper routing of tubing.

### SCREW INSTALLATION

1. Remove the top cover of system.
2. Screws should be placed a minimum of 15 inches above the bottom of the cabinet or floor where the system is to be mounted (Fig. 5).  
**NOTE: Any distance lower may result in filter canisters interfering with the floor when removed.**
3. Use the system as a template to mark screw hole locations where the screws are to be installed. Install screws into the wall, leaving 3/16 inch clearance between the head of the screw and wall (drill pilot holes if needed) (Fig. 6). Use anchors if mounting to drywall. Anchors require a 1/4" hole.
4. Hang system on screws and tighten until system is held firmly.
5. Install top cover onto system.
6. Install 4 foot long yellow tube into inlet (left side) of system (inlet and outlet are labeled on top of the system).
7. Install 4 foot long blue tube into outlet (right side) of system. Pull firmly on tubes to make sure they are secure.

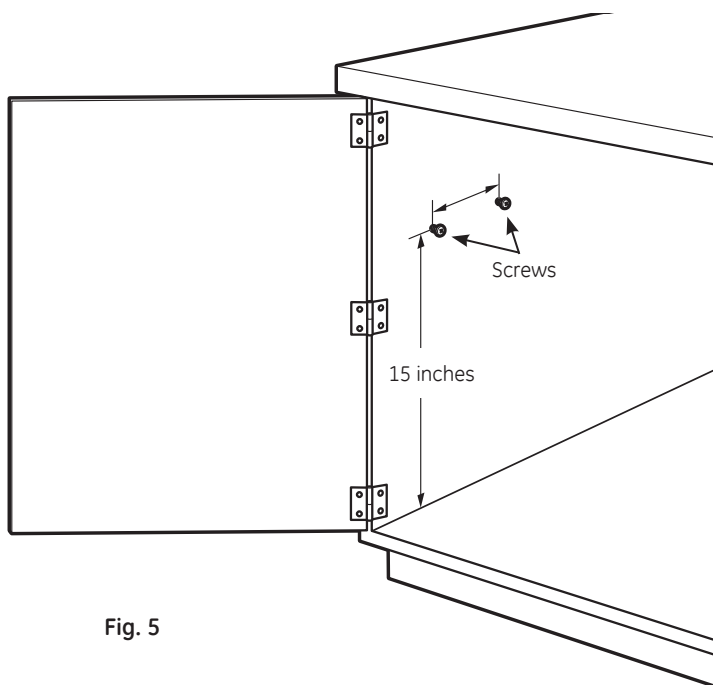
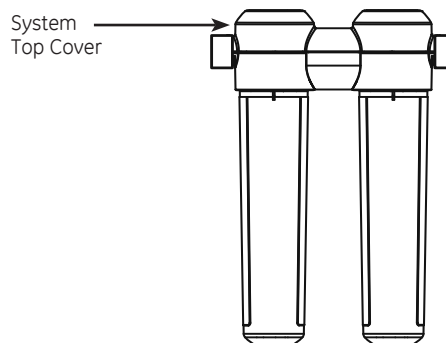
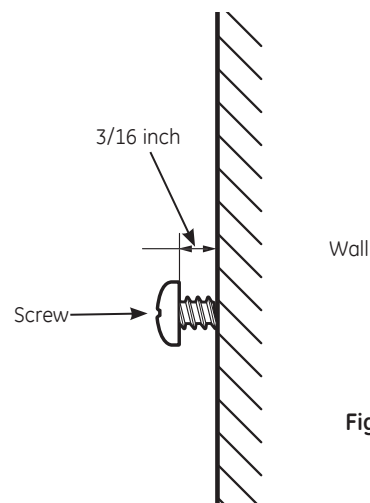

Fig. 5



Wall

Fig. 6

8. Remove shrink wrap from filters and install in system by turning approximately 1/3 turn until locked into place. Filter will raise up as it is turned. Filter label will be centered and facing forward when fully installed.  
**NOTE: System may exhibit low flow or no flow at all if the filter is not fully installed.**
9. Turn on water supply valve and check for leaks.
10. Perform Flush Procedure as described on page 8, steps 3-7.

# Installation Instructions

## FILTER CHANGE LIGHT

The clear ring at the bottom of the control knob will flash red to indicate it is time to change the filter and the battery.

The ring will double flash at six months to indicate it is time to replace the filter.

The ring will have a single fading flash at one year to indicate it is time to replace the filters and the batteries.

## INSTALLING OR REPLACING THE FILTER CANISTERS

**TO PROPERLY MAINTAIN SYSTEM AND REDUCE THE RISK OF PROPERTY DAMAGE DUE TO WATER LEAKAGE, CHANGING FILTER AS REQUIRED.**

*If installing the system for the first time skip to step 3.*

1. Remove the filter canisters from the manifold by rotating the canisters to the left about 1/3 turn.  
**NOTE:** A small amount of water from the tubing between the filter and the faucet may come out. A small towel should be able to catch it.
2. Remove shrink wrap on the new replacement filter canisters. Install the new canisters into the manifold by turning to the right about 1/3 turn until the filter stops. The filter will rise up as it is turned.

## FLUSH PROCEDURE

3. Turn on cold side of kitchen faucet. Turn control valve so it is pointing towards kitchen faucet (water will flow slower when passing through filters).

**NOTE: System may make noise during this procedure.**

4. Check for water leaks around the system.
5. Allow the system to run for 11 gallons (or 10 minutes) to flush out any harmless carbon fines that may be present.
6. Turn off faucet and check around system for leaks.
7. Reset timer by holding reset button on timer box for 5 seconds. Ring in base of control valve will light for 5 seconds. If single fading flash was occurring, replace batteries before resetting the timer.

## Replacement Filter Canisters/ Estimated Replacement Costs

FQK2J—Replacement filter canister \$45–55  
For replacement parts, call toll-free 800.626.2002 (U.S.) or 800.663.6060 (Canada–English).

## EMERGENCY REPLACEMENT PROCEDURE

Whenever water of unknown quality is passed through the GE Water Filtration system, the filter canisters should be discarded and the filtration system flushed.

**▲WARNING:** To reduce risk of ingestion of contaminants, do not use with water that is microbiologically unsafe or of unknown quality without adequate disinfection before or after the system.

**Circumstances that may require replacing the filters are:**

- Boil water advisory
- Flooding of the GE Water Filtration system
- Long-term non-use

**The procedure for flushing the GE Water Filtration system is:**

1. See *Replacing the Filter Canisters* section and follow steps 1–7.

# Parts List.

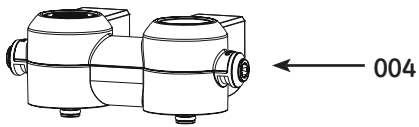

← 004

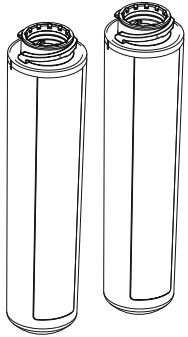

← 005

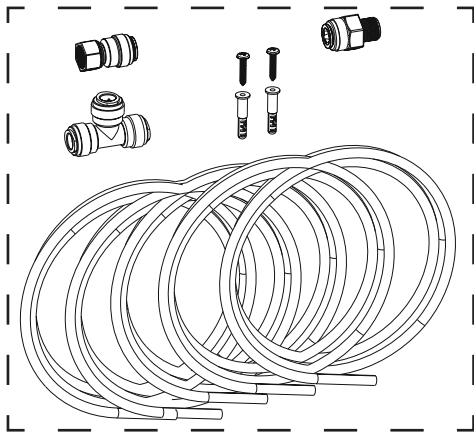

← 001

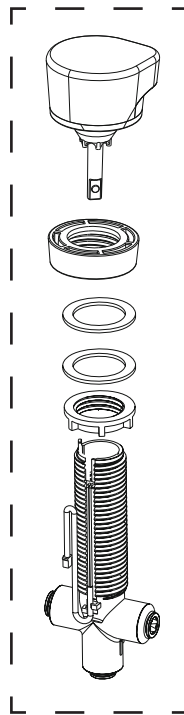

← 003

Ref. No.	Part No.	Part Description	
001	WS22X21084	Install Kit	1
002	WS15X21085	Timer	1
003	WS10X21083	Control Valve Assembly (Chrome)	1
004	WS19X21082	Filtration Manifold	1
005	FQK2J	Filter Set	1
999	49-50306	Owner's Manual	1

To obtain replacement parts, call toll-free 800.626.2002 (U.S.), 800.663.6060 (Canada-English).



← 999

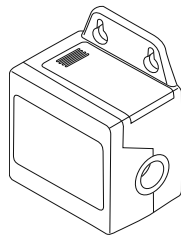

← 002