

**16757-CR7**



***Call Us First!***  
***DO NOT RETURN TO STORE.***

For immediate help with assembly or product information

call our toll-free number:

**1-800-221-1849**

or email:

***customerservice@backyardproductsllc.com***

**Our staff is ready to provide assistance.**

**April through October M - F 8:00 AM to 7:00 PM EST**

**Saturday 8:30 AM to 4:30 PM EST**

**November through March M - F 8:00 AM to 5:00 PM EST**

(This page intentionally left blank.)

# ASSEMBLY MANUAL

## MARCO SERIES

### PRINCETON 10' x 10' (305 x 305 cm)

ACTUAL FLOOR SIZE IS 120 x 116-5/8" (305 x 296 cm)

**KEEP THIS MANUAL FOR FUTURE REFERENCE**

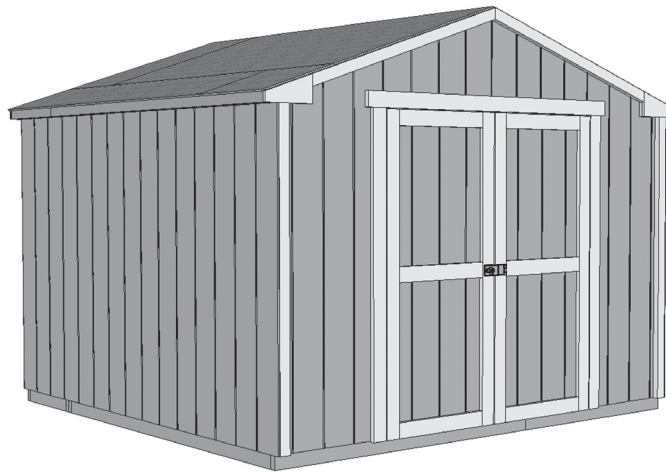

### **⚠ IMPORTANT! ⚠**

**READ INSTRUCTIONS THOROUGHLY PRIOR TO BEGINNING ASSEMBLY.**

### **BEFORE YOU BEGIN**

#### • BUILDING RESTRICTIONS AND APPROVALS

Be sure to check with local building department and homeowners association for specific restrictions and/ or requirements before building

#### • ENGINEERED DRAWINGS

Contact our Customer Service Team if engineered drawings are needed to pull local permits.

#### • SURFACE PREPARATION

To ensure proper assembly you must build your shed on a level surface. Recommended methods and materials to level your shed are listed on page 7.

#### • CHECK ALL PARTS

Inventory all parts listed on pages 4 - 5. Contact our Customer Service Team if any parts are missing or damaged.

#### • ADDITIONAL MATERIALS

You will need additional materials to complete your shed. See page 3 for required and optional materials and quantities.



**Call: 1-800-221-1849**

### **- CUSTOMER SERVICE -**

**email: [customerservice@backyardproductsllc.com](mailto:customerservice@backyardproductsllc.com)**



# TOOLS

## Required

Phillips Screwdriver 

Drill / Driver  
 3/8" Drill Bit  
 #2 Philips Drive Bit

Hammer 

Level 

Pencil 

Tape Measure 

Square  or 

Utility Knife   
 Shingle Blades 

Caulk Gun 

Paint Tools 

Safety Glasses 

Ladder 

## Optional

Tool Belt/ Nail Pouch 

Tin Snips (for drip edge) 

Chalk Line 

Nail Gun  
 gun nails 

Gloves 

Safety! Always use approved safety glasses during assembly.

## HELPFUL REMINDER SYMBOLS

Look for these symbols for helpful reminders throughout this manual.



= Assistance Required; two or more people.



= Ensure squareness.



= Important required step or operation.



= Helpful assembly hint.



= Mark part with pencil.



**BEGIN** = Beginning of steps for assembly or installation.



**FINISH** = You have finished the assembly or installation.



= Level

## ORIENT LUMBER AND TRIM FOR BEST APPEARANCE

Framing lumber is graded for structural strength and not appearance. Exterior trim is graded for one good side.

Always install the material leaving the best edge and best surface visible. Please remember that these blemishes in no way negatively affect the strength or integrity of our product. (See Fig. A, B, C.)

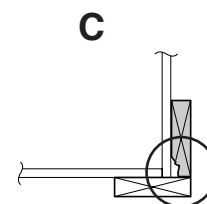
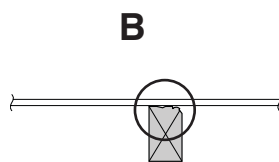
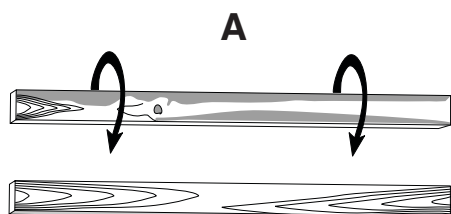

# ADDITIONAL MATERIALS

## FOUNDATION OR FLOOR MATERIALS

- This shed kit includes a complete wood floor frame system. It does not include any floor panels.
- See page 6 for the additional floor panel sizes and quantities required.
- This shed kit does not include ANY leveling materials.
- See the FLOOR LEVELING section on page 7 for recommended methods and suggested materials to properly level your floor, as this will vary depending on your specific site.

## REINFORCED WOOD FLOOR FRAME (OPTIONAL)

**IMPORTANT!** The included floor has been designed for general use. Depending on your specific use you may want to construct a heavy duty floor frame by adding additional floor joists (shown below as shaded). Below is a list of additional materials (not included):

- x1** 2 x 4 x 10' (5 x 10 x 305 cm) Treated Lumber  
Cut to (5) 2 x 4 x 21" (5 x 10 x 53,3 cm)
- x5** 2 x 4 x 8' (5 x 10 x 244 cm) Treated Lumber  
Cut to (5) 2 x 4 x 89-1/2" (5 x 10 x 227 cm)
- x40** ea. 3" (7,6 cm) Hot Dipped Galvanized Nails

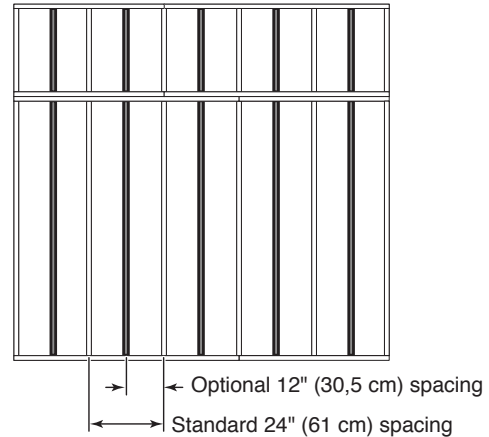

## COMPLETING YOUR SHED

You will need these additional materials:

- |  |   |
|--|---|
| <ul style="list-style-type: none"> <li><input type="checkbox"/> <b>3-TAB SHINGLES</b> ..... 5 Bundles</li> <li><input type="checkbox"/> <b>PAINT FOR SIDING</b> ..... 2 Gallons<br/>Use 100% acrylic latex exterior paint. (2) coats recommended.</li> <li><input type="checkbox"/> <b>CAULK</b> ..... 3 Tubes<br/>Use acrylic latex exterior caulk that is paintable. </li> <li><input type="checkbox"/> <b>x2 BOXES</b>  3" (7,6 cm)</li> <li><input type="checkbox"/> <b>x4 BOXES</b>  2" (5,0 cm)</li> </ul> | <ul style="list-style-type: none"> <li><input type="checkbox"/> <b>1" GALVANIZED ROOFING NAILS....</b> 2 Lbs<br/>For shingles.</li> <li><input type="checkbox"/> <b>PAINT FOR TRIM</b> .....1 Quart<br/>Use 100% acrylic latex exterior paint.</li> <li><input type="checkbox"/> <b>WOOD GLUE</b> ..... Exterior Rated</li> </ul> |
|--|---|

## OPTIONAL MATERIALS

- |   |   |
|---|---|
| <ul style="list-style-type: none"> <li><input type="checkbox"/> <b>DRIP EDGE</b> ..... 50 Feet</li> </ul> | <ul style="list-style-type: none"> <li><input type="checkbox"/> <b>#15 ROOFING FELT</b><br/>To cover 112 Sq. Ft. of roof area.</li> <li><input type="checkbox"/> <b>1" GALVANIZED ROOFING NAILS.....</b>1/4 Lb<br/>For roofing felt.</li> </ul> |
|---|---|

**REFER TO THE BACK OF THIS MANUAL AND THE MANUFACTURER'S INSTRUCTIONS FOR INSTALLATION OF SHINGLES, DRIP EDGE AND FELT.**

# PARTS IDENTIFICATION AND SIZES

Part identification is stamped on some parts.

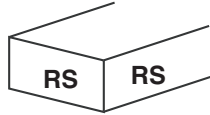

• Check these locations for part stamp.

Treated lumber is stamped:

**TREATED**

## WOOD SIZE CONVERSION CHART

Nominal Board Size	Actual Size
2" x 4".....	1-1/2" x 3-1/2" (3,8 x 8,9 cm)
1" x 4".....	3/4" x 3-1/2" (1,9 x 8,9 cm)
2" x 3".....	1-1/2" x 2-1/2" (3,8 x 6,3 cm)
1" x 3".....	3/4" x 2-1/2" (3,8 x 6,3 cm)





## PARTS LIST



**INVENTORY YOUR PARTS before you begin.**

**We suggest sorting parts by the category they are listed in.**







### FLOOR

- x6  2 x 4 x 21" (5 x 10 x 53 cm)
- x4  2 x 4 x 48" (5 x 10 x 122 cm)
- x4  2 x 4 x 72" (5 x 10 x 183 cm)
- x6  2 x 4 x 89-1/2" (5 x 10 x 227 cm)

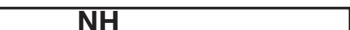

Treated lumber is stamped:

**TREATED**





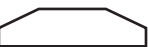



### WALL

- x1  2 x 3 x 22-1/8" (5 x 7,6 x 56 cm)
- x4  2 x 3 x 46-1/4" (5 x 7,6 x 117,5 cm)
- x8  2 x 3 x 69" (5 x 7,6 x 175,3)
- x2  2 x 3 x 70-1/4" (5 x 7,6 x 178,4)
- x4  2 x 3 x 72" (5 x 7,6 x 183 cm)
- x4  2 x 3 x 77" (5 x 7,6 x 196 cm)
- x2  2 x 3 x 94-1/2" (5 x 7,6 x 240 cm)
- x2  7/16 x 2-1/2 x 73-1/2" (1,1 x 6,3 x 187 cm)

### TRUSS



- x8  6 x 24" (15 x 61 cm)
- x8  2 x 4 x 65-7/8" (5 x 10 x 167 cm)

### TRIM

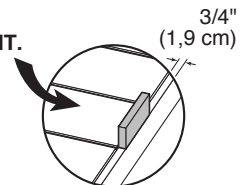
- x2  1 x 3 x 23-1/4" (2,5 x 7,6 x 59 cm)
- x4  2 x 3 x 58" (5 x 7,6 x 147,3 cm)
- x1  11/16 x 2-1/2 x 60-5/8" (1,7 x 6,3 x 154 cm)
- x2  1 x 3 x 95-1/2" (2,5 x 7,6 x 242,5 cm)
- x2  19/32 x 2-1/2 x 26-5/8" (1,5 x 6,3 x 67,6 cm)
- x1  1 x 3 x 5" (2,5 x 7,6 x 12,7 cm) **USED AS A GAUGE BLOCK FOR 3/4" (1,9 CM) MEASUREMENT.**
- x4  1 x 3 x 7-1/2" (2,5 x 7,6 x 19 cm)
- x4  3/4 x 5-1/8 x 8-3/8" (1,9 x 13 x 21,3 cm) **RIGHT PAINTED RED  
LEFT PAINTED GREEN**



### DOOR

- x2  1-1/4 x 2-1/2 x 69" (3,2 x 7,6 x 175,3 cm)
- x1  5/8 x 3 x 72" (1,6 x 6,3 x 183 cm)

## WALL PANEL & DOORS PARTS LIST

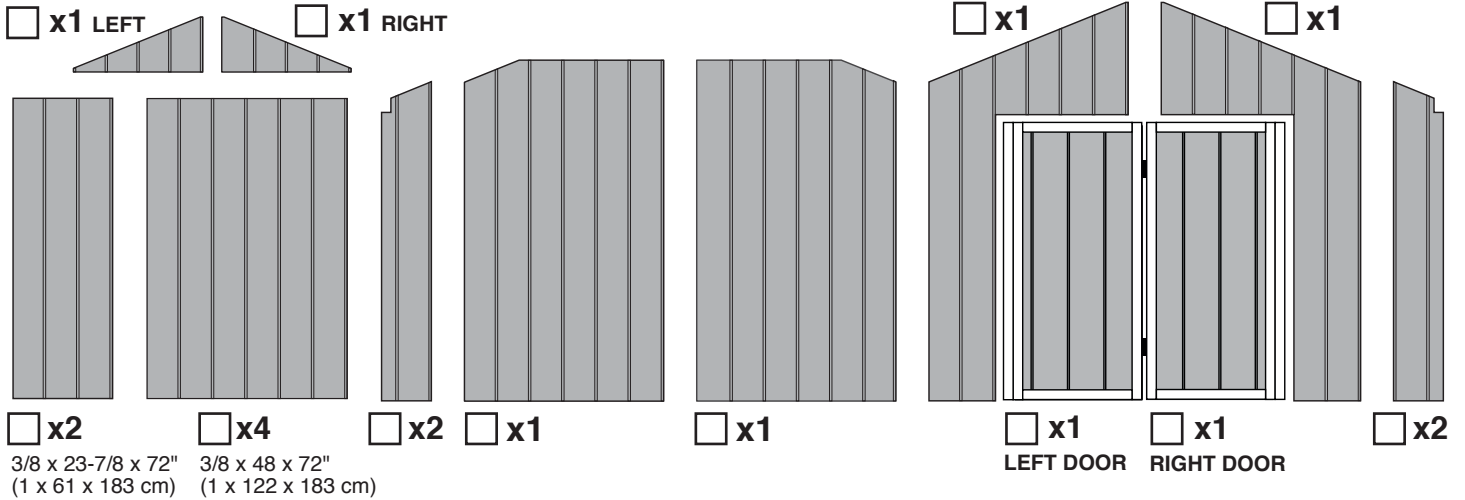

## ROOF PANELS

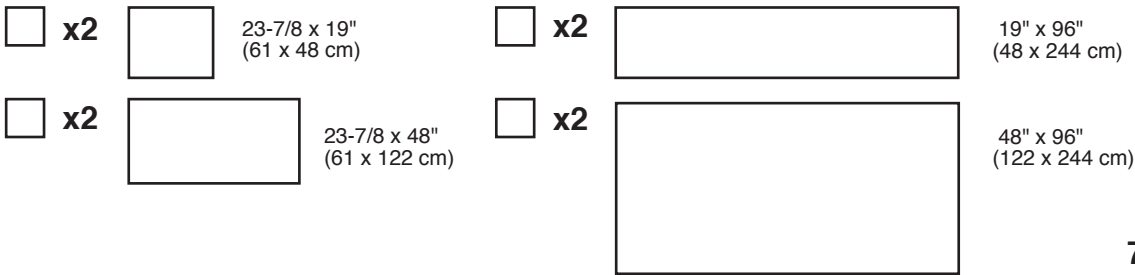

Roof panels are 7/16" (1,1 cm) thick.

## SOFFIT PANELS

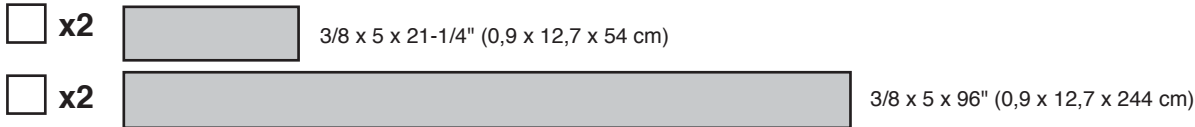

## NAIL BOXES (Shown Actual Size)

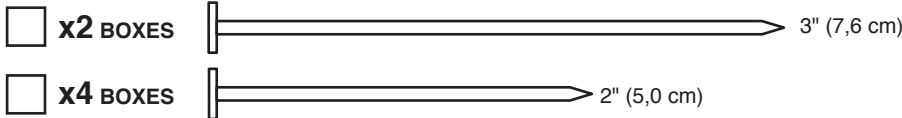

## FASTENER/HARDWARE BAG (Shown Actual Size)

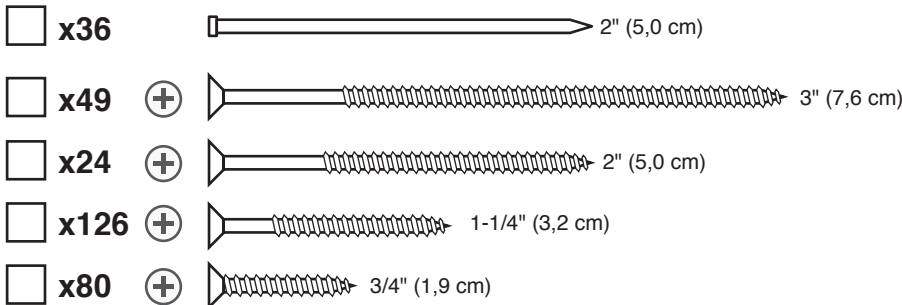

## DOOR HARDWARE (Not Actual Size)



## **FLOOR PANELS (Not Included)**

You will need floor panels and nails to complete your floor. -Floor panel sizes and quantities are shown below.

NOTE: Use a minimum of 5/8" (1,6 cm) oriented strand board (OSB).

**x1**  23-7/8 x 23-7/8" (61 x 61 cm)

**x1**  23-7/8 x 92-5/8" (61 x 235,3 cm)

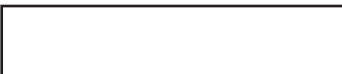
**x1**  23-7/8 x 96" (61 x 244 cm)

**x2**  48 x 92-5/8" (122 x 235,3 cm)

**x1** 1 lb. of 2" (5,0 cm) Hot Dipped Galvanized Box-Type Nails

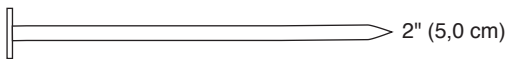

## **NOTES**

---

---

---

---

---

---

---

---

---

---

---



## FLOOR LEVELING OPTIONS

There are multiple ways to level your floor frame. Our recommended leveling method is shown below.  
**Leveling materials are not included in this kit.**

### PREFERRED METHOD - 4x4 TREATED RUNNERS

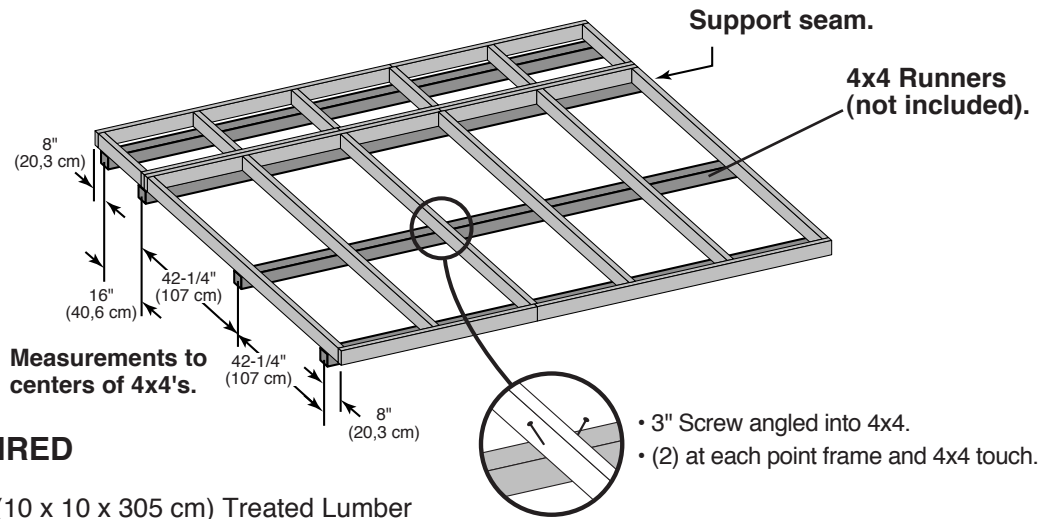

#### MATERIAL REQUIRED

**x4** 4" x 4" x 10' (10 x 10 x 305 cm) Treated Lumber

**Fasteners for Frame to 4"x 4"**.  
 (3" Screws shown as one option.) Minimum (48) 3" screws / exterior grade.

**!** Use only wood treated for ground contact and fasteners approved for use with treated wood.

**!** Always support frame seams.

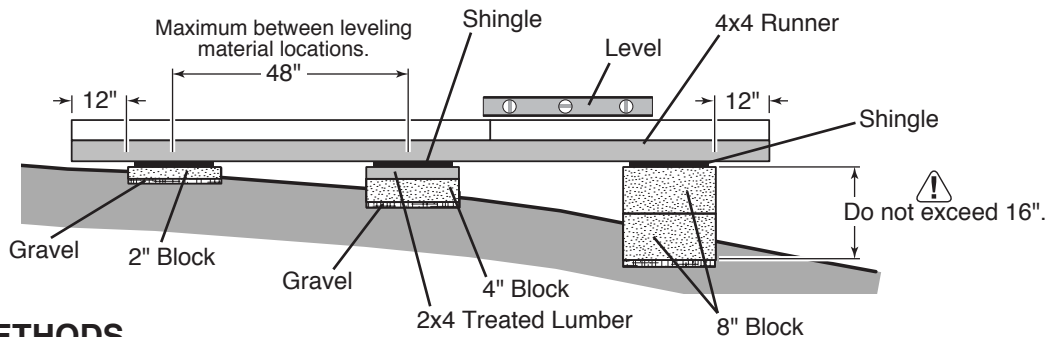

#### LEVELING METHODS

- Level under 4x4 runners only.
- Locate leveling material 12" from ends of runners and no more than 48" apart.
- Asphalt shingles should be used between 4x4 runners and blocks or treated lumber. Never use shingles in direct contact with ground.
- For best results and aiding in water drainage use gravel under each concrete block.

#### LEVELING MATERIALS

- Gravel
- Solid Masonry Blocks in 1", 2", 4" or 8" thickness
- 2x4 Treated Lumber
- Asphalt Shingles

**!** Leveling higher than 16" not recommended.

#### CONCRETE

- If you are building your shed on a concrete foundation see the following page.

## CONCRETE FOUNDATION

Your kit contains all materials to construct a wooden floor. If you choose to install your kit on a concrete slab refer to the diagram below.

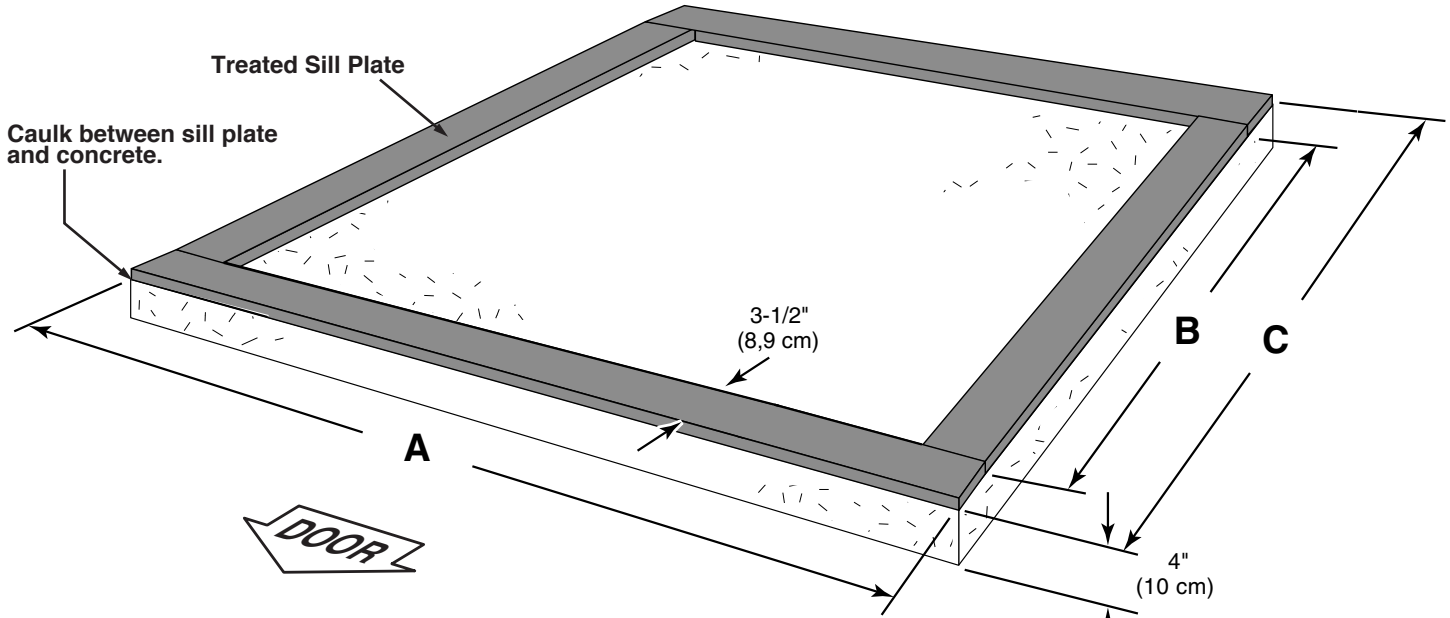

Building Size	Actual Floor Size	A	B	C
10'x 10' (305 x 305 cm)	10'x 9'-8-5/8" (305 x 296 cm)	120" (305 cm)	109-5/8" (278 cm)	116-5/8" (296 cm)

**Requires:**

- x4** 2 x 4 x 10' (5 x 10 x 305 cm) **MUST be treated lumber.**
- x1** **Caulk**

Allow new concrete slabs to cure for at least seven (7) days.

- A treated 2 x 4" (5 x 10 cm) sill plate is required when installing your shed on concrete. **Hint: Use treated lumber in your kit or purchase full length treated lumber.**
- Use a high quality exterior grade caulk beneath all sill plates.
- Fasten 2 x 4" (5 x 10 cm) sill plates to slab using approved concrete anchors (**fasteners not included**).
- Check local code for concrete foundation requirements.

## NOTES

---

---

---

---

---

---

---

---

---

---

# FLOOR FRAME

## PARTS REQUIRED:

x2 **TREATED**  
2 x 4 x 72" (5 x 10 x 183 cm)

x2 **TREATED**  
2 x 4 x 48" (5 x 10 x 122 cm)

x6 **TREATED**  
2 x 4 x 21" (5 x 10 x 53 cm)

**NOTE:**  
Look for **TREATED** Stamp.

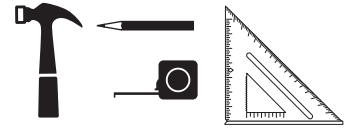
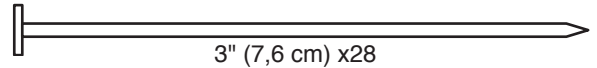

✓ **BEGIN** ⚠ You will build two floor sections.

- 1 Orient parts as shown on flat surface. Measure and mark each dimension from end of boards.
- 2 Use two 3" nails at each mark.

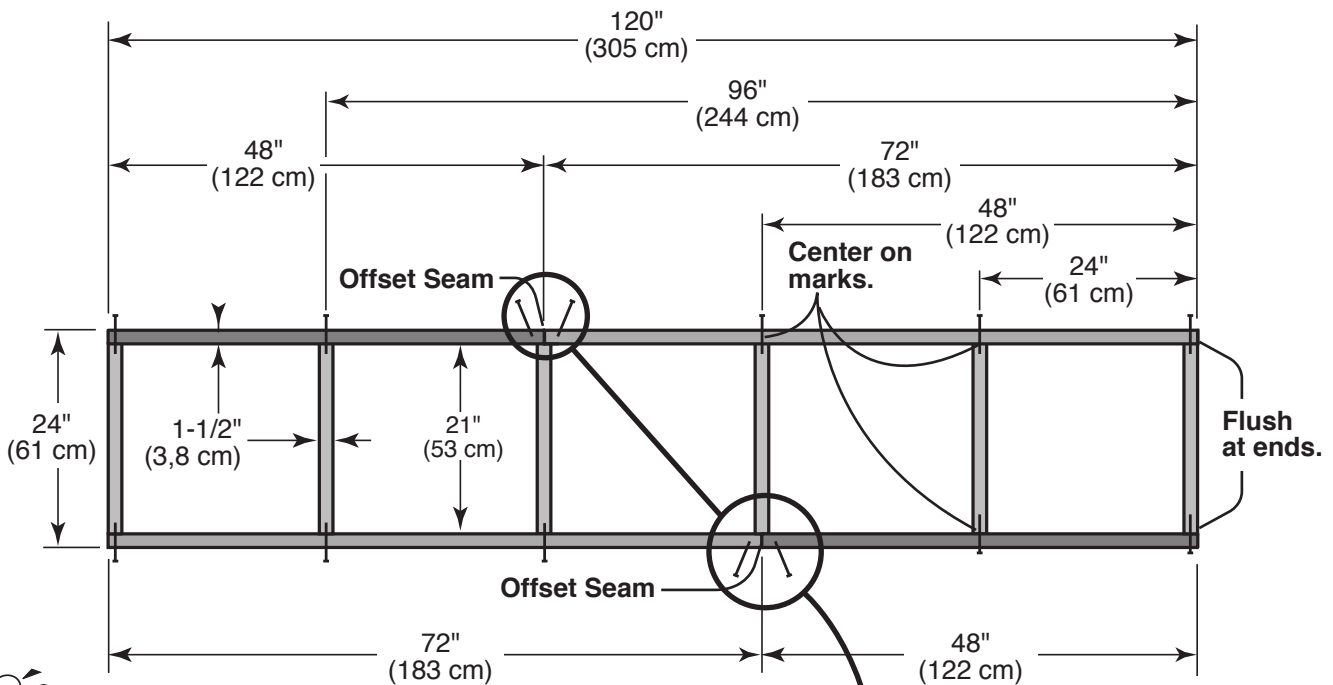
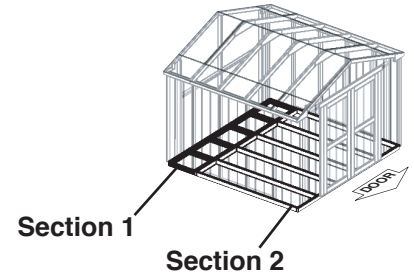

**HINT:**  
For easier nailing  
stand on frame.

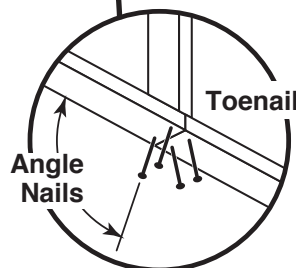
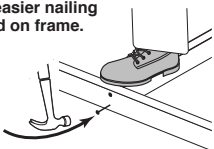

# FLOOR FRAME

## PARTS REQUIRED:

**x2** TREATED  
2 x 4 x 72" (5 x 10 x 183 cm) Treated Wood

**x6** TREATED  
2 x 4 x 89-1/2" (5 x 10 x 227 cm) Treated Wood

**x2** TREATED  
2 x 4 x 48" (5 x 10 x 122 cm) Treated Wood

**NOTE:** Look for TREATED Stamp.

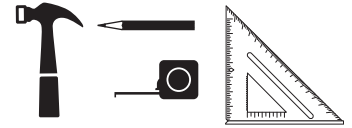
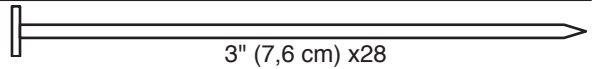

**3** Orient parts as shown on flat surface. Measure and mark from end of boards.

**4** Use two 3" nails at each mark.

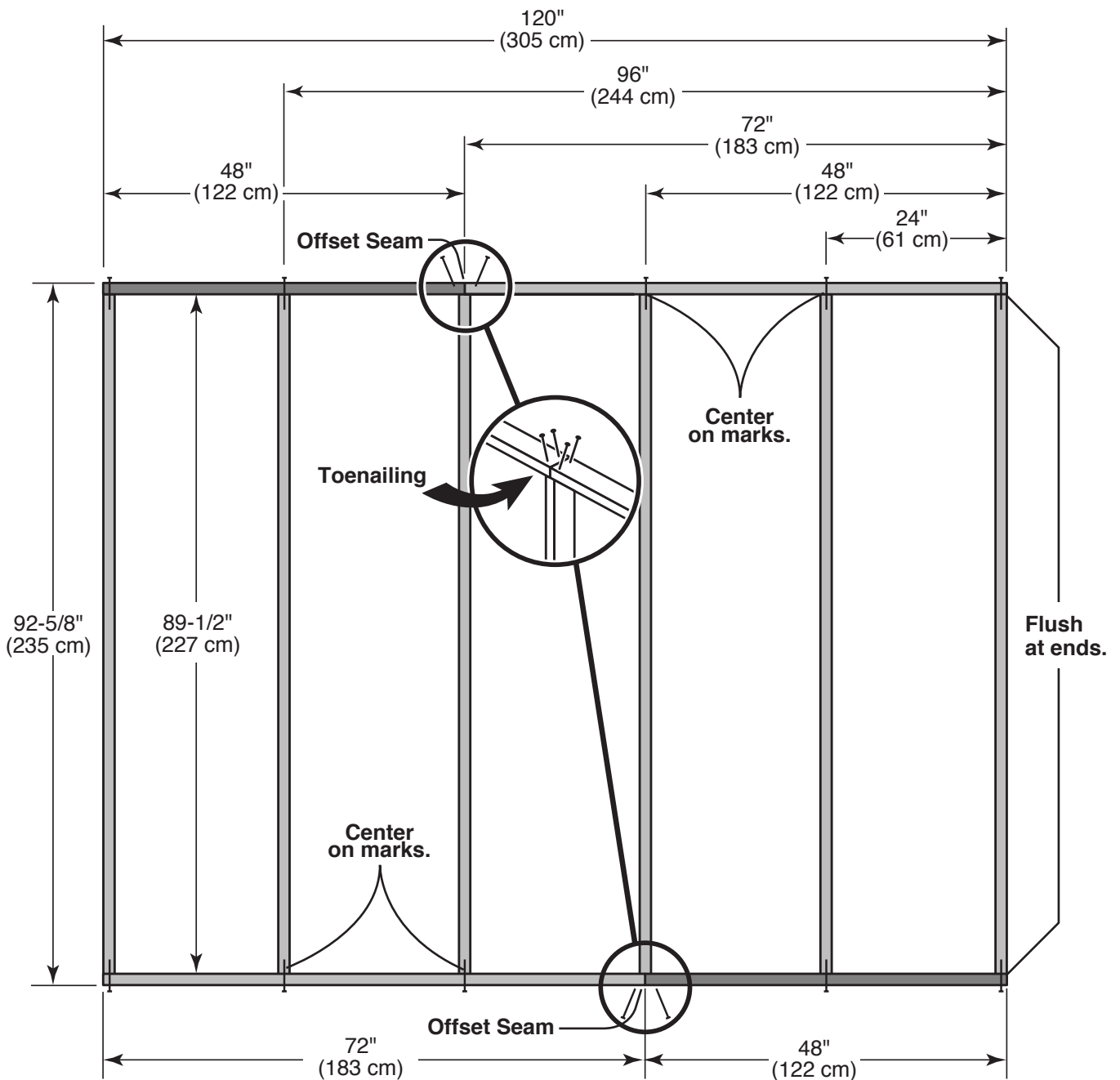
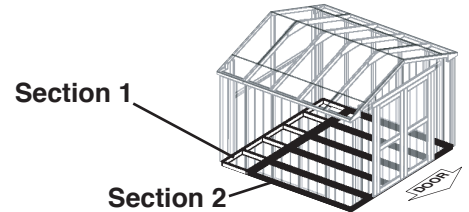

# FLOOR FRAME

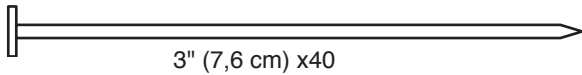

**5** Put both floor sections together and attach as shown using 3" nails.



**6** You have finished your floor frame. Proceed to level and square frame.

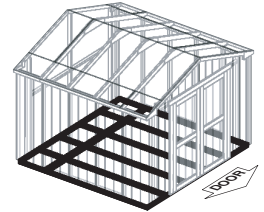

(4) Nails per side, stagger pattern.

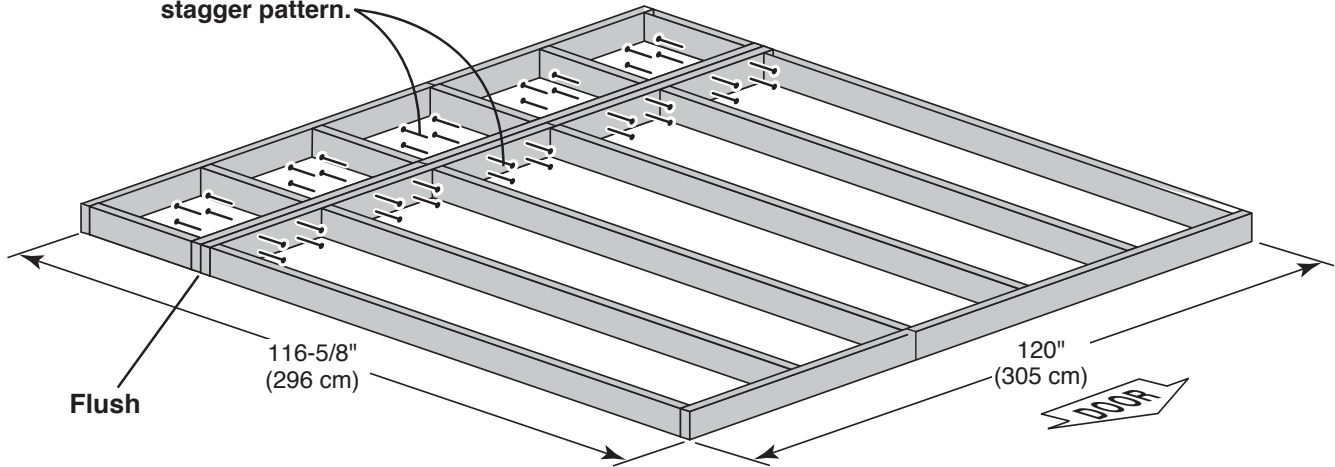

**STOP!**



## LEVEL AND SQUARE FLOOR FRAME



Before attaching floor decking, it is important to level and square the floor frame. A level and square floor frame is required to correctly construct your shed.

**STOP!**

**BEGIN**

- 1** ⚠ See page 7 for the preferred floor leveling method.
- 2** Use level and check the frame is level before applying floor panels.
- 3** Check for frame squareness by measuring diagonally across corners. If the measurements are the same, the frame is square. The diagonal measurement will be approximately 167-3/8" (425 cm).
- 4** When the frame is level and square secure one side of frame to the 4x4 runners using one fastener at ends of each runner. At the opposite end of the frame, secure the frame to 4x4 runners with one fastener at ends of each runner making sure the frame remains square (**Fig. A**).



**5** Once the floor frame is level and square fasten the frame at each point the frame contacts the 4x4 runners.

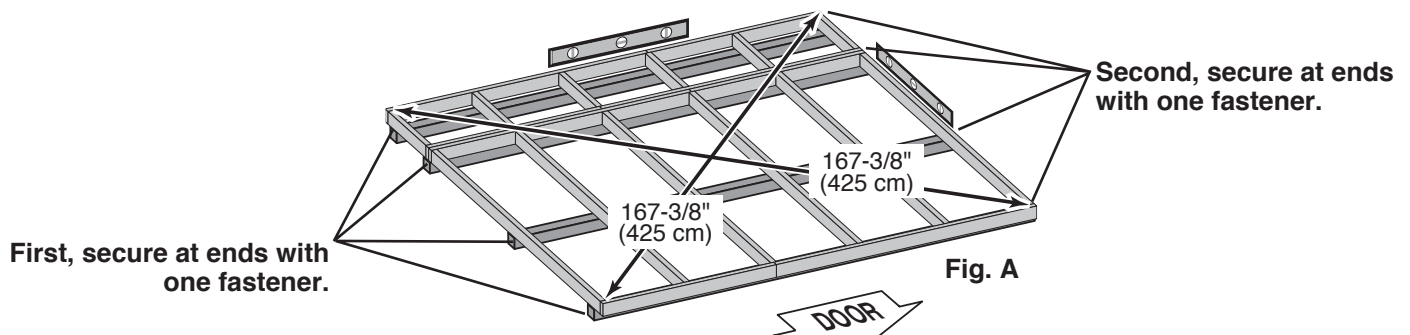

# FLOOR PANELS

## PARTS REQUIRED:

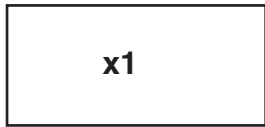

5/8 x 48 x 92-5/8"  
(1,6 x 122 x 235 cm)



**FLOOR PANELS NOT INCLUDED.  
SEE PAGE 6 FOR PANEL SIZES  
AND QUANTITIES.**

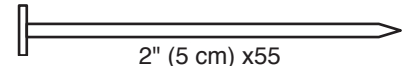

**Ensure your floor frame is square by installing one panel and squaring frame.**

✓ **BEGIN**

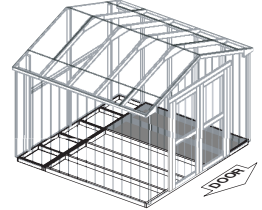

- 1** Attach the 48 x 92-5/8" panel with the rough side up (painted-grid lines side) with the 48" edge and corner flush to the floor frame (**Fig A**). Secure panel with two 2" nails in the corners.
- 2** Move to the opposite end. Using the long edge of the panel as a lever move the panel side-to-side until the top corner is flush to the floor frame (**Fig. B**). Secure panel with two 2" nails in the corners.
- 3** Check the floor frame is square by measuring diagonally across the frame corners. If the measurements are the same your floor frame is square. The measurement will be approximately 167-3/8" (425 cm) (**Fig. C**).
- 4** Continue attaching the panel using 2" nails 6" apart on edges and 12" apart inside panel. Use a chalk line or use pre-painted grid lines to nail into joists under panel.

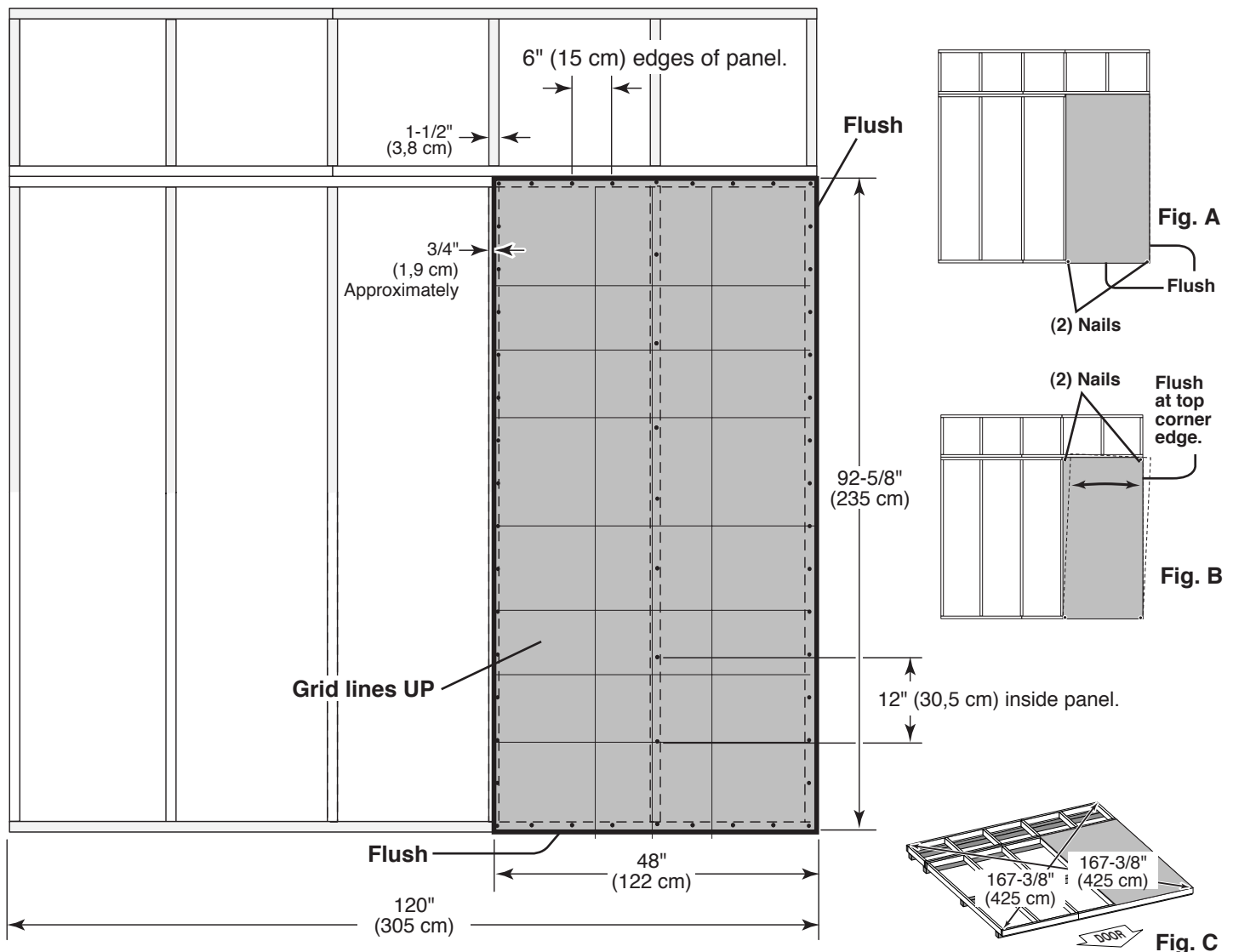

# FLOOR PANELS

## PARTS REQUIRED:

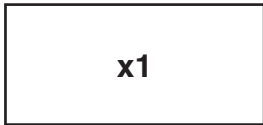

x1

5/8 x 48 x 92-5/8"  
(1,6 x 122 x 235 cm)

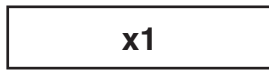

x1

5/8 x 23-7/8 x 92-5/8"  
(1,6 x 61 x 235 cm)

x1 5/8 x 23-7/8 x 23-7/8"  
(1,6 x 61 x 61 cm)

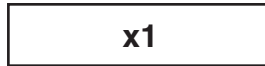

x1

5/8 x 23-7/8 x 96"  
(1,6 x 61 x 244 cm)

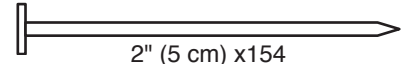

2" (5 cm) x154



**5** Continue installing panels with rough side up (painted grid lines).

**6** Use a chalk line or grid lines on panels for 2" nails 6" apart on edges and 12" apart inside panel.



FINISH

**7** You have finished Installing your floor panels.

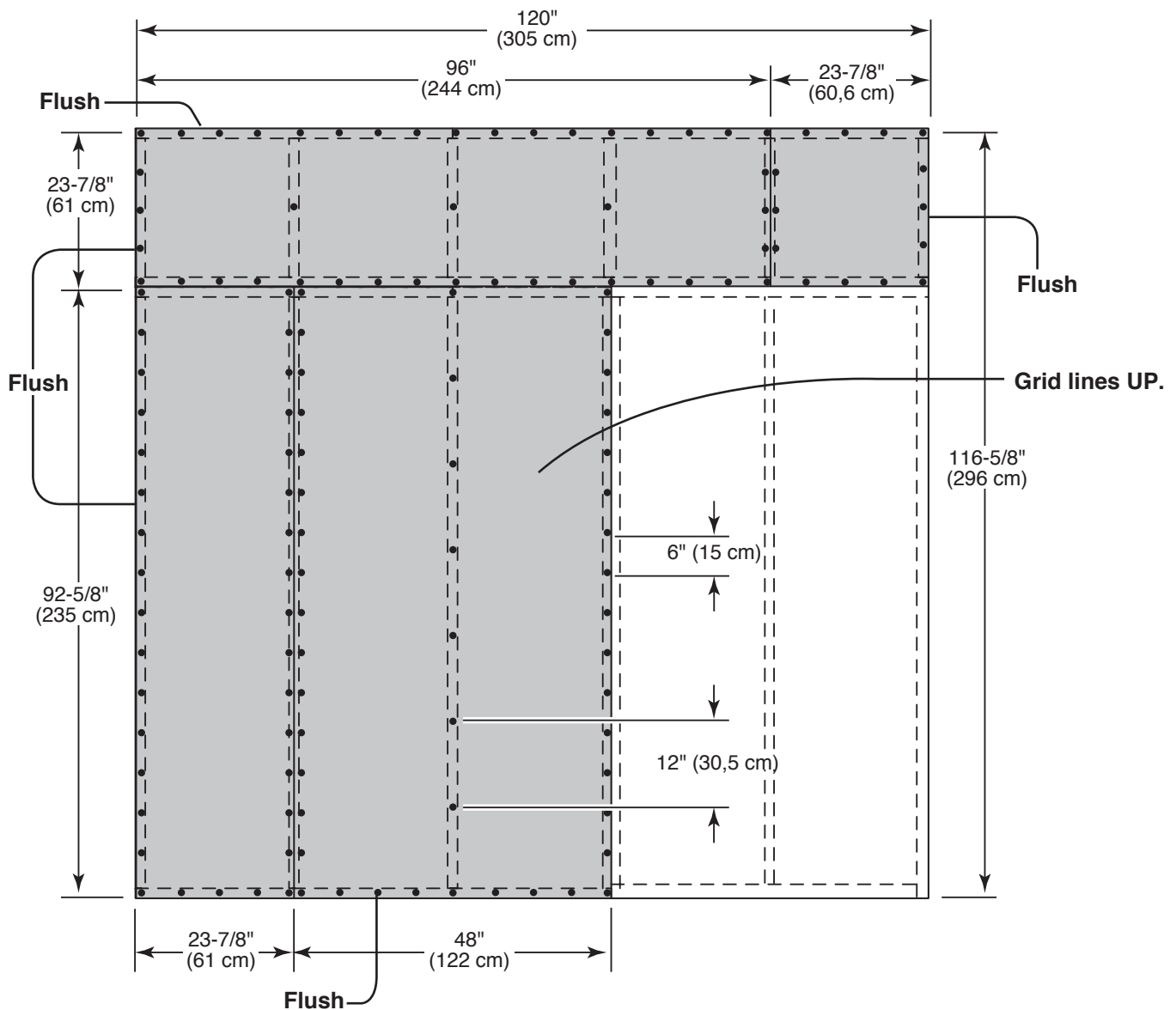
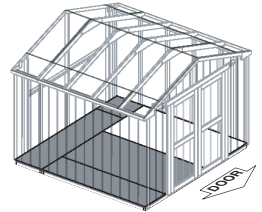

**! IMPORTANT!**



**STOP!** Check the floor frame is level after installing floor panels. Re-level if needed.

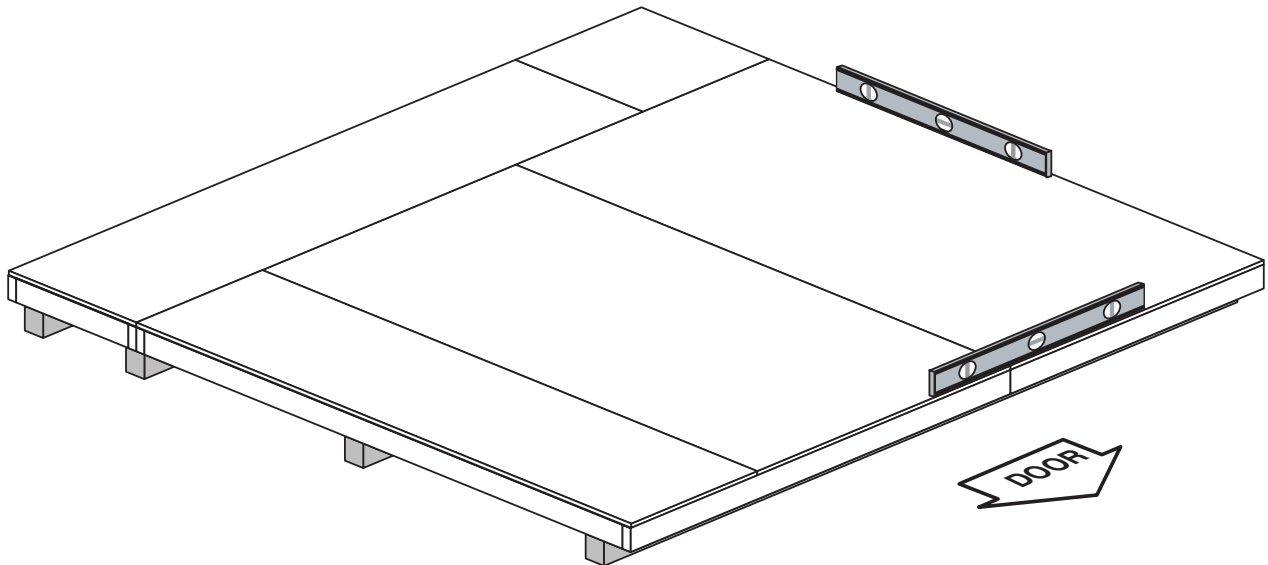

• The floor should be used as a stable work surface for wall construction.

**HINT:** • Organize your assembly procedure during the build process to avoid over-handling of the walls.

**BACKWALL**

**SIDEWALL**

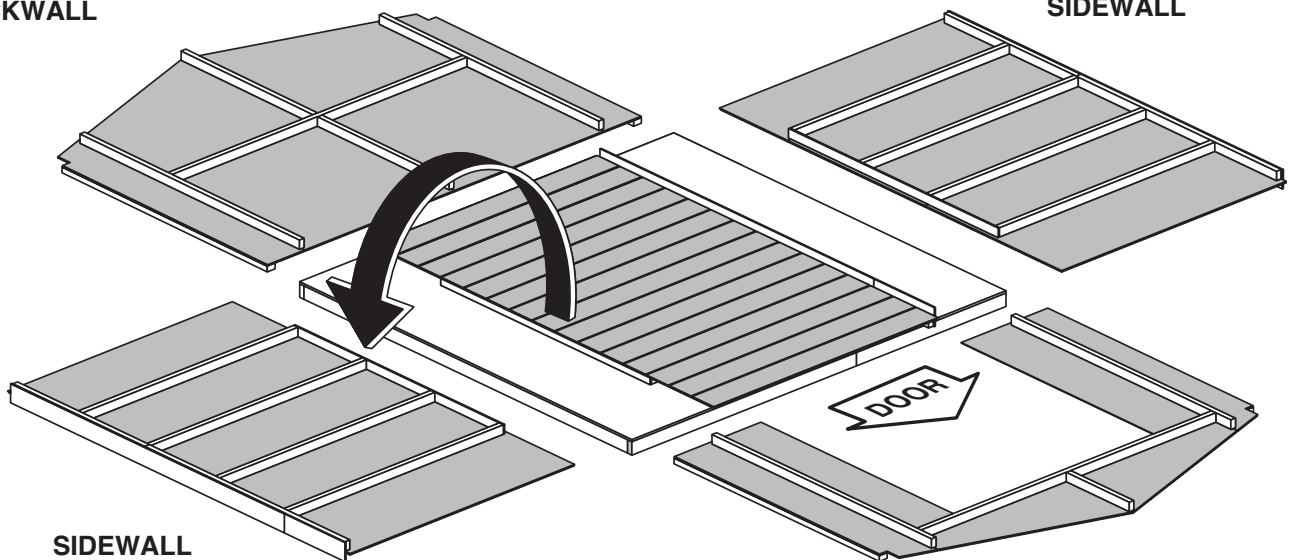

**SIDEWALL**

**FRONTWALL**



# RAFTER ASSEMBLY JIG

## PARTS REQUIRED:

x4 **GBB** 1 x 3 x 7-1/2" (2,5 x 7,6 x 19 cm)

1-1/4" (3,2 cm) x8

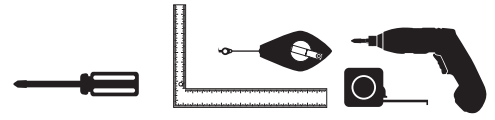

✓ **BEGIN**

- 1 Build a **Jig** to ensure all **Rafters** are assembled the same.
- 2 Mark a straight line on the **Floor** from corner to corner.
- 3 Screw blocks in place to measurement shown.

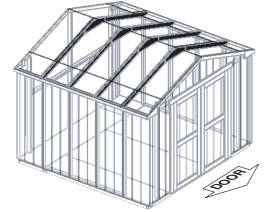

FINISH

⚠ **Make sure blocks are square and at 125" (317,5 cm)**

- 4 You have finished building a **Rafter Jig**.

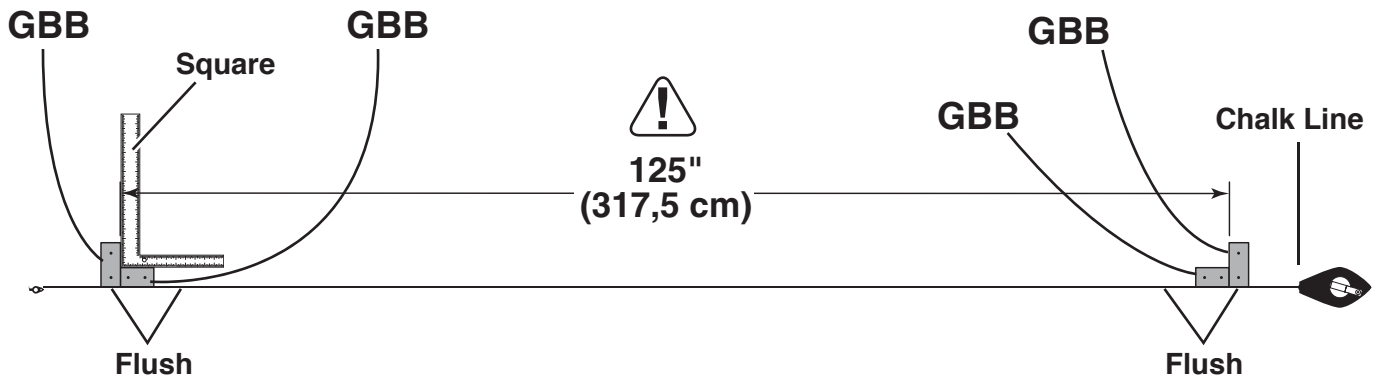
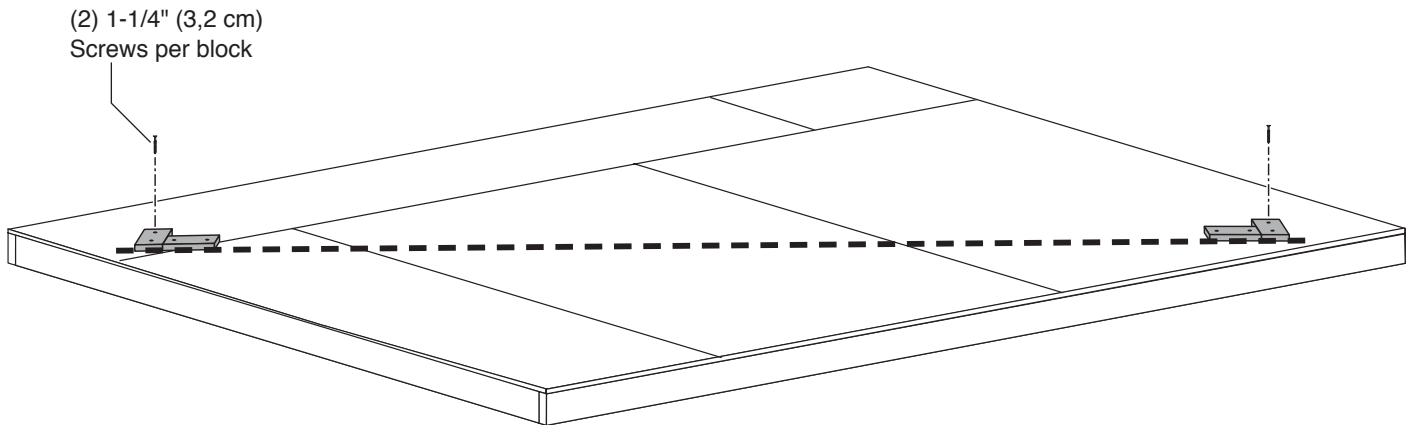

# RAFTERS

## PARTS REQUIRED:

x8  6 x 24" (15 x 61 cm)

x8 **CV**   
2 x 4 x 65-7/8" (5 x 10 x 167 cm)

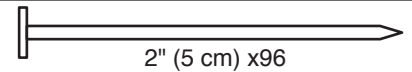

### ✓ BEGIN

- 1 Place two rafter halves **CV** on floor jig. You will assemble (4) rafters.
- 2  **Rafters should touch at peak.** Apply glue on gusset and place on rafters.
- 3 Nail gusset onto rafter using 2" nails, staggered, as shown.
- 4 Flip over rafter assembly and glue and nail gusset to back side.
- 5 Repeat steps 1-4 to build three more assemblies.

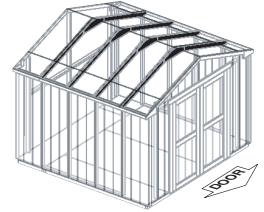

### FINISH

- 6 Unscrew jig and save blocks. Set aside rafters and proceed to building your back wall.

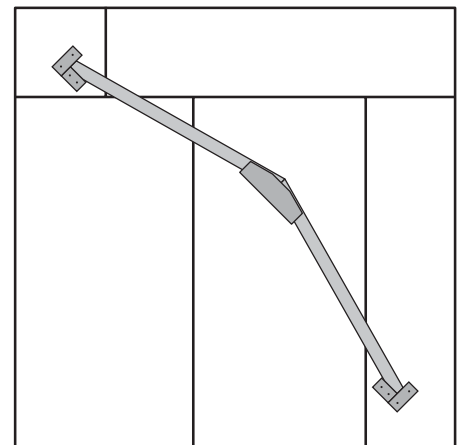
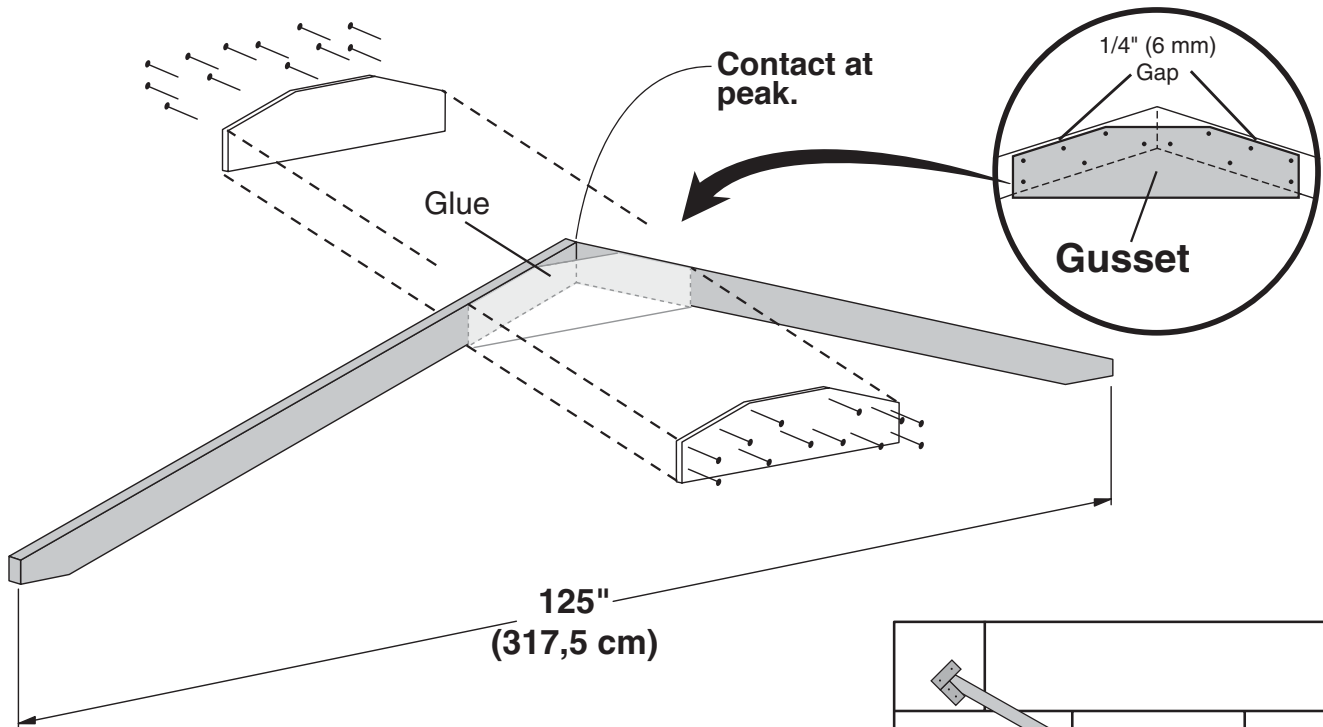

Use Jig to assemble Rafters.

# BACK WALL FRAME

## PARTS REQUIRED:

- x1 **NH**  
2 x 3 x 46-1/4" (5 x 7,6 x 117,5 cm)
- x2 **PB**  
2 x 3 x 77" (5 x 7,6 x 196 cm)
- x1 **PR**  
2 x 3 x 94-1/2" (5 x 7,6 x 240 cm)

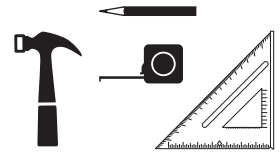
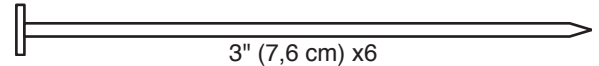

### ✓ BEGIN

- 1 Orient parts on edge on floor as shown.
- 2 Nail using two 3" nails at each connection.

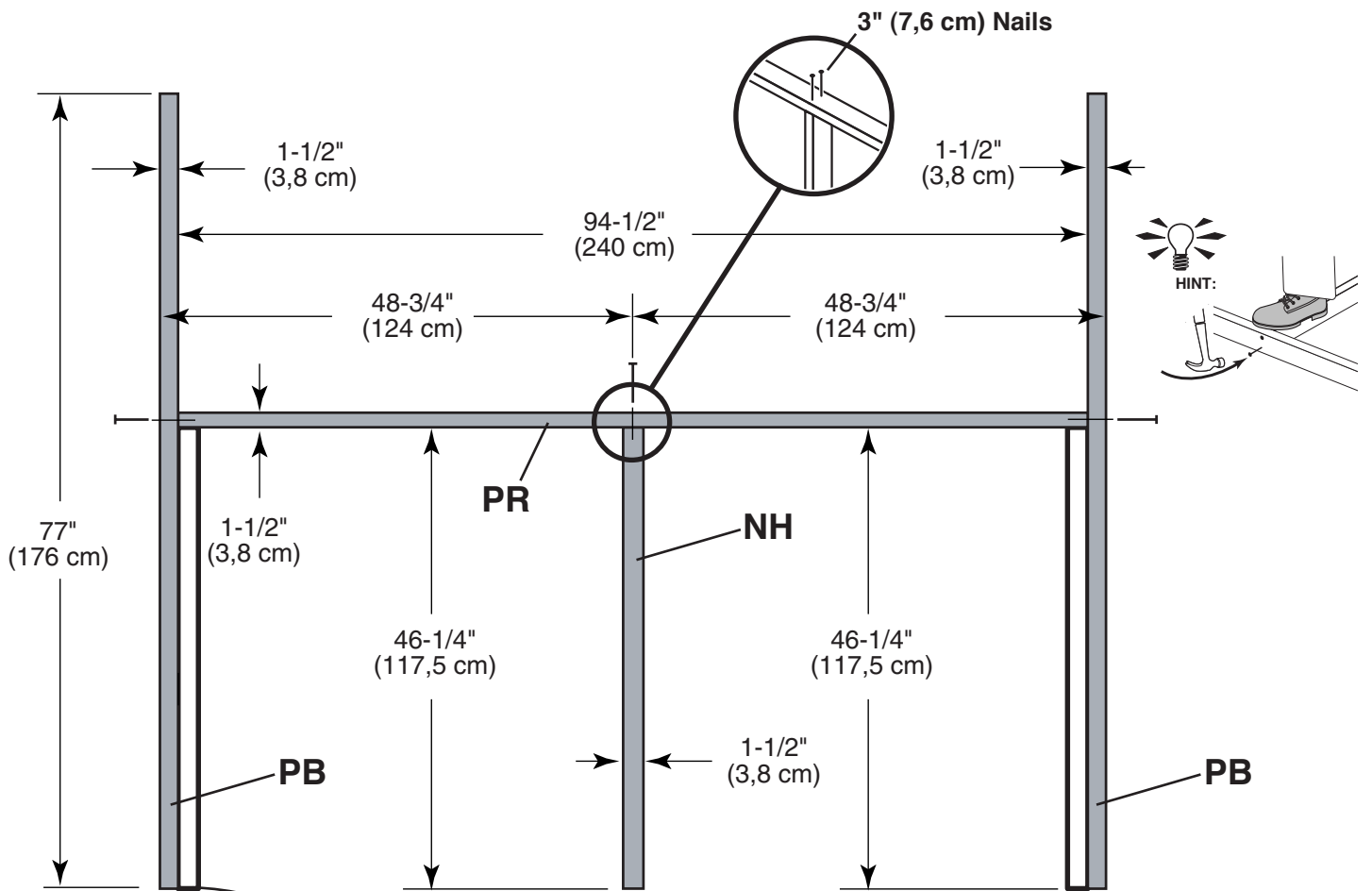
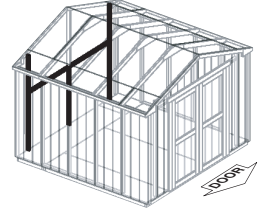

Use NH as a guide to locate PB. (Do not nail.)

## BACK WALL FRAME

### PARTS REQUIRED:

x1 **NH**  
2 x 3 x 46-1/4" (5 x 7,6 x 117,5 cm)

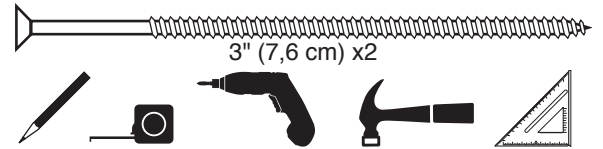

- 3 Orient parts on edge on floor as shown.
- 4 Use two 3" screws at middle connection.



FINISH

- 5 You have finished building your back wall frame.

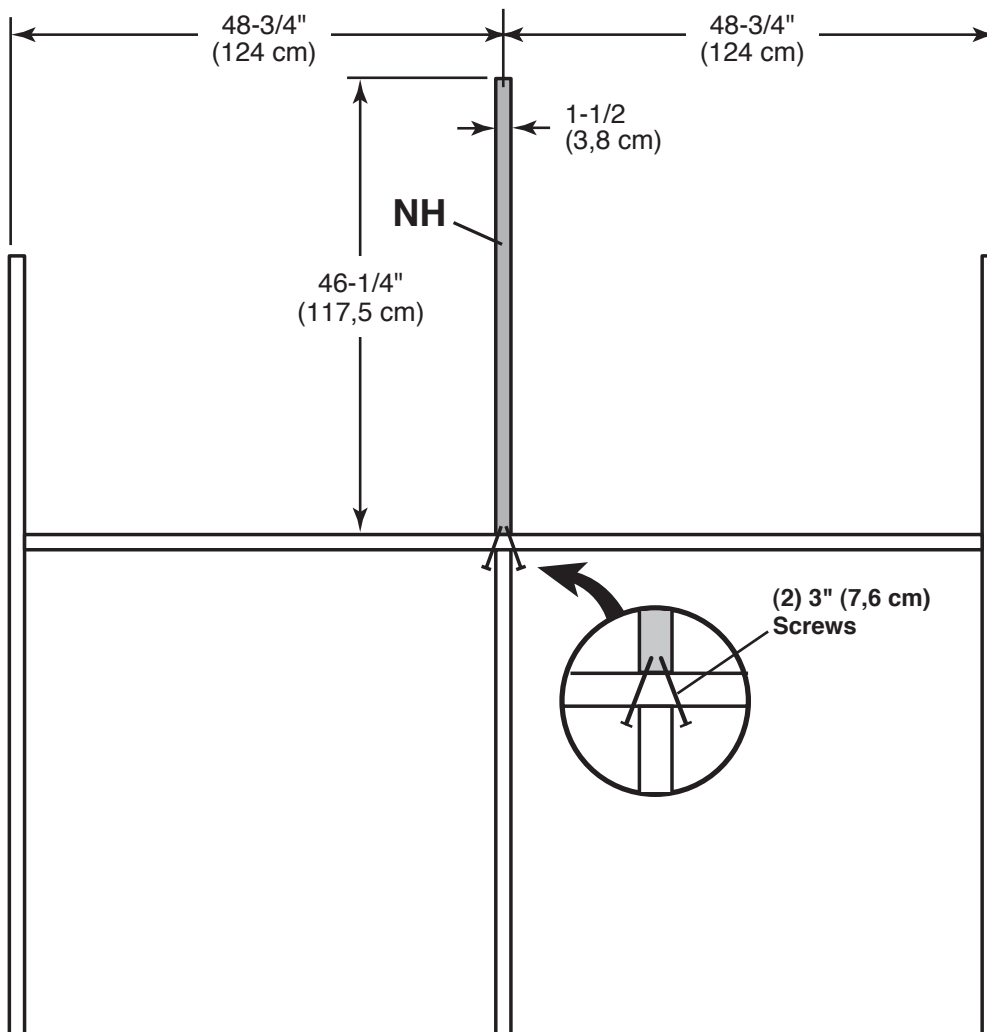
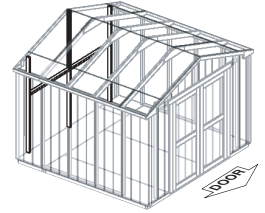

# BACK WALL PANELS

## PARTS REQUIRED:

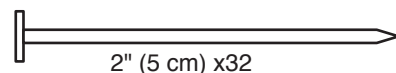
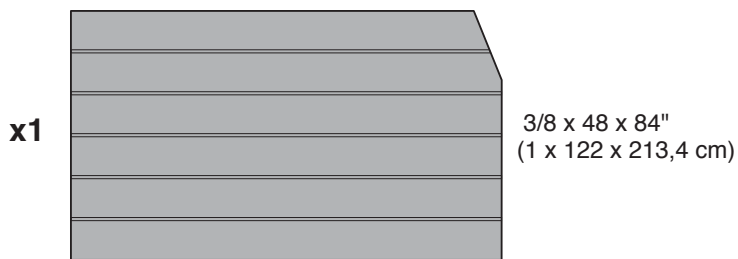

### ✓ BEGIN

- 1 Place **LEFT** panel on back frame as shown with primed side facing up.
- 2 Use a 3/4" gauge block at edges of panel. **!** Be sure to maintain 1" measurement between bottom edge of frame and bottom edge of panel (**Fig. A, B**).
- 3 Nail using 2" nails 6" apart on edges and 12" apart inside panel.

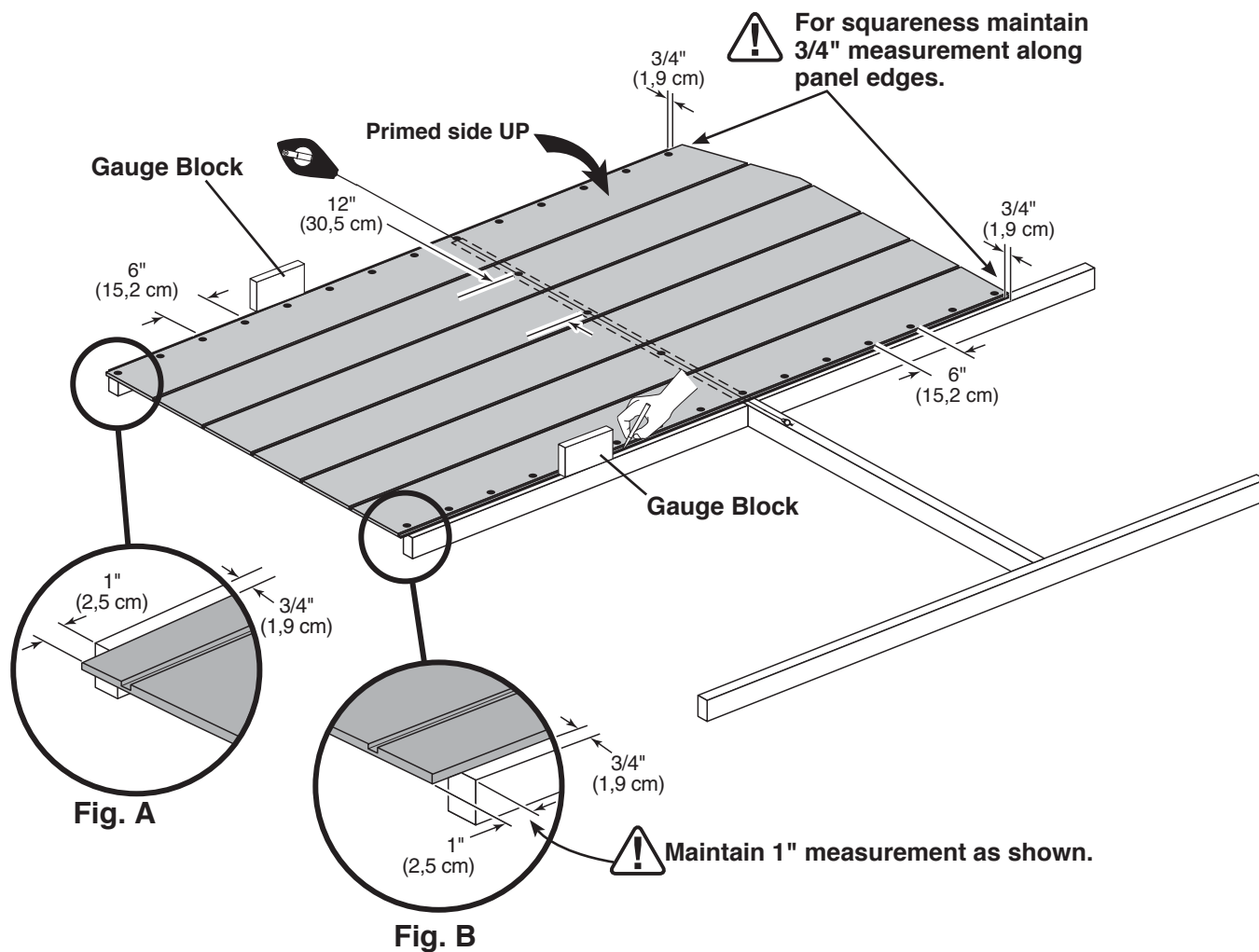
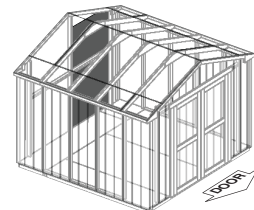

# BACK WALL PANELS

## PARTS REQUIRED:

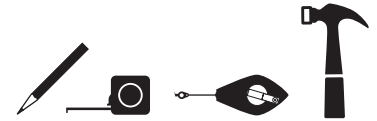
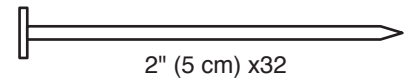
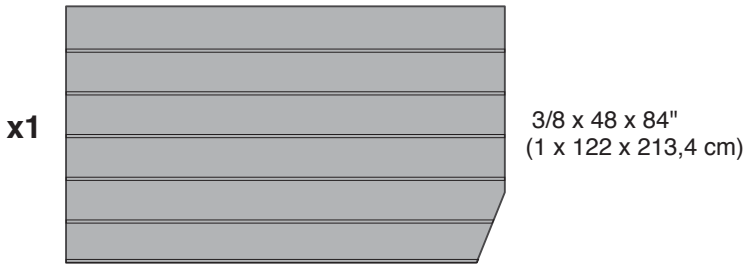

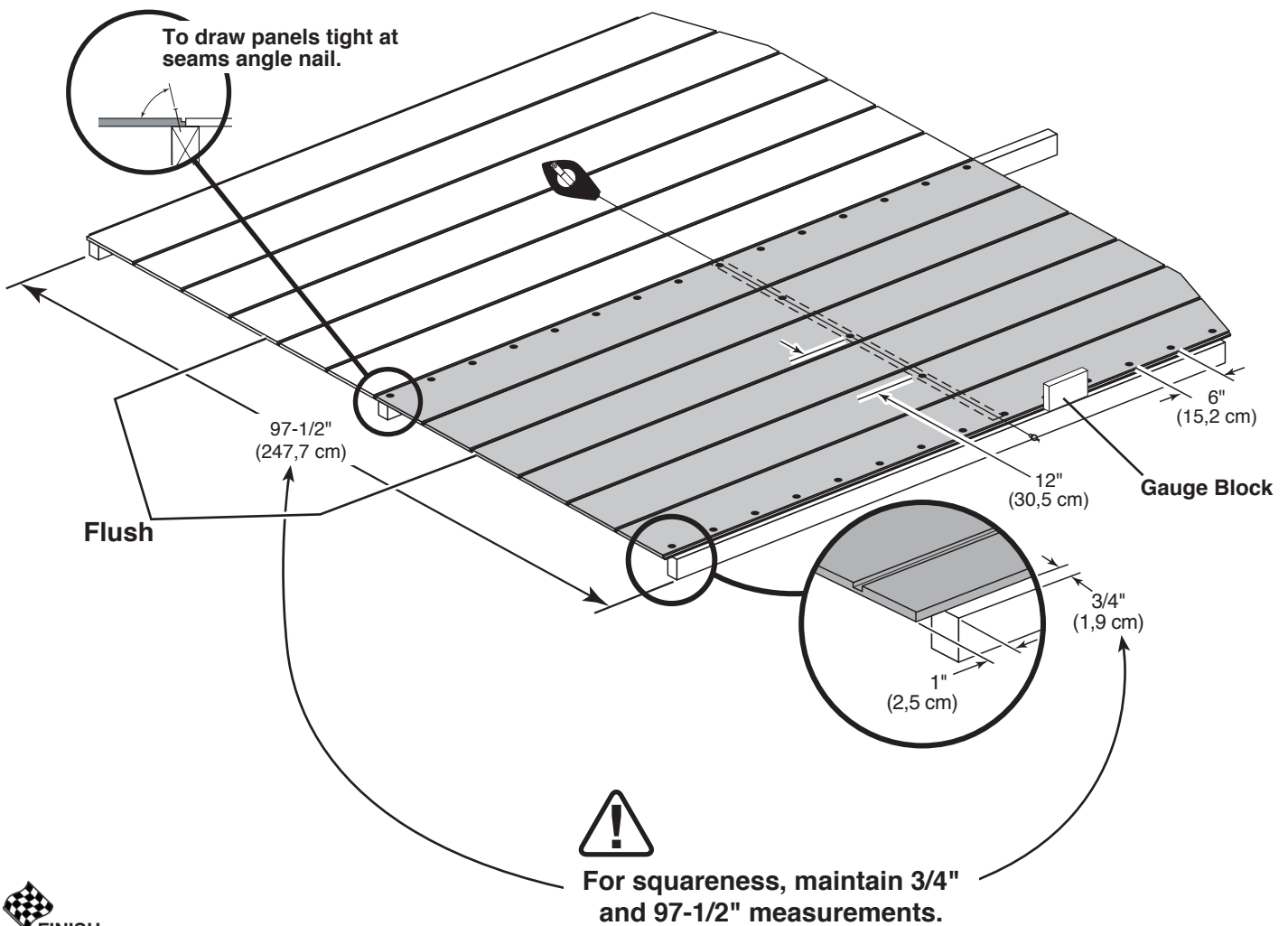
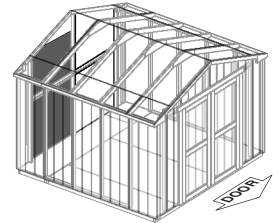

- 4 Place **RIGHT** panel on back frame as shown with primed side facing up.
- 5 Use a 3/4" gauge block at edges of panel.
- 6 Nail using 2" nails 6" apart on edges and 12" apart inside panel.



You have finished attaching your back wall panels

# WING WALL PANELS

## PARTS REQUIRED:

- x2  RIGHT
- x2  LEFT
- x4 **OY**  
2 x 3 x 72" (5 x 7,6 x 183 cm)

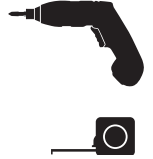
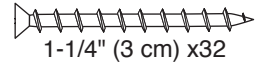

### ✓ BEGIN

- 1 You will assemble **TWO RIGHT** and **TWO LEFT** wing walls.
- 2 Place **OY** on floor.  Place a wing wall panel primed side down onto **OY** (Fig. A) and flush to panel edges as shown.
- 3 Secure flush to edges using eight 1-1/4 screws 10" apart.
- 4 You have finished building two sets of wing wall assemblies. Set **ONE LEFT** and **ONE RIGHT** aside. Continue building your back wall.

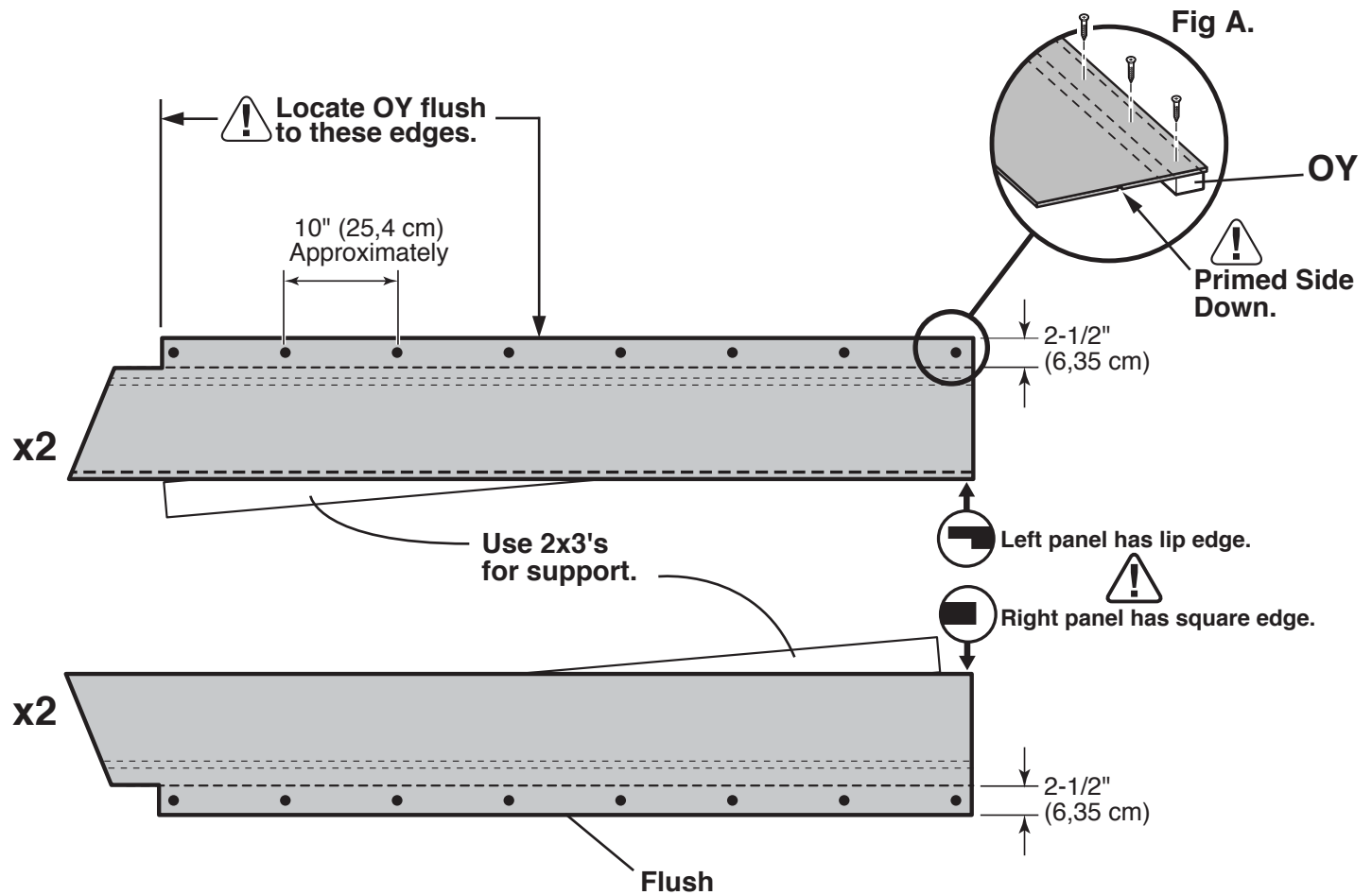
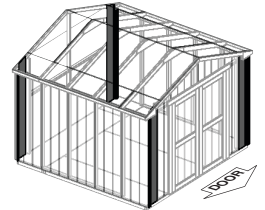

# BACK WALL WING PANELS

## PARTS REQUIRED:

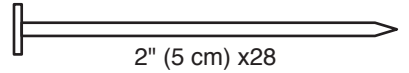

- x1  Pre-assembled **LEFT**
- x1  Pre-assembled **RIGHT**



**5** Place wing wall assemblies onto frame with bottom of panels flush.

**6** Nail left and right wing wall assemblies onto back wall frame using 2" nails 6" apart.



Do not nail in groove.

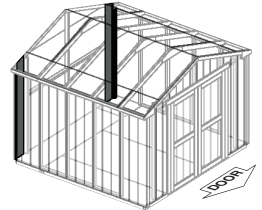

**FINISH**

**7** You have finished attaching your wing walls.

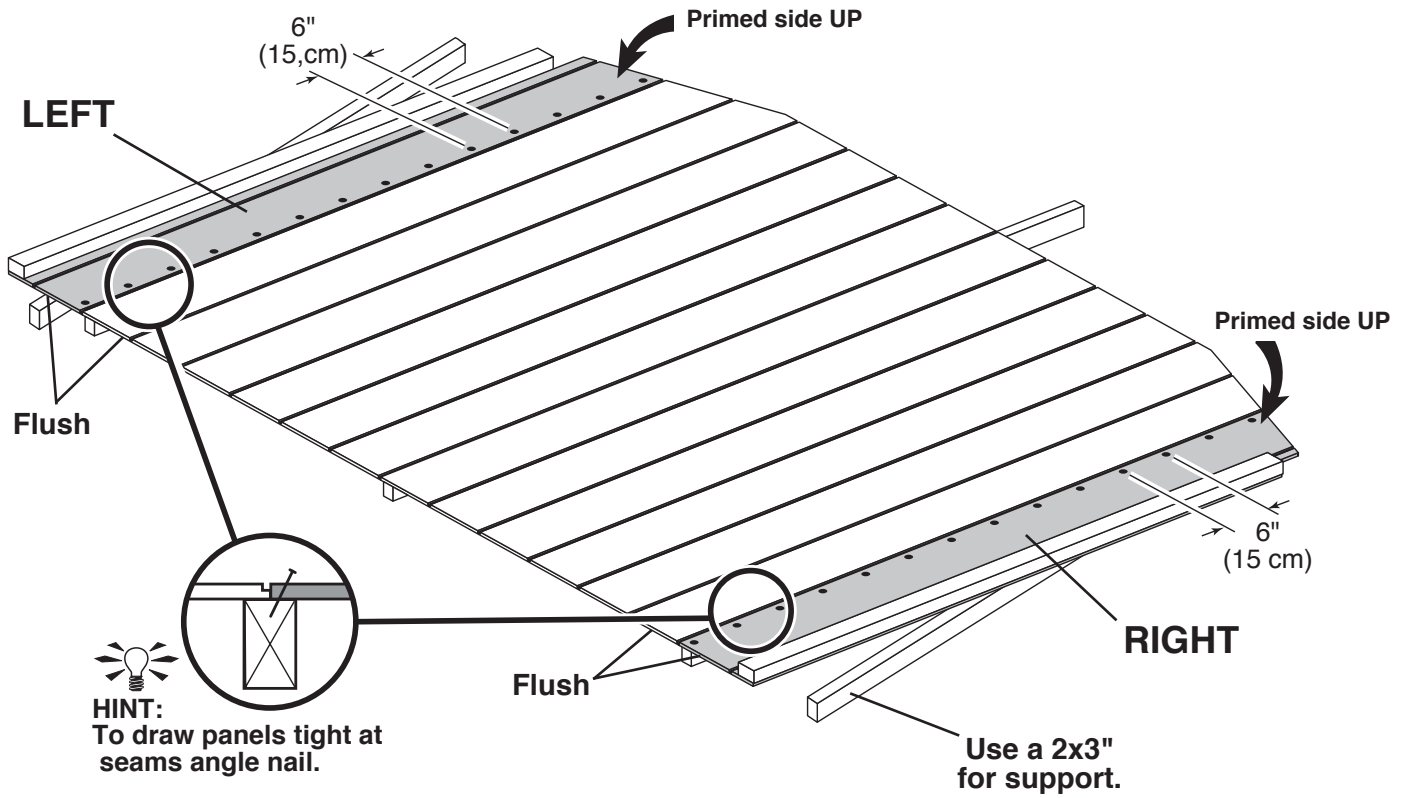



# BACK WALL GABLE PANELS

## PARTS REQUIRED:

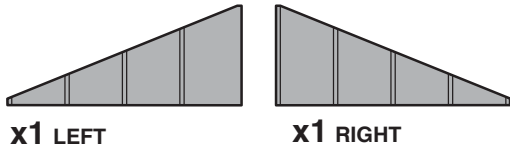

**3/4" GAUGE BLOCK**

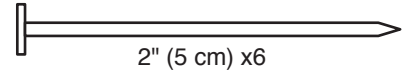

### ✓ BEGIN

**1** Place left gable panel onto frame primed side up and flush to left panel.  
**NOTE:** Panel grooves will not align.

**2** Use a 3/4" gauge block at edge of panel. Nail using 2" nails along edge as shown.

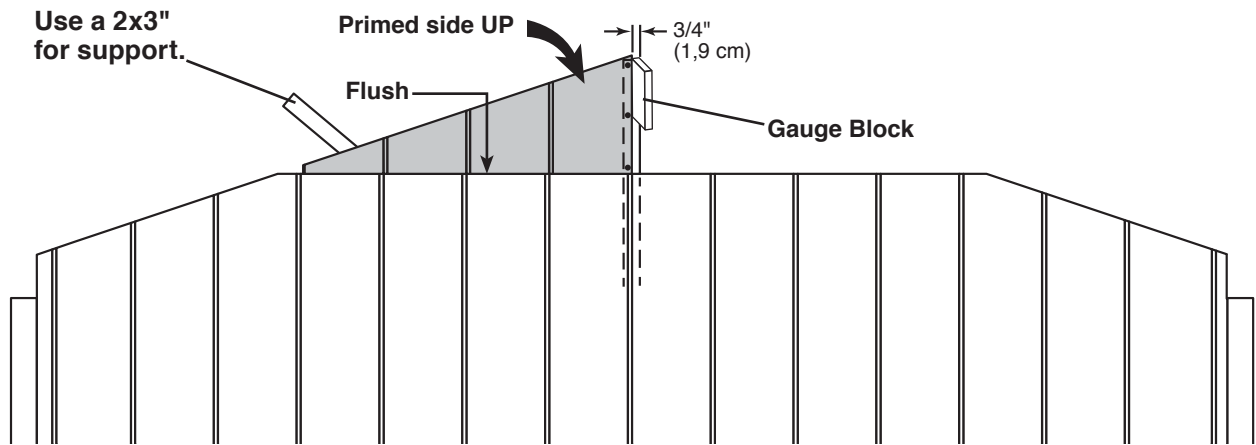
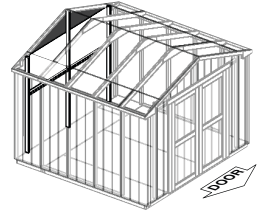

**3** Place right gable panel onto frame primed side up and flush to left panel.  
**NOTE:** Panel grooves will not align.

**4** Nail using 2" nails along edge as shown.

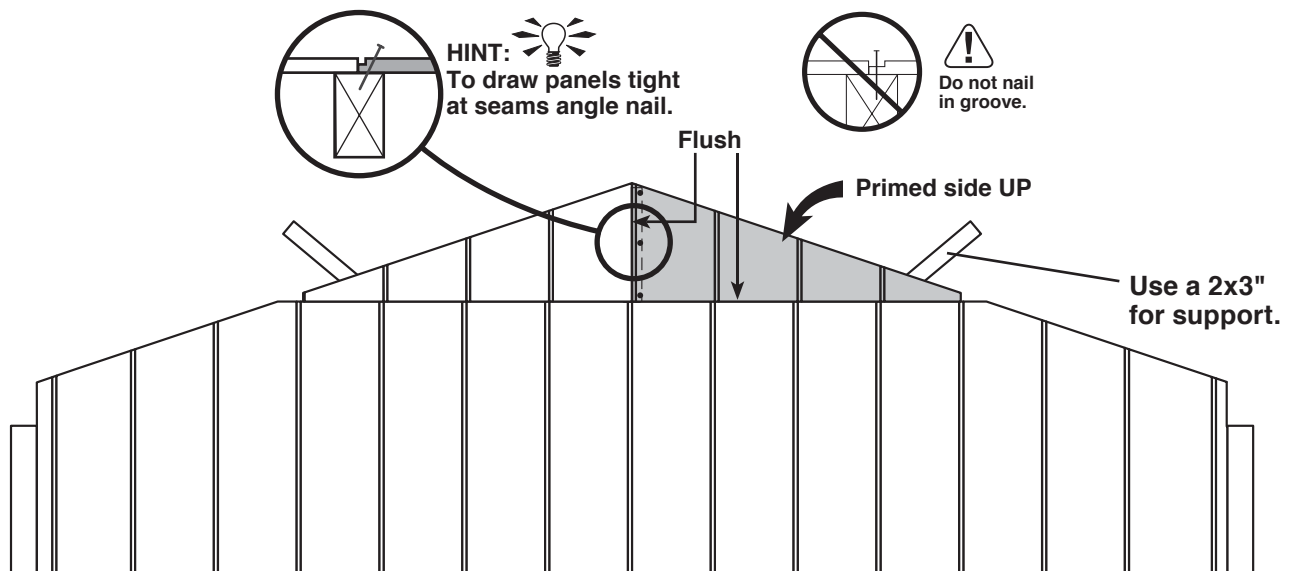

**5** You have finished building your back wall.

## FRONT WALL FRAME

### PARTS REQUIRED:

x1 **LT**  
2 x 3 x 22-1/8" (5 x 7,6 x 56 cm)

x2 **PB**  
2 x 3 x 77" (5 x 7,6 x 196 cm)

x1 **PR**  
2 x 3 x 94-1/2" (5 x 7,6 x 240 cm)

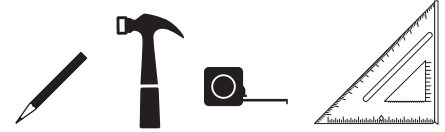
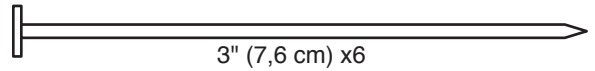

### ✓ BEGIN

- 1 Lay out two **PB**, one **PR** and one **LT** on edge on floor.
- 2 Nail two **PB** to **PR** with two 3" nails at each end.
- 3 Ensure **LT** is centered with **PR** and nail in place with two 3" nails.

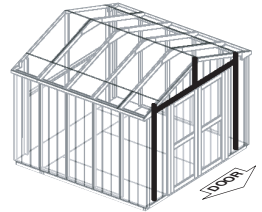

### FINISH

- 4 You have finished building your front wall frame.

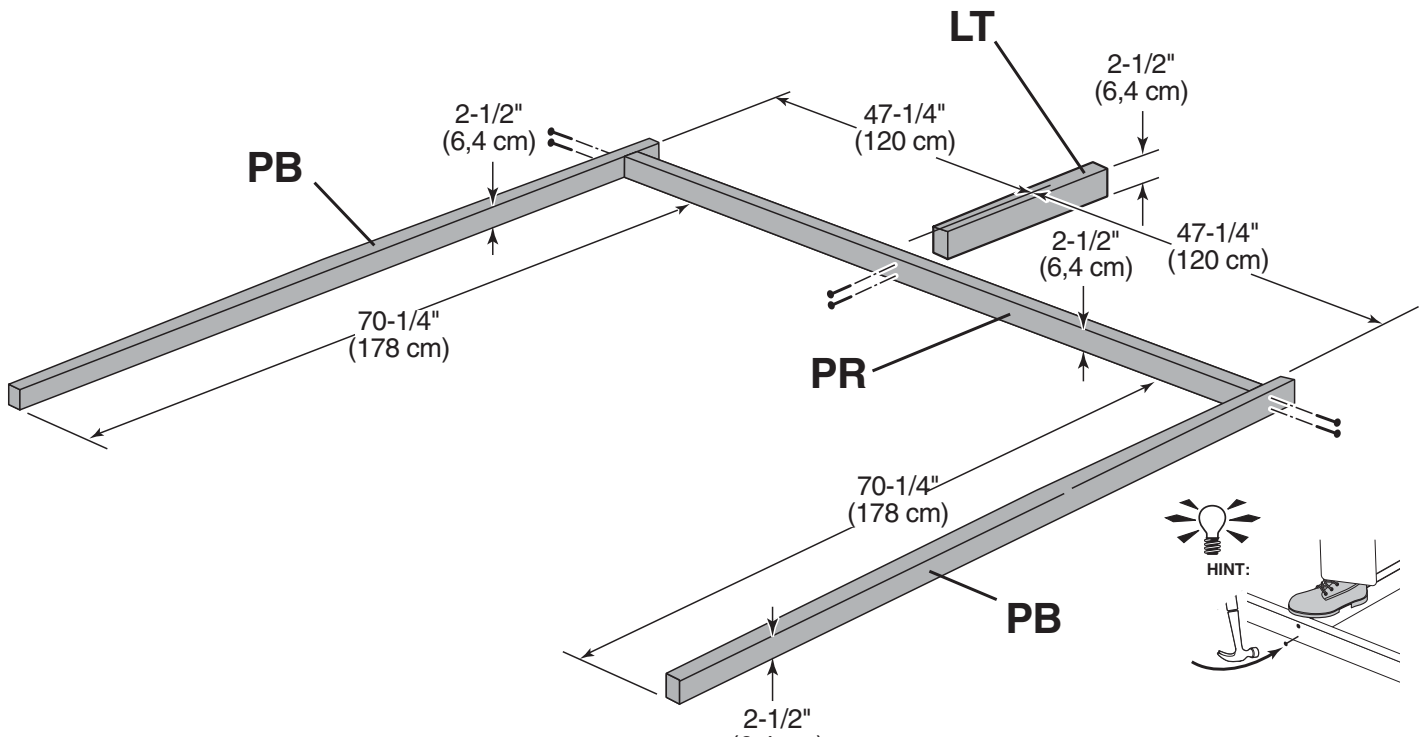

# FRONT WALL PANELS

## PARTS REQUIRED:

x1

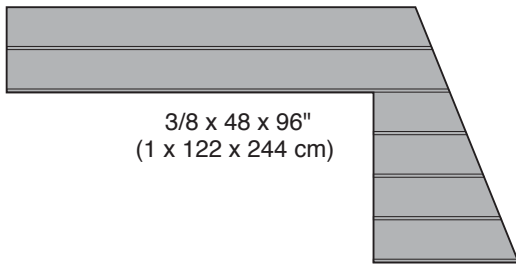

**GAA**  
3/4" GAUGE  
BLOCK

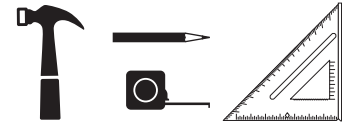
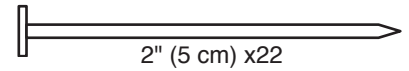

✓ **BEGIN**

- 1 Place **LEFT** panel on front frame as shown with primed side up.
- 2 Use a 3/4" gauge block on edges of panel. Be sure to maintain 1" measurement between bottom edge of frame and bottom edge of panel (**Fig. A**).
- 3 Nail panel to frame with 2" nails 6" apart.

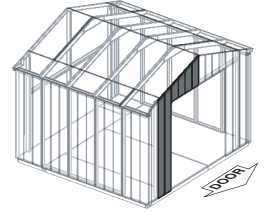

! **Maintain 1" measurement as shown.**

! **For squareness, maintain 3/4" measurements along panel edges.**

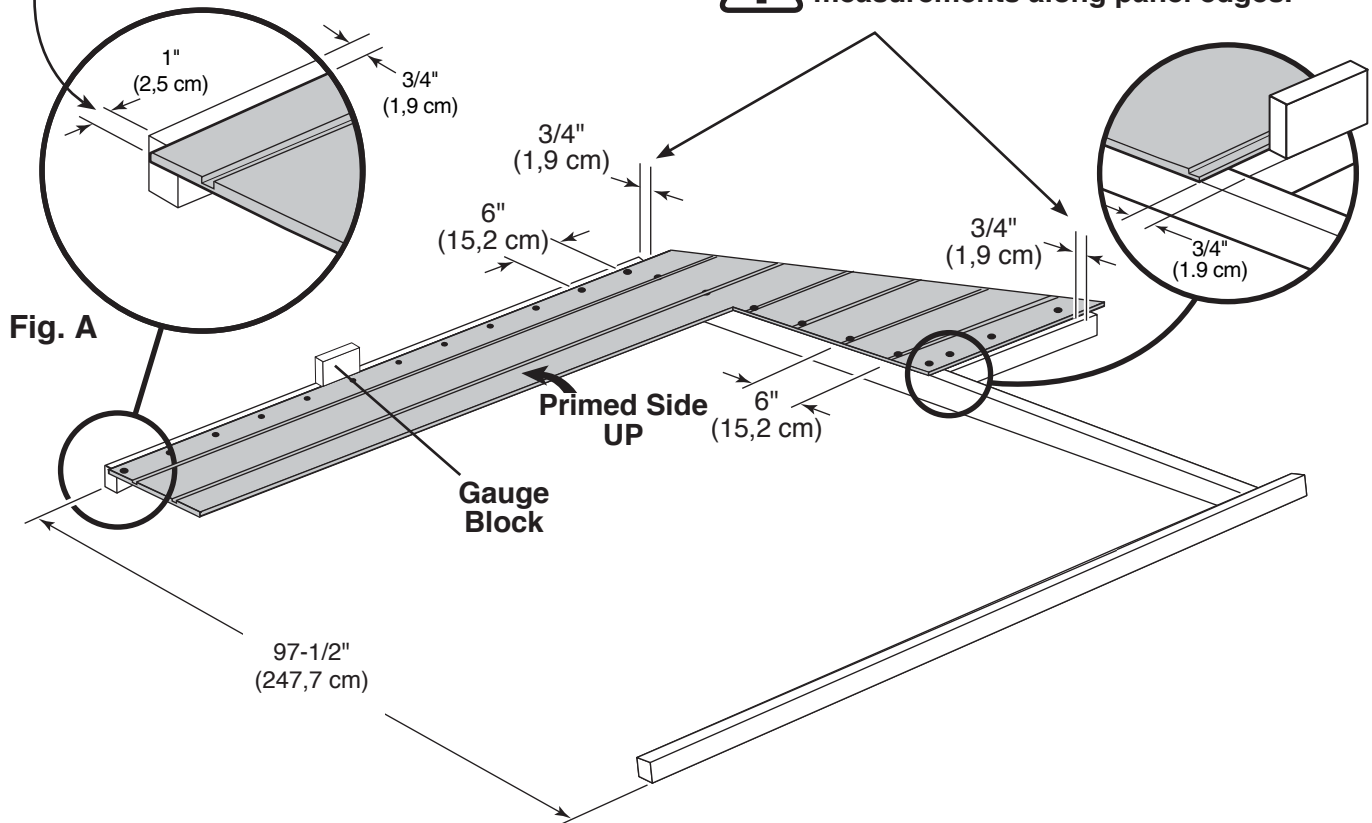

# FRONT WALL PANELS

## PARTS REQUIRED:

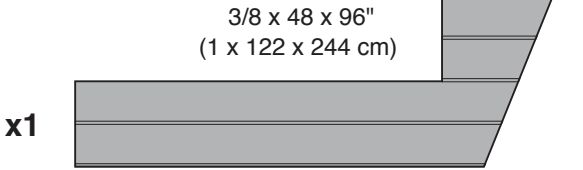

x1

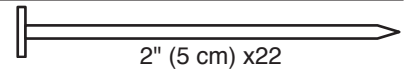

3/4" GAUGE  
BLOCK



- 4 Place **RIGHT** panel on front frame primed side up.
- 5 Use a 3/4" gauge block on edges of panel.
- 6 Nail panel to frame with 2" nails 6" apart.

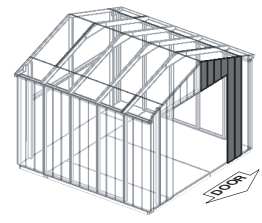
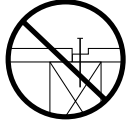

To draw panels tight at  
seams angle nail.

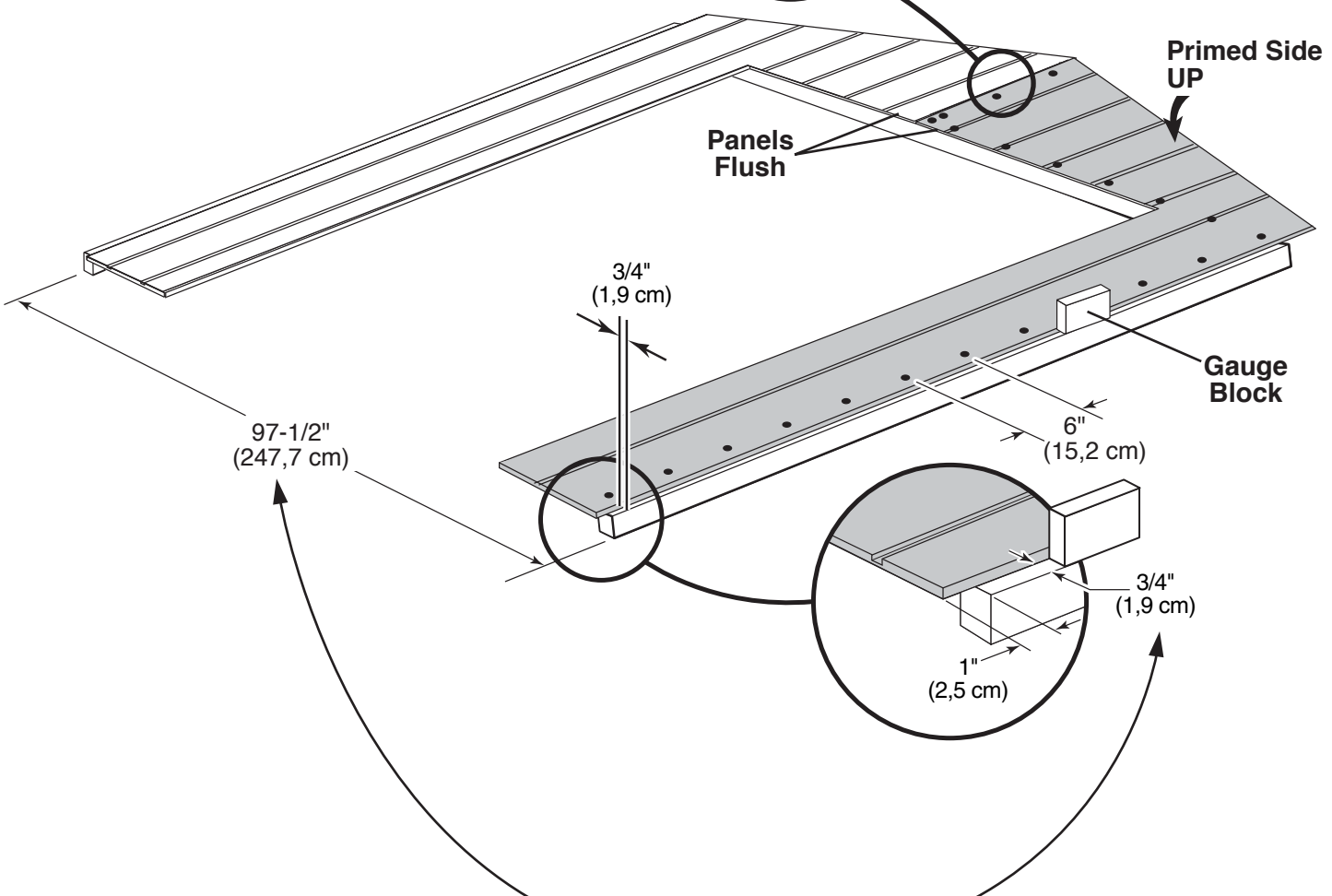
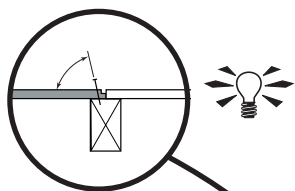

For squareness, maintain 3/4" and 97-1/2" measurements.

# FRONT WALL PANELS

## PARTS REQUIRED:

- x1  Pre-assembled **LEFT**
- x1  Pre-assembled **RIGHT**

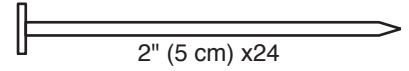

**7** Place wing wall panels onto frame with bottom of panels flush.

**8** Nail left and right wing wall assemblies using 2" nails 6" apart.

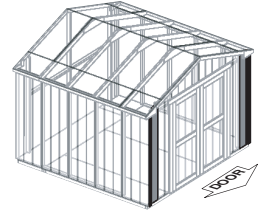

**9** You have finished attaching your wing walls.

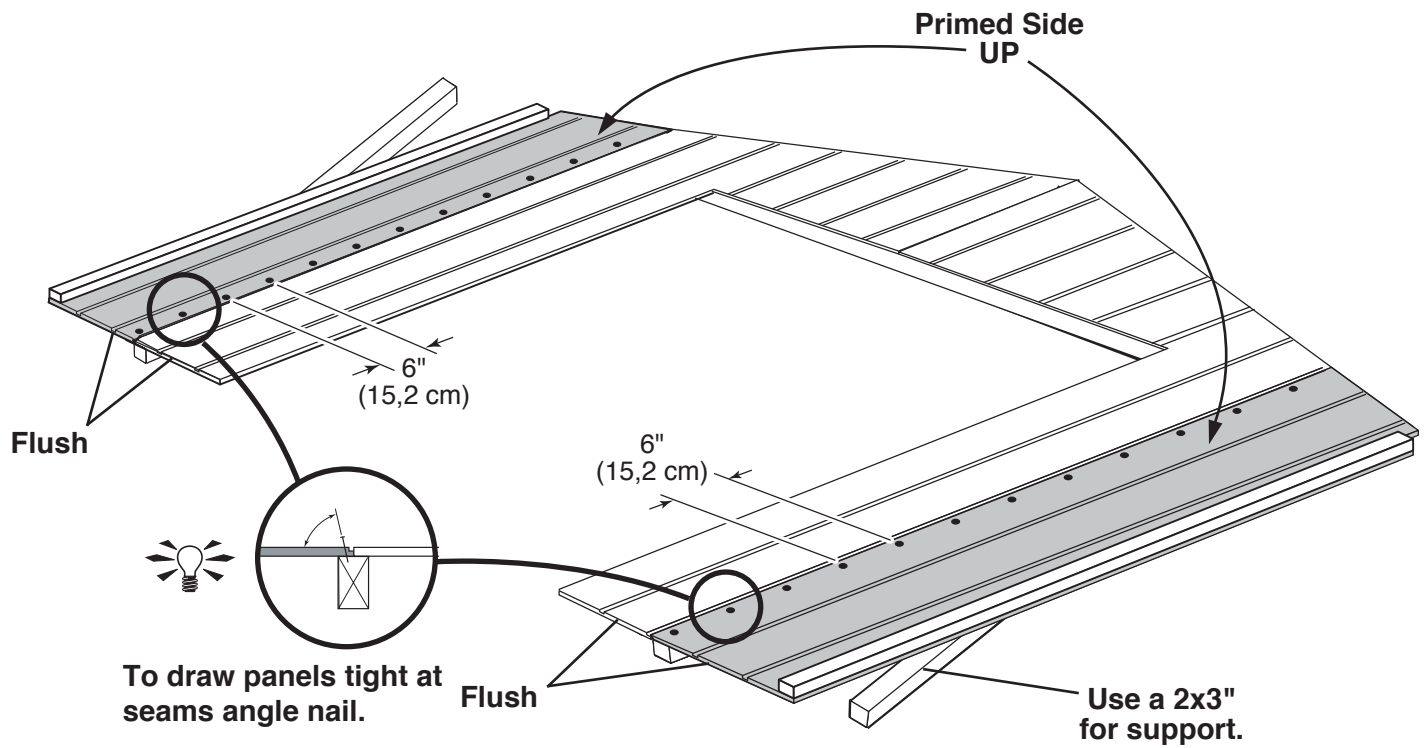

# SIDE WALL FRAMES

## PARTS REQUIRED:

x2 **NH**  
2 x 3 x 46-1/4" (5 x 7,6 x 117,5 cm)

x8 **OV**  
2 x 3 x 69" (5 x 7,6 x 175 cm)

x2 **OZ**  
2" x 3" x 70-1/4" (5 x 7,6 x 178,4 cm)

x2 **OZ**  
7/16 x 2-1/2 x 73-1/2" (1,1 x 6,3 x 187 cm)

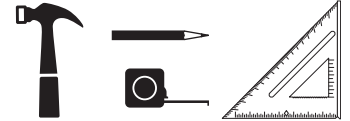
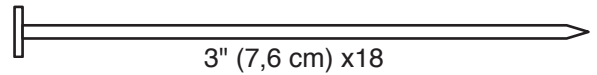

### ✓ BEGIN

**1** Orient parts on edge on floor. Measure and mark from end of boards.  
**IMPORTANT! You will build two walls the same.**

**2** Use two 3" nails at each mark.

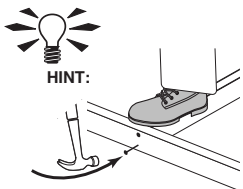
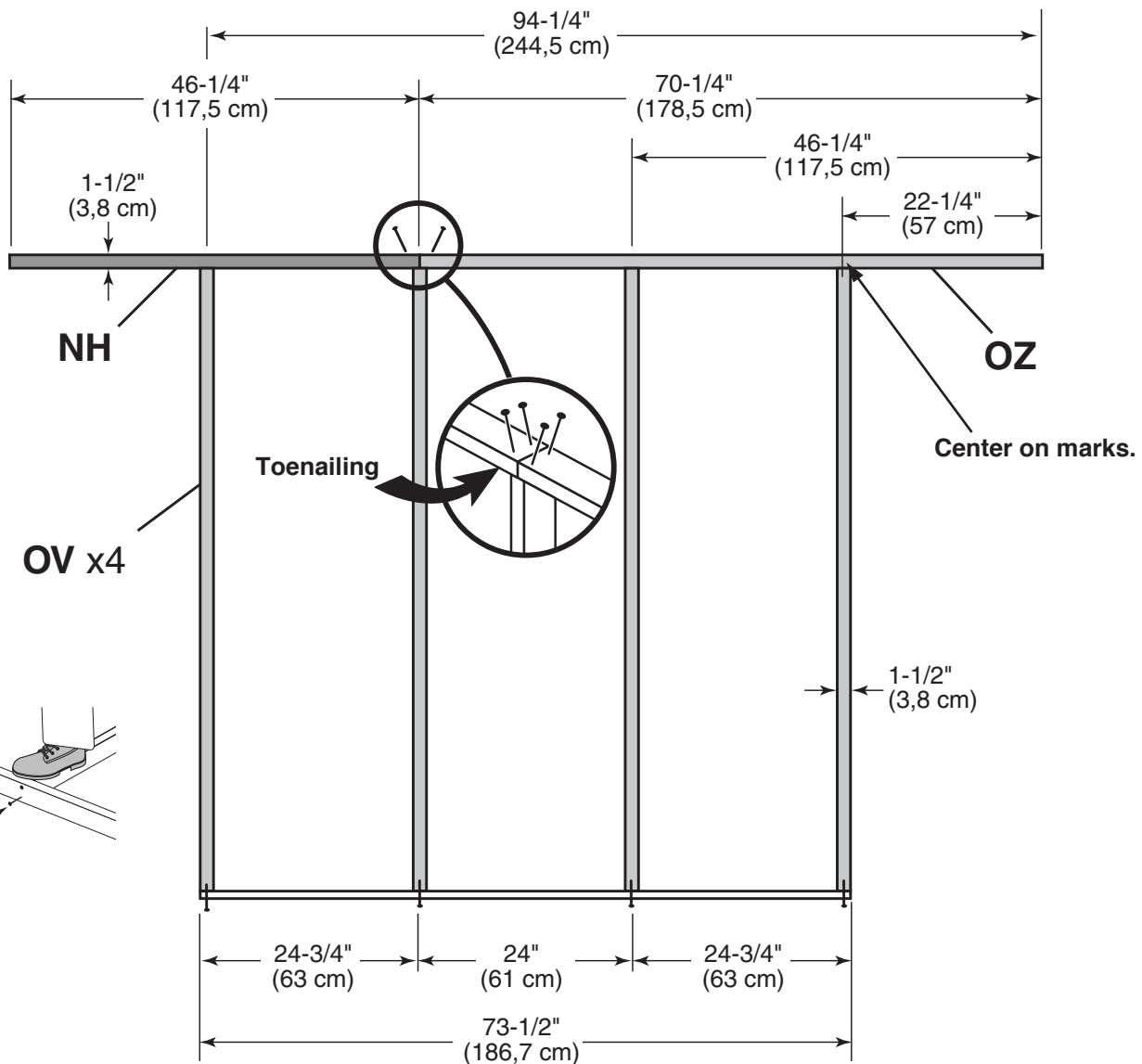
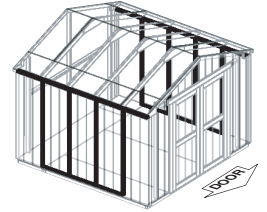

## SIDE WALL FRAME- SOFFIT

### PARTS REQUIRED:

x2   
 3/8 x 5 x 21-1/4" (0,9 x 12,7 x 54 cm)

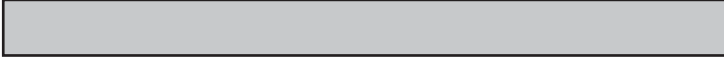
x2   
 3/8 x 5 x 96" (0,9 x 12,7 x 244 cm)

  
 1-1/4" (3,2 cm) x28

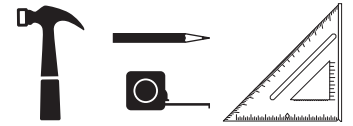

**3** Place panels onto 2x3 with primed side against 2x3 (Fig A).

 **Keep panels flush along entire edge of 2x3 top plate (Fig A).**

**4** Attach soffit panels flush to 2x3 (Fig A) and with 3/8" offset at ends (Fig. B, C) using fourteen 1-1/4" screws.

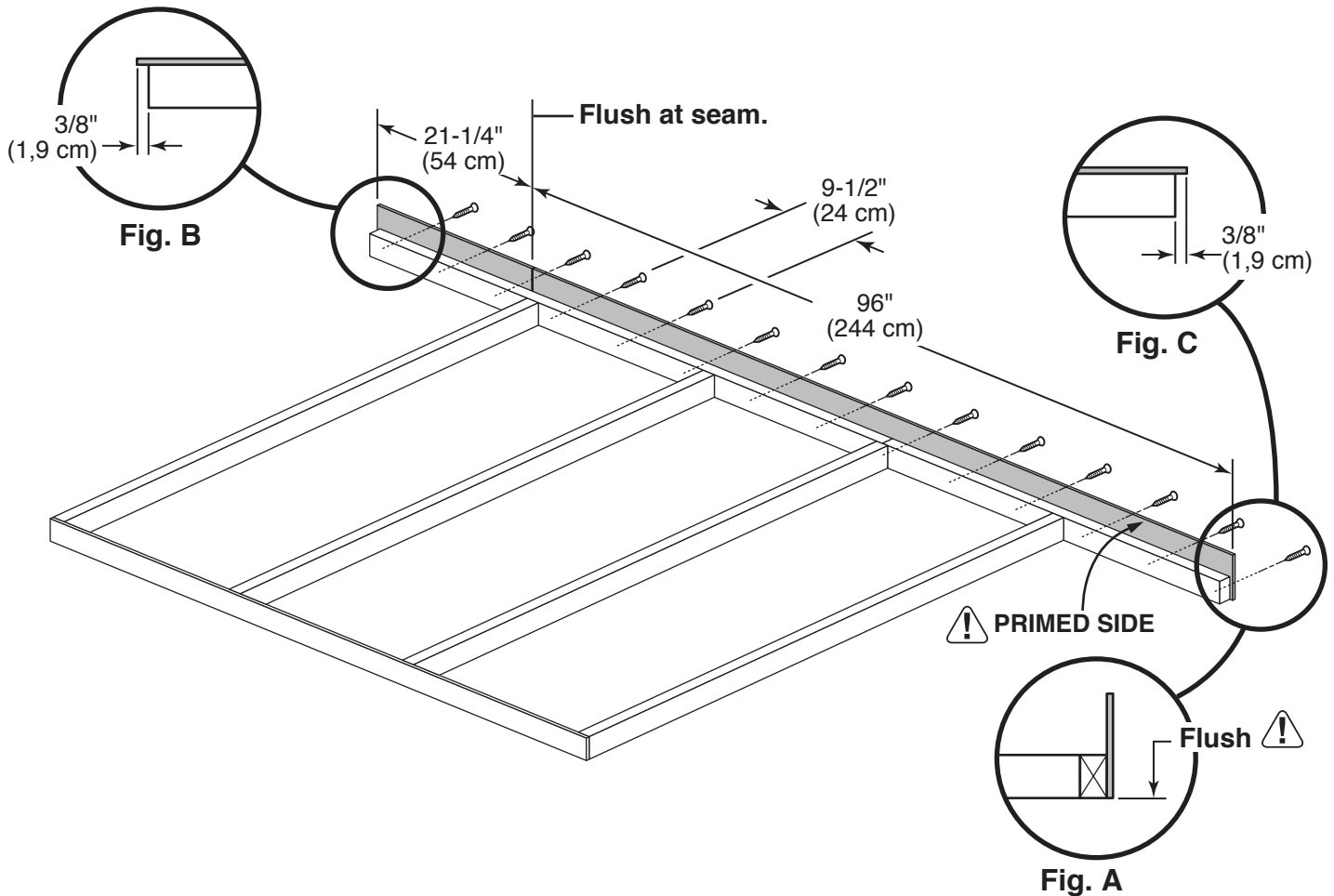
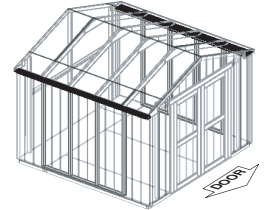

# SIDE WALL PANELS

## PARTS REQUIRED:

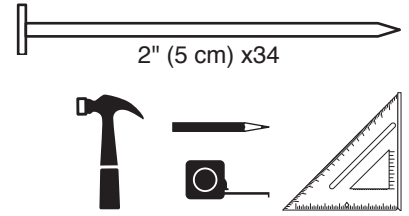
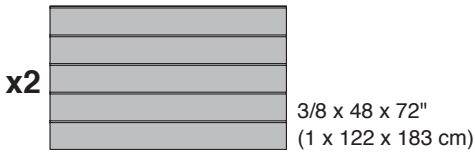

- ⚠️ **Ensure your wall frame is square by installing one panel and squaring frame.**
- 5** Place the **48 x 72"** panel onto wall frame with primed side up as shown. Note the lip and square edges.

Use the gauge block to mark the 3/4" measurement on the wall stud. Locate the panel flush under the soffit panel. Secure panel with two 2" nails in the corners (**Fig. A**).

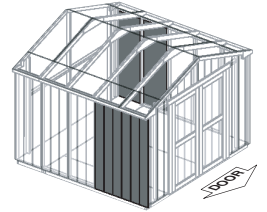

- 6** Move to the opposite end. Using the long edge of the panel as a lever move the panel side-to-side until you have a 3/4" measurement on the wall stud. Secure corner with two 2" nails.
- 7** Nail the panel using 2" nails 6" apart on edges and 12" apart inside panel.



⚠️ **For squareness maintain 3/4" and flush under soffit panel.**

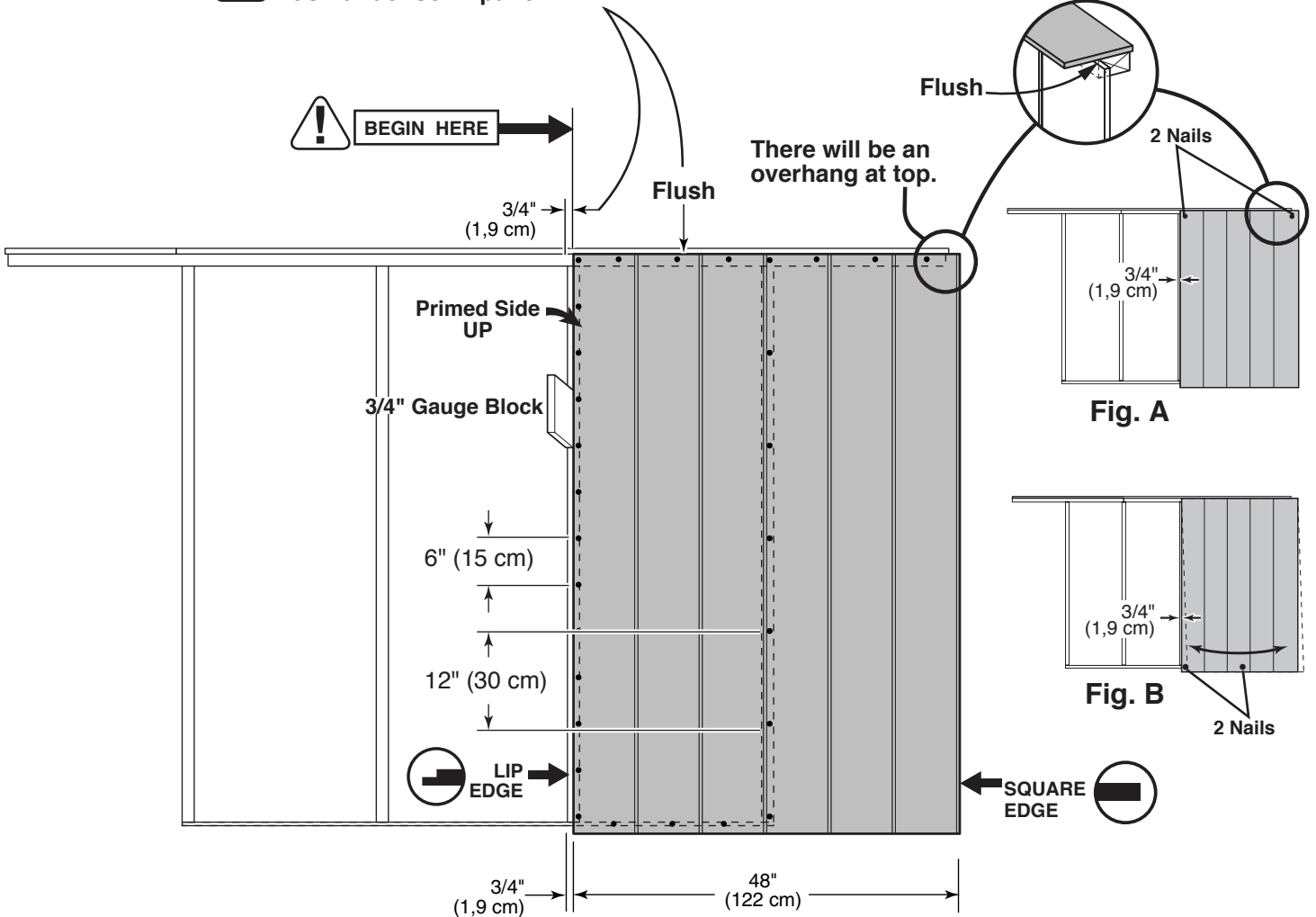



# SIDE WALL PANELS

## PARTS REQUIRED:

x2  3/8 x 23-7/8 x 72" x2  
(1 x 61 x 183 cm)

 3/8" x 48" x 72"  
(1 x 122 x 183 cm)

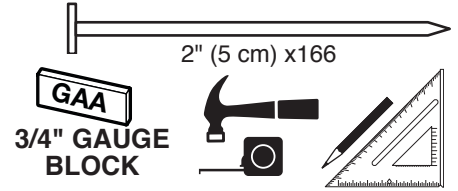

 For squareness maintain 3/4" and flush under soffit panel.

 To draw panels tight at seams angle nail.

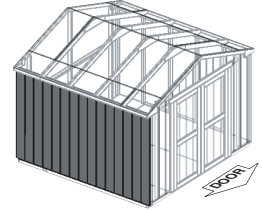

**8** Place 48" panel on frame as shown with primed side facing up. **NOTE THE SQUARE AND LIP EDGES.**

Nail using 2" nails 6" apart on edges and 12" apart inside panel.

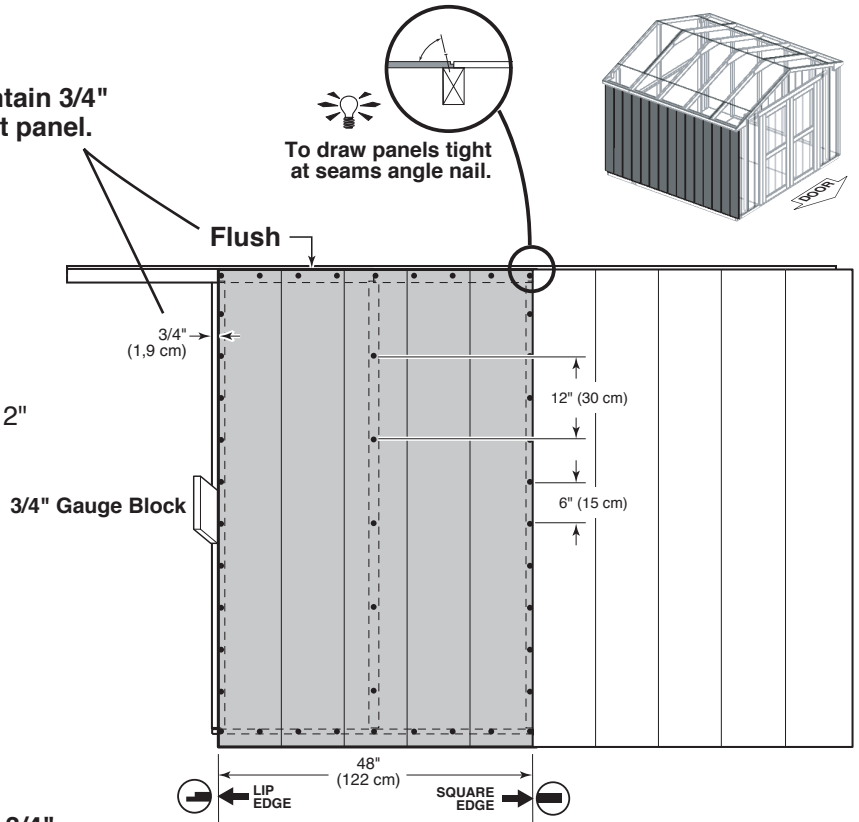

 For squareness maintain 3/4" and flush under soffit panel.

**9** Place 23-7/8" panel on frame as shown with primed side facing up. **NOTE THE SQUARE AND LIP EDGES.**

Nail using 2" nails 6" apart on edges.

Carefully flip your sidewall over. Repeat **STEPS 1-8** to assemble your second side wall.

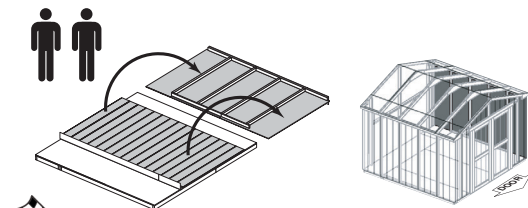
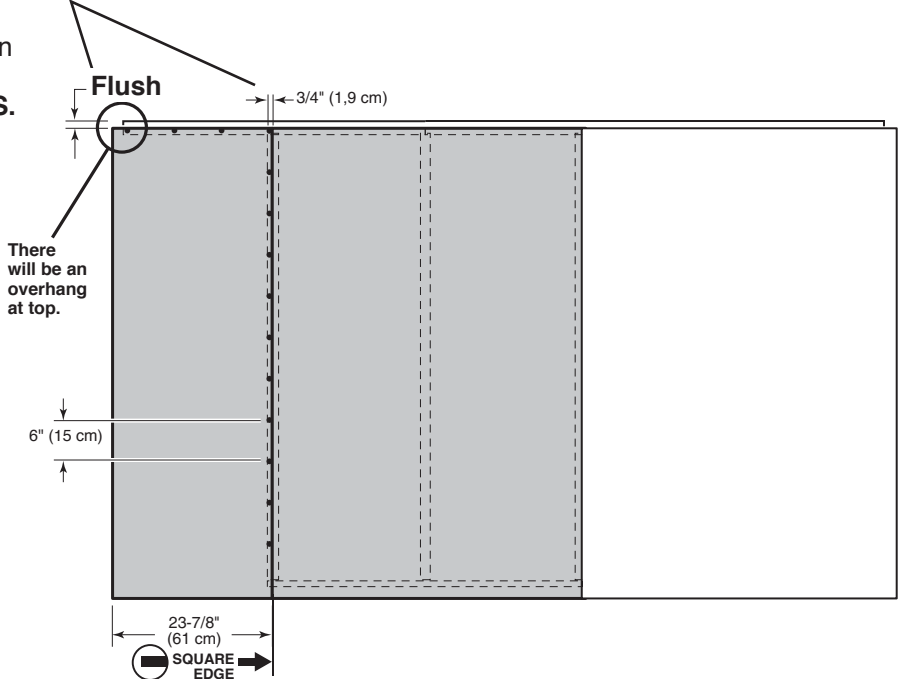

 **FINISH**

**10** You have finished building both of your side walls.

# BACK WALL INSTALLATION

## PARTS REQUIRED (TEMPORARY):

x1 **OO**  
 1-1/4 x 2-1/2 x 69" (3,2 x 7,6 x 175,3 cm)

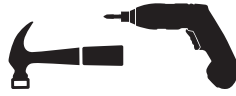
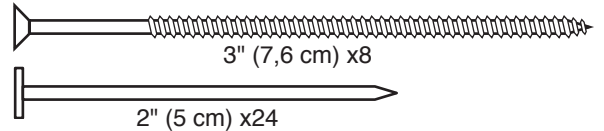

### ✓ BEGIN

- 1 Center back wall assembly on the 120" (305 cm) floor dimension.
- 2 Use **OO** as a temporary brace. Secure with two 3" screws.

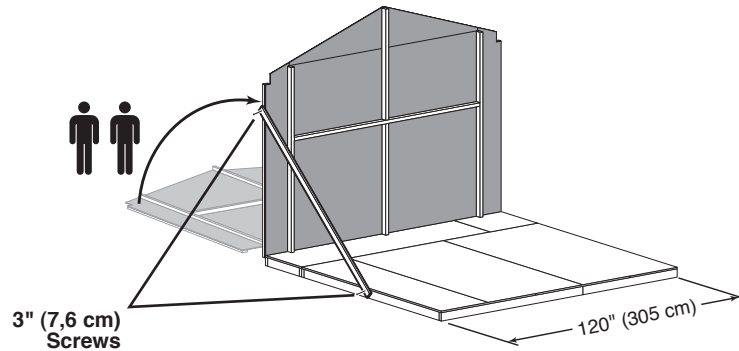
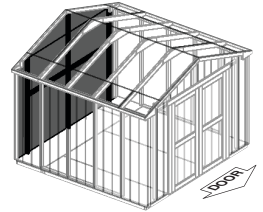

- 3 First, nail lower edge of panel to floor frame using 2" nails 6" apart. Angle nail to hit floor frame (**Fig. A**).
- 4 Screw back wall uprights to floor using two 3" screws (**Fig. B**).



### FINISH

- 5 You have finished standing your back wall.

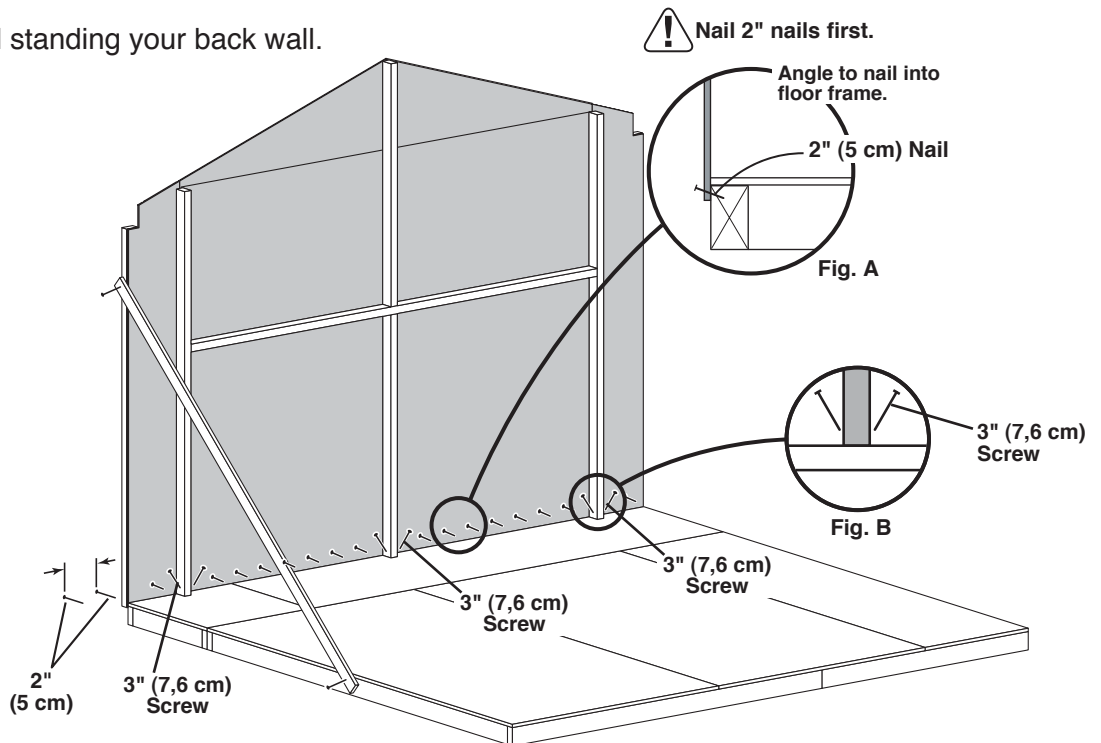

# SIDE WALLS INSTALLATION

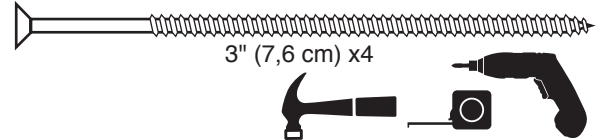
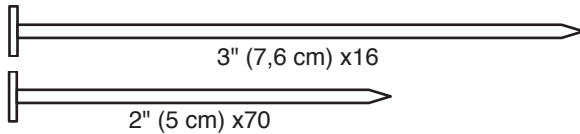

## ✓ BEGIN

Stand right sidewall on floor.



⚠ It is important to secure the sidewall in the following order.

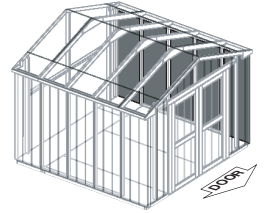

- 1 Center sidewall on floor front to back.

Rest the top of the sidewall so the soffit panel overlaps the backwall panel 3/8" (**Fig. A**).

Nail the lower sidewall corner to the backwall trim with one 2" nail (**Fig. B**).

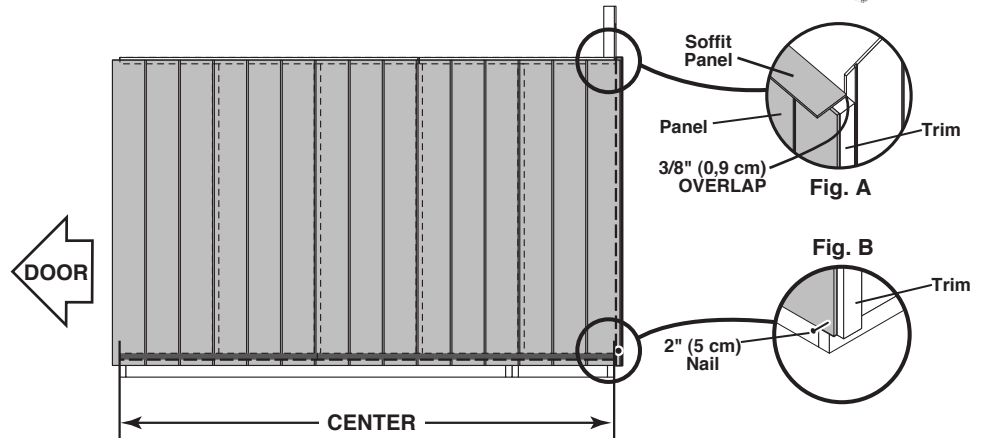

- 2 Be sure the measurement between the panel edge and the trim is the same along the entire length. Then secure with one 2" nail in the upper corner (**Fig. C**).

Nail along the panel edge into the trim using 2" nails spaced 6" apart.

Nail along bottom of panel using 2" nails 6" apart. Angle nail to hit floor frame (**Fig. D**).

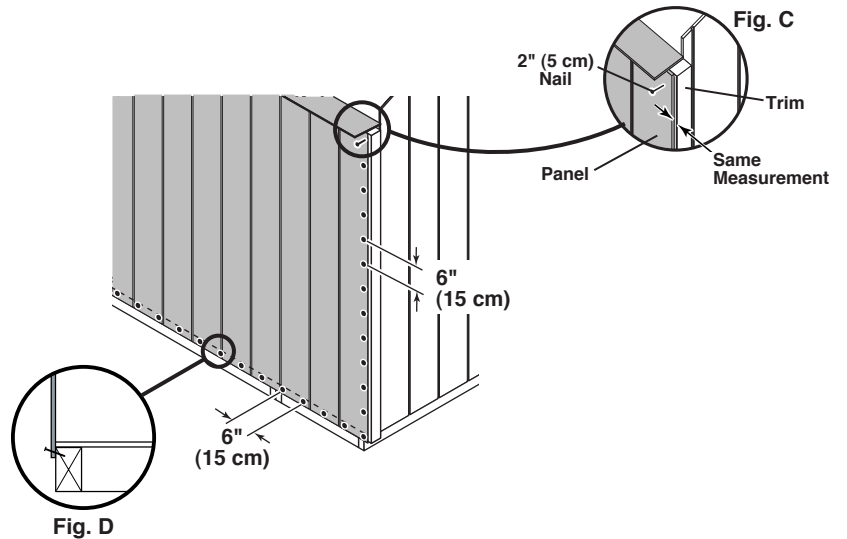

- 3 Nail down the bottom plate using two 3" nails between the wall studs.

Screw through the backwall trim into the top and bottom plates using one 3" screw (**Fig. E**).

Screw through the backwall trim using one 3" screw. Angle screw to hit floor frame (**Fig. F**).

Repeat process to secure the left sidewall.

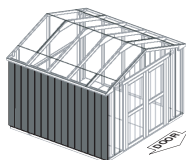
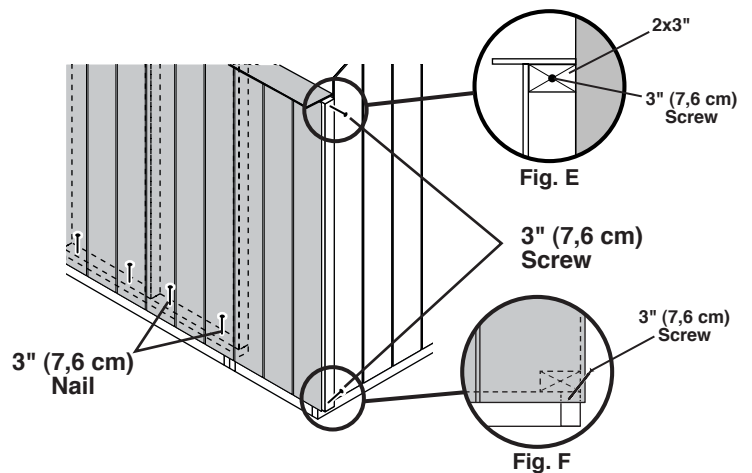

# FRONT WALL INSTALLATION

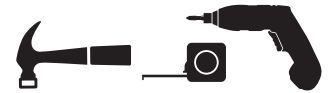
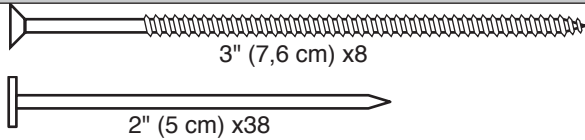

✓ **BEGIN**

Stand frontwall on floor. 

 It is important to secure the frontwall in the following order.

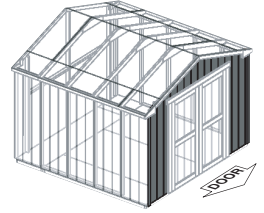

**1** Center frontwall on floor side-to-side.

The sidewall soffit will overlap the frontwall 3/8" (**Fig. A**).

Nail the frontwall flush to the floor using 2" nails 6" apart. Angle nails to hit floor frame (**Fig. B**).

Nail the lower sidewall corner to the frontwall trim with one 2" nail (**Fig. C**).

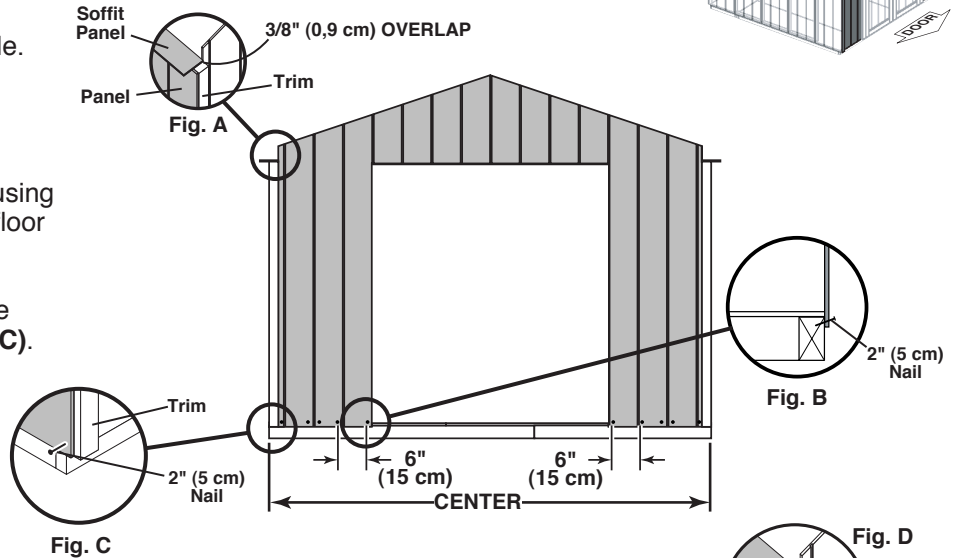

**2** Be sure the measurement between the panel edge and the trim is the same along the entire length. Then secure with one 2" nail in the upper corner (**Fig. D**).

Nail along the panel edge into the trim using 2" nails spaced 6" apart.

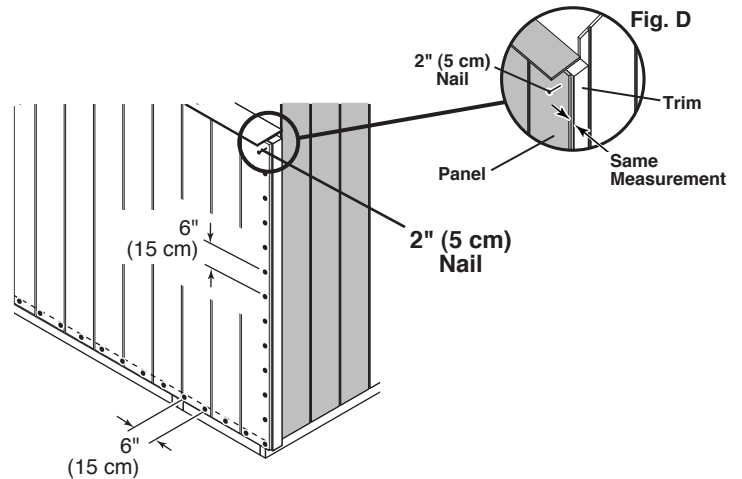

**3** Secure the frontwall frame using two 3" screws (**Fig. E**).

Screw through the frontwall trim into the top and bottom plates using one 3" screw (**Fig. F**).

Repeat process to secure the right side of the frontwall.

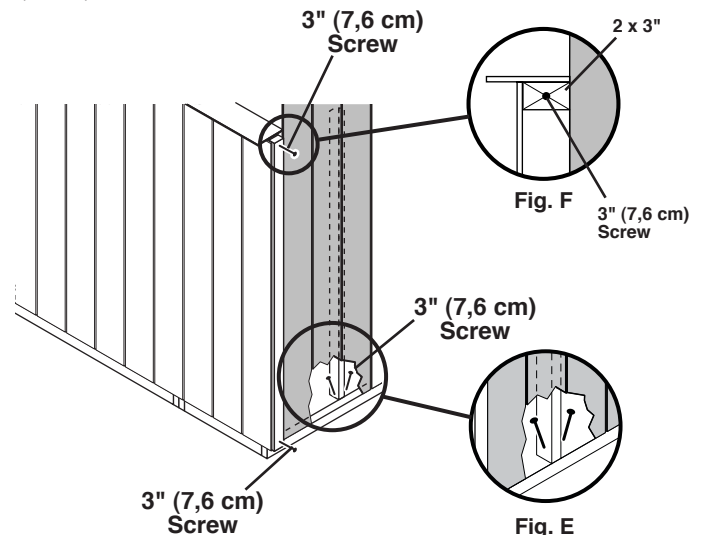

# GABLE TRIM

## PARTS REQUIRED:

x4 **CDD**  
2 x 3 x 58" (5 x 7,6 x 147,3 cm)

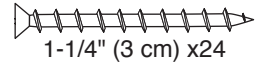

✓ **BEGIN**

**1** Position one **CDD** flush to front panel edge and center on right edge of groove (**Fig. A**). Attach trim with eight 1-1/4" screws from inside. Install two screws at seam (**Fig. B**).

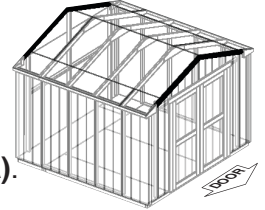

**2** Position second **CDD** flush to panel edge and flush to **CDD** already attached (**Fig. A**). Attach trim with eight 1-1/4" screws from inside. Install two screws at seam (**Fig. B**).

**3** Repeat steps 1-2 to attach the back trim.



**FINISH**

**4** You have attached your upper trim. Continue to attaching your endcaps.

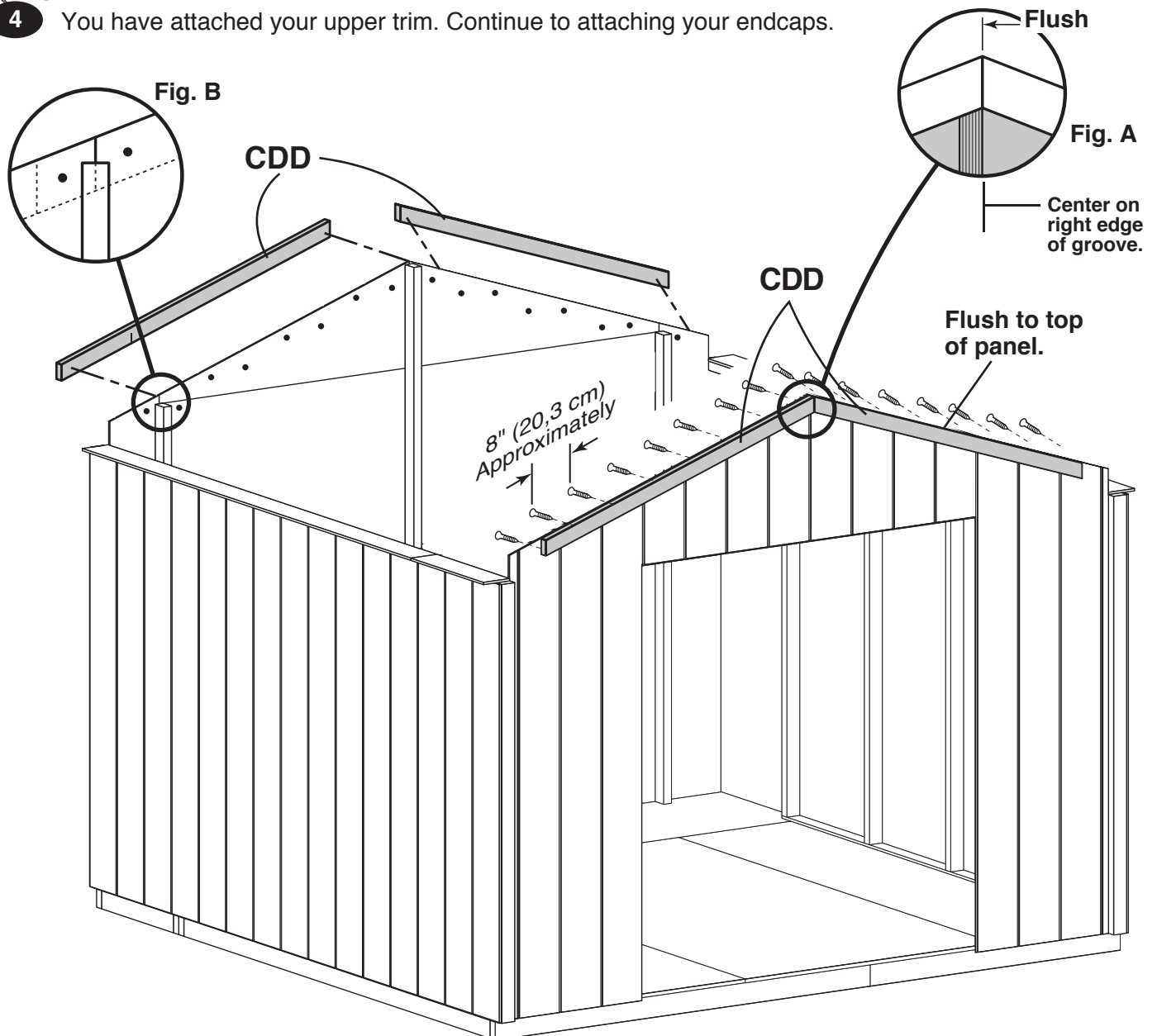

# BACK WALL GABLE TRIM

## PARTS REQUIRED:

x1 **XMA**  
 11/16 x 2-1/2 x 60-5/8" (1,7 x 6,3 x 154 cm)

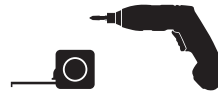

3/4" (1,9 cm) x11



✓ **BEGIN**  
**1**



Clamp or hold trim **XMA** onto gable panel seam and up against gable trim.  
 Ensure **XMA** is level.

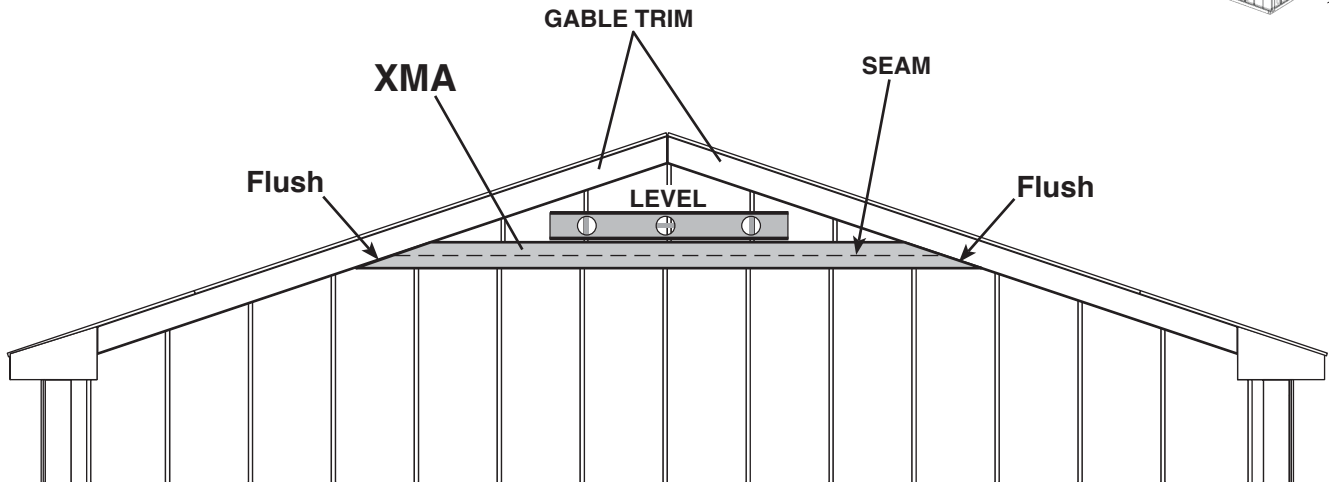
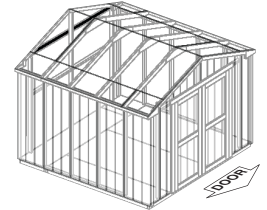

**2** *From the inside*, attach **XMA** with 3/4" screws as pattern shows.

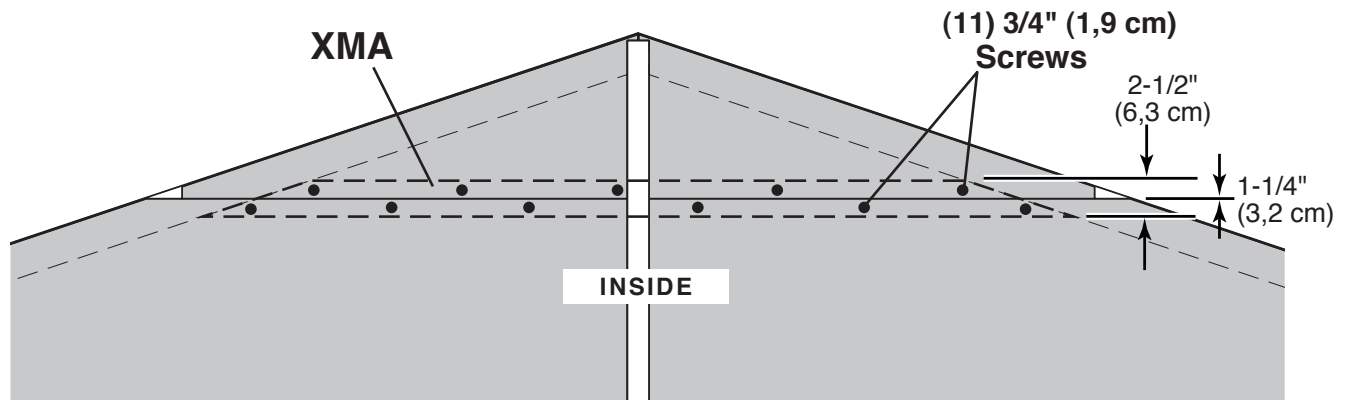

FINISH  
**3**

You have attached your back wall gable trim.

# TRIM / ENDCAPS

## PARTS REQUIRED:

x4 **GBB**  
1 x 3 x 7-1/2" (2,5 x 7,6 x 19 cm)

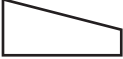
x4  3/4 x 5-1/8 x 8-3/8" (1,9 x 13 x 21,3 cm) **RIGHT PAINTED RED**  
**LEFT PAINTED GREEN**

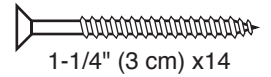

### ✓ BEGIN

**1** Glue 7-1/2" boards onto endcaps, and fasten with 1-1/4" screws, as shown.

**2** Repeat steps to build two more endcaps.

**3** Locate endcaps flush with upper trim and corner trim and attach each endcap from inside of shed using four 1-1/4" screws as shown (**Fig. A**).

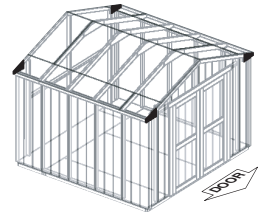

### FINISH

**4** You have attached your endcaps.

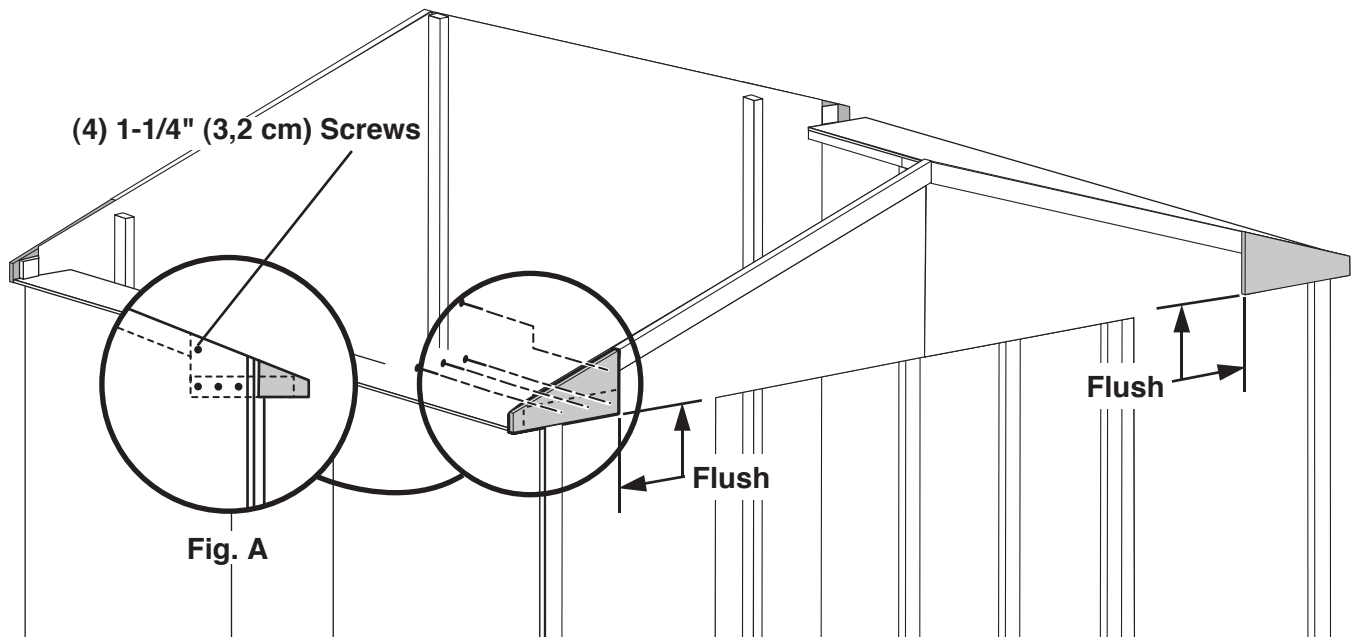
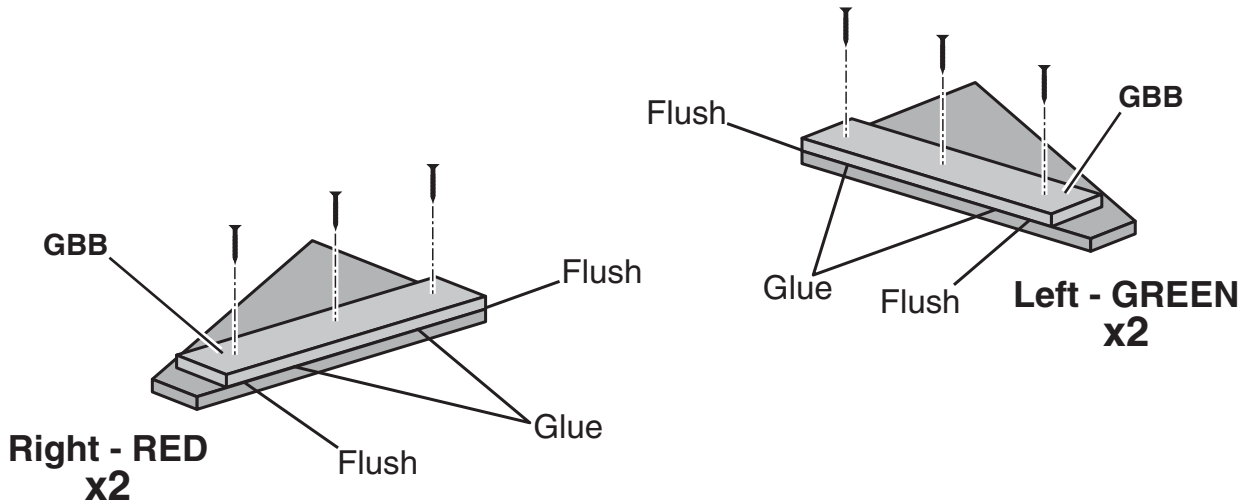

# RAFTERS

## PARTS REQUIRED:

x4

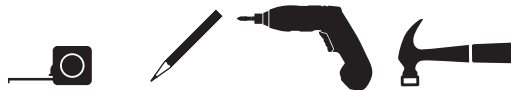
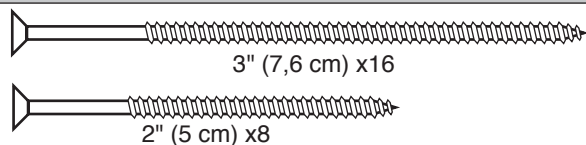
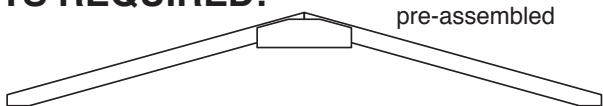

### ✓ BEGIN

**1** Locate rafters directly over studs and flush to overhang in wall frame (**Fig. A**). Check that you have the measurements shown. Screw through soffit panel into rafters using one 2" screw (**Fig. A**).

**2** Attach with two 3" screws at each end (**Fig. B**). Re-tighten 2" screws if necessary.

**3** Repeat steps to attach 4 rafters.

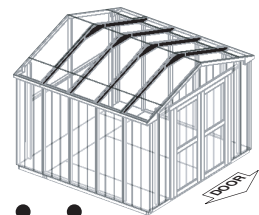

### FINISH

**4** You have attached your rafters.

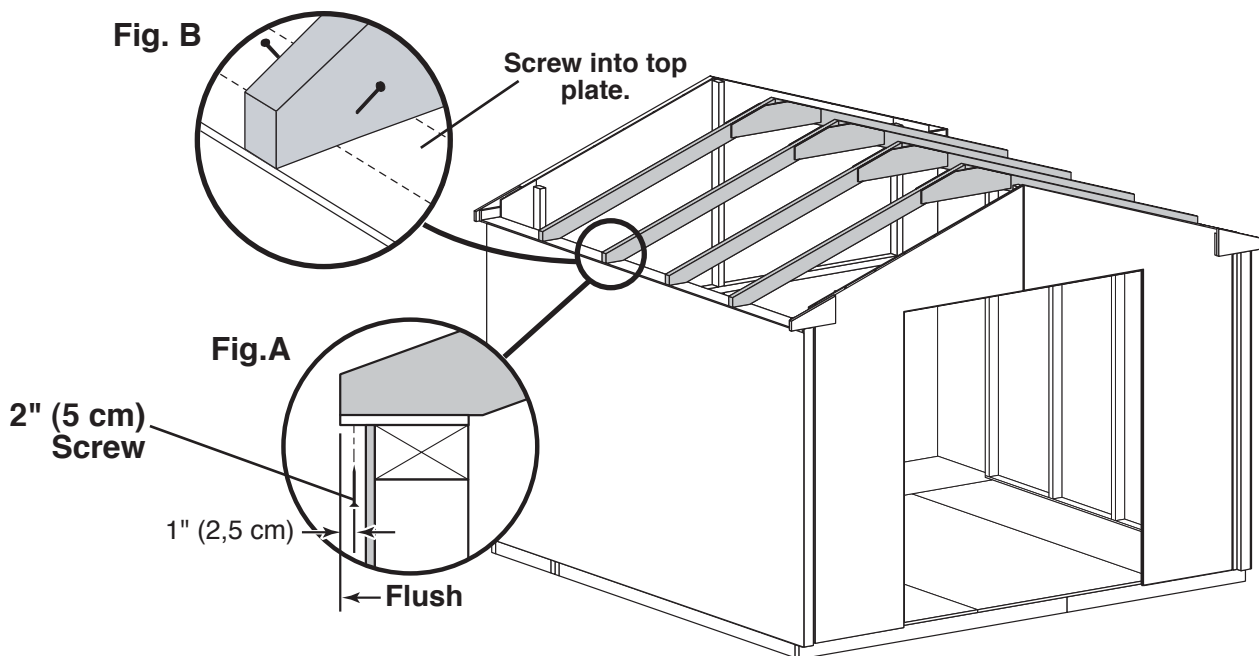

**NOTE:** Measurements from inside of panels

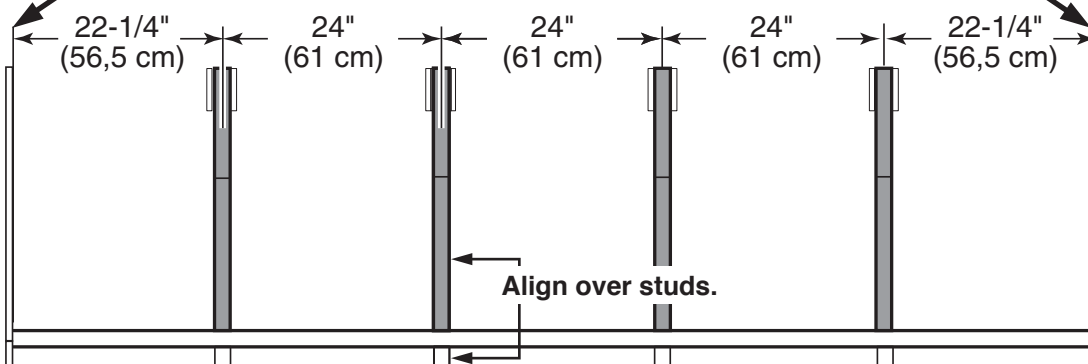

Maintain the measurements between rafters.



# TRIM

## PARTS REQUIRED:

x2 **DN**  
1 x 3 x 23-1/4" (2,5 x 7,6 x 59 cm)

x2 **BS**  
1 x 3 x 95-1/2" (2,5 x 7,6 x 242,5 cm)

2" (5 cm) x28



✓ **BEGIN**

**1** Attach fascia trim flush to bottom of soffit (**Fig. A**) and endcaps at ends of rafters (**Fig. B, C**) using 2" (5 cm) nails as shown.

**2** Repeat steps to attach fascia trim on both sides.



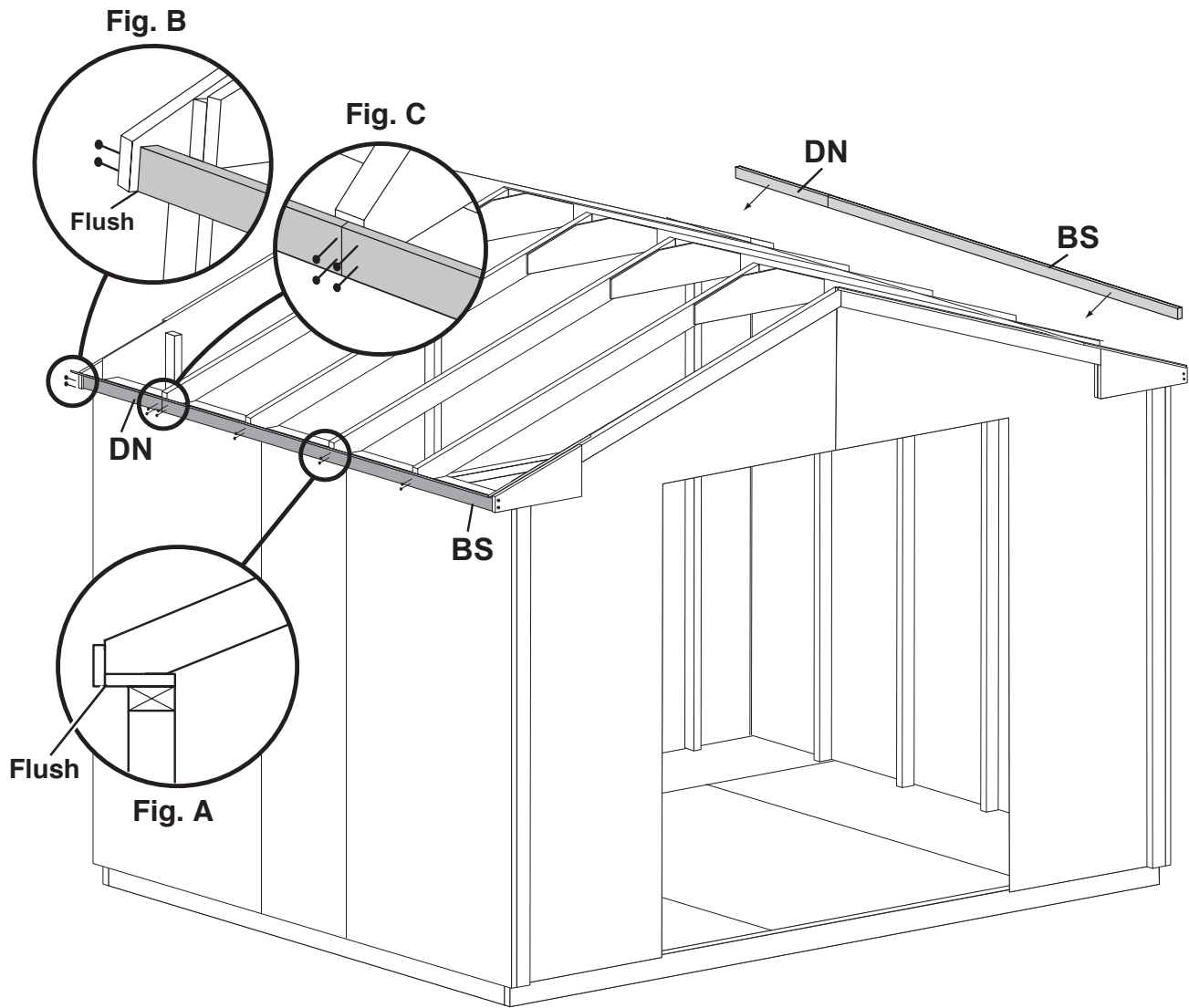
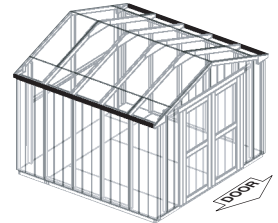

◆ **FINISH**

**3** You have attached your fascia trim.

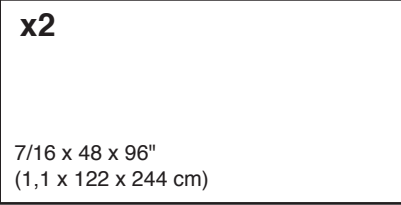

# ROOF PANELS

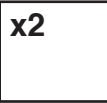
## PARTS REQUIRED:

<b>x2</b>	<b>x2</b>
	
7/16 x 48 x 96" (1,1 x 122 x 244 cm)	7/16 x 19 x 96" (1,1 x 48 x 244 cm)
<b>x2</b>	<b>x2</b>
	
7/16 x 23-7/8 x 19" (1,1 x 61 x 48 cm)	7/16 x 23-7/8 x 48" (1,1 x 61 x 122 cm)

**GAA**  
**3/4"**  
**GAUGE**  
**BLOCK**

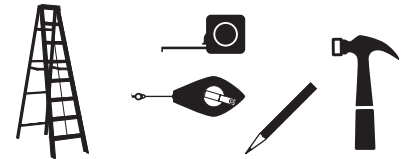
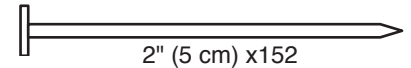

**!** Roof panels may cause serious injury until securely fastened.

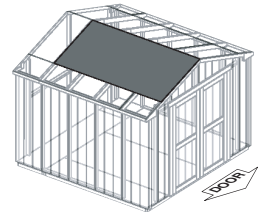

You must square the roof by attaching one panel first. You will use the panels' long edge as a lever to bring your roof into square. Commonly known as "racking".

### ✓ BEGIN

- 1 Attach the 48 x 96" panel with the rough side up (painted-grid lines side) with a 3/4" measurement on the rafter (Fig A) and the panel flush at the peak (Fig. B).

Secure panel with two 2" nails in the corners.

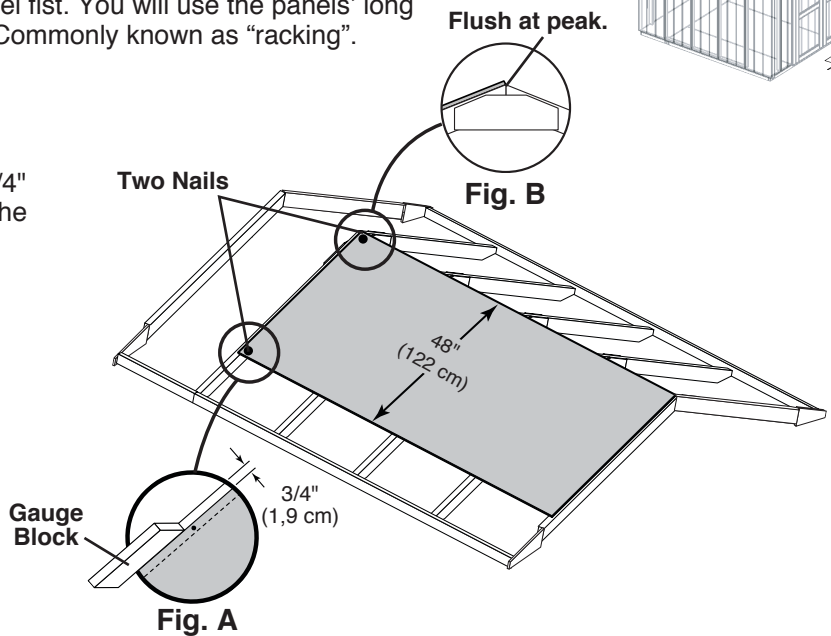

- 2 Move to the opposite end. Using the long edge of the panel as a lever move the panel side-to-side until the top corner is flush to the peak (Fig. C) and there is 1/4" measurement to the gable trim (Fig. D).

You may need to move your backwall to get the 1/4" measurement. Secure panel with two 2" nails in the corners.

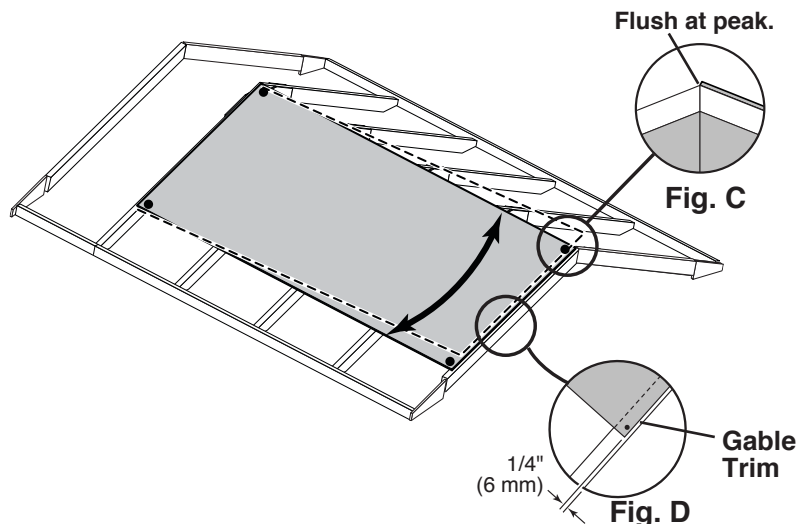

# ROOF PANELS

## PARTS REQUIRED:

GAA

3/4"

GAUGE BLOCK

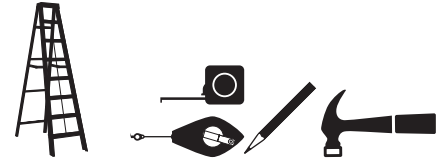

- 3** Keep spacing between the center of the rafters at the lower edge of the panel and secure with one 2" nail into each rafter (**Fig. E**).

Move to the top of the panel and keep spacing between the center of the rafters. Secure with one 2" nail into each rafter (**Fig. E**).

Nail the roof panel using 2" nails 6" apart on edges and 12" apart inside panel.

Attach the second 23-7/8 x 48" upper roof panel flush to first panel, flush at peak and with the 1/4" measurement (**Fig. F, G**).

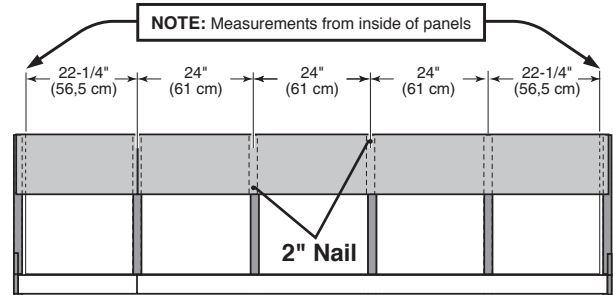
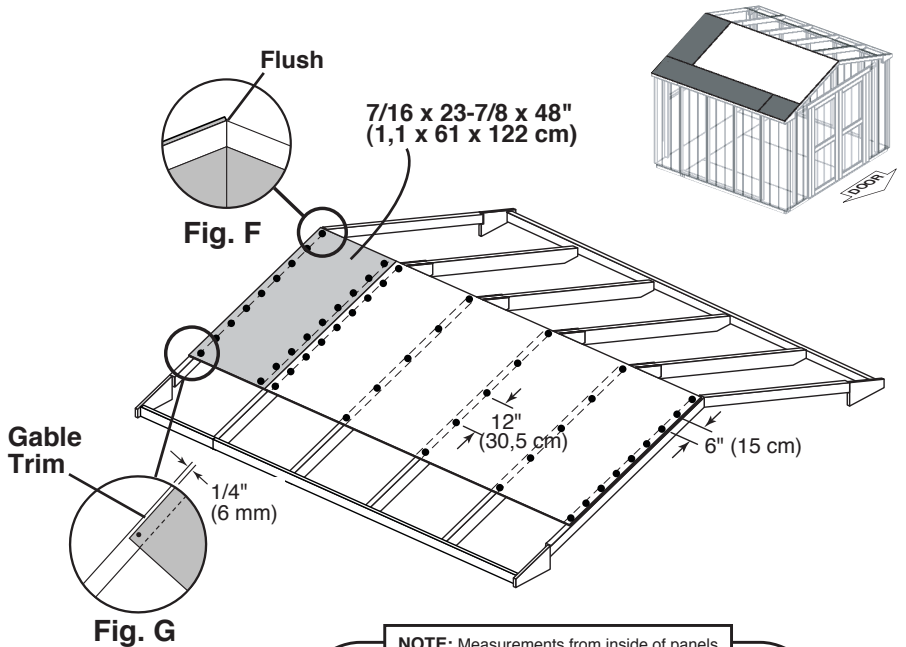
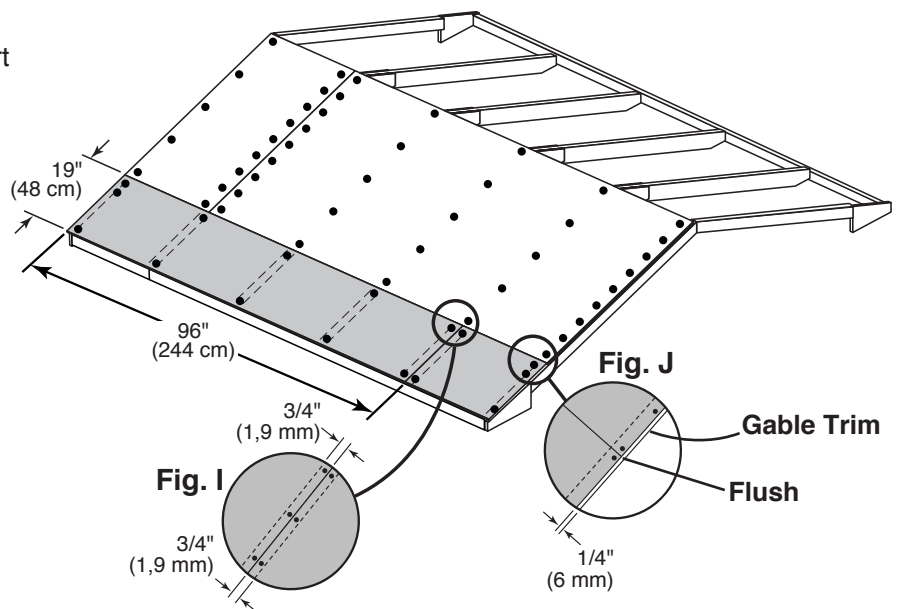
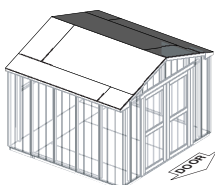

**Fig. E**

- 4** Attach the lower roof panels flush to the upper panels (**Fig. J**) and 3/4" on rafter (**Fig. I**) and with a 1/4" measurement at the gable trim (**Fig. J**).

Nail the roof panel using 2" nails 6" apart on edges and 12" apart inside panel.

Repeat process to attach roof panels on the opposite side.



# DOORS

## PARTS REQUIRED:

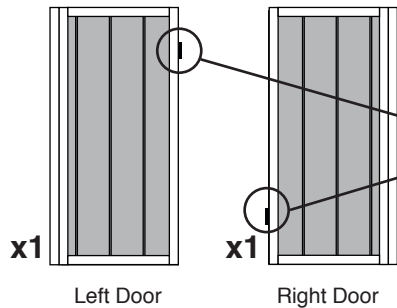

x1 **OO**  
1-1/4 x 2-1/2 x 69" (3,2 x 7,6 x 175,3 cm)

1-1/4" (3 cm) x2

2" (5 cm) x2

3" (7,6 cm) x4

**HINT:**  
Look for 3/8" SPACER  
attached to doors.

x1 **ZJ**  
5/8 x 3 x 72" (1,6 x 7,6 x 183 cm)



### ✓ BEGIN

**1** Orient parts as shown on flat surface. **⚠ 3/8" offset is to top. Look for red (right) and green (left) on hinge board.**

**2** Attach temporary support **OO** with 3" screws in middle and at ends. Tighten securely.

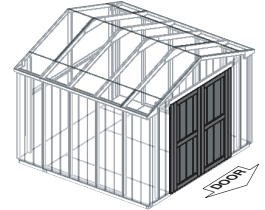

Attach temporary support **ZJ** at bottom with 1-1/4" screws in middle and 2" screws at ends. Tighten securely.

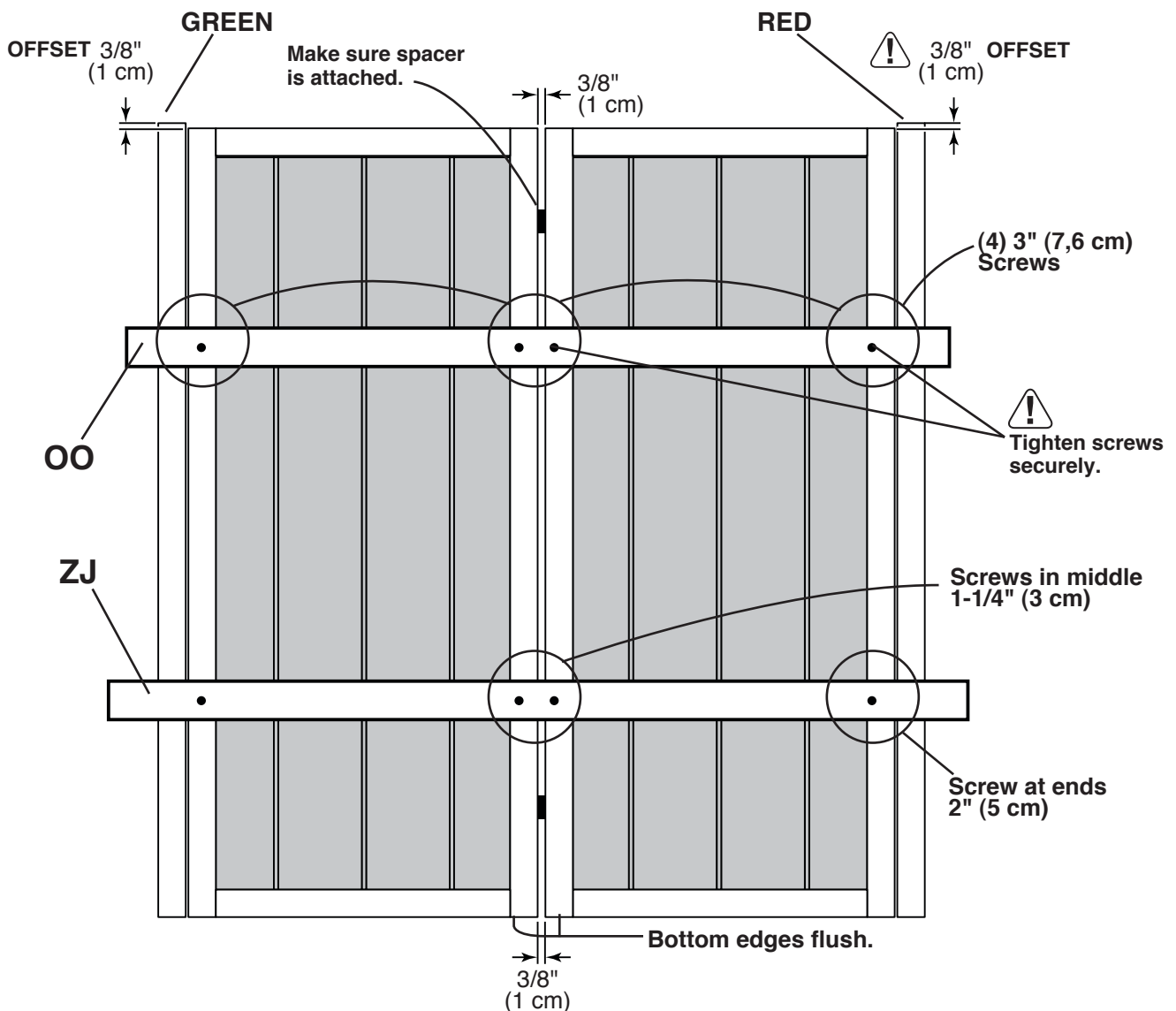

# DOORS

## PARTS REQUIRED:

x1    
 1-1/4 x 2-1/2 x 69" (3,2 x 7,6 x 175,3 cm)

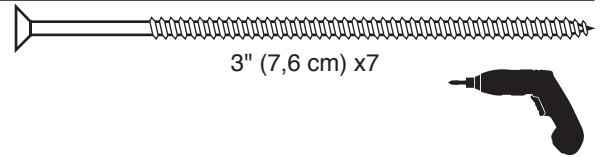

- 3** Attach temporary support **OO** as a ledger board flush under wall panels for doors to rest on, using three 3" screws (**Fig. A**).

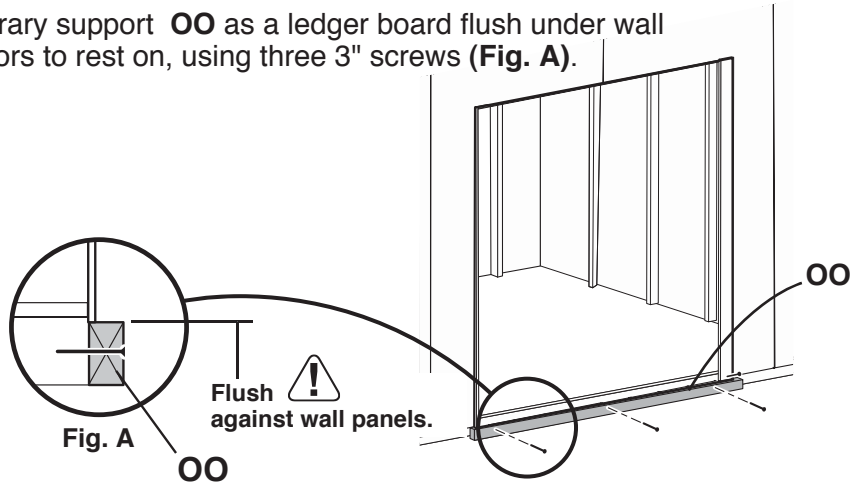

- 4** Center doors on right edge of groove as shown (**Fig. B**). 

 Check ledger board is still flush under panels.

- 5** Screw hinge boards into wall supports and floor using four 3" screws as shown.   
  Make sure screws go into framing and floor (**Fig. C, D**).

- 6** Remove temporary supports and check doors open properly.



- 7** You have finished installing your doors.

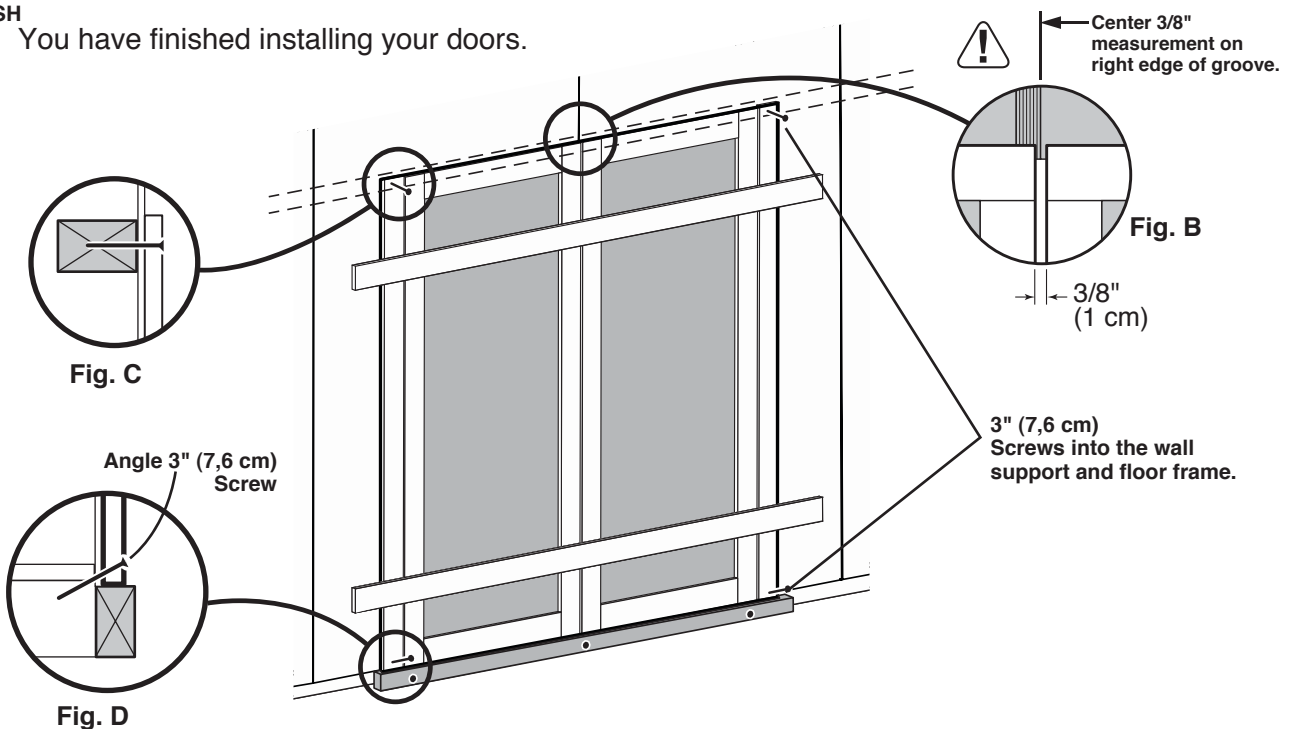

# DOOR

## PARTS REQUIRED:

x1 **ZJ**  
5/8 x 3 x 72" (1,6 x 7,6 x 183 cm)

x2 **AH**  
19/32 x 2-1/2 x 26-5/8" (1,5 x 6,3 x 67,6 cm)

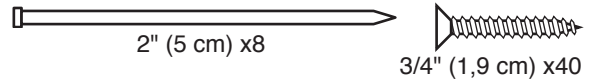

### BEGIN

- 1 Secure hinge boards from inside using 3/4" screws as shown (Fig. A).
- 2 Secure two horizontal door rails **AH** with four 3/4" screws from behind to center of doors as shown.
- 3 Reinforce the door trim using 3/4" screws through door panel into trim (Fig. A). Locate screws as shown in Fig. B. Use two screws at seams.
- 4 Center trim **ZJ** over doors and secure using eight 2" finish nails into framing as shown.

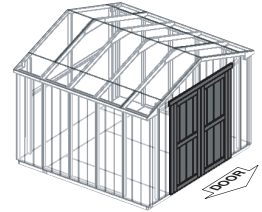

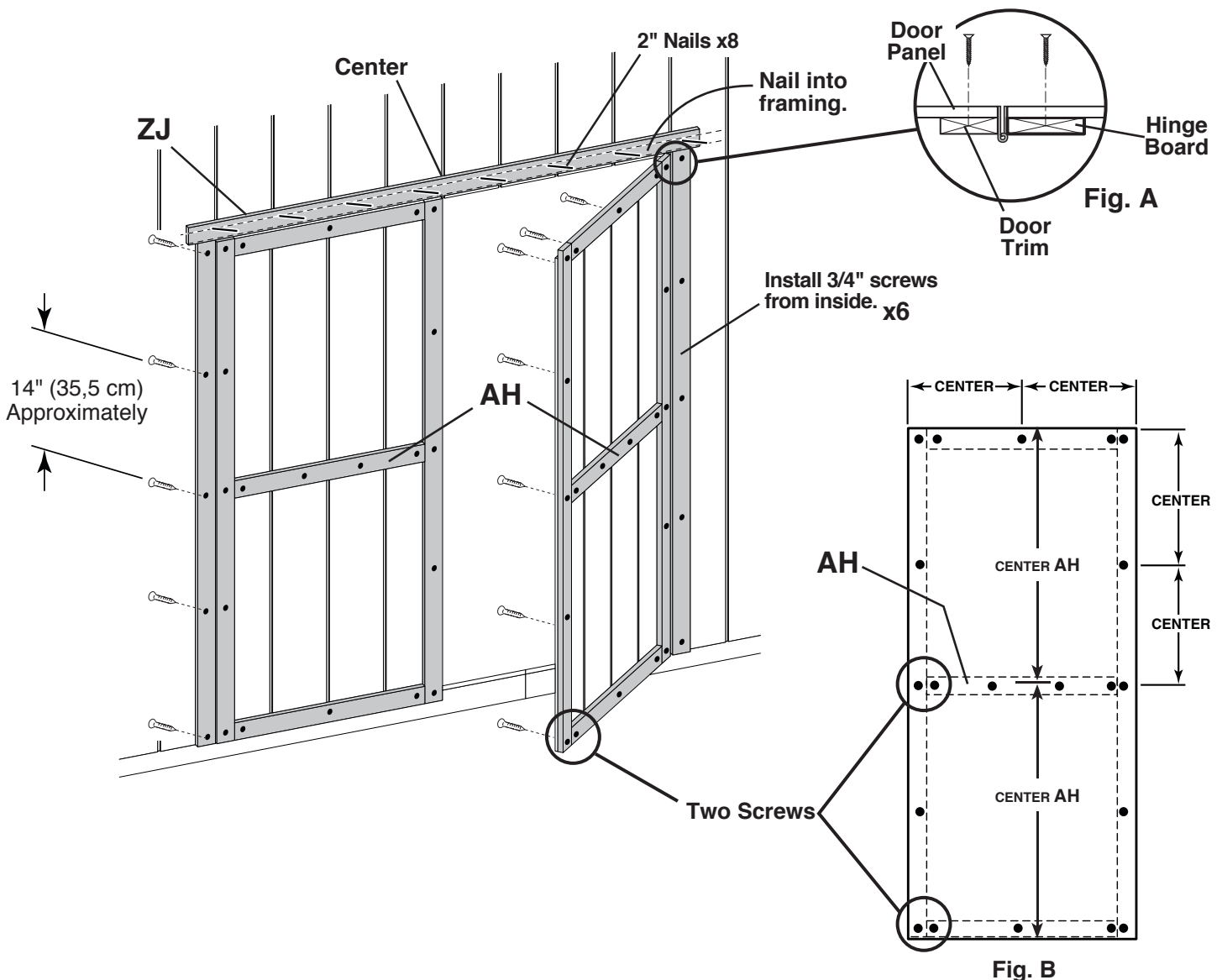

### FINISH

- 5 You have finished securing your door and trim.



# DOOR WEATHERSTRIP

## PARTS REQUIRED:

x2    
 1-1/4 x 2-1/2 x 69" (3,2 x 7,6 x 175,3 cm)

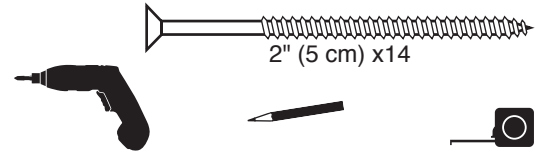

### ✓ BEGIN

- 1 With left door closed, center a weatherstrip **OO** vertically on the left door in the door opening (**Fig. A**). **OO** will offset the left door 1" OUT past the door trim 1" (**Fig. B**).
- 2 Secure **OO** using seven 3" screws through outside trim into **OO** (**Fig. B**)
- 3 On right door center **OO** vertically in door opening (**Fig. A**). **OO** will offset the right door 1" IN from the door trim (**Fig. C**).
- 4 Secure **OO** using seven 3" screws through outside trim into **OO** (**Fig. C**).

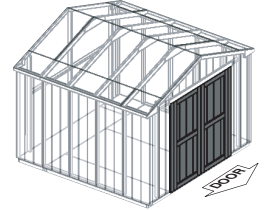

### FINISH

- 5 You have finished installing your door weatherstrips.

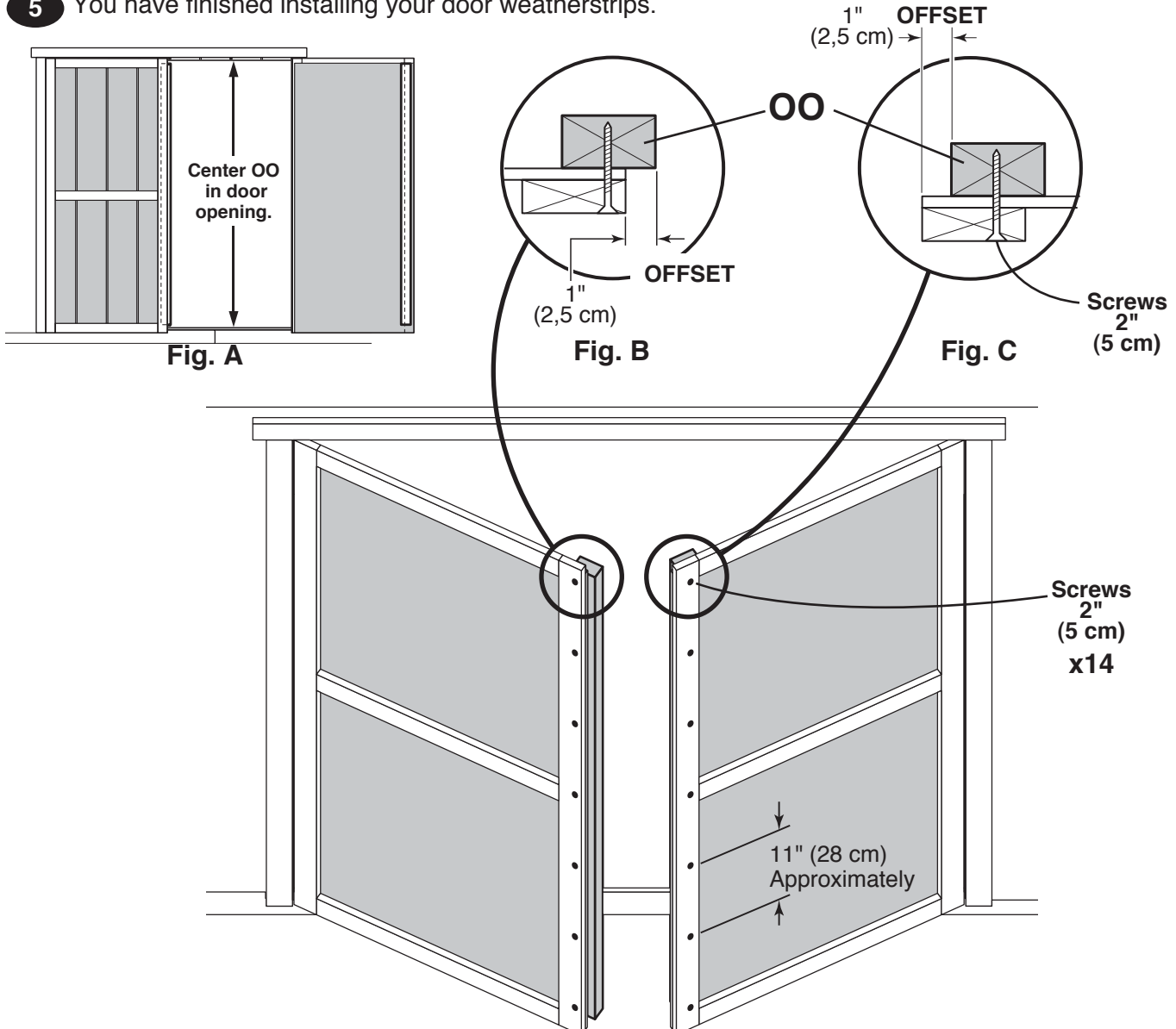

# DOOR HARDWARE

## PARTS REQUIRED:

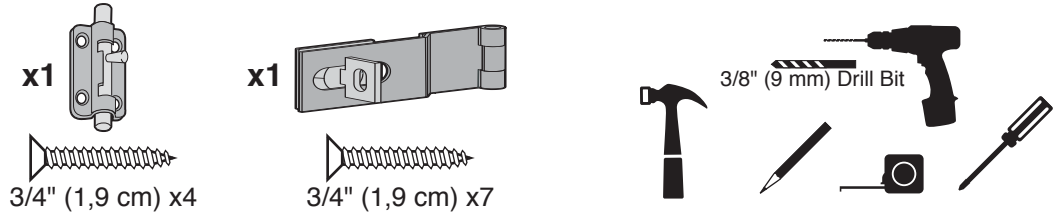

### ✓ BEGIN

- 1 Mount barrel bolt flush at top of **OO** on left door using 3/4" screws as shown (Fig A).
- 2 With door closed mark hole location for bolt to extend into.  
**HINT:** Extend bolt to leave a mark in wood. Tap bolt with hammer. Drill 3/8" hole deep enough for bolt to slide into.
- 3 Install hasp on right door and latch on left door. Bottom edge of hasp is 35-1/2" (90 cm) up from bottom edge of door trim. Measure and mark locations and install with 3/4" screws as shown (Fig B).

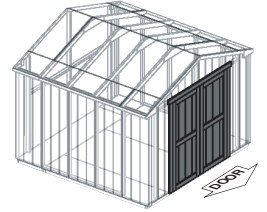

### FINISH

- 4 You have finished mounting your door hardware.

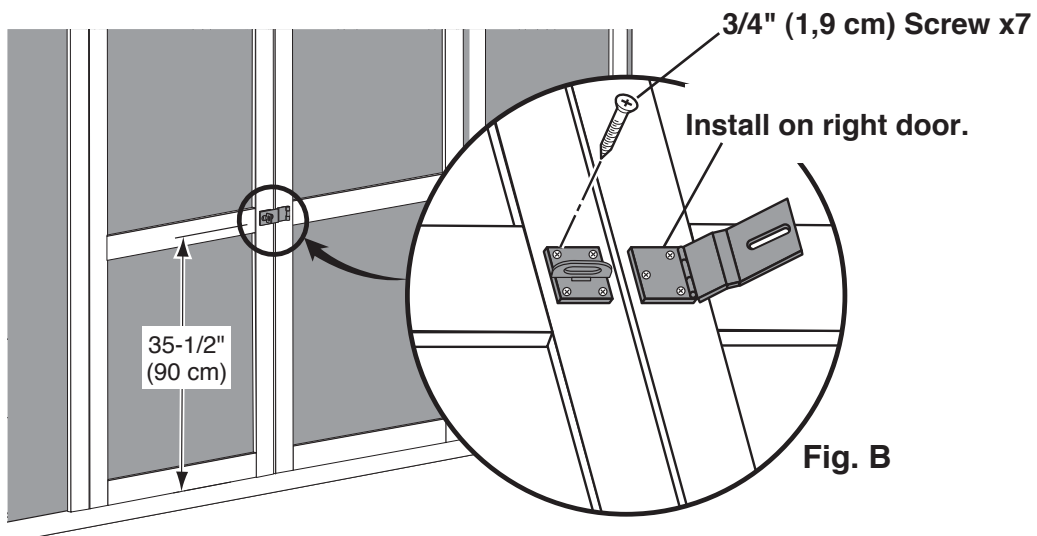
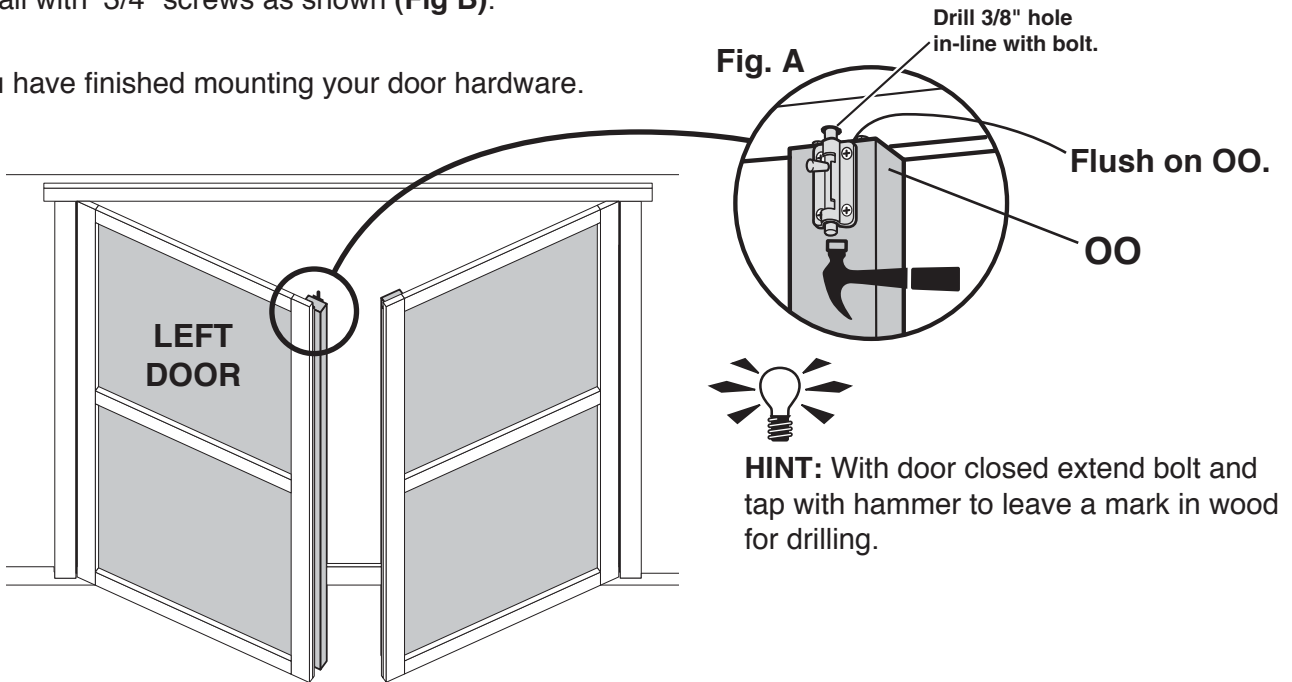



## PAINT & CAULK - NOT INCLUDED -

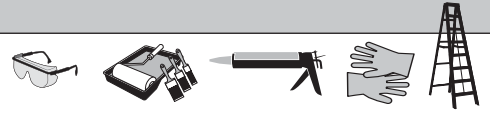

- Use acrylic latex caulk that is paintable. Caulk at all horizontal and vertical seams, between the trim and walls, and all around the door trim.
- Use a high quality exterior acrylic latex paint. When painting your building, there are a few key areas that can be easily overlooked that must be painted:
  - Bottom edge of all siding and trim
  - Inside of doors and all 4 edges

### Note:

Prime all un-primed exterior wood before painting.  
(Follow directions provided by manufacturer.)

## ROOF FELT - NOT INCLUDED -

- Install felt flush to all roof edges overlapping 3". Use minimal amount of roofing nails to hold in place.

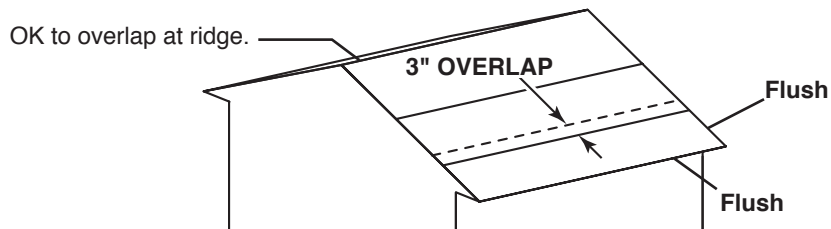

## DRIP EDGE - NOT INCLUDED -



- Install over roof felt on gable side and under roof felt on eave side (**Fig. A**).
- Do not use nails on side of drip edge that hangs over side of building.
- Only nail top of drip edge as shown.

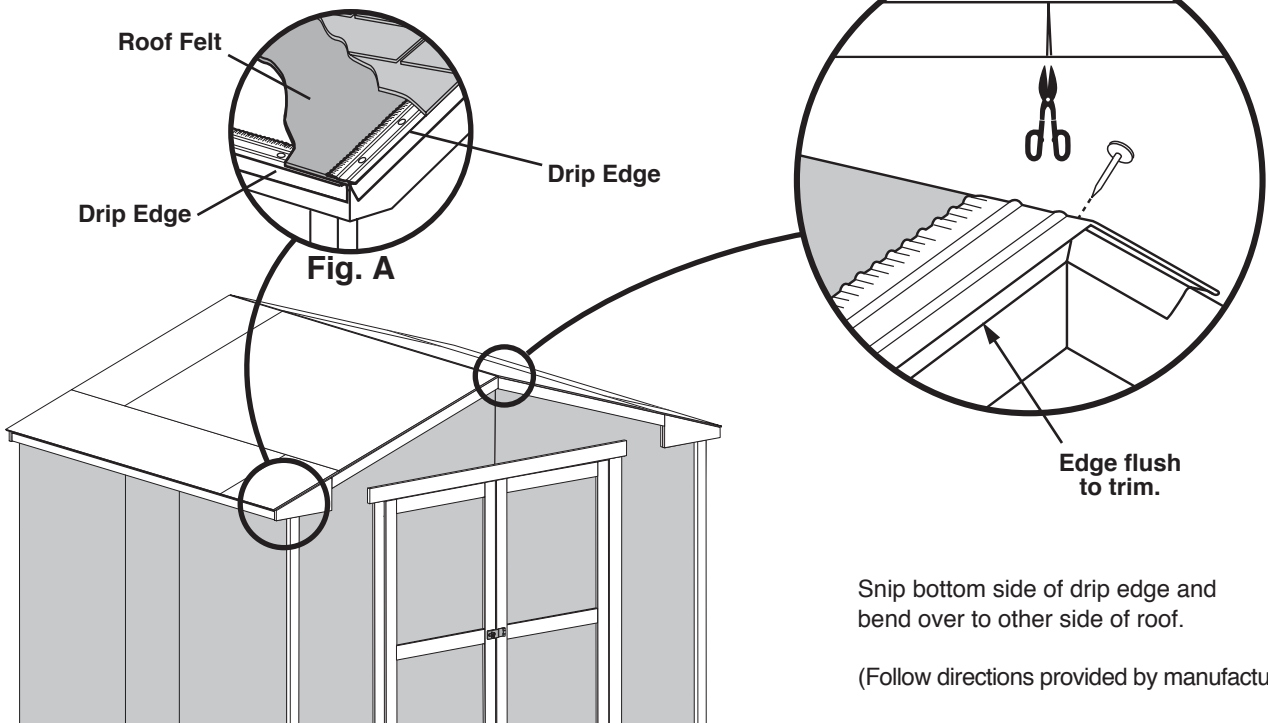

# SHINGLES

- NOT INCLUDED -

• Follow directions provided by manufacturer and these instructions.

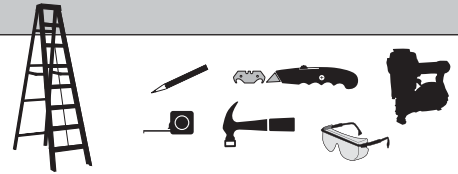

**!** Familiarize yourself with a 3-Tab Shingle.

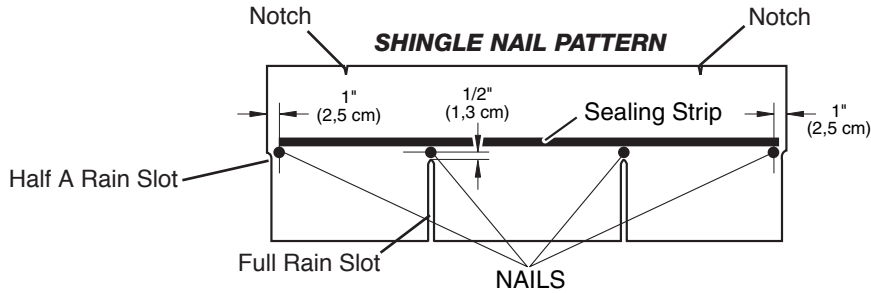

**!** NEVER DRIVE FASTENERS INTO OR ABOVE SEALING STRIPS.

**✓** BEGIN

- 1** Install first starter row upside down and color up with a 1" overhang at back and bottom of roof panel. Use (4) nails per shingle. **Starter row must be straight and level all the way across with lower edge of roof deck.**  
**NOTE:** If you have installed drip edge install shingles flush to drip edge.

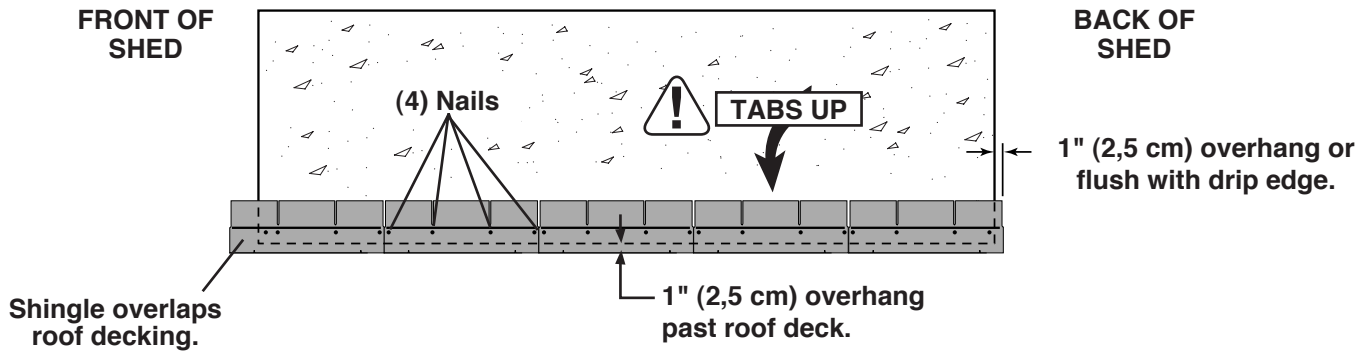

# SHINGLES

continued...

- 2** Beginning at front of shed, install first row of shingles with notch at 1" past roof edge or flush with drip edge.

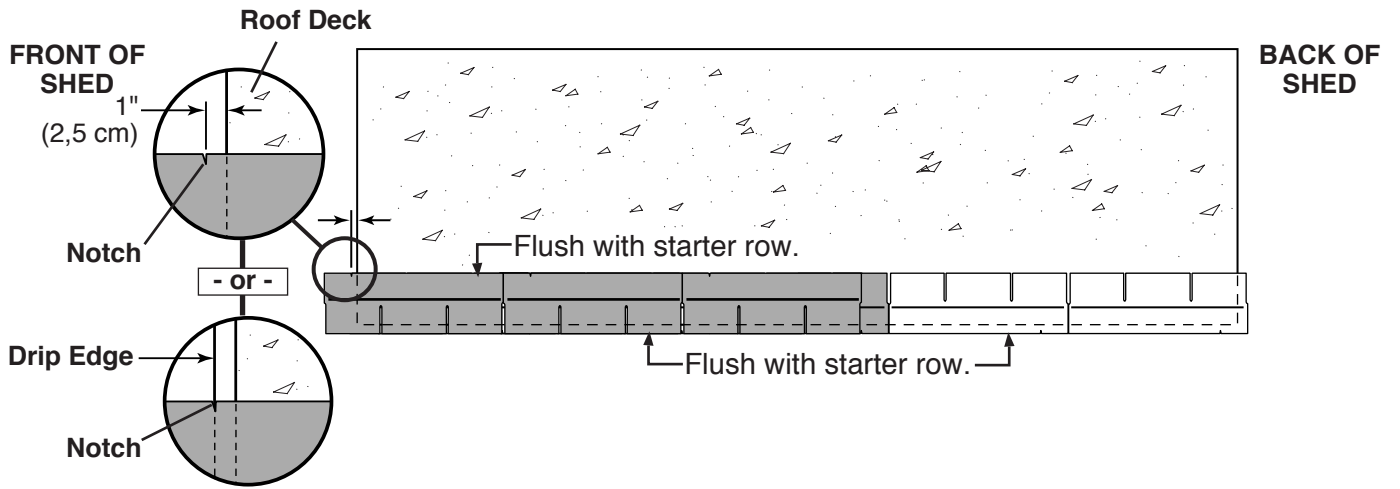

- 3** Install second row of shingles flush at top of first row's rain slots. Ensure 1" overhang or flush to drip edge at front, stagger each row.

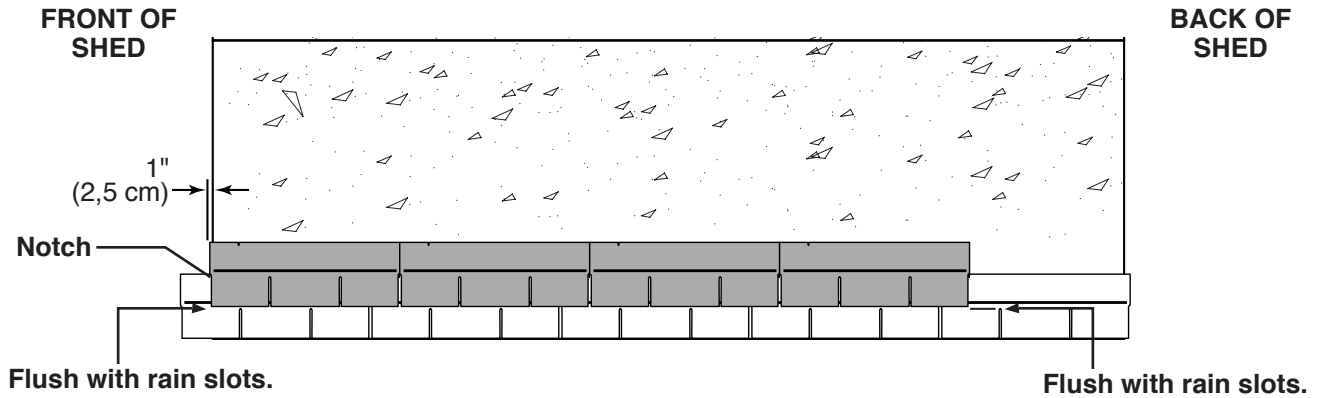

- 4** Continue installing rows of shingles by staggering at front.

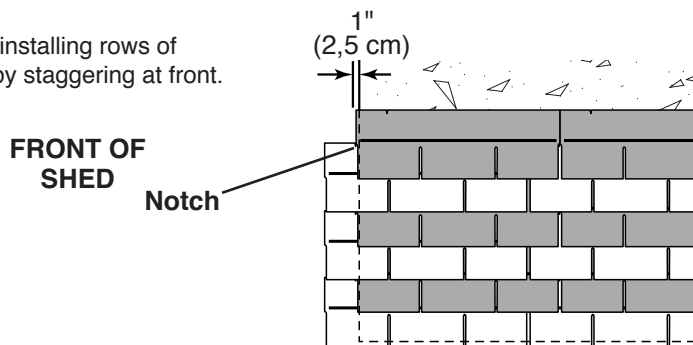

# SHINGLES

continued...

- 5 Continue installing rows of shingles to the peak. At the peak make sure there is a maximum of 5" or less to the rain slot, as shown below. If shingles overlap at ridge cut to peak with a utility knife.

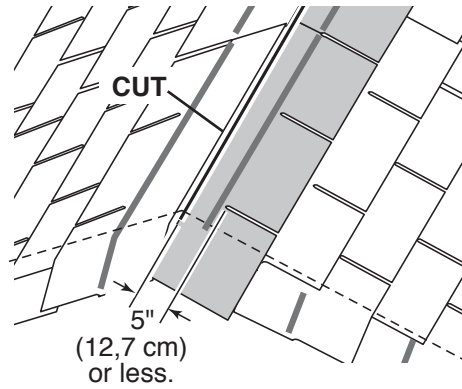
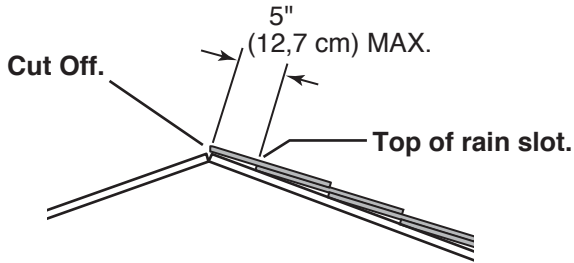

- ! • If more than 5" to rain slot you must install another row of shingles.

- 6 Repeat steps 1 - 5 to shingle the opposite side of your roof. Trim shingles at ridge.

- 7 Once both sides are shingled you need to trim ends. Strike a chalk line 1" from edge.

- 8 Using your shingle hooked blade carefully cut shingles along chalk line.

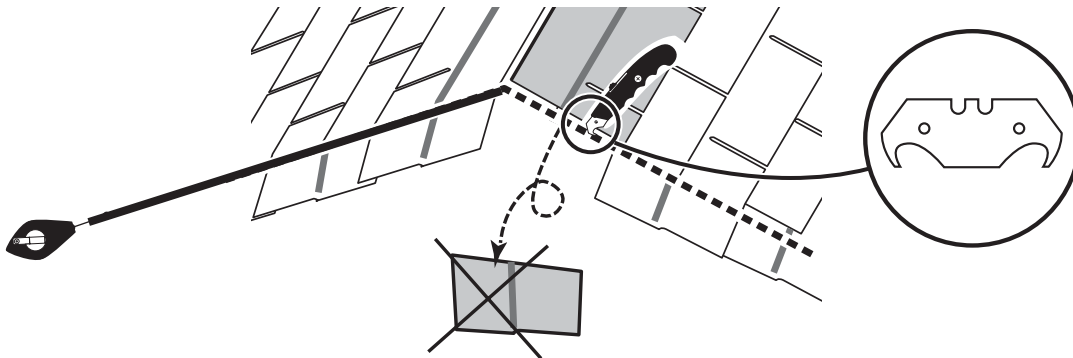

- 9 You have finished shingling your roof. Proceed to capping the ridge.

# SHINGLES - RIDGE CAP

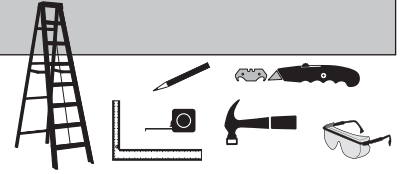

• You will finish off the top of the roof with a ridge cap made from shingles.

**BEGIN**

**1** Cut shingles into THREE pieces. **Hint:** Use cut-off pieces first.

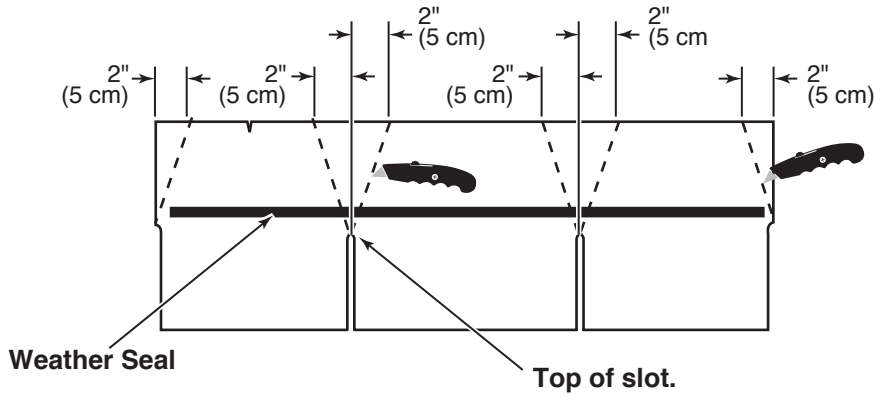

**Score shingle, then snap-off angled cut.**

**Note:** • You will need about 24 - 26 cut pieces.

**24 to 26 Pieces**

**2** Install first ridge cap flush to shingles at front, as shown.

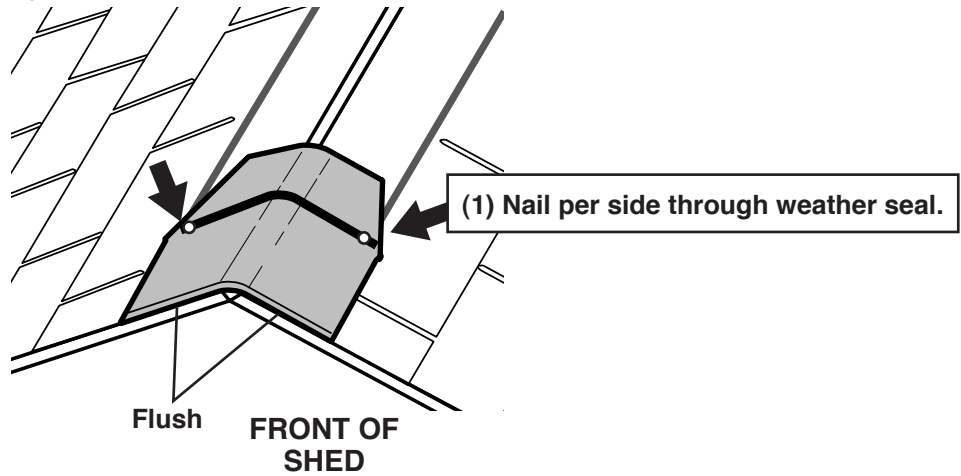

**3** Install second ridge cap 5" back, as shown.

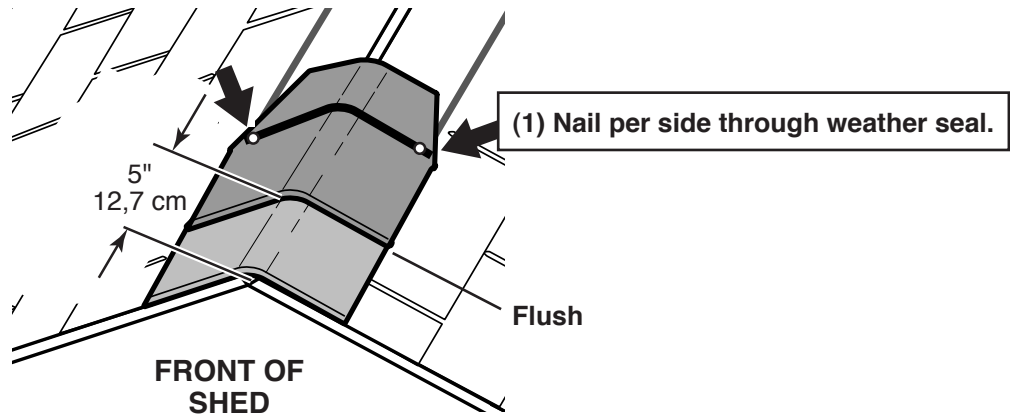

## SHINGLES - RIDGE CAP

continued...

- 4 Continue installing ridge cap to back of roof.

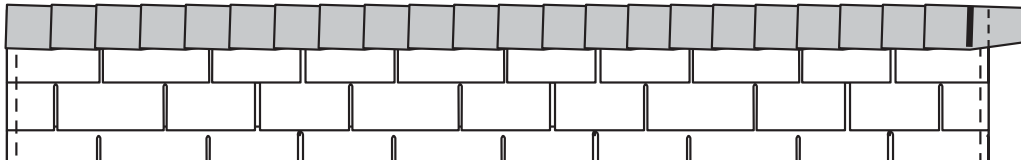

- 5 Make sure there is 4" between the shingle-color and edge of shingles.

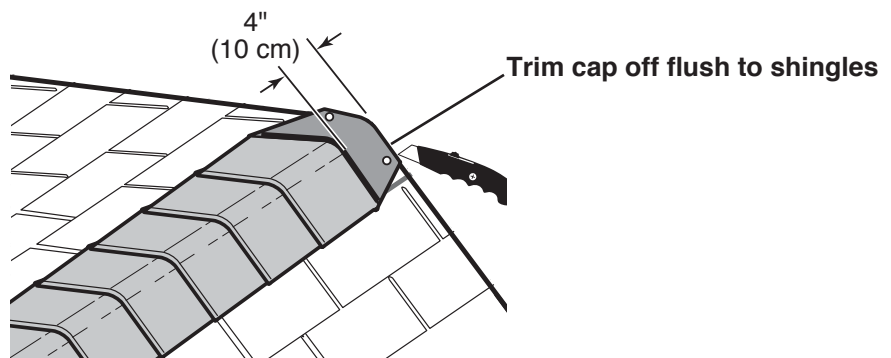

- 6 When you have 4" minimum of shingle color cut one piece to cap your roof.

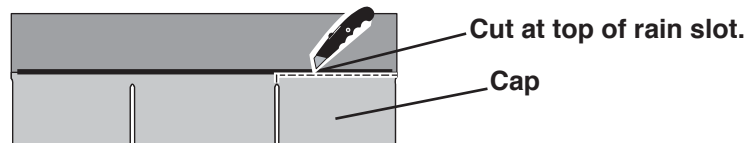

- 7 Install flush to shingles.

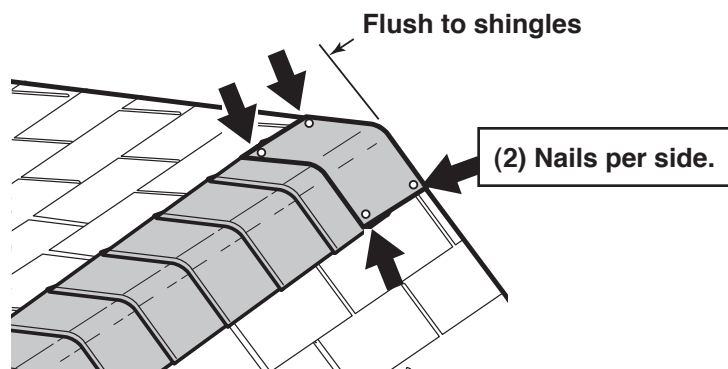

- 8 You have finished your ridge cap.

## WARRANTY

Backyard Storage Solutions, LLC warrants the following:

1. Every product is warranted from defects in workmanship and manufacturing for one year.
2. All hardware and metal components are warranted for two years.
3. Trim is warranted for 10 years.
4. Waferboard siding and sheathing is warranted for two years.
5. SmartSide™ siding is warranted for 10 years on all Marco series buildings and 15 years on all Premier Series buildings.
6. Timber series buildings' siding and trim are warranted for 10 years.
7. Solar Shed windows are warranted for 1 year.
8. Cedar lumber is warranted for 15 years.
9. Cedar doors and Cedar Garden Center are warranted for 10 years.
10. Metal roof is warranted for 25 years.

**Limited Conditional  
Warranty \***

Backyard Storage Solutions, LLC will repair, replace or pay for the affected part. In no event shall Backyard Storage Solutions, LLC pay the cost of labor or installation or any other costs related thereto. All warranties are from date of purchase. If a cash refund is paid on an affected part, it will be prorated from the date of purchase.

## CONDITIONS

The warranty is effective only when:

1. The unit has been erected in accordance with the assembly instructions.
2. The unit has been properly shingled and painted or stained and reasonably and regularly maintained thereafter.
3. The failure occurs when the unit is owned by the original purchaser.
4. Backyard Storage Solutions, LLC has received the warranty registration card within thirty (30) days of purchase and notification of the failure in writing within the warranty period specified above.
5. Backyard Storage Solutions, LLC has had reasonable opportunity during the sixty (60) days following receipt of notification to inspect and verify the failure prior to commencement of any repair work.

## REQUIREMENTS

### Storage Buildings & Playhouses

To validate your warranty, it is necessary to properly maintain your Backyard Storage Solutions, LLC unit; shingle the roof and paint or solid-colored stain the siding using 100% acrylic latex exterior product with a minimum of two (2) coats within thirty (30) days of assembly; caulk above all doors and all horizontal and vertical trim boards; paint and seal all exposed edges, sides and faces of SmartSide™ and waferboard siding to include all exterior walls and all sides and all edges of doors.

### Gazebos, Pergolas & Timber Buildings

To validate your warranty, it is necessary to properly maintain your Backyard Storage Solutions, LLC unit. This includes treating all of the exposed cedar and pine surfaces on your gazebo or timber building with an exterior grade wood preservative, an exterior oil-based semi-transparent stain, an acrylic latex exterior paint or an acrylic latex solid color exterior stain within 30 days of assembly and as needed thereafter to maintain your warranty.

Keep vegetation trimmed away from building and make sure siding panels and trim do not come in contact with masonry or cement. The minimum ground clearance for siding must be one half inch (½ inch) from concrete slab or two and one half inches (2 ½") from the ground when building is erected or constructed on a treated wood floor kit. Water from sprinklers must be kept off unit. In no event will Backyard Storage Solutions, LLC be responsible for any indirect, incidental, consequential or special damages nor for failure(s) that are caused by events, acts or omissions beyond our control including, but not limited to, misuse or improper assembly, improper maintenance (which eventually leads to rot or decay) and acts of God. Backyard Storage Solutions, LLC will not be held responsible for any labor costs incurred to construct your unit. This warranty gives you certain specific rights that vary from state to state.

## CLAIM PROCEDURE

To make a claim under this warranty, you can either call 1-888-827-9056 or prepare a letter. Please have ready the information below when you call or include the information when writing:

1. The model and size of the product.
2. A list of the part(s) for which the claim is made.
3. Proof of purchase of the Backyard Storage Solutions, LLC item, as shown on the original invoice.
4. Run code, as listed on the yellow warranty card enclosed in the product package.

Mail the above information to:

Backyard Storage Solutions, LLC  
Attn: Customer Service  
1000 Ternes  
Monroe, MI 48162

**\*WARRANTY TERMS MAY VARY OUTSIDE THE U.S.A.**

**IMPORTANT: This is your warranty certificate.**

**Please complete and mail your warranty card to properly validate your warranty.**