



Thank you for selecting JELD-WEN products. Attached are JELD-WEN's recommended installation instructions for exterior steel, fiberglass, and wood door slabs. Read these instructions thoroughly before beginning. They are designed to work in most existing applications however; existing conditions may require changes to these instructions. If changes are needed, they are made at the installer's risk. For installations other than indicated in these instructions, contact a building professional.

Not all exterior door types may be installed into every wall condition in all areas. See our Appropriate Protection document for overhang requirements at www.jeld-wen.com. Consult your local building code official for applicable building codes and regulations. Local building code requirements supersede recommended installation instructions.

Note to Installer: Provide a copy of these instructions to the building owner. By installing this product, you acknowledge the terms and conditions of the limited warranty as part of the terms of the sale.

GLOSSARY

Head Jamb

The horizontal jamb across the top of the opening.

Hinge

Metal component that attaches the slab to the jamb and allows the slab to swing open and closed.

Hinge Jamb

The side jamb the hinges are mounted in.

Hinge Leaves

The flat parts of the hinge that mount to the jamb and slab.

Hinge Pin

Pin that holds the hinge leaves together and allows them to pivot.

Hinge Route

Mortise in the jamb and slab the same profile as the corresponding hinge leaf.

Jamb

Framework attached to the structure that the slab is mounted to, or hung in.

Panel

Component of the slab filling the spaces between the stiles and rails.

Pilot Hole

A drilled hole that is no larger than the body of the screw (minus the threads).

Rail

Horizontal members of the door slab.

Slab

The operating part of the door assembly that swings open and closed inside a frame.

Stile

Vertical members of the door slab.

Stop

Component fixed to the inside the jamb that the slab closes against.

Strike Jamb

The side jamb that contains the latch strike to hold the slab closed.

Please allow sufficient time to properly prepare the opening, install the slab, and ensure its proper operation.

Estimated Install Time for New Construction	<input type="checkbox"/> First Time: 1½ hr	
	<input type="checkbox"/> Experienced: ¾ hr	
	<input type="checkbox"/> Professional: ½ hr	

SAFETY AND HANDLING

SAFETY

- Read and fully understand ALL manufacturers' instructions before beginning.
- Do not work alone. Two or more people are recommended. Use safe lifting techniques.
- Use caution when handling glass. Broken or cracked glass can cause serious injury.
- Wear protective gear (e.g. safety glasses, gloves, ear protection, etc.).
- Operate hand/power tools safely and follow manufacturer's operating instructions.

IF INJURY OCCURS, IMMEDIATELY SEEK MEDICAL ATTENTION!

MATERIALS AND SLAB HANDLING

- Allow doors to acclimate for at least 24 hours to local conditions before installation or finishing.
- Store slabs in a dry, well-ventilated protected area off of the floor. Buildings where humidity and temperature are controlled provide the best storage facilities (recommended conditions 30%-50% Relative Humidity and 50°F to 90°F)
- Protect from exposure to direct sunlight during storage.
- Handle doors with clean hands or while wearing clean gloves.
- Lift and carry doors to move, do not drag across one another.
- Heed material manufacturers' handling and application instructions.
- Install only into vertical walls and when conditions are dry.

NEEDED MATERIALS AND TOOLS

NEEDED MATERIALS

- Hinges
- Wood screws (minimum 5/8" through hinges; 1 - 2 1/2" through interior hole in the top two hinges into framing)
- Wood putty/spackle
- Lockset and template
- Finishing supplies
- Masking tape (for trimming wood doors only)
- 150-280 grit sandpaper

Note! Follow all material manufacturers' instructions for proper use and compatibility.

NEEDED TOOLS

- Safety glasses
- Screwdrivers
- Pencil
- Chisel or router
- Drill with bits and hole saws
- Tape measure
- Finishing tools (paint brushes, roller, spray equipment, masking tape etc.)
- Circular saw (for trimming wood doors only)
- Level
- Wood plane (for trimming or beveling wood doors only)
- Hammer
- Punch

1 REMOVE PACKAGING AND INSPECT SLAB

- Remove shipping materials such as corner covers, shipping blocks or pads.
- Inspect slab for cosmetic damage, squareness and warp

- Verify it is the correct product (size, color, design, handing etc.)
- If any of the above conditions represent a concern, do not install the slab. Contact the supplier for recommendations.

2 INSPECT EXISTING JAMB

- Existing jamb should be 3/16" wider than the slab and at least 5/8" taller. There should be enough distance between the jamb edge and the stop to accommodate the thickness of the slab.
- Verify the existing jamb is square. The (A) and (B) measurements should be the same. Maximum allowable deviation from square is 1/4".

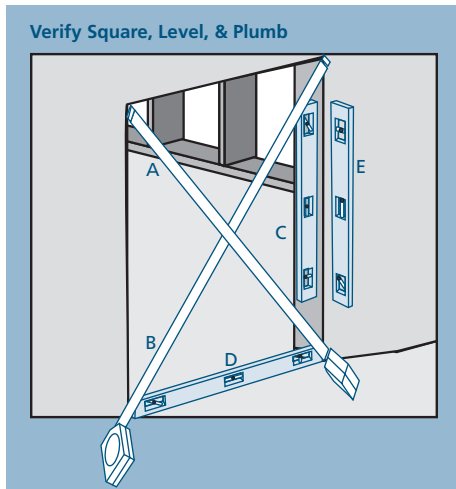

- Verify the existing jamb is level and plumb (C) and (D). The maximum allowable deviation is 1/8".
- The opening floor or sill must be flat and level (not be crowned or sagged) (D).
- The face of the rough opening must be in a single plane (E) with less than 1/8" twist from corner to corner.

Do not install the slab unless the jamb meets the above conditions. Professional assistance may be necessary to correct any problems before installation.

3 INSTALL SLAB

IMPORTANT: The door slab should be finished (painted or stained) on all six sides with an equal number of coats after all routing, trimming, boring and touch-up has been completed and it has been properly fit in the jamb. Failure to finish on all six sides and install into a square, level and plumb condition could result in denial of warranty claims for operational or performance problems. See our finishing document at www.jeld-wen.com for finishing requirements and details.

PREPARE JAMBS AND SLAB

1. Measure the existing frame (not the stop) from the top of the threshold to the bottom of the head and from side to side in several places to verify the slab will fit. The frame should be 3/16" wider than the slab (1/16" clearance on the hinge jamb and 1/8" clearance on the strike jamb) and tall enough (usually 5/8" taller) to allow 1/8" clearance on the head jamb and 1/2" between the bottom of the slab and the top of the threshold.

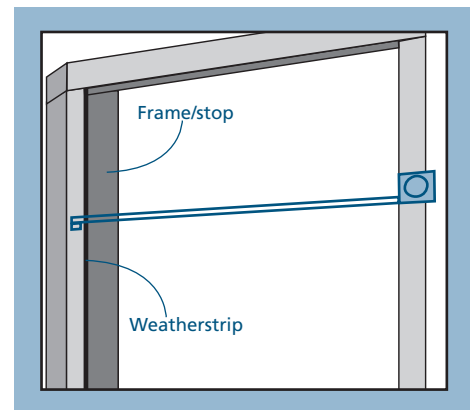

3

INSTALL SLAB - CONTINUED

TRIMMING ALLOWANCE- FOR WOOD DOORS ONLY

1. If necessary to fit the existing jamb, a maximum of 1/4" can be trimmed from each side. For the best appearance, trim an equal amount from opposite sides. To minimize chipping, stick masking tape along the cut line to each face of the slab. Make the cuts with a fine toothed circular saw (height) and wood plane (width). Trimming beveled edges may require re-beveling.
2. The latch stile may have a pre-cut 2° or 3° bevel. This bevel maintains a 1/8" clearance between the jamb and latch edge and improve the fit when the slab is closed. If the latch stile is not beveled, and a bevel is preferred, use a wood plane or fine-toothed saw to cut a bevel so that the slab face that rests against the stop becomes slightly narrower than the opposite face.

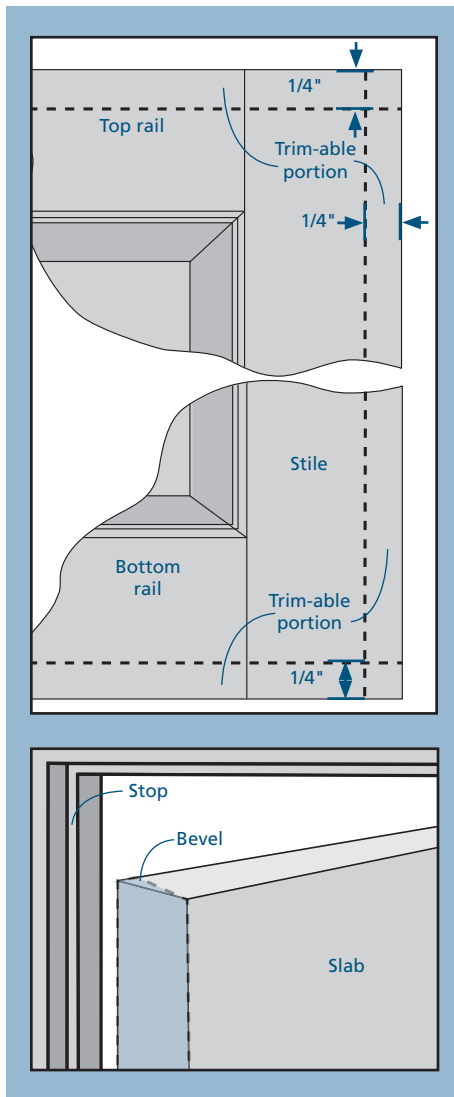

TEST SLAB FIT IN JAMBS

Before installing any hardware, fit the slab in the frame and verify it will fit properly. Looking at the hinge side of the slab when it is closed, there should be 1/16" gap between the slab and hinge jamb and 1/8" between the slab and the head and strike jamb.

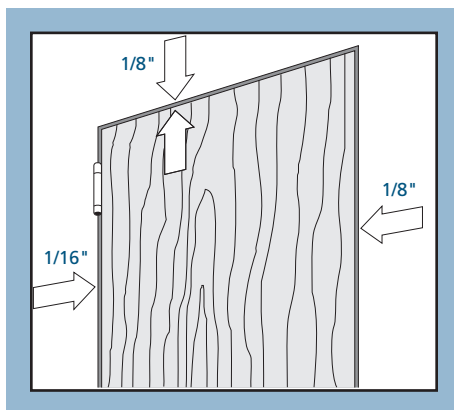

INSTALL HINGES

1. Three hinges are recommended for slabs up to 84" in height and four hinges for slabs over 84" .
2. If re-using existing jambs, verify the existing hinge locations are plumb, or all in a straight line vertically. Position the new hinges in the existing locations and modify the mortises as necessary. Fill and re-drill screw holes if necessary. Match the slab to the jambs using the following instructions.

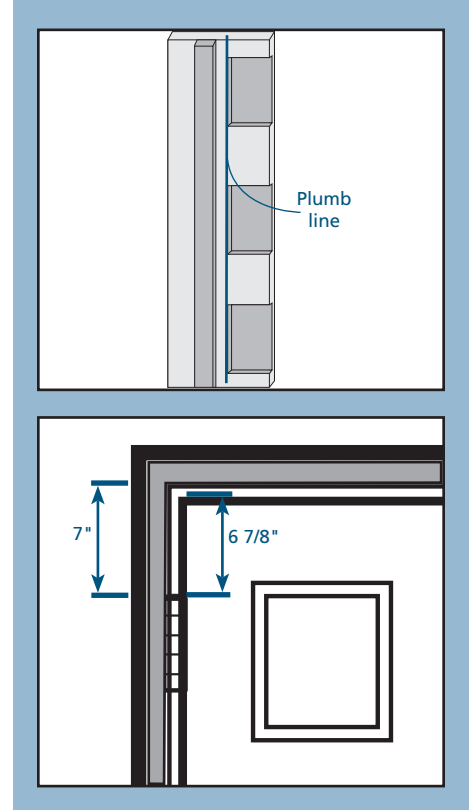

3. If installing new jambs, measure down from the underside of the top of the jamb (not the stop) 7" to position the top of the top hinge. Measure up from the top of the threshold 10" to position the bottom of the bottom hinge. Place the middle hinge halfway in between.
4. When marking the slab for hinges, make sure the measurement from the top of the slab to the top of the hinge route is 1/8" smaller than the distance from the head jamb to the top of the top hinge. This will allow 1/8" gap between the slab and head jamb.

5. When marking the slab, the distance from the inside face to the back of the hinge route should be 1/16" less than the depth of the hinge route on the jamb.

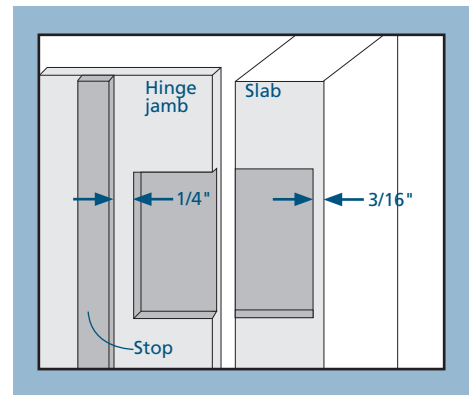

6. Using a template, mark the jambs and slab where the hinges will be mounted. Using a chisel or router, notch the jamb and slab for the outline of the hinge leaves and no deeper than the thickness of the leaves.
7. Using the hinge as a template, mark screw hole locations and drill pilot holes for all screws. If possible, it may be easier to remove the hinge pin to separate the hinge leaves. Use a hammer and a punch to drive the pin from the open end. Install the hinge leaves separately on the jambs and slab. Then, hang the slab in the frame by aligning the hinge leaves and reinstall the hinge pins.

4 COMPLETE INSTALLATION

INSTALL LOCKSET AND FINISH INSTALLATION

1. Most lockset holes will be pre-drilled and the lockset can be installed per the manufacturer's instructions. If the lockset hole is not pre-drilled, follow the instructions in step 2, otherwise, skip to step 3.
2. If installing into existing jambs, bore for the lockset where it will align with the existing strike.

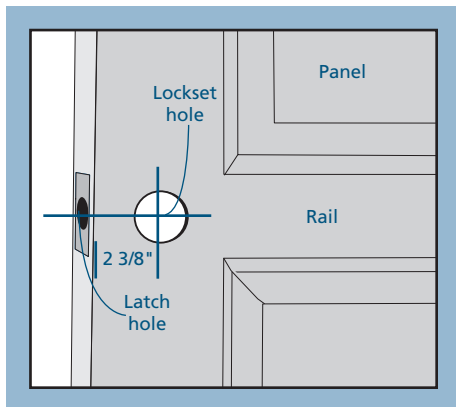

If installing new jambs, the center of the hole for the lockset is usually centered in the rail (horizontal member) across the center of the slab or 35" from the bottom of the slab (not the sweep). Lockset holes should be either 2 3/8" or 2 3/4" on center from the edge, depending on the latch. Using the lockset manufacturer's instructions and template, drill for lockset. Generally, a 2 1/8" diameter hole is needed for the lockset. Drill a 1" latch hole through the edge of the slab into the center of the lock hole to accommodate the latch for the lock. Some latches have a radius (rounded corners) or rectangular face plate that will require the slab edge to be chiseled for fit. Drill pilot holes for attachment screws. Other latches are round (contractor drive-in) and can be tapped into place with a hammer. Install lockset per manufacturer's instructions.

3. Close slab and check for proper operation. Adjust as necessary.
4. Remove hardware and finish all surfaces of the slab if not already done.

Please visit jeld-wen.com for finishing instructions, warranty and care and maintenance information.

Thank you for choosing

