

CHEFMAN.

2-Slice Toaster

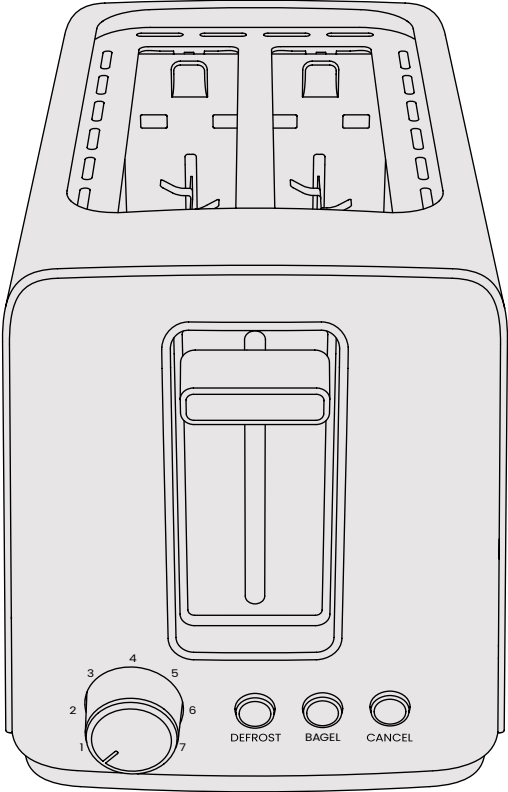

RJ31-SS-V3

Get to Know Your Toaster

1. Toasting slots
2. Lever
3. Shade-setting knob (7 settings)
4. **DEFROST** button
5. **BAGEL** button
6. **CANCEL** button
7. Crumb tray (not shown)

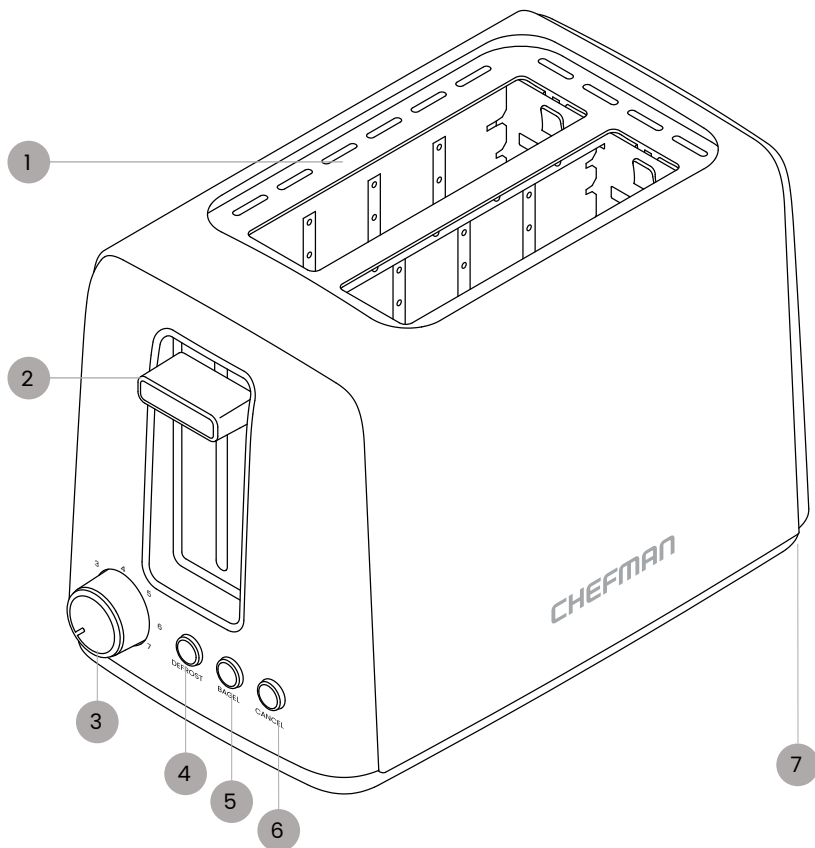

READ ALL INSTRUCTIONS BEFORE USE

For your safety and continued enjoyment of this product, always read the instruction manual before using.

Safety Instructions and Important Safeguards

WARNING: When using electrical appliances, basic safety precautions should always be followed to reduce the risk of fire, electrical shock, and/or injury, including the following:

1. Read all instructions.
2. Do not touch hot surfaces. Use handles or knobs.
3. To protect against electrical shock do not immerse cord or plugs into water or other liquid.
4. Close supervision is necessary when this toaster is used by or near children.
5. Unplug from outlet when not in use and before cleaning. Allow to cool before putting on or taking off parts.
6. Do not operate toaster with a damaged cord or plug, or after the toaster malfunctions or has been damaged in any manner. Contact Chefman® Customer Support for examination, repair, or adjustment.
7. The use of accessory attachments not recommended by Chefman® may cause injuries.
8. Do not use outdoors.
9. Do not let cord hang over edge of table or counter, or touch hot surfaces.
10. Do not place on or near a hot gas or electric burner, or in a heated oven.
11. Always attach plug to toaster first, then plug cord into the wall outlet. To disconnect, turn any control to OFF, then remove plug from wall outlet.
12. Do not use toaster for other than intended use.
13. Oversized foods, metal foil packages, or utensils must not be inserted in toaster as they may involve a risk of fire or electric shock.
14. A fire may occur if toaster is covered or touching flammable material, including curtains, draperies, walls, and the like, when in operation.
15. Do not attempt to dislodge food when toaster is plugged in.

**Save these instructions
For household use only**

Safety Instructions and Important Safeguards

WARNING: This appliance has a polarized plug (one blade is wider than the other). This plug is intended to fit into a polarized outlet only one way. If the plug does not fit fully into the outlet, reverse the plug. If it still does not fit, contact a qualified electrician. **Do NOT** attempt to modify the plug in any way or force it into the outlet. This could result in injury or electrical shock.

Short Cord Instructions

A short power-supply cord is provided to reduce the hazards of entanglement or tripping over a longer cord. Longer detachable power-supply cords or extension cords are available and may be used if care is exercised in their use. If a longer detachable power-supply extension cord is used:

1. The marked electrical rating of the extension cord should be at least as great as the electrical rating of the appliance.
2. The longer cord should be arranged so that it will not drape over the countertop or tabletop where it can be pulled on by children or tripped over.

Safety Instructions and Important Safeguards

Power Cord Safety Tips

1. Never pull or yank on the cord or the appliance.
2. To insert the plug, grasp it firmly and guide it into the outlet.
3. To disconnect the appliance, grasp the plug and remove it from the outlet.
4. Never use the product if the power cord shows signs of abrasion or excessive wear. Contact Chefman® Customer Support for additional guidance and support.
5. Never wrap the cord tightly around the appliance, as this could place undue stress on the cord where it enters the appliance and cause it to fray and break.

DO NOT OPERATE THE APPLIANCE IF THE POWER CORD SHOWS ANY DAMAGE OR IF THE APPLIANCE WORKS INTERMITTENTLY OR STOPS WORKING ENTIRELY.



California Proposition 65:

(Applicable for California Residents only)

WARNING: Cancer and Reproductive Harm
www.P65Warnings.ca.gov

Do not place the appliance on a stovetop or any other heatable surface, even if stovetop is not on. Doing so is a fire hazard.



Before First Use



1. Remove all packing materials and stickers from inside and outside of the toaster.
2. Gently wipe down the exterior with a damp cloth or paper towel.
WARNING: Never immerse the toaster or its plug in water or any other liquid. It is **NOT** dishwasher safe.
3. Read all instructions and follow them carefully.

How to Use Your Toaster

With your 2-Slice Toaster, you can select the toasting mode and shade setting just the way you like it.

1. Ensure the crumb tray is pushed all the way in. Plug in the toaster.
2. Turn the shade-setting knob to the desired setting. The higher the number, the darker and crisper the results.
3. Put your desired food into the toasting slots. **NOTE:** Use only bread products and products designed for toasters, such as toaster pastries.
4. For simple toasting, press the lever all the way down to start.
5. If using the **BAGEL** or **DEFROST** settings (see p. 8 for more information on those functions), push the lever all the way down, and then press one of those buttons. **NOTE:** Each button will illuminate when pressed.

Special Settings and Features

The toaster has three special features available at the push of a button as well as a special safety feature that automatically kicks in if food gets stuck in the toaster.

- **BAGEL:** This setting is designed to toast only one side of the bread. In BAGEL mode, only the outer heating elements heat up. For best results, insert cut bagels or English muffins into the toaster with the cut side facing OUT.
- **DEFROST:** Use for frozen foods like bread and waffles. This button defrosts and toasts simultaneously by increasing the toasting time by 10%.
- **CANCEL:** Use to stop toasting at any time. When the button is pressed, food will automatically pop up.

Anti-Jam Function: Your 2-Slice Toaster is equipped with an anti-jam function. If food gets stuck in the Toaster, the unit will power off.

Toasting Tips

Do not put buttered bread or pastries with frostings into the toaster. This could create a fire hazard.

Never force food into the slots. Food should lower smoothly when the lever is pressed down, or it could get stuck.

Load bagels with cut sides facing out, since only the outer elements within the toasting slots heat up during BAGEL mode.

Lower your shade selection when toasting a single slice. The toaster is designed to heat the entire toasting chamber for two slices. When toasting a single slice, adjust the shade-setting knob lower than you usually would to avoid overbrowning.

Adjust shade selection higher for fresh bread. Moisture in bread slows down toasting. For very fresh or moist bread, adjust the shade-setting knob higher than usual. For drier bread, adjust the knob downward.

Choose thicker slices of gluten-free bread to toast. Store-bought gluten-free breads tend to be thin and crumble easily, making it difficult to evenly toast and keep in one piece. When shopping for gluten-free breads to toast, choose thicker slices with sturdier crusts.

Keep it Clean

Your toaster requires very little maintenance, just the regular removal of crumbs.

1. Unplug the toaster and cool completely.
2. When the toaster is completely cool, wipe the exterior down with a damp cloth or paper towel to remove any fingerprints or smudges.
3. Remove and clean the crumb tray periodically to avoid buildup. If the toaster is used frequently, the crumb tray should be cleaned at least once a week:
 - Once the toaster is unplugged and fully cool, pull out the crumb tray at the bottom back of the toaster.
 - Use a sponge and warm, soapy water to wash. The crumb tray is NOT dishwasher safe.
 - Dry the crumb tray completely.
 - Be sure to push the crumb tray all the way back inside the bottom of the toaster before next use.

Terms and Conditions

Limited Warranty

RJ Brands, LLC d/b/a Chefman® offers a limited 1-year Warranty (the “Warranty”) available on sales through authorized distributors and retailers only. Please note that this Warranty becomes valid from the date of initial retail purchase and that the Warranty is non-transferable and applies only to the original purchaser.

This Warranty is void without proof of purchase within the United States and Canada. Please be aware that this Warranty supersedes all other warranties and constitutes the entire agreement between the consumer and Chefman®. Any changes to the Terms and Conditions of this Warranty must be in writing, signed by a representative of Chefman®. No other party has the right or ability to alter or change the Terms and Conditions of this Warranty.

We may ask you to please submit, via email, photos and/or video of the issue you are experiencing. This is to help us better assess the matter and possibly offer a quick fix. Photos and/or video may also be required to determine Warranty eligibility.

We encourage you to register your product. Registering can make the Warranty process easier and can keep you informed of any updates or recalls on your product. To register, follow the directions on the Chefman® Warranty Registration page in the Chefman® User Guide. Please retain your proof of purchase even after registering. In the event that you do not have proof of your purchase date, we may declare your Warranty void or we may, at our sole discretion, apply the date of manufacture as the purchase date for purposes of this Warranty.

What the Warranty Covers

- **Manufacturer Defects** - Chefman® products are warranted against defects in material and workmanship, under normal household use, for a period of 1 year from the date of purchase when used in accordance with the directions listed in the Chefman® User Guide. If your product does not work as it should, please contact Customer Support at support@chefman.com so that we may assist you.

This Warranty Does Not Cover

- **Misuse**
Damage that occurs from neglectful or improper use of products, including, but not limited to, damage that occurs as a result of usage with incompatible voltage, regardless of whether the product was used with a converter or adapter. See Safety Instructions in the Chefman® User Guide for information on proper use of product;
- **Poor Maintenance**
General lack of proper care. We encourage you to take care of your Chefman® products so that you may continue to enjoy them. Please see Cleaning and Maintenance directions in the Chefman® User Guide for information on proper maintenance;
- **Commercial Use**
Damage that occurs from commercial use;
- **Normal Wear and Tear**
Damage or degradation expected to occur due to normal use over time;
- **Altered Products**
Damage that occurs from alterations or modifications by any entity other than Chefman® such as the removal of the rating label affixed to the product;
- **Catastrophic Events**
Damage that occurs from fire, floods, or natural disasters; or
- **Loss of Interest**
Claims of loss of interest or enjoyment.

For product information, please visit us at Chefman.com.

EXCEPT WHERE SUCH LIABILITY IS REQUIRED BY LAW, THIS WARRANTY DOES NOT COVER, AND CHEFMAN® SHALL NOT BE LIABLE FOR, INCIDENTAL, INDIRECT, SPECIAL, OR CONSEQUENTIAL DAMAGES, INCLUDING WITHOUT LIMITATION, DAMAGE TO, OR LOSS OF USE OF THE PRODUCT, OR LOST SALES OR PROFITS OR DELAY OR FAILURE TO PERFORM THIS WARRANTY OBLIGATION. THE REMEDIES PROVIDED HEREIN ARE THE EXCLUSIVE REMEDIES UNDER THIS WARRANTY, WHETHER BASED ON CONTRACT, TORT OR OTHERWISE.

Warranty Registration

What do I need to register my product?

- Contact Information
- Model Number (see example below)
- Proof of Purchase (online confirmation, receipt, gift receipt)
- Date Code (see example below)
- Access Code (see example below)

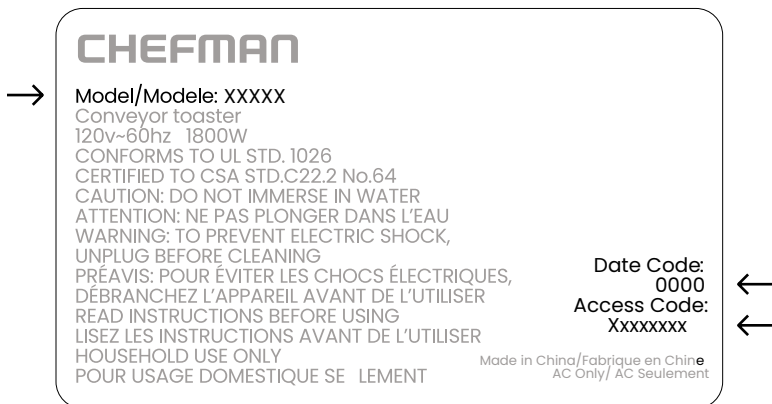

NOTE: Label depicted here is an example.

Please see label on your product for actual model/date code/access code.

How do I register my product?

All you need to do is fill out a simple Chefman® registration form. You can easily access the form in one of the two ways listed below:

- Visit Chefman.com/register.
- Scan the QR code to the right to access site.



CHEFMAN.

2-Slice
Toaster

RJ3ISSV3UG020724

Chefman® is a registered trademark of RJ Brands, LLC.