

# OPERATION

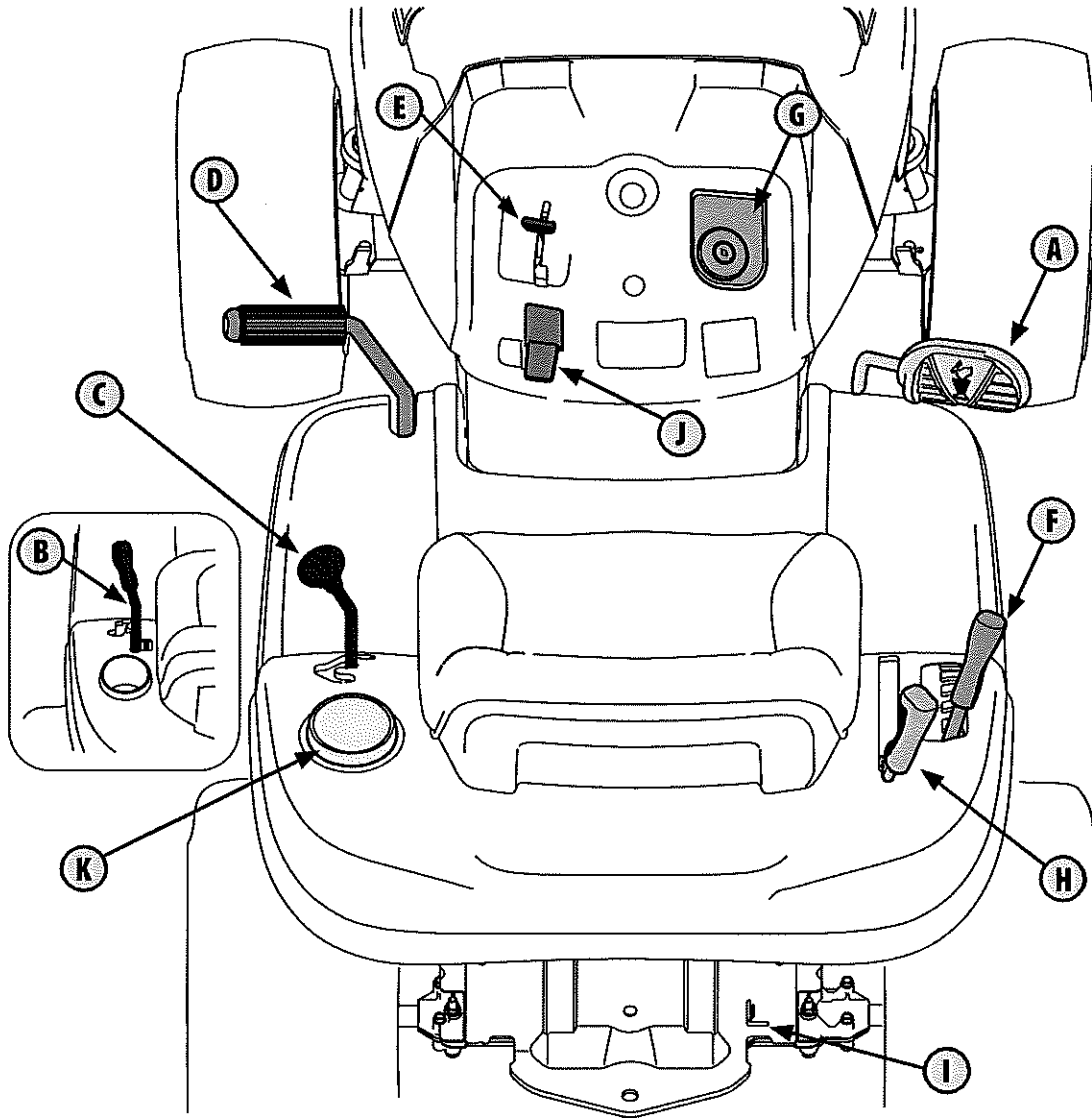

Figure 15

**NOTE:** This Operator's Manual covers several models. Tractor features may vary by model. Not all features in this manual are applicable to all tractor models and the tractor model depicted may differ from yours.

**NOTE:** All references in this manual to the left or right side and front or back of the tractor are from the operating position only. Exceptions, if any, will be specified.

## A. Drive Pedal (Foot Control CVT Models) (If equipped)

Depress the drive pedal forward to allow the tractor to travel. The further forward the pedal is depressed, the faster the tractor will travel. The pedal will return to its original/neutral position when it is not depressed.

## B. Speed Control Lever (Hydrostatic Models)

To drive forward or in reverse, slowly move the Speed Control Lever to the desired "F" forward or "R" reverse speed.

To stop, move the Speed Control Lever to the "N" neutral position.

When mowing, place the Speed Control Lever in the "Cutting Speed" position, or a slower forward speed for the best results.

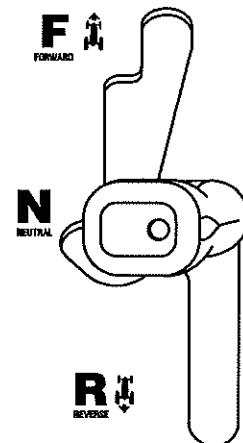

# OPERATION

**NOTE:** Do not use the parking brake pedal to control the ground speed of the tractor while driving. Always use the Speed Control Lever to slow the ground speed of the tractor. Depressing the parking brake pedal with the Speed Control Lever engaged as part of regular operation will result in premature wear of the drive belt.

**IMPORTANT!** Do not attempt to change the direction of travel when the tractor is in motion. Serious damage to the tractor's transmission could result. Always bring the tractor to a complete stop before moving the Speed Control Lever from forward to reverse or vice versa.

## C. Shift Lever (CVT & Foot Control CVT Models)

The shift lever is located on the left side of the fender and has three positions; FORWARD (F), NEUTRAL (N) and REVERSE (R). The brake pedal must be depressed and the tractor must not be in motion when moving the shift lever.

**IMPORTANT!** Never force the shift lever. Doing so may result in serious damage to the tractor's transmission.

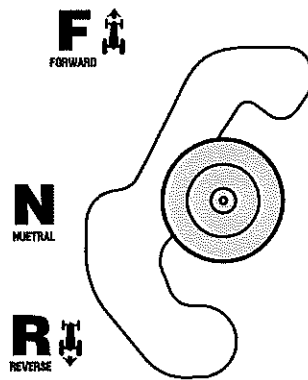

## D. Brake Pedal/Clutch-Brake Pedal

Depress the brake pedal/clutch-brake pedal while the tractor is in use to stop the tractor, to shift (CVT and Foot Control CVT models) and for setting the parking brake.

**NOTE:** The brake pedal/clutch-brake pedal must be fully depressed to start the tractor. Refer to Safety Interlock System for more information.

## E. Throttle or Throttle/Choke Control Lever

Some models have an auto-choke feature. These models do not come with a manual choke function. Push the throttle or throttle/choke control lever forward to increase the engine speed. The tractor is designed to operate with the throttle/choke control lever at full throttle (FAST) when the tractor is being driven and the mower deck is engaged. Pull the throttle/choke control lever rearward to decrease the engine speed. When starting the engine, if equipped with a throttle/choke control lever, push the control lever fully forward into the "CHOKE" position. After starting and warming the engine, move the control lever rearward until you feel it move past the choke detent. Throttle is not meant to control unit speed, throttle should remain in high speed while operating blades.

## F. Deck Lift Lever

The deck lift lever is used to raise and lower the deck. Pull the lever to the left out of the index notch and push downward to lower the deck, or pull upward to raise the deck. When the desired height is attained, move the lift lever to the right until fully engaged in the index notch.

## G. Ignition Switch

### ⚠ WARNING

Never leave a running tractor unattended. Always disengage PTO, set parking brake, stop engine, and remove key to prevent unintended starting.

Refer to Starting the Engine for information on how to start the engine. Refer to Stopping the Engine for instructions on how to stop the engine.

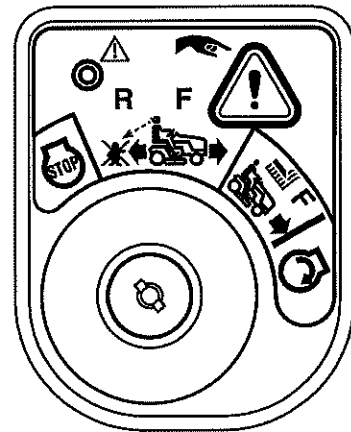

### ⚠ WARNING

Prior to operating the tractor, refer to both Safety Interlock System and Starting the Engine in the Operation section of this manual for detailed instructions regarding the Ignition Switch Module and operating the tractor in REVERSE CAUTION MODE.

## H. PTO (Blade Engage) Lever

The PTO (Blade Engage) Lever engages power to the cutting deck or other (separately available) attachments. See Engaging the PTO (Blade Engage) section for information and instructions on using the PTO.

## I. Transmission Bypass Rod (Hydrostatic Models)

When engaged, the rod opens a bypass within the hydrostatic transmission, which allows the tractor to be pushed short distances by hand. Refer to the Assembly section for instructions on using the bypass feature.

# OPERATION

## J. Park Brake or Park Brake/CVT Drive Control Lever

The Park Brake or Park Brake/CVT Drive Control Lever is used to engage the parking brake and set the drive speed of CVT models. Refer to the Driving the Tractor section of this manual for detailed instructions regarding the parking brake.

**NOTE:** The parking brake must be set if the operator leaves the seat with the engine running or the engine will automatically shut off.

## K. Cup Holder

The cup holder is located to the left of the operator's seat.

## Headlights (Not shown)

On some tractors the lights are ON whenever the Ignition key is rotated out of the STOP position. The lights turn OFF when the ignition key is moved to the STOP position.

On some tractors the lights are ON only while the engine is running. Turning the tractor OFF will turn the lights OFF.

The headlights may flicker briefly as the tractor is turned OFF.

## Operation

### BEFORE OPERATING YOUR TRACTOR

- Before operation, refer to the Maintenance Schedule chart located in this manual for regularly scheduled service items.
- This engine is certified to operate only on clean, fresh, unleaded gasoline. Fill only with clean, fresh, unleaded gasoline with a pump sticker octane rating of 87 or higher.
- Do not use gasoline left over from the previous season, to minimize gum deposits in the fuel system.
- Gasohol (up to 10% ethyl alcohol, 90% unleaded gasoline by volume) is an approved fuel. Other gasoline/alcohol blends are not approved.
- Methyl Tertiary Butyl Ether (MTBE) and unleaded gasoline blends (up to a maximum of 15% MTBE by volume) are approved fuels. Other gasoline/ether blends are not approved.

## Safety Interlock System

### WARNING

Do NOT operate the tractor if the safety interlock system is malfunctioning. This system was designed for your safety and protection.

This tractor is equipped with a safety interlock system for the protection of the operator. If the safety interlock system should ever malfunction, do NOT operate the tractor. Contact an authorized service dealer.

- The safety interlock system prevents the engine from cranking or starting unless the parking brake is engaged or the operator is in the seat and the brake pedal is fully depressed, with the PTO (Blade Engage) Lever in the disengaged (OFF) position.
- The engine will automatically shut OFF if the operator leaves the seat before engaging the parking brake.
- The engine will automatically shut OFF if the operator leaves the tractor's seat with the PTO (Blade Engage) Lever in the ENGAGED (ON) position, regardless of whether the parking brake is engaged.
- With the ignition key in the NORMAL DRIVING MODE position, the engine will automatically shut OFF if the PTO (Blade Engage) Lever is moved into the engaged (ON) position with the speed control in REVERSE (R) position.

### CHECKING THE SAFETY INTERLOCK CIRCUITS

Periodically check the safety interlock circuits to ensure they are working properly. If a safety circuit is not working as designed, contact your authorized service dealer to have the tractor inspected. Do NOT operate the tractor if any safety circuit is not functioning properly. To check the safety circuits, proceed as follows:

1. With the engine off and sitting in the seat, place the PTO (Blade Engage) Lever in the ENGAGED (ON) position. Momentarily turn the ignition switch to the START position; the engine should not crank.
2. With the tractor running, and the parking brake not engaged; lift upward from the operator's seat. The engine should stop.
3. With the parking brake engaged, engage the PTO. Lift upward from the operator's seat; the engine should stop.

## Starting the Engine

### CAUTION

The operator should be sitting in the tractor seat when starting the engine.

1. Insert the ignition key into the ignition switch.
2. Place the PTO (Blade Engage) Lever in the OFF position.
3. Engage the tractor's parking brake.
4. Push the throttle control upward. If equipped with a throttle/choke control lever, push the throttle/choke control lever past the detent, to engage the choke.

**NOTE:** If the engine is warmed up, it may not be necessary to choke the engine.

5. Turn the ignition key clockwise to the START position. After the engine starts, release the key. It will return to the NORMAL MOWING position.

# OPERATION

## ⚠ CAUTION

Do not hold the key in the START position for longer than ten seconds at a time. Doing so may cause damage to your engine's electric starter.

6. For models equipped with a throttle/choke control lever: as the engine warms up, gradually pull the throttle/choke control lever rearward past the choke detent position. Do not use the choke position to enrich the fuel mixture, except as necessary to start the engine.
7. Allow the engine to run for a few minutes at mid-throttle before putting the engine under load.

**NOTE:** When operating the tractor be certain that the throttle lever is always in the FAST position.

## Using Jumper Cables to Start the Engine

## ⚠ WARNING

Batteries contain sulfuric acid and produce explosive gases. Make certain the area is well ventilated, wear gloves and eye protection, and avoid sparks or flames near the battery.

If the battery charge is not sufficient to crank the engine, recharge the battery. If a battery charger is unavailable and the tractor must be started, the aid of a booster battery will be necessary. Connect the booster battery as follows:

1. Connect one end of the red cable to the disabled tractor battery's positive terminal; then connect the other end of that cable to the booster battery's positive terminal.
2. Connect one end of the black cable to the booster battery's negative terminal; then connect the other end of that cable to the frame of the disabled tractor, as far from the battery as possible.
3. Start the disabled tractor following the normal starting instructions previously provided; then disconnect the jumper cables in the exact reverse order of their connection.
4. Have the tractor's electrical system checked and repaired as soon as possible to eliminate the need for jump starting.

## Stopping the Engine

1. If the blades are engaged, place the PTO (Blade Engage) Lever in the OFF position.
2. Engage the tractor parking brake.
3. Place the throttle control to midway between the FAST and SLOW positions.
4. Turn the ignition key counter-clockwise to the STOP position.

## Driving the Tractor

## ⚠ WARNING

Keep all movement of the drive pedal (if equipped), Speed Control Lever (if equipped) and brake pedal slow and smooth. Abrupt movement of the drive control or brake pedal can affect the stability of the tractor and could cause the tractor to flip over, which may result in serious injury or death to the operator.

Sharp turns can affect control of the tractor. ALWAYS slow the tractor before making sharp turns.

Do not leave the seat of the tractor without first placing the PTO (Blade Engage) Lever in the DISENGAGED (OFF) position and engaging the parking brake. If leaving the tractor unattended, also turn the engine off and remove the Ignition key.

## HYDROSTATIC

1. Move the throttle into the FAST position.
2. Depress the brake pedal and move the Park Brake Lever to release the parking brake.
3. To travel FORWARD, slowly move the Speed Control Lever forward until the desired speed is achieved.
4. To travel in REVERSE, check that the area behind is clear then slowly move the Speed Control Lever rearward until the desired speed is achieved.
5. The further forward or rearward that the lever is moved, the faster the tractor will travel.
6. To stop, move the Speed Control Lever to the NEUTRAL (N) position.

## CVT

1. Move the throttle into the FAST position.
2. Depress the clutch-brake pedal and move the Park Brake/CVT Drive Control Lever to the desired speed setting to take the tractor out of PARK and set the drive speed.

**IMPORTANT!** First-time operators should use speed positions 1 or 2. Become completely familiar with the tractor's operation and controls before operating the tractor in higher speed positions.

3. Place the shift lever in either the FORWARD (F) or REVERSE (R) position.

## ⚠ WARNING

Do NOT use the shift lever to change the direction of travel when the tractor is in motion. Always use the clutch-brake pedal to bring the tractor to a complete stop before shifting.

4. Release clutch-brake pedal slowly to put the tractor into motion.

# OPERATION

5. To stop, depress the clutch-brake pedal.

If tractor stalls with speed control in high speed, or if tractor will not operate with Speed Control Lever in a low speed position, proceed as follows:

1. Depress the clutch-brake pedal.
2. Place shift lever in NEUTRAL (N).
3. Restart engine.
4. Place CVT Drive Control Lever in highest speed position.
5. Release clutch-brake pedal fully.
6. Depress clutch-brake pedal.
7. Place CVT Drive Control Lever in desired position.
8. Place shift lever in either FORWARD (F) or REVERSE (R), and follow normal operating procedures.

## FOOT CONTROL CVT

1. Move the throttle into the FAST position.
2. Depress the brake pedal and move the Park Brake/CVT Drive Control Lever out of the PARK position.
3. Place the shift lever in either the FORWARD (F) or REVERSE (R) position.
4. Release clutch-brake pedal fully.
5. Gradually begin to apply pressure to the drive pedal. The further down the pedal is pushed, the faster the tractor will travel in the desired direction based on the position of the shift lever.
6. Stop the tractor by releasing the drive pedal and then depressing the brake pedal.

## Engaging the Parking Brake

**NOTE:** The parking brake must be set if the operator leaves the seat with the engine running or the engine will automatically shut off.

To set the parking brake:

1. Depress the brake pedal (Hydrostatic models) or clutch-brake pedal (CVT and Foot Control CVT models) completely down with your left foot and hold it in that position.
2. Move the Park Brake Lever (Hydrostatic models and Foot Control CVT models) or Park Brake/CVT Drive Control Lever (CVT models) all the way down and into the Park Brake Engaged position.
3. Remove your foot from the brake pedal/clutch-brake pedal.

After completing Step 3, the brake pedal should remain in the down position. If it doesn't, the parking brake is not engaged. Repeat Steps 1-3 to engage the parking brake.

## Releasing the Parking Brake

Depress the brake pedal/clutch-brake pedal and move the Park Brake or Park Brake/CVT Drive Control Lever out of the ENGAGED position and into the DISENGAGED position for Hydrostatic and Foot Control CVT models. For CVT models, depress the brake pedal/clutch-brake pedal and move the parking brake lever out of the ENGAGED position and into the desired speed setting.

## Reverse Caution Mode (If equipped)

The REVERSE CAUTION MODE position of the ignition switch allows the tractor to be operated in reverse with the PTO (Blade Engage) Lever in the engaged (ON) position.

**NOTE:** Mowing in reverse is not recommended.

### ⚠ WARNING

Use extreme caution while operating the tractor in the REVERSE CAUTION MODE. Always look down and behind before and while backing. Do NOT operate the tractor with children or others around. Stop the tractor immediately if someone enters the area.

To use the REVERSE CAUTION MODE:

**NOTE:** The operator MUST be seated in the tractor seat.

1. Start the engine as previously instructed.
2. Turn the ignition key from the NORMAL MOWING (a) position to the REVERSE CAUTION MODE (b) position of the ignition switch. See Figure 16.

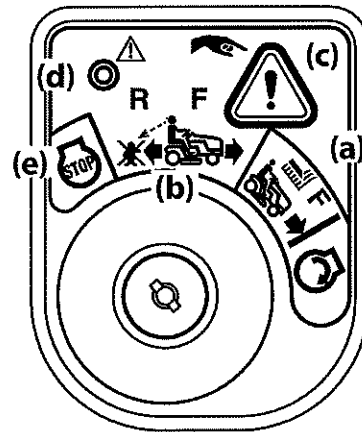

Figure 16

3. Press and hold the REVERSE CAUTION MODE BUTTON (c) at the top, right corner of the ignition module for 3 seconds. The red indicator light (d) at the top, left corner of the ignition module will be ON while activated. See Figure 16.
4. Once activated (Indicator light ON), the tractor can be driven in reverse with the PTO (Blade Engage) in the engaged (ON) position.

# OPERATION

5. Always look down and behind before and while backing up slowly to make sure no children are around. After resuming forward motion, return key to the NORMAL MOWING (a) position to return to normal mowing operation.

The REVERSE CAUTION MODE (b) will remain activated until (see Figure 16 on page 18):

- a. The key is placed in either the NORMAL MOWING (a) position or STOP (e) position.
- b. The operator leaves the seat/the parking brake is set (manual PTO).

## Engaging the PTO (Blade Engage)

Engaging the PTO (Blade Engage) transfers power to the cutting deck. To engage the PTO:

1. Move the throttle to the FAST position.
2. Push the PTO (Blade Engage) Lever forward into the engaged (ON) position. See Figure 17.

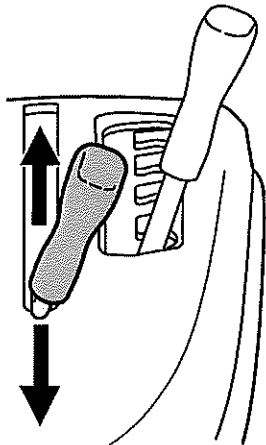

Figure 17

3. To disengage the PTO (Blade Engage), pull the lever backward, into the disengaged PTO (Blade Engage) OFF position.

## Mowing

### ⚠ WARNING

To help avoid blade contact or a thrown object injury, keep bystanders, helpers, children, and pets at least 75 feet (23 meters) from the machine while it is in operation. Stop machine if anyone enters the area.

### ⚠ WARNING

Make certain the area to be mowed is free of debris, sticks, stones, wire, or other objects that can be thrown by the rotating blades.

**NOTE:** Do not engage the mower deck when lowered in grass. Premature wear and possible failure of the "V" belt and PTO clutch will result. Fully raise the deck or move to a non-grassy area before engaging the mower deck.

- Mow up and down slopes, not across. If mowing a slope, start at bottom and work upward to ensure turns are made uphill.
- Do not mow at high ground speed, especially if a mulch kit or grass collector is installed.
- Do not cut the grass too short. Short grass is prone to weed growth and yellows quickly in dry weather.
- Always operate the tractor with the throttle in the FAST position while mowing.
- On the first pass, pick a point on the opposite side of the area to be mowed. Follow the point to maintain a straight line.
- Engage the PTO and move the throttle control or throttle/choke control to the FAST position.
- Lower the mower deck to the desired height setting.
- For best results it is recommended that the first two laps be cut with the discharge thrown towards the center. After the first two laps, reverse the direction to throw the discharge to the outside for the balance of cutting. This will give a better appearance to the lawn.

**NOTE:** The speed of the tractor will affect the quality of the mower cut. Mowing at full speed will adversely affect the cut quality.

- Your tractor is designed to cut normal residential grass of a height no more than 10" (25 cm). Do not attempt to mow through unusually tall, dry grass (e.g., pasture) or piles of dry leaves. Dry grass or leaves may contact the engine exhaust and/or build up on the tractor.
- Do not attempt to mow heavy brush and weeds or extremely tall grass. Your tractor is designed to mow lawns, not clear brush.
- Keep the blades sharp and replace the blades when worn.
- When approaching the other end of the strip, slow down or stop before turning. A three point turn is recommended.
- Align the tractor with an edge of the mowed strip and overlap approximately 3" (7.6 cm).
- Direct the tractor on each subsequent strip to align with a previously cut strip.
- To prevent rutting or grooving of the turf, if possible, change the direction that the strips are mowed by approximately 45° for the next and each subsequent mowing.

When stopping the tractor for any reason while on a grass surface, always:

- Engage the parking brake.
- Shut engine off and remove the ignition key.
- Doing so will minimize the possibility of having your lawn "browned" by hot exhaust from your tractor's running engine.

# SERVICE AND MAINTENANCE

## WARNING

Before performing any type of maintenance/service, disengage all controls and stop the engine. Wait until all moving parts have come to a complete stop. Allow the engine to cool. Disconnect spark plug wire and ground it against the engine to prevent unintended starting.

Follow the Maintenance Schedule given below. This chart describes service guidelines only. Refer to the Engine Operator's Manual for engine maintenance items listed in the table below.

	Before Each Use	After First 5 Hours	Every 10 Hours	Every 25 Hours	Every 50 Hours	Every 100 Hours	Every 200 Hours	Prior to Storing	See Engine Manual
Check/Clean Engine Intake Screens & Cooling Fans #	✓							✓	
Check/Clean Exhaust Manifold, Muffler Pipe & Muffler Shields #	✓							✓	
Check/Clean Top & Underside of Deck, Under & Around Spindle Covers & Belt Area #	✓							✓	
Check/Clean Around Fuses, Wiring & Wiring Harnesses #	✓							✓	
Check/Clean Around Transmission, Axle & Fans #	✓							✓	
Check Air Filter for Dirty, Loose or Damaged Parts	✓								
Check Engine Oil Level	✓								
Clean Battery Terminals			✓					✓	
Grease All Lubrication Points			✓					✓	
Check Engine Intake Screen/Clean as Needed			✓					✓	
Check Blades/Sharpen or Replace as Needed			✓					✓	
Check Tire Pressure			✓					✓	
Check/Clean Underside of Deck			✓						
Check Safety Interlock System			✓					✓	
Check Mower Blade Stop Time			✓					✓	
Inspect & Lube Deck Wheels				✓				✓	
Check Deck Level/Pitch				✓				✓	
Check Belts & Pulleys for Damage/Wear					✓				
Check that All Hardware is in Place & Secure						✓			
Check Engine Mounting Bolt Torque (Tighten to 325-450 in-lbs (37-50 N-m))		✓			✓			✓	✓
Check Blade Mount Nut Torque (Tighten to 70-90 ft-lbs (95-122 N-m))		✓			✓			✓	
Check Spark Plug Condition & Gap						✓		✓	✓
Engine Break-In Oil Change		✓							✓
Change Engine Oil					✓			✓	✓

# SERVICE AND MAINTENANCE

	Before Each Use	After First 5 Hours	Every 10 Hours	Every 25 Hours	Every 50 Hours	Every 100 Hours	Every 200 Hours	Prior to Storing	See Engine Manual
Check Fuel System (Lines, Tank, Cap, Fittings)		✓			✓			✓	✓
Check Spark Arrestor		✓			✓			✓	✓
Replace Oil Filter					✓			✓	✓
Clean or Change Air Filter					✓				✓
Replace Fuel Filter					✓				✓
Have Valve Lash Checked & Adjusted*									✓

\* -- Have this item performed by an authorized service dealer

# -- Perform more often in dry conditions and/or when mulching

**NOTE:** This Operator's Manual covers several models. Tractor features may vary by model. Not all features in this manual are applicable to all tractor models and the tractor depicted may differ from yours.

## Post-Operation Tractor Care

After each operation of the tractor, the following procedures should be implemented to extend the life of your tractor and ensure safe operating conditions.

### ⚠ WARNING

Failure to follow these recommendations may result in serious injury to yourself or others and may cause damage to the tractor.

## Cleaning the Underside of the Deck

### DECK WASH SYSTEM (IF EQUIPPED)

Your tractor's deck may be equipped with a water port on its surface as part of its deck wash system.

Use the deck wash system to rinse grass clippings from the deck's underside and prevent the buildup of corrosive chemicals. Complete the following steps AFTER EACH MOWING:

1. Attach the nozzle adapter to a standard garden hose connected to a water supply.
2. Move the tractor to an area within reach of the hose where the dispersal of wet grass clippings is acceptable. Disengage the PTO, engage the parking brake and stop the engine.
3. Pull back the lock collar (a) of the nozzle adapter (b) and push the nozzle adapter onto the deck wash nozzle (c). Release the lock collar to lock the nozzle adapter on the deck wash nozzle. See Figure 18.

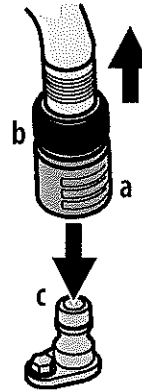

Figure 18

4. Turn on the water supply.
5. From the tractor operator's seat, start the engine and engage the PTO. Allow to run as needed. Disengage the PTO and stop the engine.
6. Turn off the water supply.
7. Pull back the lock collar of the nozzle adapter to disconnect the nozzle adapter from the deck wash nozzle.

## Cleaning the Tractor

### ⚠ WARNING

If the tractor has been recently run, the engine, muffler, and surrounding metal surfaces will be hot and can cause burns to the skin. Let the engine cool for at least five minutes. Exercise caution to avoid burns.

Your tractor should be cleaned after each use and under certain conditions, i.e. dry conditions and/or mulching situations, additional cleaning may be necessary.

One of the best ways to keep your tractor running efficiently and to reduce fire risk is to regularly remove debris buildup from the tractor. Follow the recommendations below and contact your authorized dealer with any questions.

- Allow the tractor to cool at least five minutes in an open area before cleaning.



# SERVICE AND MAINTENANCE

**NOTE:** Using a pressure washer or garden hose is not recommended for cleaning your tractor other than to clean the underside of the deck. It may cause damage to electrical components, spindles, pulleys, bearings or the engine. The use of water will result in shortened life and reduce serviceability.

- Clean under the hood, including exhaust manifold, around fuses, all wiring and harnesses, muffler pipe, muffler shield, engine intake screens and cooling fins, etc. See Figure 19.

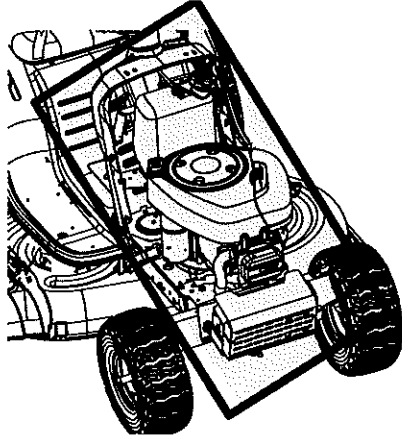

Figure 19

- Clean the top of the tractor deck, under the spindle covers, and belt area. See Figure 20.

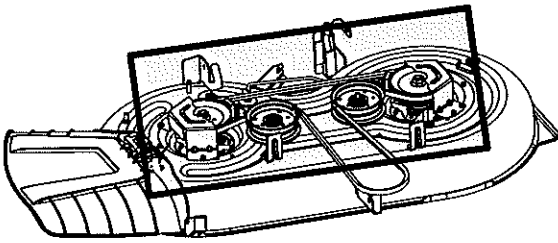

Figure 20

- Clean around and near the transmission, axle and the fan area. See Figure 21.

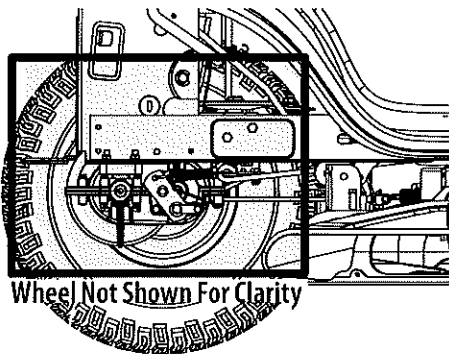

Figure 21

- Debris can accumulate anywhere on the tractor, especially on horizontal surfaces. Additional cleaning may be necessary when mowing in dry conditions or when mulching.

- Fuel leaks/spills, oil leaks/spills and excess lubrication can also become collection sites for debris. Immediate repair and cleaning up of oil or fuel spills can help reduce fire hazards.
- In addition to cleaning the tractor before operating and storing, do not attempt to mow unusually tall grass, 10" (25 cm) or higher, dry grass (e.g., pasture) or piles of dry leaves. Dry grass or leaves may contact the engine exhaust and/or build up on the tractor deck presenting a potential fire hazard.

## Storing the Tractor

- Allow the tractor to cool at least five minutes in an open area before storing.
- Do not park the tractor near any flammable materials (wood, cloth, or chemicals) or any open flames or other potential source of ignition (furnace, water heater or any other type of heater).
- Remove all combustible materials from the tractor before storing. Empty cargo boxes, grass catchers or containers.
- Always shut off fuel flow when storing or transporting if tractor is equipped with a fuel shutoff.
- Check the fuel system (lines, tank, cap and fittings) frequently for cracks or leaks. Repair and clean as necessary.

## Maintenance

### ENGINE

#### ⚠ WARNING

Allow machine to cool in an open area for at least five minutes before storing or refuelling.

Refer to the Engine Operator's Manual for all engine issues and questions.

**NOTE:** Maintenance, repair or replacement of the emission control devices and systems which are being done at owner's expense may be performed by any engine repair establishment or individual. Warranty repairs must be performed by an authorized dealer.

### CHANGING ENGINE OIL

#### ⚠ WARNING

If the engine has been recently run, the engine, muffler, and surrounding metal surfaces will be hot and can cause burns to the skin. Let the engine cool for at least five minutes. Exercise caution to avoid burns.

### OIL DRAIN TUBE MODELS

**NOTE:** The oil filter should be changed at every oil change interval.

To complete the oil change, proceed as follows:

1. Run the engine for a short time to warm the engine oil. The oil will flow more freely and carry away more impurities. Use care to avoid burns from hot oil.
2. Open the tractor's hood and locate the oil drain port on the side of the engine.

# SERVICE AND MAINTENANCE

3. Place an appropriate oil collection container with at least a 2.5 quart (2.36 L) capacity below the opening of the oil drain tube, to collect the used oil. Remove the oil fill cap/dipstick from the oil fill tube.
4. Open the protective cap on the end of the oil drain valve to expose the drain port. See Figure 22.

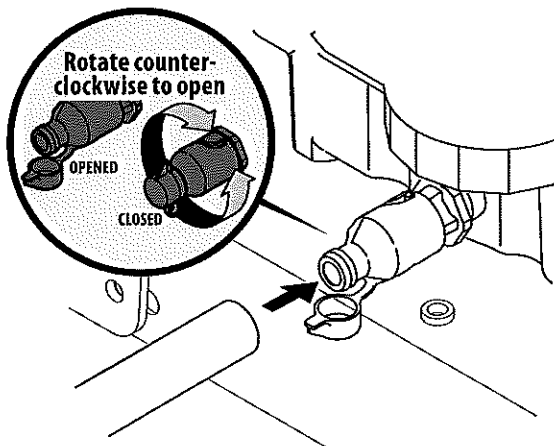

Figure 22

5. Push the oil drain tube (packed with this manual) onto the oil drain port. Route the opposite end of the tube into an appropriate oil collection container with at least a 2.5 quart (2.36 L) capacity to collect the used oil.
6. The engine is equipped with a twist-and-pull drain port. Turn the oil drain valve 1/4-turn counter-clockwise, then pull outward to begin draining oil. After the oil has finished draining, push the end of the oil drain valve back in and turn 1/4-turn clockwise to close the oil drain. Re-cap the end of the oil drain valve to keep debris from entering the drain port.
7. Replace the oil filter, and refill the engine with new oil as instructed in the Engine Operator's Manual.
8. Reinstall the oil fill cap/dipstick.

**NOTE:** Place an absorbent towel beneath the oil filter to keep oil off the engine pulley.

**NOTE:** Observe proper disposal laws and regulations for gas, oil, etc. to protect the environment.

**NOTE:** Maintenance, repair or replacement of the emission control devices and systems which are being done at the owner's expense may be performed by any engine repair establishment or individual. Warranty repairs must be performed by an authorized dealer.

## OIL DRAIN SLEEVE MODELS

To complete the oil change, proceed as follows:

1. Run the engine for a short time to warm the engine oil. The oil will flow more freely and carry away more impurities. Use care to avoid burns from hot oil.
2. Open the tractor's hood and locate the oil drain port on the side of the engine.

3. Place an appropriate oil collection container with at least a 2.5 quart (2.36 L) capacity below the opening of the oil drain tube, to collect the used oil. Remove the oil fill cap/dipstick from the oil fill tube.
4. Snap the small end of the oil drain sleeve onto the oil sump. See Figure 23.

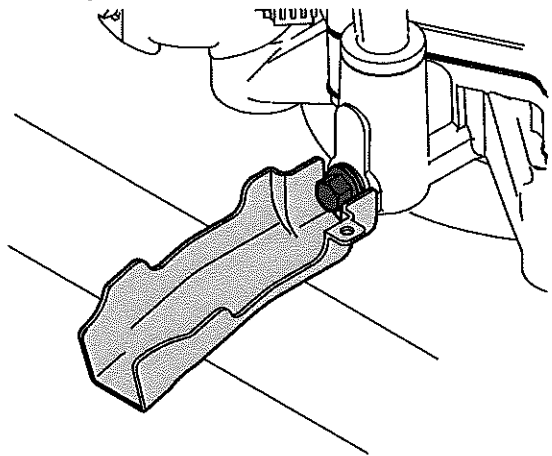

Figure 23

5. Remove drain plug and drain oil into collection container.
6. Replace the oil filter as instructed in the separate Engine Operator's Manual.
7. Reinstall oil drain plug and refill the engine with new oil as instructed in the Engine Operator's Manual.
8. Reinstall the oil fill cap/dipstick.

## Lubrication

### ⚠ WARNING

Before lubricating, repairing, or inspecting, always disengage PTO, set parking brake, stop engine, and remove key to prevent unintended starting.

Using a quality lubricating oil, lubricate all lubrication points. Refer to Maintenance Schedule chart located in this manual for proper service intervals.

### LUBRICATING PIVOT POINTS & LINKAGE

Lubricate all the pivot points on the drive system, parking brake and lift linkage per the Maintenance Chart.

**NOTE:** It is not necessary to grease the steering pinion/sector gear interface. Doing so will allow dirt to accumulate and can affect steering performance.

### REAR WHEELS

The rear wheels should be removed from the axles once a season. Lubricate the axles and the rims with an all-purpose grease before re-installing them.

# SERVICE AND MAINTENANCE

## FRONT AXLES (IF EQUIPPED)

Each end of the tractor's front pivot bar may be equipped with a grease fitting. Lubricate with a No. 2 multi-purpose grease applied with a grease gun per the Maintenance Schedule. See Figure 24.

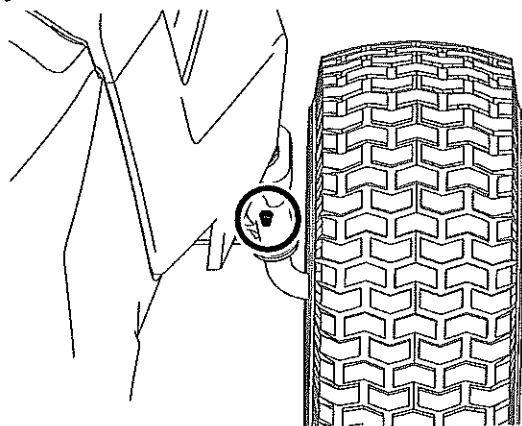

Figure 24

## Spark Arrestor Maintenance (If equipped)

Spark arrestor assemblies must be inspected and cleaned periodically (see the Maintenance Schedule chart in this manual). Visually inspect the screen for tears, broken wires or loose welds. Replace the spark arrestor assembly if any of these conditions exist. If the screen is in good condition, clean the screen by brushing away loose dirt or carbon particles.

## Tires

Keep the tires inflated to the recommended pressures. Improper inflation will shorten the tire service life. See the tire side wall for proper inflation pressures. Refer to Maintenance Schedule chart located in this manual for proper service intervals.

Observe the following guidelines:

- Do not inflate a tire above the maximum pressure shown on the sidewall of the tire.
- Do not reinflate a tire that has been run flat or seriously under-inflated. Have it inspected and serviced by a qualified tire mechanic.

## Off-Season Storage

If your tractor is not going to be operated for an extended period of time (30 days to approximately six months), the tractor should be prepared for storage. Store the tractor in a dry and protected location. If stored outside, cover the tractor (including the tires) to protect it from the elements. The procedures outlined below should be performed whenever the tractor is placed in storage.

1. Change the engine oil and filter following the instructions provided in this manual as well as the Engine Operator's Manual provided with this tractor.

## ⚠ WARNING

Never store the tractor with fuel in the tank indoors or in poorly ventilated enclosures, where fuel fumes may reach an open flame, spark, or pilot light as on a furnace, water heater, clothes dryer, etc.

2. If storing the tractor for 30 days or more:
  - a. To prevent gum deposits from forming inside the engine's carburetor and causing possible malfunction of the engine, the fuel system must be either completely emptied, or the gasoline must be treated with a stabilizer to prevent deterioration.
  - b. Using a fuel stabilizer for storage between 30 and 90 days:
    - Read the product manufacturer's instructions and recommendations.
    - Add to clean, fresh gasoline the correct amount of stabilizer for the capacity of the fuel system.
    - Fill the fuel tank with treated fuel and run the engine for 2-3 minutes to get stabilized fuel into the carburetor.
    - Fuel left in the fuel tank deteriorates and will cause serious starting problems.
  - c. Emptying the fuel system for storage of more than 90 days:
    - Prior to putting the tractor in storage, monitor fuel consumption with the goal of running the fuel tank empty.
    - Run the engine until it begins to stall. Use the choke to keep the engine running until all fuel in the carburetor has been exhausted.
    - Referring to the Engine Operator's Manual, drain the fuel from the carburetor bowl.
3. Clean the engine and the entire tractor thoroughly.

**NOTE:** Using a pressure washer or garden hose is not recommended for cleaning your tractor other than to clean the underside of the deck. It may cause damage to electrical components, spindles, pulleys, bearings or the engine. The use of water will result in shortened life and reduce serviceability.

4. Fully charge the battery, then disconnect the negative cable at the battery to prevent possible discharge. Recharge the battery periodically when in storage.

**NOTE:** Remove the battery if exposed to prolonged periods of sub-freezing temperatures. Store in a cool, dry location where temperatures are above freezing.

5. Lubricate all lubrication points.

## Removing the Tractor from Storage

1. Check the engine oil.
2. Fully charge the battery and inflate the tires to the recommended pressure. See tire side wall for proper tire inflation pressure.

# SERVICE AND MAINTENANCE

3. Fill the fuel tank with clean, fresh gasoline.
4. Start the engine and allow to idle for a few minutes to ensure engine is operating properly.
5. Drive the tractor without a load to make certain all the tractor systems are functioning properly.

## Leveling the Deck (Side-to-Side)

### ⚠ WARNING

Tractor blades are sharp. Wrap the blade or wear gloves, and use extra caution when servicing them.

1. With the tractor parked on a firm, level surface, place the deck lift lever in the second notch from the top (second highest position) and rotate both blades so that they are perpendicular with the tractor.
2. Measure the distance from the outside of the left blade tip to the ground and the distance from the outside of the right blade tip to the ground. Both measurements taken should be equal. If they are not, proceed to the next step.
3. Under the rear fenders inside the wheels there is a lift adjustment hex cap screw and gear for each side of the deck. See Figure 25.

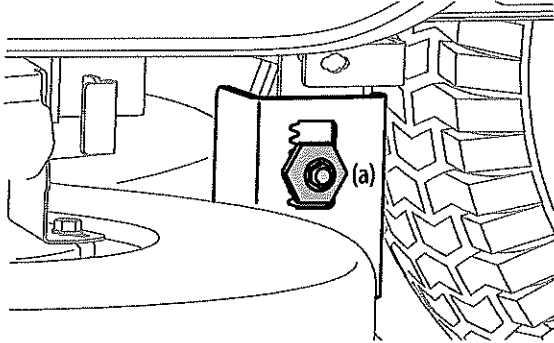

Figure 25

4. Loosen, but do NOT remove, the hex cap screw (a) on the left deck hanger bracket. See Figure 25.
5. Minor adjustments should be made to the adjustment gear immediately behind the hex cap screw loosened in the previous step (clockwise/up or counter-clockwise/down).
6. When the proper adjustment is achieved, tighten the hex cap screw (a) on the left deck hanger bracket. See Figure 25.
7. The deck is properly balanced when both blade tip measurements taken earlier are equal.

## Leveling the Deck (Pitch/Front-to-Rear)

### ⚠ WARNING

Tractor blades are sharp. Wrap the blade or wear gloves, and use extra caution when servicing them.

The front of the deck is supported by a stabilizer bar that can be adjusted to level the deck from front to rear. The front of the deck should be 1/4"-3/8" (6.35 mm-9.5 mm) lower than the rear of the deck. Adjust if necessary as follows:

1. Park the tractor on a firm, level surface, place the lever for lifting the platform on the second to the top notch (second highest position) and rotate the end of the blade nearest the discharge chute so that it is parallel with the tractor.
2. Measure the distance from the front of the blade tip to the ground and the rear of the blade tip to the ground. The front of the deck should be between 1/4"-3/8" (6.35 mm-9.5 mm) less than the rear of the deck.
3. Determine the approximate distance necessary for proper adjustment and proceed, if necessary.
4. To **raise** the front of the deck, loosen the outer nut then tighten (thread inward) the inner nut against the front hanger bracket. See Figure 26. When proper adjustment is achieved, re-tighten the outer nut to 25-30 ft-lbs (34-41 N-m).
5. To **lower** the front of the deck, loosen the outer nut then loosen (thread outward) the inner nut, away from the front hanger bracket. See Figure 26. When proper adjustment is achieved, re-tighten the outer nut.

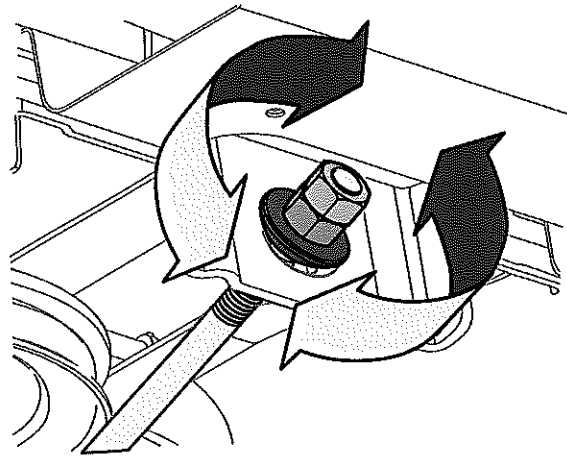

Figure 26

## Adjusting the Deck Wheels

### ⚠ WARNING

Keep hands and feet away from the discharge opening of the cutting deck.

**NOTE:** The deck wheels are an anti-scalp feature of the deck and are not designed to support the weight of the deck.

The deck wheels should be approximately 1/4"-1/2" (6.35 mm-12.7 mm) above the ground when the deck is set in the desired height setting. To adjust the deck wheels see the Assembly section for instructions.

## Service

### ELECTRICAL SYSTEM

A fuse is installed to protect the tractor's electrical system from damage caused by excessive amperage. Always use the same capacity fuse for replacement. If the electrical system does not function, check for a blown fuse.

# SERVICE AND MAINTENANCE

If you have a recurring problem with blown fuses, have the tractor's electrical system checked by your authorized service dealer.

## RELAYS AND SWITCHES

There are several safety switches in the electrical system. If a function of the safety interlock system described earlier is not functioning properly, have the electrical system checked by your authorized service dealer.

## PARKING BRAKE ADJUSTMENT

If the tractor does not come to a complete stop when the brake pedal is completely depressed, or if the tractor's rear wheels can roll with the parking brake applied (and the hydrostatic relief valve open, if equipped), the brake is in need of adjustment. See your authorized service dealer to have the brake adjusted.

## HYDROSTATIC NEUTRAL ADJUSTMENT

If the tractor creeps forward or rearward when neither the forward nor reverse pedal is depressed, contact your local authorized dealer to have the neutral setting properly adjusted.

## Wheel Alignment

If your tractor pulls to one side or is out of alignment, a wheel alignment might be necessary. Contact an authorized service dealer to have the wheels properly aligned.

## Deck Removal

### ⚠ WARNING

Use caution to avoid pinching your fingers when rolling the belt off the PTO pulley.

To remove the cutting deck, proceed as follows:

1. Move the tractor to a level surface, disengage the PTO, stop the engine and ENGAGE the parking brake.
2. Lower the deck by moving the deck lift lever into the bottom notch on the right fender.
3. Remove the belt-keeper rod (a), from around the tractor's engine pulley, by removing the self-tapping screw (b) that secures it. See Figure 27.

**NOTE:** Make a note what hole the other end of the belt-keeper rod is inserted in for reinstallation purposes.

4. Remove the belt (c) from around the tractor's engine pulley and idler pulley(s). See Figure 27.

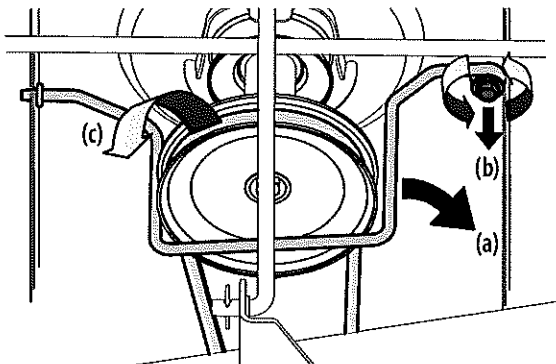

Figure 27

5. Looking at the cutting deck from the left side of the tractor, locate the bow-tie pin (a) that secures the deck support rod (b) on the rear left side of the deck. See Figure 28. Remove the bow-tie pin (a) that secures the deck support rod (b), and carefully remove the deck support from the deck lift arm.

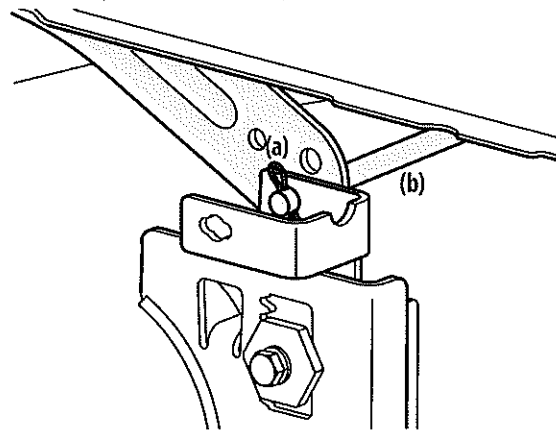

Figure 28

6. Repeat Step 5 on the tractor's right side.
7. Move the deck lift lever into the top notch on the right fender to raise the deck lift arms up and out of the way.
8. On 38" decks, gently slide the cutting deck toward the front of the tractor carefully guiding the hooks on the deck off of the deck stabilizer rod. See Figure 29.

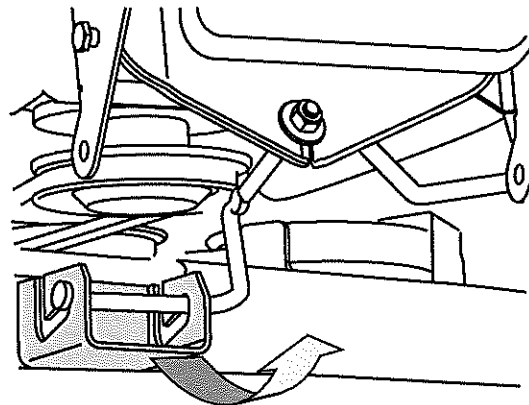

Figure 29

9. On 36", 42" and 46" decks, remove the bow-tie pin (a) securing the deck stabilizer rod (b) to the deck. Slide the deck lift rod from the mounting weldment on the deck as seen in Figure 30.

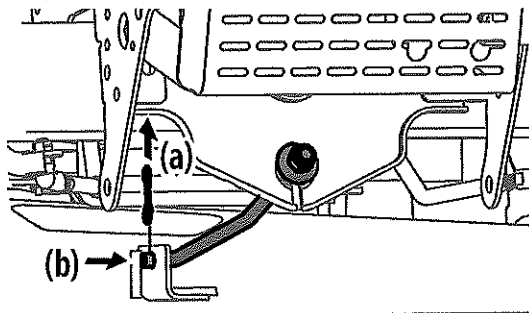

Figure 30

# SERVICE AND MAINTENANCE

10. Carefully remove the PTO cable (a) from the rear of the cutting deck by removing the bow-tie clip (b) which secures it. Remove the spring (c) from the deck idler bracket. See Figure 31.

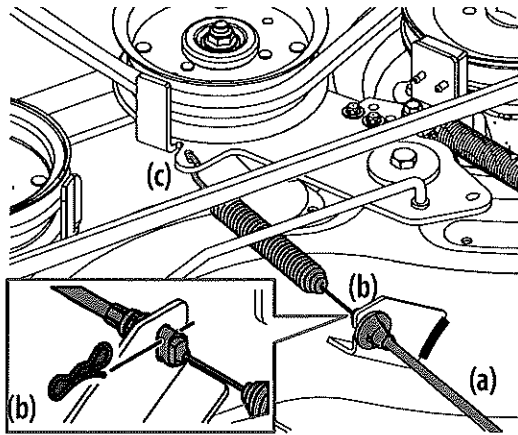

Figure 31

11. Gently slide the cutting deck (from the left side) out from underneath the tractor.

**NOTE:** To reinstall the deck after service, reverse the order of deck removal Steps 1-11 in this section.

## Removing the Blade

### ⚠ WARNING

Shut the engine off and remove ignition key before removing the cutting blade(s) for sharpening or replacement. Protect your hands by using heavy gloves when grasping the blade.

Periodically inspect the blade and/or spindle for cracks or damage, especially after you've struck a foreign object. Do not operate the tractor until damaged components are replaced.

If the cutting edge of the blade has previously been sharpened, or if any metal separation is present, replace the blades with new ones.

1. Remove the deck from beneath the tractor, (refer to Deck Removal) then gently flip the deck over to expose its underside.
2. Place a block of wood between the center deck housing baffle and the cutting blade to act as a stabilizer. See Figure 32.

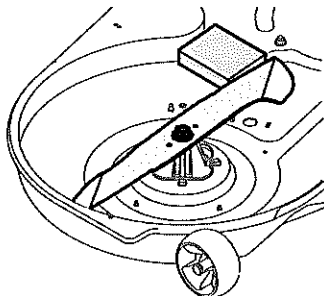

Figure 32

3. Remove the hex flange nut that secures the blade to the spindle assembly. See Figure 32.

## Installing the Blade

1. With the deck removed gently flip the deck over to expose its underside.
2. Line up the hole in the center of the blade with the retainer at the bottom of the spindle assembly, and the side stamped with "grass-side", "Bottom" or with a part number, so that it will be facing the ground with the deck reinstalled and in the proper operating position.
3. Place a block of wood between the deck housing baffle and the cutting blade to act as a stabilizer. See Figure 32.
4. Thread on the hex flange nut to secure the blade to the spindle assembly. Use a torque wrench to tighten the blade spindle hex flange nut to 80-90 ft-lbs (95-122 N-m).

**NOTE:** When replacing or reinstalling the blade, be sure to install the blade with the side of the blade marked "grass-side", "Bottom" or with a part number stamped in it facing the ground.

## Sharpening the Blade

1. To properly sharpen the cutting blades, remove equal amounts of metal from both ends of the blades along the cutting edges, parallel to the trailing edge, at a 25° to 30° angle. Always grind each cutting blade edge equally to maintain proper blade balance. See Figure 33.

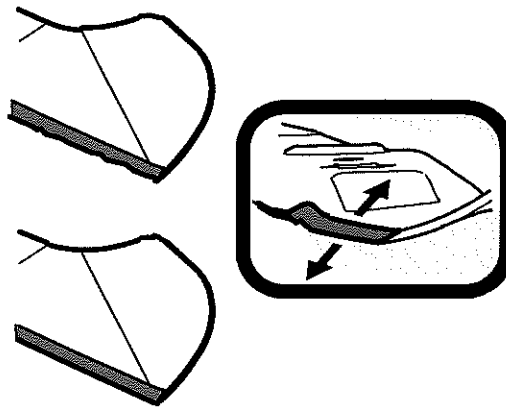

Figure 33

2. Test the blade's balance using a blade balancer. Grind metal from the heavy side until it balances evenly.

### ⚠ WARNING

A poorly balanced blade will cause excessive vibration, may damage the tractor, and/or result in personal injury.