

HILTI

SD 4500 / SD 2500

Operating instructions

en

Mode d'emploi

fr

Manual de instrucciones

es

Manual de instruções

pt



285702



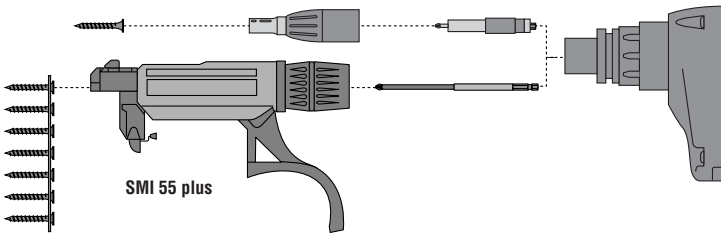
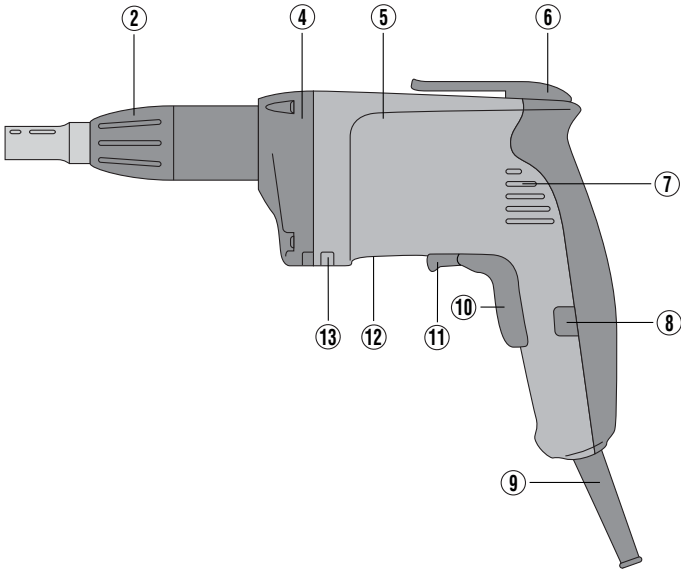
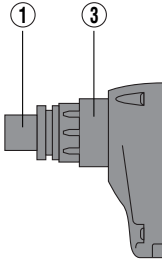

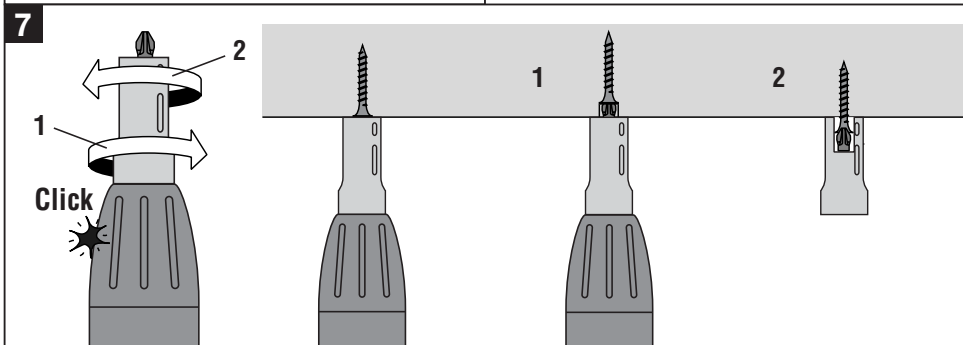
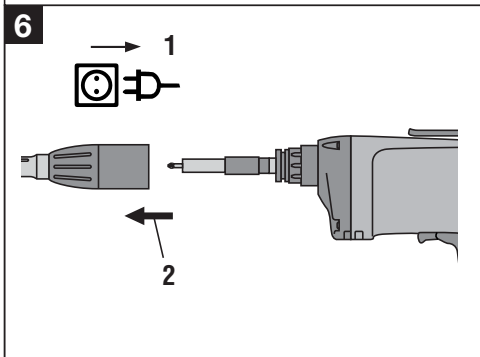
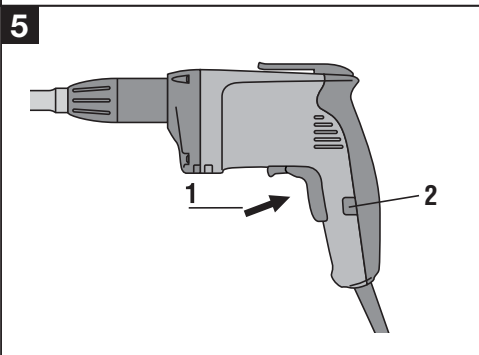
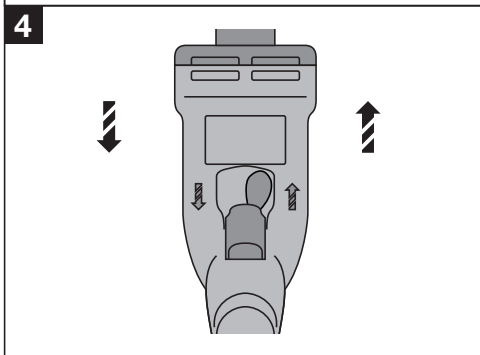
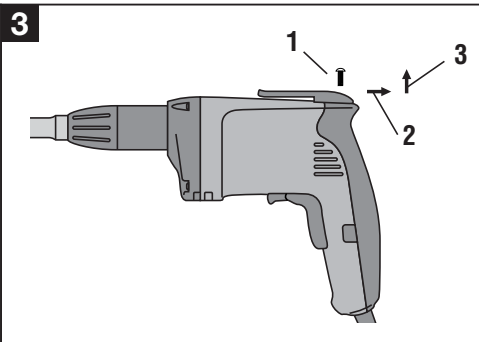
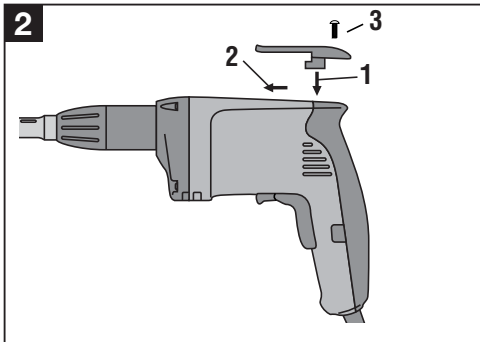

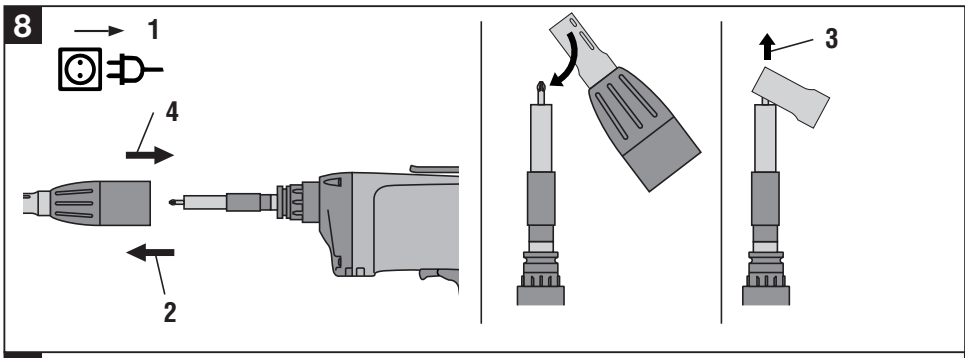
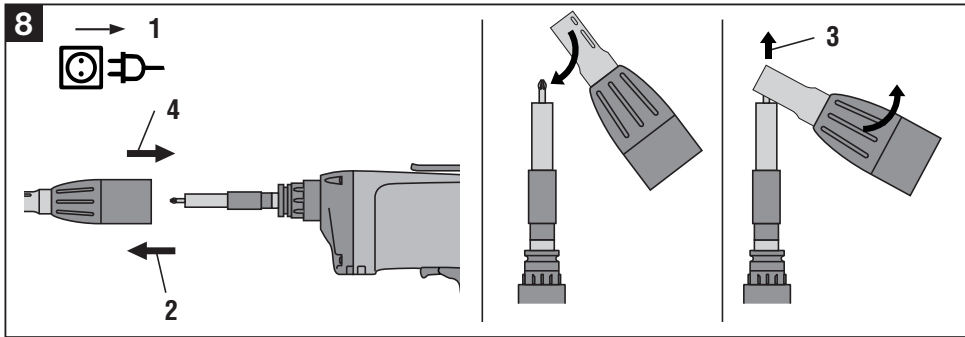

SD 4500 / SD 2500 drywall screwdrivers

It is essential that the operating instructions are read before the tool is operated for the first time.

Always keep these operating instructions with the tool.

Ensure that the operating instructions are with the tool when it is given to other persons.

Operating controls and parts **1**

- ① 1/4" chuck (for bit holder, magazine bit)
- ② Adjustable depth gauge (with bit change function)
- ③ Tool / accessory interface (click connection)
- ④ Coupling system / gearing
- ⑤ Motor
- ⑥ Belt hook
- ⑦ Motor cooling air intake
- ⑧ Lockbutton for sustained operation
- ⑨ Supply cord
- ⑩ On / off switch (with electronic speed control)
- ⑪ Forward / reverse switch
- ⑫ Type plate
- ⑬ Cooling air exit with controlled air flow

Contents	Page
1. General information	1
2. Description	2
3. Tools and accessories	3
4. Technical data	3
5. Safety rules	4
6. Before use	5
7. Operation	6
8. Care and maintenance	7
9. Disposal	7
10. Manufacturer's warranty – tools	7

1. General information

1.1 Safety notices and their meaning

-CAUTION-

Draws attention to a potentially dangerous situation that could lead to minor personal injury or damage to the equipment or other property.

-NOTE-

Draws attention to instructions and other useful information.

1.2 Pictograms

Warning signs



General warning



Warning: electricity

Obligation signs



Wear eye protection

Symbols



Read the operating instructions before use.



Return waste material for recycling

1 These numbers refer to the corresponding illustrations. The illustrations can be found on the fold-out cover pages. Keep these pages open while studying the operating instructions.

In these operating instructions, the SD 4500 and / or SD 2500 screwdriver is referred to as « the power tool ».

Location of identification data on the power tool

The type designation can be found on the rating plate and the serial number on the side of the motor housing. Make a note of this data in your operating instructions and always refer to it when making an enquiry to your Hilti representative or service department.

Type: _____

Serial No.: _____

2. Description

2.1 Use of the power tool as intended

The **SD 4500** is a hand-held, corded power tool for professional use in the drywall installation trade.

The **SD 2500** is a hand-held, corded power tool for professional use in the woodworking and drywall installation trades.

These power tools are used for driving and removing the recommended types of screws in the corresponding materials of the specified thickness.

The SD 4500 and SD 2500 are designed to be used in conjunction with a screw magazine (SMI 55 plus) and tool extension (SME) if desired.

The power tools are intended for use on construction sites of all kinds for applications in the drywall installation and woodworking trades.

Only the specified screwdriving bits, magazine and accessories should be used with the power tools.

The general safety precautions listed in the operating instructions must be observed.

2.2 Main applications

Application	Screw type / diameter in mm	SD 4500	SD 2500
Fastening drywall panels to metal profiles (track) ≤ 0.88 mm / 20 ga	Needle-point drywall screws, type S-DS 01	X	
Fastening drywall panels to metal profiles (track) ≤ 2.25 mm / 25–16 ga	Drill-point drywall screws, type S-DD 01	X	
Fastening metal profiles to metal profiles (max. total thickness 2.5 mm / 13–12 ga)	Special drywall screws with drill point, type S-DD 02 und S-DD 03	X	
Fastening drywall panels to wood	Needle-point drywall screws, type S-DS 03	X	
Fastening drywall panels to metal profiles (≤ 0.88 mm / 20 ga) and wood frames	Needle-point drywall screws, type S-DS 14	X	
Fastening chipboard (particle board) to wood frames	Needle-point drywall screws, Type S-DS 03	X	X
Fastening: Wood to wood Wood to chipboard Chipboard to wood Screws up to 140 mm (5½ in) in length	Wood screws	X	X
Fastening wood to metal Steel grade: ST 37 up to 12 mm (½ in) Steel grade: ST 52 up to 8 mm (⅜ in)	Self-drilling wing screws with drill point, type S-WW		X

Items supplied as standard with the SD 4500

- Power tool
- Depth gauge
- Belt hook
- S-BH 75 M bit holder, S-B PH2 DRY bit
- Operating instructions
- Cardboard box

Items supplied as standard with the SD 2500

- Power tool
- Depth gauge
- Belt hook
- S-BH 75 M bit holder, S-B PH2 DRY bit
- Operating instructions
- Cardboard box

3. Insert tools and accessories

		SD 4500	SD 2500
Belt hook		X	X
Depth gauge	S-DG-D 11 x 50 for 50 mm (2") bit holder	X	X
Depth gauge	S-DG-D 11 x 75 for 75 mm (3") bit holder	X	X
Bit and bit holder	S-BH 75 M and S-BH 50 M bit holders, PH2, SQ and TX bits	X	X
Magazine	SMI 55 plus	X	X
Extension	SME extension for working on floors and ceilings	X	X

4. Technical data

Tool	SD 4500	SD 2500
Rated power	740 W	740 W
Rated voltage	120 V	120 V
Rated current	6.5 A	6.5 A
Rated frequency	60 Hz	60 Hz
Rated no-load running speed	0–4500 r.p.m.	0–2500 r.p.m.
Chuck	1/4" DIN 3126 / ISO 1173	1/4" DIN 3126 / ISO 1173
Weight of tool	1.4 kg (3.1 lbs)	1.5 kg (3.3 lbs)
Dimensions (L×W×H)	290 × 75 × 160 / 168 mm (11.4 × 2.9 × 6.3 / 6.6 in)	303 × 75 × 160 / 168 mm (11.9 × 2.9 × 6.3 / 6.6 in)
Max. torque	9.5 Nm (84 in-lbs)	19 Nm (168 in-lbs)
Speed control	Electronic, by control switch	
Forward / reverse	Switch with interlock to prevent changing direction while the motor is running	
Protection class	Electrical protection class II  (double insulated) in accordance with UL/CSA60745 Electrical protection class I, grounded (50 ft cord with Twist Lock Plug)	
Mechanical notch-type clutch		
Vibration-absorbing grip		

5. Safety rules

5.1 General safety rules

-WARNING-! Read all instructions! *Failure to follow all instructions listed below may result in electric shock, fire and / or serious injury. The term "power tool" in all of the warnings listed below refers to your mains operated (corded) power tool or battery operated (cordless) power tool.*

SAVE THESE INSTRUCTIONS.

5.1.1 Work area safety

- Keep the work area clean and well lit.** *Cluttered and dark areas invite accidents.*
- Do not operate power tools in explosive atmospheres, such as in the presence of flammable liquids, gases or dust.** *Power tools create sparks which may ignite the dust or fumes.*
- Keep children and bystanders away while operating a power tool.** *Distractions can cause you to lose control.*

5.1.2 Electrical safety

- Power tool plugs must match the outlet. Never modify the plug in any way. Do not use any adapter plugs with earthed (grounded) power tools.** *Unmodified plugs and matching outlets will reduce risk of electric shock.*
- Avoid body contact with earthed or grounded surfaces such as pipes, radiators, ranges and refrigerators.** *There is an increased risk of electric shock if your body is earthed or grounded.*
- Do not expose power tools to rain or wet conditions.** *Water entering a power tool will increase the risk of electric shock.*
- Do not abuse the cord. Never use the cord for carrying, pulling or unplugging the power tool. Keep the cord away from heat, oil, sharp edges or moving parts.** *Damaged or entangled cords increase the risk of electric shock.*
- When operating a power tool outdoors, use an extension cord suitable for outdoor use.** *Use of a cord suitable for outdoor use reduces the risk of electric shock.*

5.1.3 Personal safety

- Stay alert, watch what you are doing and use common sense when operating a power tool. Do not use a power tool while you are tired or under the influence of drugs, alcohol or medication.** *A moment of inattention while operating power tools may result in serious personal injury.*
- Use safety equipment. Always wear eye protection.** *Safety equipment such as dust mask, non-skid safety shoes, hard hat, or hearing protection used for appropriate conditions will reduce personal injuries.*
- Avoid accidental starting. Ensure the switch is in the off position before plugging in.** *Carrying power tools*

with your finger on the switch or plugging in power tools that have the switch on invites accidents.

- Remove any adjusting key or wrench before turning the power tool on.** *A wrench or a key left attached to a rotating part of the power tool may result in personal injury.*
- Do not overreach. Keep proper footing and balance at all times.** *This enables better control of the power tool in unexpected situations.*
- Dress properly. Do not wear loose clothing or jewellery. Keep your hair, clothing and gloves away from moving parts.** *Loose clothes, jewellery or long hair can be caught in moving parts.*
- If devices are provided for the connection of dust extraction and collection facilities, ensure these are connected and properly used.** *Use of these devices can reduce dust related hazards.*

5.1.4 Power tool use and care

- Do not force the power tool. Use the correct power tool for your application.** *The correct power tool will do the job better and safer at the rate for which it was designed.*
- Do not use the power tool if the switch does not turn it on and off.** *Any power tool that cannot be controlled with the switch is dangerous and must be repaired.*
- Disconnect the plug from the power source and/or the battery pack from the power tool before making any adjustments, changing accessories, or storing power tools.** *Such preventive safety measures reduce the risk of starting the power tool accidentally.*
- Store idle power tools out of the reach of children and do not allow persons unfamiliar with the power tool or these instructions to operate the power tool.** *Power tools are dangerous in the hands of untrained users.*
- Maintain power tools. Check for misalignment or binding of moving parts, breakage of parts and any other condition that may affect the power tool's operation. If damaged, have the power tool repaired before use.** *Many accidents are caused by poorly maintained power tools.*
- Keep cutting tools sharp and clean.** *Properly maintained cutting tools with sharp cutting edges are less likely to bind and are easier to control.*
- Use the power tool, accessories and tool bits etc. in accordance with these instructions and in the manner intended for the particular type of power tool, taking into account the working conditions and the work to be performed.** *Use of the power tool for operations different from those intended could result in a hazardous situation.*

5.1.5 Service

- Have your power tool serviced by a qualified repair person using only identical replacement parts.** *This will ensure that the safety of the power tool is maintained.*

5.2 Specific safety rules

- a) **Hold power tools by insulated gripping surfaces when performing an operation where the cutting tool may contact hidden wiring or its own cord. Contact with a “live” wire will make exposed metal parts of the tool “live” and shock the operator.**

-WARNING-

To reduce the risk of injury, user must read instruction manual.

6. Before use



-NOTE-

The voltage provided by the electric supply must correspond to the information given on the type plate on the power tool.

6.1 Using extension cords

- Use only extension cords of a type approved for the application and with conductors of adequate cross section. Failure to observe this point may cause the tool to lose power and the extension cord may overheat. Check the extension cord for damage at regular intervals. Replace damaged extension cords.

6.2 Use of a generator or transformer

This tool may be powered by a generator or transformer which fulfils the following conditions:

- AC voltage, output power at least 2600 W.
- The operating voltage must be within +5 % and –15 % of the rated voltage at all times.
- Frequency range 50–60 Hz; never above 65 Hz.
- Automatic voltage regulation with starting boost.
- Never operate other tools or appliances from the generator or transformer at the same time. Switching other tools or appliances on and off may cause under-voltage and / or overvoltage peaks, resulting in damage to the power tool.

Recommended minimum conductor cross section and max. extension cord lengths:

Mains voltage	Conductor cross section				15 ft extension cord			50 ft extension cord		
					AWG 16	AWG 14	AWG 12	AWG 16	AWG 14	AWG 12
Conductor cross section (mm²)	1.5	2.0	2.5	3.3	1.23	1.95	3.09	1.23	1.95	3.09
100 V	–	30 m	–	50 m	25 ft	75 ft	100 ft	25 ft	50 ft	100 ft
110–120 V	20 m	30 m	40 m	50 m	50 ft	100 ft	150 ft	50 ft	75 ft	125 ft
220–240 V	50 m	–	100 m	–	–	–	–	–	–	–

7. Operation



en

-CAUTION-

Secure the workpiece. Use clamps or a vice to hold the workpiece securely in position. It is then held more safely and both hands remain free for holding and operating the tool.

7.1 Setting forward or reverse rotation 4

The forward / reverse switch is used to set the direction of rotation of the drive spindle. An interlock prevents operation of the switch while the motor is running.

- Push the forward / reverse switch to the left (as seen when the tool is in use) = forwards.
- Push the forward / reverse switch to the right (as seen when the tool is in use) = reverse.

7.2 Switching on / off

1. Plug the supply cord into the power outlet.
2. Press the control switch slowly. This allows the user to select any speed between 0 and maximum.

-NOTE-

The drive spindle begins to rotate only when axial pressure is applied to the tool.

7.3 Lockbutton for sustained operation 5

The lockbutton for sustained operating mode allows continuous operation of the tool without need for applying constant pressure to the control switch.

7.3.1 Switching on in sustained operating mode

1. Press the control switch as far as it will go and hold it in this position.
2. Press the lockbutton and then release the control switch.

7.3.2 Switching off after sustained operation

3. Press the control switch. The lockbutton returns to its original position.

7.4 Interface for insert tools and accessories 6

1. Unplug the supply cord from the power outlet.
2. The depth gauge can be removed simply by pulling it away from the tool (click connection). The drive spindle is then exposed. The drive spindle must be exposed (depth gauge removed) for the following operations:
 - Using the tool to remove screws (reverse rotation)
 - Changing bits
 - Changing the bit holder
 - Attaching the SMI 55 Plus magazine
 - Tightening / re-driving existing screws

7.5 Adjusting the depth gauge 7

-NOTE-

By adjusting the depth gauge, the screw can be driven flush with the surface or left projecting. Each click-stop equals an adjustment of ± 0.25 mm (see illustration).

7.5.1 To drive the screw deeper

1. Turn the depth gauge to the right.

7.5.2 To drive the screw less deeply

2. Turn the depth gauge to the left.

7.6 Removing the depth gauge 6

1. Pull the depth gauge forward, away from the tool.

7.7 Changing insert tools 8

The chuck for holding insert tools (bit holder, bits etc.) is of the standard (DIN 3126 / ISO 1173) $1/4$ " hex. socket type. The screwdriving insert tools are held in place by a spring mechanism.

1. Unplug the supply cord from the power outlet.
2. Remove the depth gauge by pulling it forward, away from the tool.
3. The insert tool can then be pulled out and changed (longer bit, bit holder, etc.).
4. Refit the depth gauge to the tool.

7.8 Removing a screw 9

Remove the depth gauge by pulling it forward, away from the tool.

Set the forward / reverse switch to the reverse rotation position.

The screw can then be removed.

7.9 Fitting / removing the belt hook

7.9.1 Fitting the belt hook 2

1. Insert the belt hook mounting lug in the ventilation slot on the tool.
2. Push the belt hook forward (toward the chuck).
3. Secure the belt hook with the retaining screw.

7.9.2 Removing the belt hook 3

1. Release the belt hook by removing the retaining screw.
2. Slide the belt hook back.
3. Pull the belt hook upwards out of the ventilation slot.

8. Care and maintenance

Unplug the supply cord from the power outlet.

8.1 Care of screwdriving bits and metal parts

Clean off dirt and dust deposits adhering to the surface of the screwdriving bits, chuck or spindle and protect these parts from corrosion by wiping them from time to time with an oil-soaked rag.

8.2 Care of the power tool

The outer casing of the tool is made from impact-resistant plastic. Sections of the grip are made from a synthetic rubber material.

Never operate the power tool when the ventilation slots are blocked. Clean the ventilation slots carefully using a dry brush. Do not permit foreign objects to enter the interior of the power tool. Clean the outside of the power tool at regular intervals using a slightly damp cloth. Do not use a spray, steam pressure cleaning equipment or

running water for cleaning. This may negatively affect the electrical safety of the power tool. Always keep the grip surfaces of the power tool free from oil and grease. Do not use cleaning agents which contain silicone.

8.3 Maintenance

Check all external parts of the power tool for damage at regular intervals and check that all controls operate faultlessly. Do not operate the power tool if parts are damaged or when the controls do not function faultlessly. If necessary, your power tool should be repaired at a Hilti repair center.

Repairs to the electrical section of the power tool may be carried out only by trained electrical specialists.

8.4 Checks after care and maintenance

After carrying out care and maintenance, check the power tool for correct operation (drive and remove a screw).

en

9. Disposal



Most of the materials from which Hilti power tools are manufactured can be recycled. The materials must be correctly separated before they can be recycled. In many countries, Hilti has already made arrangements for taking back your old power tools for recycling. Please ask your Hilti customer service department or Hilti representative for further information.

10. Manufacturer's warranty – tools

Hilti warrants that the tool supplied is free of defects in material and workmanship. This warranty is valid so long as the tool is operated and handled correctly, cleaned and serviced properly and in accordance with the Hilti Operating Instructions, and the technical system is maintained. This means that only original Hilti consumables, components and spare parts may be used in the tool.

This warranty provides the free-of-charge repair or replacement of defective parts only over the entire lifespan of the tool. Parts requiring repair or replacement as a result of normal wear and tear are not covered by this warranty.

Additional claims are excluded, unless stringent national rules prohibit such exclusion. In particular,

Hilti is not obligated for direct, indirect, incidental or consequential damages, losses or expenses in connection with, or by reason of, the use of, or inability to use the tool for any purpose. Implied warranties of merchantability or fitness for a particular purpose are specifically excluded.

For repair or replacement, send tool or related parts immediately upon discovery of the defect to the address of the local Hilti marketing organization provided.

This constitutes Hilti's entire obligation with regard to warranty and supersedes all prior or contemporaneous comments and oral or written agreements concerning warranties.

UL listed to US and Canadian safety standards
Homologué UL (conforme aux normes de sécurité américaines et canadiennes)
Producto homologado según normas de seguridad americanas y canadienses
Produto homologado de acordo com as normas de segurança americanas e canadianas





Hilti Corporation

FL-9494 Schaan

Tel.: +423 / 234 21 11

Fax: +423 / 234 29 65

www.hilti.com

285702 / B