

## QUICK SPECS

Weight (Cabin)	8,214 lbs
Horsepower	24.4 HP
Max Dig Depth	11'3"

**Power, flexibility and stability in a compact package.**

YANMAR's ViO35-6A, our 3.5-ton class mini excavator, is powered by a 24.4 HP Tier 4 Final YANMAR engine. It raises the bar with 20 percent less fuel consumption and with operator comfort for the long hours at jobsites. With true zero tail swing, it allows you to be more productive while working on construction, utility and landscaping applications. Plus, YANMAR's unique SmartAssist Remote gives you peace of mind with theft prevention and maintenance management tools as well as other remote monitoring services.



## ViO35-6A

**POWERFUL, EFFICIENT, ELECTRONICALLY CONTROLLED 24.4 HP TIER 4 FINAL YANMAR DIESEL ENGINE**

**ECO & AUTO-DECEL MODE STANDARD**

**JOYSTICK PILOT CONTROLS WITH CONTROL PATTERN STANDARD**

**AUXILIARY HYDRAULICS WITH PROPORTIONAL CONTROL STANDARD**

**2-SPEED DRIVE CONTROL STANDARD**

**OPTIONAL ENCLOSED CAB WITH HEAT AND A/C**

**OPTIONAL ANGLE BLADE AVAILABLE**

**RUBBER TRACKS STANDARD; STEEL TRACKS OPTIONAL**

## INNOVATIVE FEATURES



### Advanced Operation Control System

The digital control system allows you to monitor up to three months of operational history. Because this state-of-the-art system centralizes control of machine operation information and maintenance support information, it's never been easier to maintain a timely, efficient service process.



### Easier To Service Than Your Car

The innovative design puts virtually every major component – engine, hydraulic system, starter, alternator, battery – right at your fingertips. Because routine filter and grease fitting checks are easier and quicker, you can perform them more often, extending the life of and improving the durability of your machine.



### YANMAR's Patented Quick Coupler System

The standard hydraulic Quick Coupler makes changing buckets fast and easy. With the exception of fitting and removing the safety lock pin, the entire operation is performed electronically while you're seated in the comfort of the cab. Less hassle, less downtime, more productivity!



# Vi035-6A

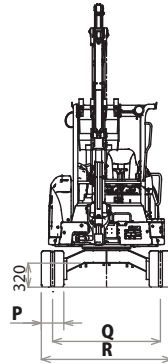
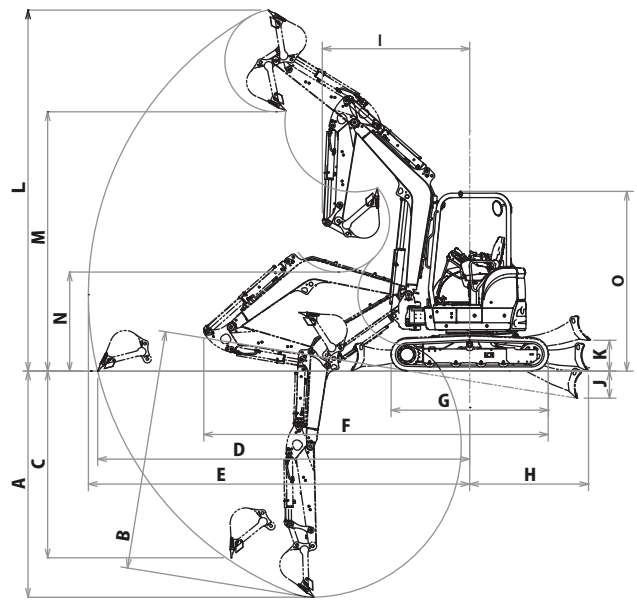
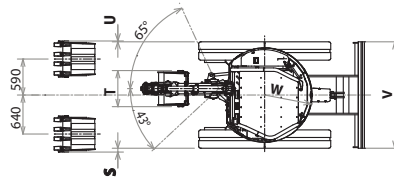

## Dimensions - Vi035-6A

<b>A</b> 10 ft. 8 in. (3,250 mm)	<b>L</b> 16 ft. 9 in. (5,110 mm)
<b>B</b> 11 ft. 3 in. (3,440 mm)	<b>M</b> 11 ft. 2 in. (3,410 mm)
<b>C</b> 7 ft. 11 in. (2,410 mm)	<b>N</b> 4 ft. 1 in. (1,240 mm)
<b>D</b> 17 ft. 3 in. (5,270 mm)	<b>O</b> 8 ft. 1 in. (2,470 mm)
<b>E</b> 17 ft. 8 in. (5,390 mm)	<b>P</b> 1 ft. (300 mm)
<b>F</b> 15 ft. 8 in. (4,770 mm)	<b>Q</b> 4 ft. 9 in. (1,440 mm)
<b>G</b> 7 ft. 1 in. (2,160 mm)	<b>R</b> 5 ft. 9 in. (1,740 mm)
<b>H</b> 5 ft. 4 in. (1,630 mm)	<b>S</b> 2.6 in. (65 mm)
<b>I</b> 7 ft. 1 in. (2,170 mm)	<b>T</b> 1 ft. 11 in. (590 mm)
<b>J</b> 1 ft. 3 in. (370 mm)	<b>U</b> 0.6 in. (15 mm)
<b>K</b> 1 ft. 5 in. (425 mm)	<b>V</b> 5 ft. 9 in. (1,740 mm)
	<b>W</b> 2 ft. 7 in. (775 mm)

## Specifications

Model		Vi035-6A	
Type		Canopy	Cabin
<b>Operating Weight</b>	Rubber track	lbs (t)	7,905 (3.58)
	Steel track	lbs (t)	8,125 (3.68)
<b>Engine</b>	Type	Water-cooled 4-cycle diesel	
	Model	3TNV88F-ESBV	
	Rated Output	HP (kW)/rpm	24.4 (18.2) / 2,200
<b>Performance</b>	Max Digging Force, Bucket / Arm	lbs (kN)	7,216 (32.1)* / 4,586 (20.4)*
	Traveling Speed, High / Low	MPH (km / h)	2.7 (4.5) / 1.6 (2.7)
	Swing Speed	RPM	9.5
	Boom Swing Angle, (L / R)	degrees	43 / 65
<b>Ground Contact Pressure (Rubber Track)</b>		PSI (kPa)	4.80 (33.1)   4.97 (34.3)
<b>Hydraulic System</b>	Pump Capacity	GPM (L / min)	9.8 (37.0) x 2 <Variable displacement pump> 6.9 (26.2) x 1, 2.9 (10.8) x 1 <Gear pump>
	Main Relief Set Pressure	PSI (MPa)	3,205 (22.1) x 2, 3,133 (21.6) x 1
<b>Blade Dimensions</b>	Width	ft-in (mm)	5' 8" (1,740)
	Stroke, Raise / Lower from G.L.	ft-in (mm)	1' 5" (425) / 1' 3" (370)
<b>Fuel tank capacity</b>		Gals (L)	10.8 (41)

\*without quick coupler

## Standard Equipment

- Hydraulic Quick Coupler\*
- Backfill Dozer Blade
- Boom Swing Function
- Rubber Tracks
- Arm End Auxiliary Valve
- Back Mirror
- 2-way Pattern Control
- ROPS / FOPS Canopy, Cabin
- Windshield Washer
- Joystick Pilot Controls
- Arm Rests (Adjustable)
- Suspension and Reclining Seat
- Seat Belt
- Proportional Auxiliary Hydraulics Control
- Dual Speed Switch
- Auto Deceleration Switch
- Eco Mode Switch
- Engine Stop Switch
- Traveling Alarm
- Floor Mats

\*Also available without Quick Coupler.

Please note that the standard equipment may vary from this list. Consult your Yanmar dealer for confirmation.

## Hydraulic PTO

Model	Vi035-6A		
	Output	PSI (MPa)	GPM (L / min)
			2,200RPM
<b>Combined Flow, Double Actions</b>	3,205 (22.1)	16.7 (63.2)	8.35 (31.6)

## Lifting Capacity

LIFT POINT HEIGHT h:in (mm)	r:REACH in (mm)											
	RATED LIFT CAPACITY OVER END BLADE DOWN				RATED LIFT CAPACITY OVER END BLADE UP				RATED LIFT CAPACITY OVER SIDE BLADE UP			
	MAX	137.8(3,500)	118.1(3,000)	98.5(2,500)	MAX	137.8(3,500)	118.1(3,000)	98.5(2,500)	MAX	137.8(3,500)	118.1(3,000)	98.5(2,500)
118.1 (3,000)	1,719(780)	1,631(740)	1,609(730)		1,058(480)	1,322(600)	1,565(710)		992(450)	1,278(580)	1,565(710)	
78.7 (2,000)	1,763(800)	1,918(870)	2,138(970)	2,491(1,130)	903(410)	1,278(580)	1,653(750)	2,447(1,110)	815(370)	1,256(570)	1,543(700)	2,447(1,110)
39.4 (1,000)	1,807(820)	2,336(1,060)	2,888(1,310)	3,813(1,730)	793(360)	1,190(540)	1,521(690)	1,984(900)	749(340)	1,124(510)	1,410(640)	1,807(820)
Ground (0)	1,873(850)	2,601(1,180)	3,218(1,460)	4,012(1,820)	815(370)	1,124(510)	1,410(640)	1,873(850)	793(360)	1,058(480)	1,322(600)	1,719(780)
-39.4 (-1,000)	1,940(880)	2,403(1,090)	2,954(1,340)	3,703(1,680)	925(420)	1,080(490)	1,388(630)	1,851(840)	881(400)	1,014(460)	1,322(600)	1,675(760)
-59.1 (-1,500)	1,918(870)	2,050(930)	2,579(1,170)	3,130(1,420)	1,124(510)	1,080(490)	1,410(640)	1,851(840)	1,058(480)	1,058(480)	1,344(610)	1,675(760)
-78.7 (-2,000)	1,851(840)				1,477(670)				1,410(640)			