

N O V O L I N K

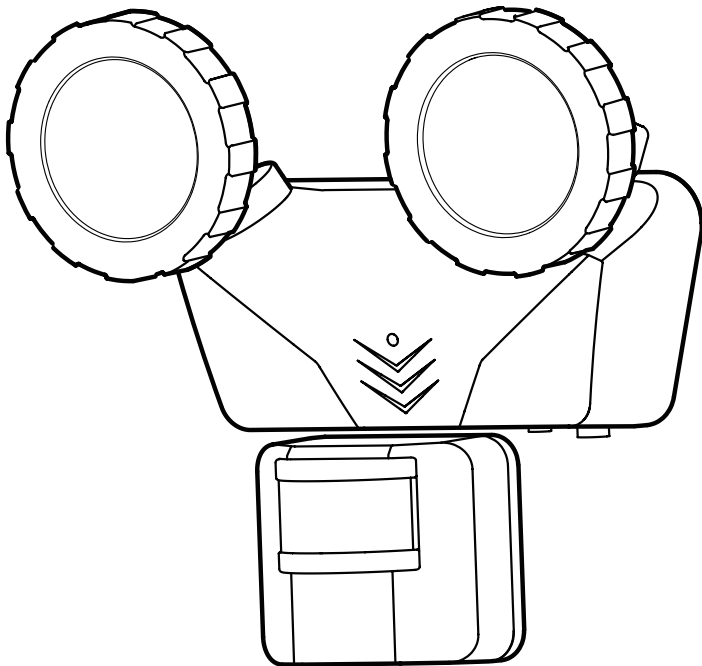

N L - D S W 2 / D S G 2 I N S T R U C T I O N M A N U A L

Questions, problems, missing parts?
We're ready to help. Call Novolink Customer Service
9 a.m. - 5 p.m., Monday-Friday

1-800-933-7188

NOVOLINKINC.COM

We appreciate the trust and confidence you have placed in Novolink through the purchase of this solar motion light. We strive to continually create quality products designed to enhance your home. Visit us online to see our full line of products available for your home improvement needs. Thank you for choosing Novolink!

TABLE OF CONTENTS

1-Year Warranty	2
Tools and Hardware	3
Main Package Contents	4
Planning Installation	5
Installing the Solar Panel	6
Installing the Motion Light	8
Connecting the Solar Panel to the Motion Light	10
Charging and Replacing the Battery	11
Operation	13
Maintenance, Cleaning and Care	15
Troubleshooting	16

SAFETY INFORMATION

This manual has been carefully designed and organized to make the assembly, operation, and continued maintenance of the product as easy and safe as possible, provided it is installed, operated, maintained, and tested in strict accordance with the instructions and warnings contained in this manual. Read and follow all guidelines and operating instructions before the first use of this product. Store the manual in a safe, easily accessible location.

WARNINGS



When selecting a replacement battery, ensure the correct battery type is chosen.

Keep these instructions safe for future reference.

Do not make any additions to the wiring of the LED Solar Motion Light.

Always take precautions if using a step ladder when installing the LED Solar Motion Light.

1-YEAR WARRANTY: WHAT IS COVERED



The manufacturer warrants to the original purchaser that the products delivered are free of defects in material and workmanship for the period listed below from the date of purchase.

The manufacturer requires a proof of purchase for any warranty claim. The warranty is conditioned on the following:

1. The manufacturer must be notified within the period of the warranty from the date purchased and have been given the opportunity of inspection by return of any alleged defective product.
2. The product must not have been abused, misused or improperly maintained, installed or repaired during the warranty period.
3. Such alleged defects should not be deemed as a result of any circumstance not falling under ordinary 'wear and tear'. The manufacturer makes no other warranty or representation either expressed or implied.
4. The manufacturer's maximum liability is limited to the purchased price of the product. In no event shall the manufacturer be liable for any consequential, indirect, incidental, or special damages of any nature arising from the sale or use of this product.

Contact Novolink Customer Service
1-800-933-7188
or visit www.novolinkinc.com

TOOLS AND HARDWARE

TOOLS REQUIRED

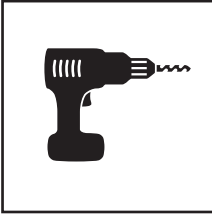

Power Drill

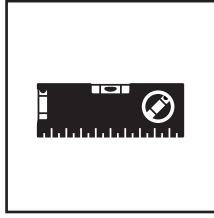

Level

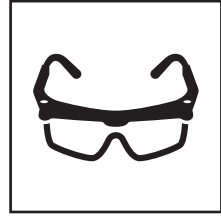

Safety Goggles

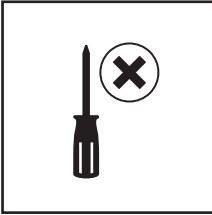

Phillips Screwdriver

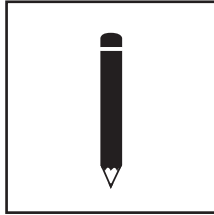

Pencil

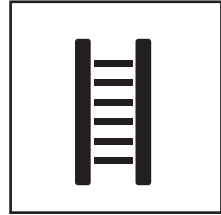

Ladder

HARDWARE NEEDED

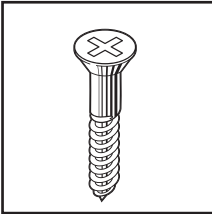

AA

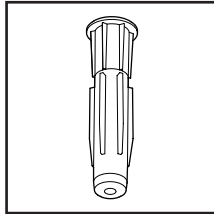

BB

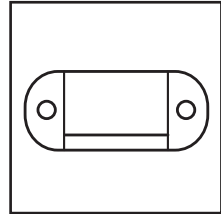

CC

PART	DESCRIPTION	QUANTITY
AA	Screws	6
BB	Plugs	6
CC	Quick-Clip mounting bracket	1

MAIN PACKAGE CONTENTS

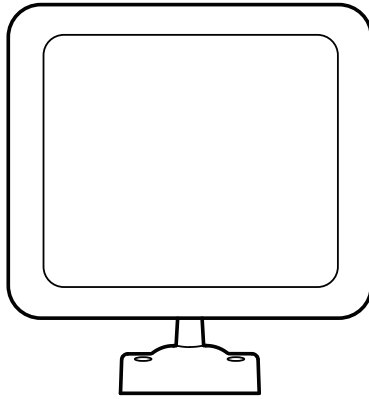
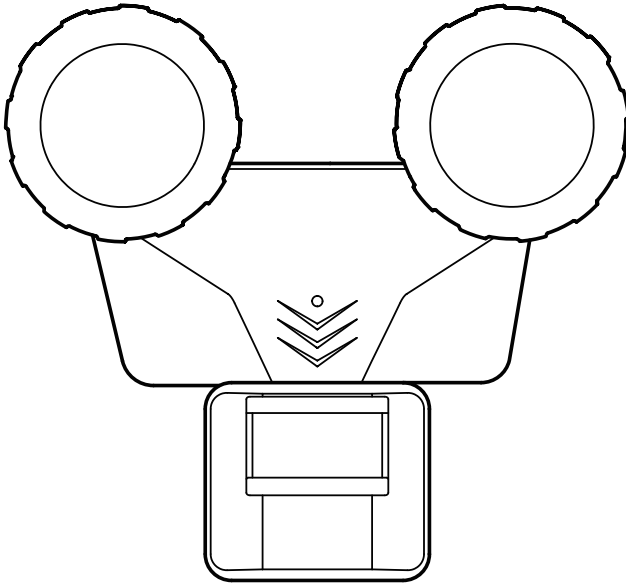

PART	DESCRIPTION	QUANTITY
A	Dual Head LED Motion Light	1
B	Solar Panel with Wire	1

PLANNING INSTALLATION

For the best result, locate the solar panel in a position where it receives direct sunlight and is generally free from cover and shade.

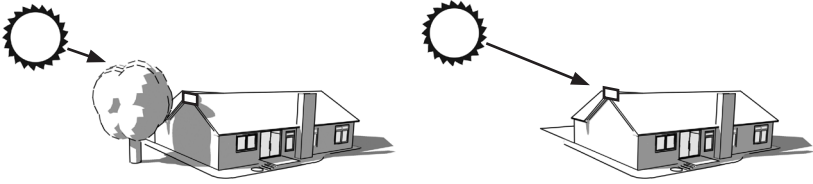

Be aware and consider foliage and building overhangs, which will affect the solar panel's ability to charge.

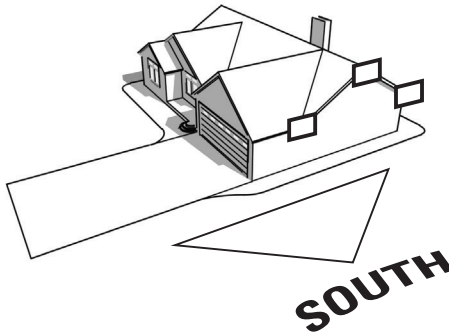

NOTE: Face the solar panel due south for maximum sun exposure.

Select an area where the Motion Light and Solar Panel can be mounted with ease. Consider that the units must be within 15 feet (the length of the power cable from the Solar Panel) to be connected.

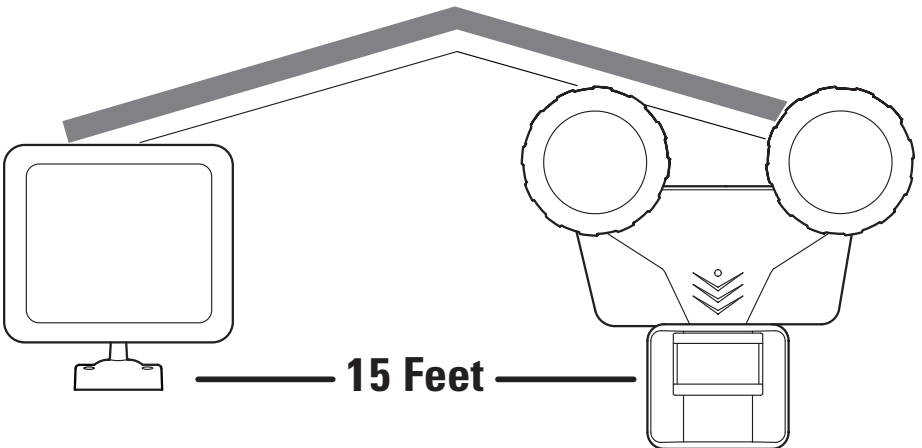

INSTALLING THE SOLAR PANEL

1. Place the solar panel mounting bracket on the desired wall.
2. Mark with a pencil, the four pre-drilled holes in the mounting bracket on the wall.

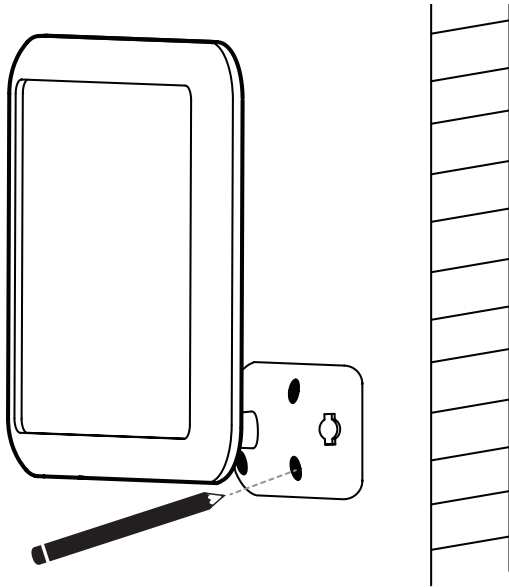

3. Utilize a standard power drill to create the mounting holes.

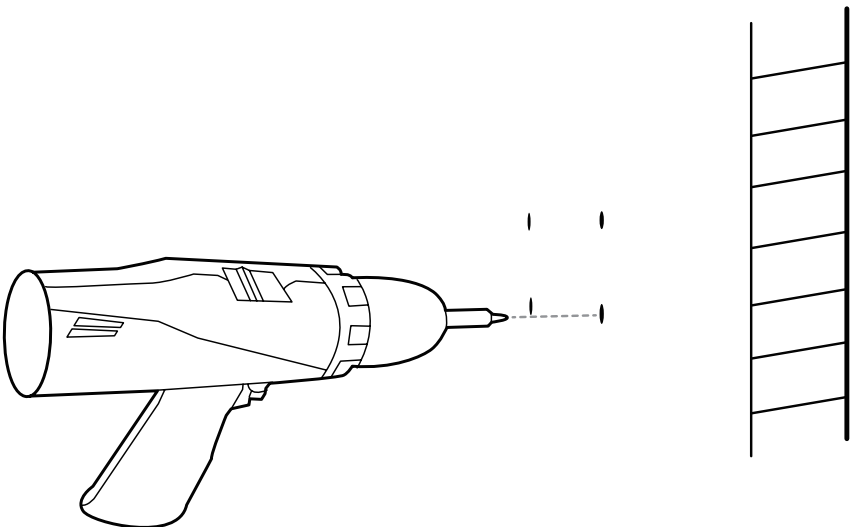

-
4. Place four plugs (BB) in the mounting holes.
 5. Place the solar panel mounting bracket (B) over the four plugs (BB).
 6. Use a Phillips screwdriver to screw in the four screws (AA) into the pre-drilled holes of the mounting bracket.

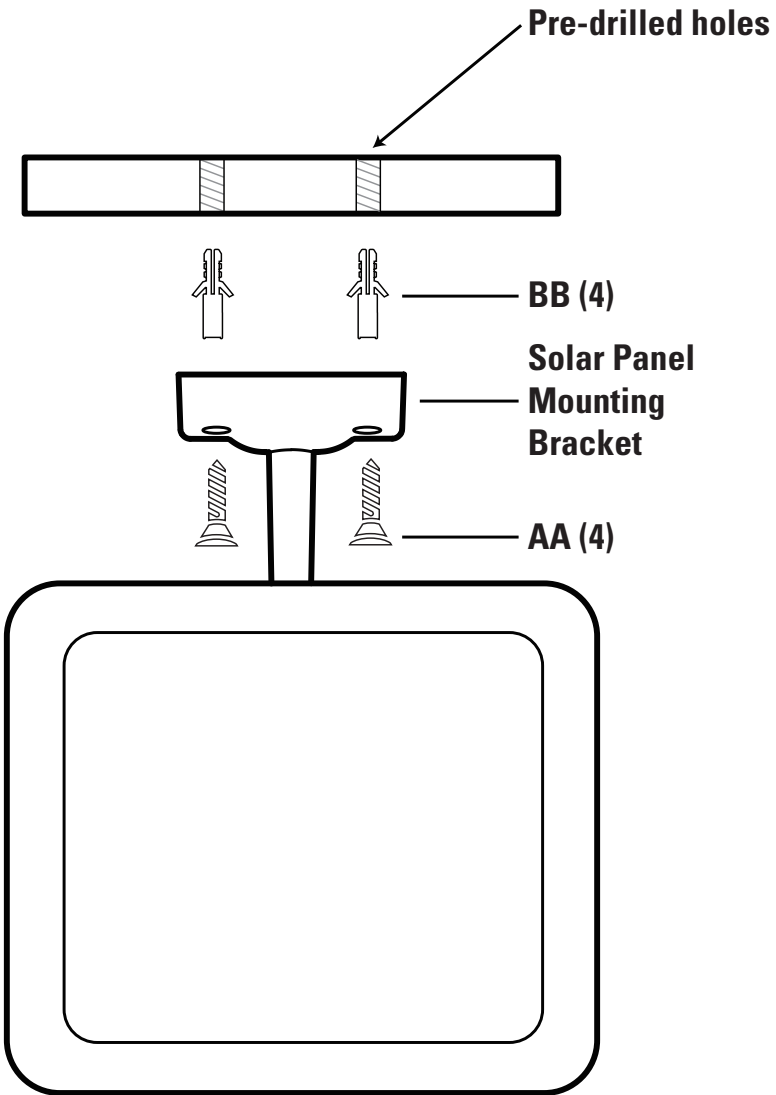

INSTALLING THE MOTION LIGHT

Place the Quick-Clip mounting bracket (CC) on the desired wall.

1. Mark with a pencil, the two pre-drilled holes in the mounting bracket on the wall.

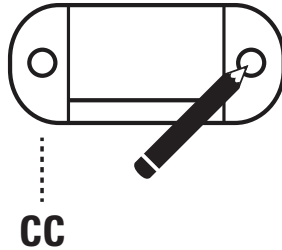

2. Utilize a standard power drill to create the mounting holes.
3. Place two plugs (BB) in the mounting holes.
4. Place two plugs (BB) in the mounting holes.
5. Place the Quick-Clip mounting bracket (CC) over the two plugs (BB).
6. Use a Phillips screwdriver to screw in the two screws (AA) into the pre-drilled holes of the Quick-Clip mounting bracket.

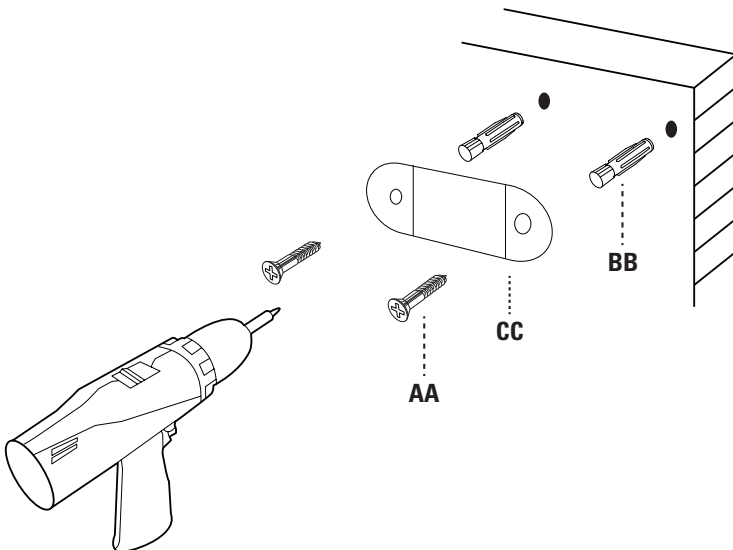

NOTE: The beveled side of the Quick-Clip mounting bracket should be facing downwards and the flat side should be facing outwards.

INSTALLING THE MOTION LIGHT

1. Once the Quick-Clip mounting bracket (CC) is installed, ensure all the screws are tightly fastened. The LED Motion Light is now ready to be positioned into place.
2. Place the light hook (pre-installed on the back of the light) over the mounting bracket. At this point, a click will be heard as the light secures into place.

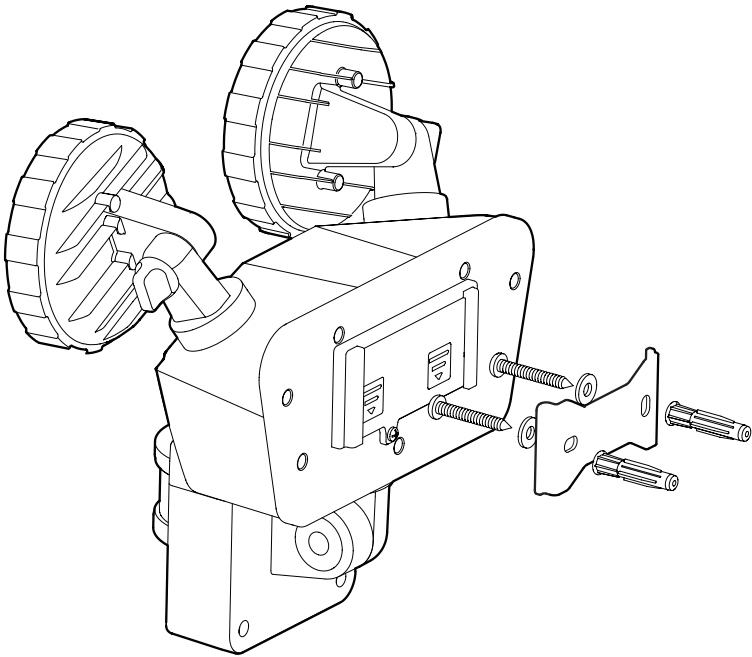

CONNECTING THE SOLAR PANEL TO THE MOTION LIGHT

1. Insert the wire plug from the solar panel to the motion light socket located underneath the battery housing.
2. The LED Solar Motion Light is now installed and ready to charge.

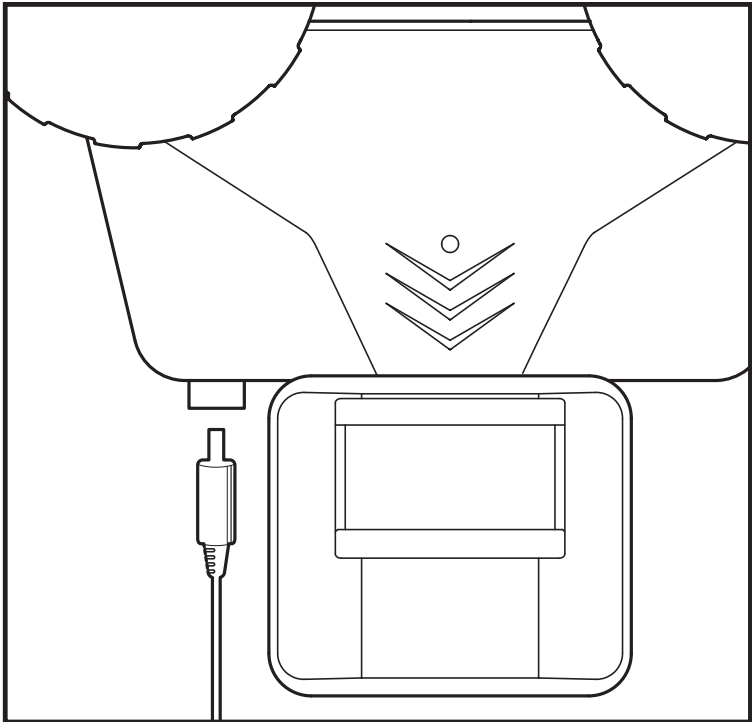
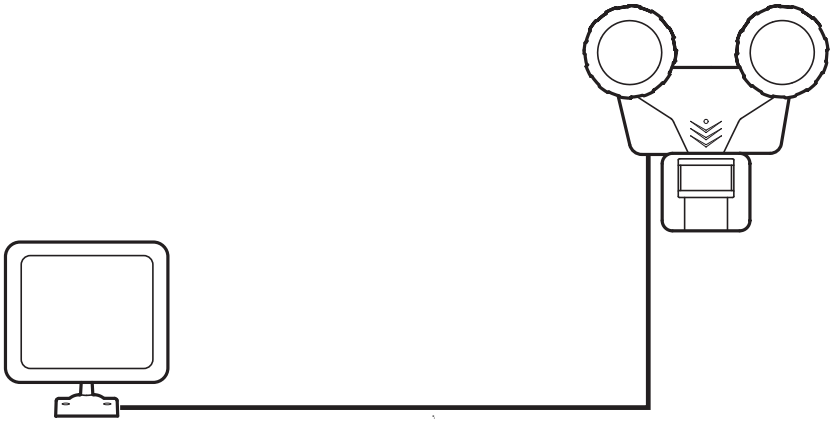

CHARGING AND REPLACING THE BATTERY

Before Use

Before the LED Solar Motion Light can operate to its full capacity, the solar panel needs to be in sunlight for 3 days to fully charge the included battery. Charge the unit in the “OFF” position.

Once Charged

The Motion Light will charge automatically everyday, as long as the Solar Panel is exposed to direct sunlight. Insure that there are no obstructions that place the Solar Panel in a shaded area.

On days that have reduced sunlight, or in some geographical areas that do not have regular sunlight exposure, the battery may take longer to charge, or may not charge at all. Contact a Customer Service Representative, or review the Troubleshooting section if the Motion Light is not powered.

Replacing the Battery

Insure that the battery is not charging before replacing the battery pack. The battery pack is located in back of the light’s battery housing.

1. Turn the switch to the “OFF” position. Remove the four screws from the battery housing.

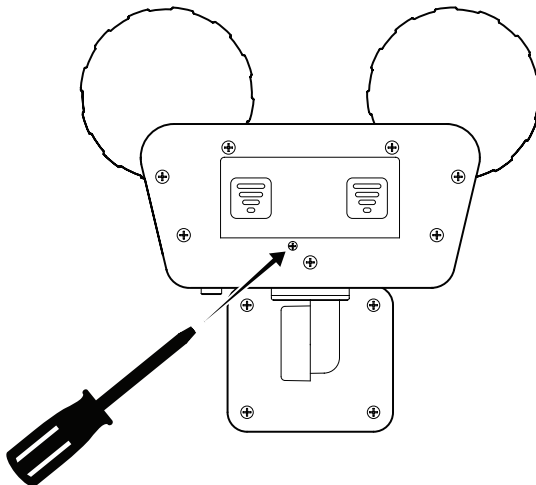

-
2. Separate the battery pack connector. Remove the old battery pack and replace it with a new identical rechargeable battery pack.

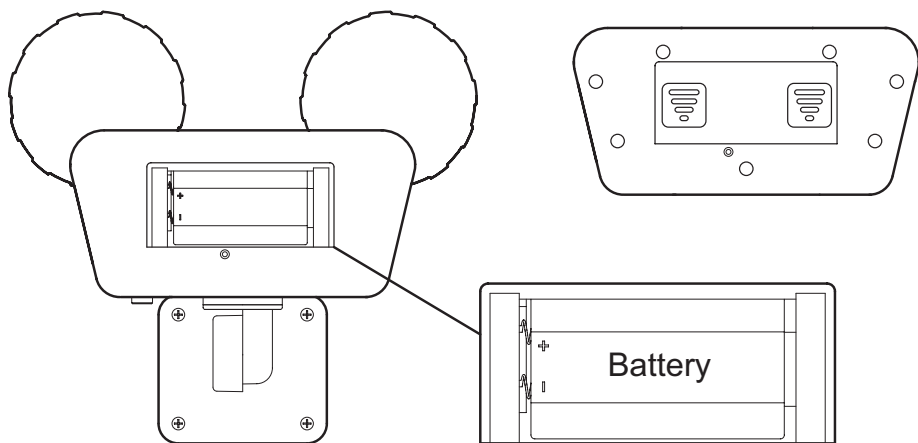

3. Replace the cover of the battery housing and secure it with the four screws.

NOTE: Please contact Novolink for battery replacement information.

OPERATION

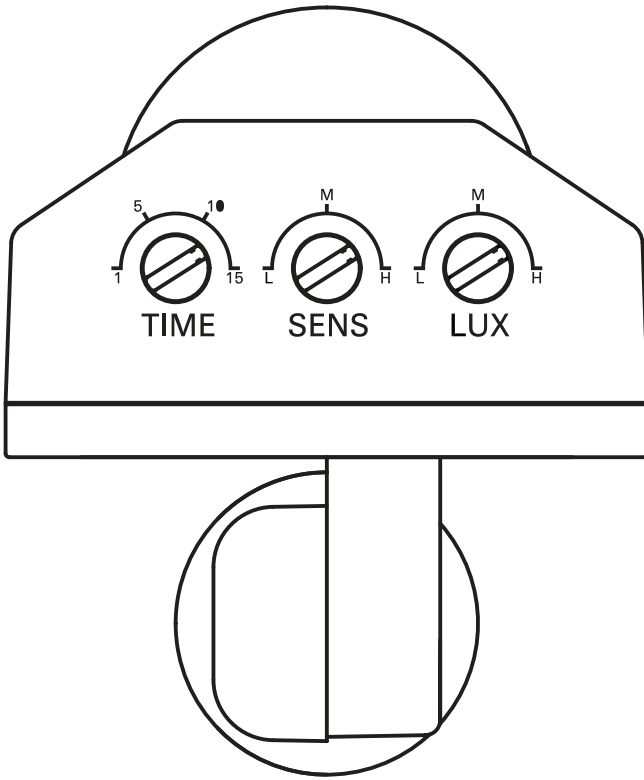

OFF/AUTO Switch: Light will turn on when motion is detected at nighttime only. If the battery has limited power, the unit will automatically go into ECO mode, where in the light will reduce brightness in order to conserve battery power.

Adjustable features:

- **Time Delay (TIME):** Adjusts the amount of time the light will stay on after triggering, from 1 minute up to 15 minutes
- **Sensitivity (SENS):** Adjusts the sensitivity of the motion sensor. Low, Medium and High settings.
- **LUX:** Compensates for ambient light sources that may affect proper operation of the unit, especially the Dusk-to-Dawn feature.v

MAINTENANCE, CLEANING AND CARE

- Periodically check the connection from the solar panel to the light. Ensure this plug is correctly inserted.
- Some seasonal adjustment of the solar panel may be required to offset shorter charge days during the winter.
- Ensure the solar panel is free from any obstruction such as trees or buildings.
- The solar panel should be cleaned on a regular basis. This will ensure the LED Solar Motion light charges consistently.
- To clean the solar panel, use a damp cotton cloth. Never use any abrasive materials or cleaning products.
- The lens of the LED light should also be cleaned with a damp cotton cloth. This ensures a clear illumination.

TROUBLESHOOTING

Problem	Solution
Where should the solar panel be mounted?	Mount the solar panel in a position that will enable the maximum amount of light to be absorbed. In the Northern Hemisphere this is usually south facing.
Does the solar panel require direct sun to charge?	The solar panel can charge the internal battery in direct and indirect light. For best results, place the panel in direct light to maximize and increase efficiency.
Can additional or extended cable wire for the LED Solar Motion Light be purchased?	At this point there are no extensions available for the cable that connects the light to the solar panel. Any additions to the cable will void the warranty.
Why does the LED Solar Motion Light not illuminate at night?	Log into the App and check the battery status of the unit. If the battery is low, then allow it to fully charge before using the light. If the battery is charged, adjust the LUX in the light's Settings menu.
Where can a new battery for the LED Solar Motion Light be purchased?	Please contact www.novolinkinc.com or call 1-800-933-7188.
Are any parts of the LED Solar Motion Light weatherproof?	All parts of the LED Solar Motion Light are fully weather-proofed and are ideal for any exterior installation.
Why does the LED Solar Motion Light appear to 'strobe' or flash?	Log into the App and check the battery status of the unit. If the battery is low, then allow it to fully charge before using the light. If the battery is charged, adjust the LUX in the light's Settings menu.
Will decorative or street lights have an effect on the LED Solar Motion Light's ability to operate?	Yes, the sensor of the LED Solar Motion Light is light sensitive. For nighttime usage, ensure no other light activates the motion sensor.

Questions, problems, missing parts?
We're ready to help. Call Novolink Customer Service
9 a.m. - 5 p.m., Monday-Friday

1-800-933-7188

NOVOLINKINC.COM