

# OWNER'S MANUAL



**Flavor Pro™**

**Model #7400**



**PATENTED  
& PATENTS PENDING**

**Keep your receipt with  
this manual for warranty.**

**CUSTOMER SERVICE  
1-912-638-4724  
Service@CharGriller.com**

Contents of this manual are Trademarked and Copyrighted by Char-Griller | A&J Manufacturing.  
Using the information contained in this manual without consent of Char-Griller and/or A&J  
Manufacturing is strictly prohibited.



# TABLE OF CONTENTS

Safety Warnings & Warranty.....	A-1
Assembly Instructions .....	B-1
Product Usage .....	C-1
Recipes .....	D-1
Accessories .....	E-1



## Danger

If you smell gas:

1. Shut off gas to the appliance.
2. Extinguish any open flame.
3. If odor continues, keep away from the appliance and immediately call your gas supplier or your fire department.



## Warning

1. Do not store or use gasoline or other flammable liquids or vapors in the vicinity of this or any other appliance.
2. An LP cylinder not connected for use shall not be stored in the vicinity of this or any other appliance.



## Warning

For Outdoor Use Only (outside any enclosure).

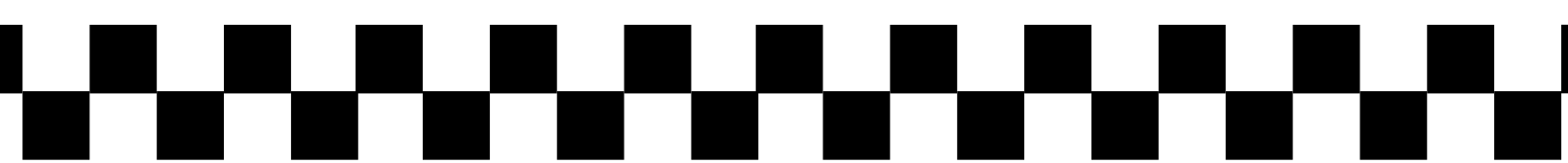



# IMPORTANT SAFETY WARNINGS

**A propane gas cylinder is required for operation. This gas grill is not intended for commercial use.**

**SAVE THESE INSTRUCTIONS FOR FUTURE REFERENCE. IF YOU ARE ASSEMBLING THIS UNIT FOR SOMEONE ELSE, GIVE THIS MANUAL TO HIM OR HER TO SAVE FOR FUTURE REFERENCE.**

**For use outdoors and in well-ventilated areas, only.**

## **WARNING:**

Improper installation, adjustment, alteration, service, or maintenance could cause injury or property damage. Read the installation, operation, and maintenance instructions thoroughly before assembling or servicing this equipment. Failure to follow these instructions could result in fire or explosion that could cause property damage, personal injury, or death.

## **DANGER:**

DO NOT use gas grill for indoor cooking or heating. TOXIC fumes can accumulate and cause asphyxiation. Do not use in or on boats or recreational vehicles.

## **WARNING:**

Accessible parts may be very hot. Keep young children away. Read the instruction literature before using the appliance. The use of unauthorized parts can create unsafe conditions and environment.

**NOTE:** The use and installation of this product must conform to local codes or, in absence of local codes, the Natural Gas and Propane Installation Code, CSA B149.1, or the Propane Storage and Handling Code, CSA B149.2.

**IMPORTANT NOTICE:** Read all instructions prior to assembly and use. Read and understand all warnings and precautions prior to operating your grill.

## **READ ALL SAFETY WARNINGS AND INSTRUCTIONS CAREFULLY BEFORE ASSEMBLING AND OPERATING YOUR GRILL**



**WARNING:** FUELS USED IN LIQUEFIED PROPANE GAS APPLIANCES, AND THE PRODUCTS OF COMBUSTION OF SUCH FUELS, CAN EXPOSE YOU TO CHEMICALS INCLUDING BENZENE, WHICH IS KNOWN TO THE STATE OF CALIFORNIA TO CAUSE CANCER AND CAUSE BIRTH DEFECTS OR OTHER REPRODUCTIVE HARM. *For more information go to: [www.P65Warnings.ca.gov](http://www.P65Warnings.ca.gov).*

**ADVERTENCIA:** LOS COMBUSTIBLES USADOS EN EQUIPOS PARA LICUAR GAS PROPANO, ASÍ COMO LOS PRODUCTOS DE SU COMBUSTIÓN, PUEDEN EXPONERTE A SUSTANCIAS QUÍMICAS, ENTRE ELLAS EL BENCENO, QUE EL ESTADO DE CALIFORNIA RECONOCE COMO CAUSA DE CÁNCER Y DE MALFORMACIONES CONGÉNITAS Y OTROS DAÑOS AL SISTEMA REPRODUCTOR. *Para más información, visite [www.P65Warnings.ca.gov](http://www.P65Warnings.ca.gov)*



**WARNING:** FUELS USED IN WOOD OR CHARCOAL BURNING APPLIANCES, AND THE PRODUCTS OF COMBUSTION OF SUCH FUELS, CAN EXPOSE YOU TO CHEMICALS INCLUDING CARBON BLACK, WHICH IS KNOWN TO THE STATE OF CALIFORNIA TO CAUSE CANCER, AND CARBON MONOXIDE, WHICH IS KNOWN TO THE STATE OF CALIFORNIA TO CAUSE BIRTH DEFECTS OR OTHER REPRODUCTIVE HARM. *For more information go to: [www.P65Warnings.ca.gov](http://www.P65Warnings.ca.gov).*

**ADVERTENCIA:** LOS COMBUSTIBLES USADOS EN EQUIPOS PARA QUEMAR MADERA O CARBÓN, ASÍ COMO LOS PRODUCTOS DE TAL COMBUSTIÓN, PUEDEN EXPONERTE A SUSTANCIAS QUÍMICAS, ENTRE ELLAS EL NEGRO DE HUMO Y EL MONÓXIDO DE CARBONO, QUE EL ESTADO DE CALIFORNIA RECONOCE COMO CAUSA, RESPECTIVAMENTE, DE CÁNCER Y DE MALFORMACIONES CONGÉNITAS Y OTROS DAÑOS AL SISTEMA REPRODUCTOR. *Para más información, visite [www.P65Warnings.ca.gov](http://www.P65Warnings.ca.gov)*



Read the following instructions carefully and be sure your barbecue is properly assembled, installed and maintained. Failure to follow these instructions may result in serious bodily injury and/or property damage. If you have any questions concerning assembly or operation, consult your dealer or LP gas company.

- When used, always place the appliance and gas bottle on flat level ground. Grill can be used with 20lb gas cylinder. Grill will perform better if propane or LPG mixtures are used. Butane can be used, but because of the rate of the appliance the cylinder will tend to freeze and supply gas at reduced pressures, affecting grill performance.
- DO NOT move the appliance during use.
- DO NOT attempt to disconnect any gas fittings while barbecue is in use.
- DO NOT use gas bottle if the bottle and/or valve are damaged, rusty, or dented as this may be hazardous. Contact your supplier to have it checked.
- DO NOT lean over an open grill and be mindful of hands/fingers near the edge of the cooking area.
- Should a fire occur, turn off all gas burners, close the lid, and stand back from grill until fire is out.
- Should flames go out while in operation, turn off all gas valves and leave lid open. Return to grill after five minutes and try to relight the burners – following lighting instructions.
- Keep children and pets away from grill when in use. Some parts of the grill will become very hot.
- When cleaning the valves and burners, be careful not to stretch the valve orifices or burner ports.
- Move gas hoses as far away as possible from hot surfaces and dripping hot grease.
- Gas may still be present in a cylinder that appears to be empty. Adhere to proper transportation/storage of the cylinder at all times.
- If gas is leaking from cylinder, move away from cylinder immediately and call your gas supplier or fire department. DO NOT try to address problem yourself.
- DO NOT use a flame to check for gas leaks.
- DO check for gas leaks and any obstructions to burners before use. This is especially important after a period of storage or non-use.
- The flexible tube should be changed whenever it is damaged or cracked or by expiration date printed on the tubing. Or, change tube every five (5) years.
- Always connect or replace cylinder in a well-ventilated area, and never in the presence of a flame, spark or heat source.
- Grill must be kept away from flammable materials.
- Turn off gas supply at gas container after use.
- Do not alter this grill in any manner.
- Do not touch metal parts of grill until it has completely cooled (about 45 minutes) to avoid burns, unless you are wearing protective gear (BBQ mittens, pot holders, etc.).
- Note that parts sealed by manufacturer or its agent must not be altered.



- When assembling the grill, position the connection flexible tube so that it is protected against twisting.
- Stay away from any source of ignition when changing gas container.
- When assembling the grill, do not obstruct ventilation openings of grill's container compartment. We reserve the right to make minor technical adjustments to the device.
- When cooking with oil/grease, do not allow the oil/grease to exceed 350°F (177°C). Do not store or use extra cooking oil in the vicinity of this or any other appliance.
- Never fill the cylinder beyond 80% full. Not following the above information exactly may result in a fire causing death or serious injury.
- Do not store a spare LP gas cylinder under or near this appliance.

## **CAUTION**

- This grill is for use with propane gas only (propane gas cylinder not included).
- Never attempt to attach this grill to the self-contained propane system of a camper trailer, motor home or house.
- Do not use gasoline, kerosene or alcohol for lighting. The LP gas supply cylinder must be constructed and marked in accordance with the specifications for propane gas cylinders of the U.S. Department of Transportation (DOT) CFR 49.
- The gas supply cylinder must be provided with a listed overfilling prevention device.
- The gas supply cylinder must be provided with a cylinder connection device compatible with the connection for outdoor cooking appliances.
- This grill is not intended for use on recreation vehicles and/or boats.
- Do not use grill unless it is completely assembled and all parts are securely fastened and tightened.
- Keep all combustible items and surfaces at least 36 inches (91.4cm) away from grill at all times.
- DO NOT use this grill or any gas product near unprotected combustible constructions.
- Do not use in an explosive atmosphere. Keep grill area clear and free from combustible materials, gasoline and other flammable vapors and liquids.
- Never keep a filled container in a hot car or car trunk. Heat will cause gas pressure to increase, which may open relief valve and allow gas to escape.
- Keep grill's valve compartment, burners and circulating air passages clean. Inspect grill before each use.

## **WARNING**

- This grill is for outside use only, and should not be used in a building, garage, or any other enclosed area.
- The use of alcohol, prescription or non-prescription drugs may impair the operator's ability to properly assemble or safely operate the grill.
- Always open grill lid slowly and carefully as heat and steam trapped within the grill can burn you severely.
- Always place grill on a hard, level surface far away from combustibles. An asphalt or blacktop surface may not be acceptable for this purpose.
- Do not leave a lit grill unattended. Keep children and pets away from grill at all times.
- Do not place grill on any type of tabletop surface.
- Do not use grill in high winds.
- Disconnect the propane tank (LP tank) by first turning off valve on top of propane tank, turn off burner valves, then disconnect regulator from valve on propane tank by turning plastic connector counter clockwise. Unscrew wing-bolt in bottom shelf to release the tank for removal.

## **DANGER**

- Liquid propane (LP) gas is flammable and hazardous if handled improperly. Know its characteristics before using any propane product.
- Propane Characteristics: flammable, explosive under pressure, heavier than air and settles in pools and low areas.
- In its natural state, propane has no odor. For your safety, an odorant has been added.
- Contact with propane can cause freeze burns to skin.
- Never use a propane cylinder with a damaged body, valve, collar or footing.
- Dented or rusted propane cylinders may be hazardous and should be checked by your propane gas supplier.
- Use caution when assembling and operating your grill to avoid scrapes or cuts from sharp edges.
- Do not use gasoline, kerosene, or alcohol to light charcoal. Use of any of these or similar products could cause an explosion possibly leading to severe bodily injury.
- Use caution when moving grill to prevent strains.
- When adding charcoal and/or wood, use extreme caution.
- Never move grill when it is in use or when it contains hot coals or ashes.
- **WARNING:** To avoid injuries gloves or other protective articles should be used when touching the ash pan hangers.
- **Do not exceed a temperature of 650°F.**



- Do not allow charcoal and/ or wood to rest on the walls of grill. Doing so will greatly reduce the life of the grill.
- CAUTION: Exposed metal dampers on air vents and/or metal handles are hot during usage. Again, always wear oven mitts when adjusting air flow to protect hands from burns.
- When opening lid, make sure it is pushed all the way back so it rests against the lid support brackets. Use extreme caution as hood could fall back to a closed position and cause bodily injury.
- Close lid and all dampers to help suffocate flame.
- Always hold an open lid from the handle to prevent it from closing unexpectedly.
- Never leave coals and ashes unattended. Before grill can be left unattended, coals and ashes must be removed. Use caution to protect yourself and property.
- Ashes left in the grill (ash tray, grease tray, Flavor Drawer™, etc.) hold moisture and may cause rust if not cleaned out.
- Carefully place remaining coals and ashes in a noncombustible metal container and saturate completely with water. Allow coals and water to remain in metal container 24 hours prior to disposing.
- Make sure to empty grease tray after every use once completely cooled.
- Heat gauges maintain moisture, which will result in steam during cooking.
- Smoke will escape from other areas than smokestacks. This will not affect cooking.
- It is recommended that charcoal grill be heated up and fuel kept red hot for at least 30 minutes prior to first time cooking. Do not cook before briquettes have turned gray with ash.
- WARNING! Do not use spirit or petrol when lighting or relighting.
- To protect against bacteria that could cause illness, keep all meats refrigerated and thaw in refrigerator or microwave. Keep raw meats separate from other foods, and wash everything that comes in contact with raw meat.
- Cook meat thoroughly, and refrigerate leftovers immediately.
- Use a calibrated food thermometer and the USDA guidelines to ensure that meat, poultry, seafood, and other cooked foods reach a safe minimum internal temperature.
- Always have a fire extinguisher near at all times. Maintain and check your fire extinguisher regularly.
- Non-rechargeable batteries are not to be recharged.
- Do not mix different types of batteries such as alkaline, carbon-zinc, or rechargeable batteries.
- Do not mix old and new batteries.
- Exhausted batteries are to be removed from the product.
- Batteries included.
- **DO NOT DISPOSE OF BATTERIES IN FIRE. BATTERIES MAY EXPLODE OR LEAK.**

**\*\*\* STOP! CALL  FIRST! \*\*\***

**Do NOT Return Product to Store.**

This grill has been made according to the highest of quality standards. If you have any questions not addressed in this manual or if you need parts please call our Customer Service Department at 1-912-638-4724 (USA) or email Char-Griller at: [Service@CharGriller.com](mailto:Service@CharGriller.com) and have your serial number handy.

**REGISTER YOUR GRILL:**

To take full advantage of the Char-Griller warranty be sure to register your grill by visiting [www.CharGriller.com/Register](http://www.CharGriller.com/Register) or calling Customer Service at **1-912-638-4724**.

Registration provides important protections:

1. In the extremely unlikely event of a product recall Char-Griller can easily contact you and rectify the issue.
2. If a warrantied part is broken or missing we can send you the needed parts promptly.

*NOTE:* You will need your model #, serial number, and a copy of the original sales receipt when registering.

**Document Your Grill Model and Serial Numbers HERE:**

(Model and Serial number are located on the back of the grill body or on the leg.)

---

**(MODEL #)**

---

**(SERIAL #)**

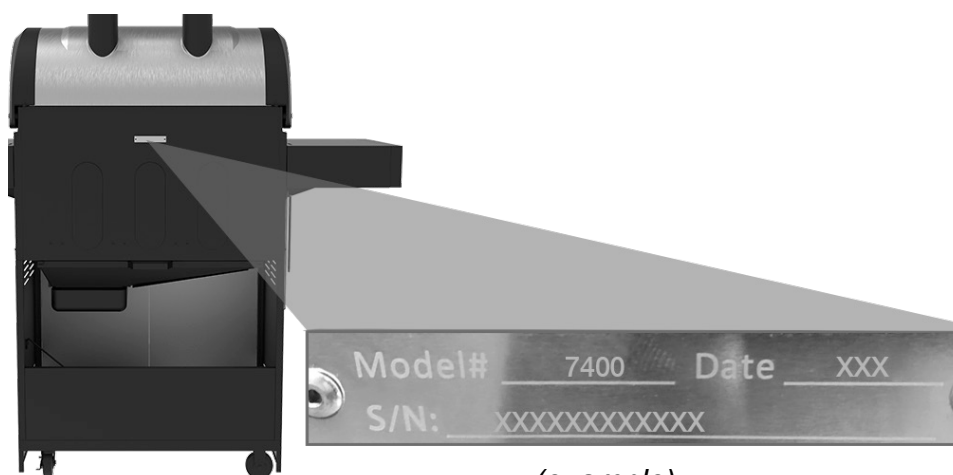





# WARRANTY INFORMATION

**A COPY OF THE DATED PROOF OF PURCHASE (RECEIPT) IS REQUIRED WHEN REGISTERING OR SUBMITTING A WARRANTY\* CLAIM. PLEASE RETAIN A COPY OF THE RECEIPT FOR YOUR RECORDS.**

Char-Griller will replace any defective part of its grillers/smokers, under warranty, as outlined below.

**PLEASE READ THIS INFORMATION IN DETAIL AND IF YOU HAVE ANY QUESTIONS CONTACT CUSTOMER SERVICE AT 912-638-4724 OR SERVICE@CHARGRILLER.COM.**

<b>Charcoal / Pellet / Kamado Grills</b>	
Grill - Hood AND Bottom (excludes removable Ash Pan)	5 years from date of purchase for rust through / burn through
Ash Pan AND Defective Parts	1 year from date of purchase
<b>Gas Grills</b>	
Grill Hood (TOP half) AND Main Burner Tubes (excludes Side Burner)	5 years from date of purchase for rust through / burn through
Grill Body (BOTTOM half) AND Side Burner AND Defective Parts	1 year from date of purchase
<b>Dual Fuel Grills (Gas &amp; Charcoal)</b>	
Charcoal Grill - Hood AND Bottom AND Gas Grill Hood (TOP half) AND Main Burner Tubes (excludes Ash Pan and Side Burner)	5 years from date of purchase for rust through / burn through
Ash Pan AND Defective Parts AND Gas Grill Body (BOTTOM half) AND Side Burner	1 year from date of purchase
<b>Parts, Accessories, and Grill Covers</b>	
	1 year from date of purchase (seam tears only for covers)

## **SURFACE RUST IS NOT CONSIDERED A MANUFACTURING OR MATERIALS DEFECT**

Char-Griller grills are made of steel and if exposed to the elements rust will occur naturally. Please refer to the section entitled, "Usage" to review how to care for your grill properly.

Surface issues such as scratches, dents, corrosion or discoloring by heat, abrasive and chemical clearers, surface rust or the discoloration of steel surfaces are NOT covered under these warranties.

Warranties are for the replacement of defective parts only. Char-Griller is not responsible for damage resulting from accident, alteration, misuse, abuse, hostile environments, improper installation, and installation not in accordance with local codes of service of unit.

### **Excluded Under ALL Warranties**

Paint; Surface Rust; Heat Damage; Incorrect Parts ordered by customer, including shipping; Worn Parts; Missing or damaged parts not reported within two (2) months of purchase date; Defective parts not reported within one (1) year of purchase date; Fading grill cover.

\*NOTE: For warranty claims, photos and prepaid return of the item in question may be required. Misuse, abuse or commercial use nullifies all warranties.



# PARTS LIST

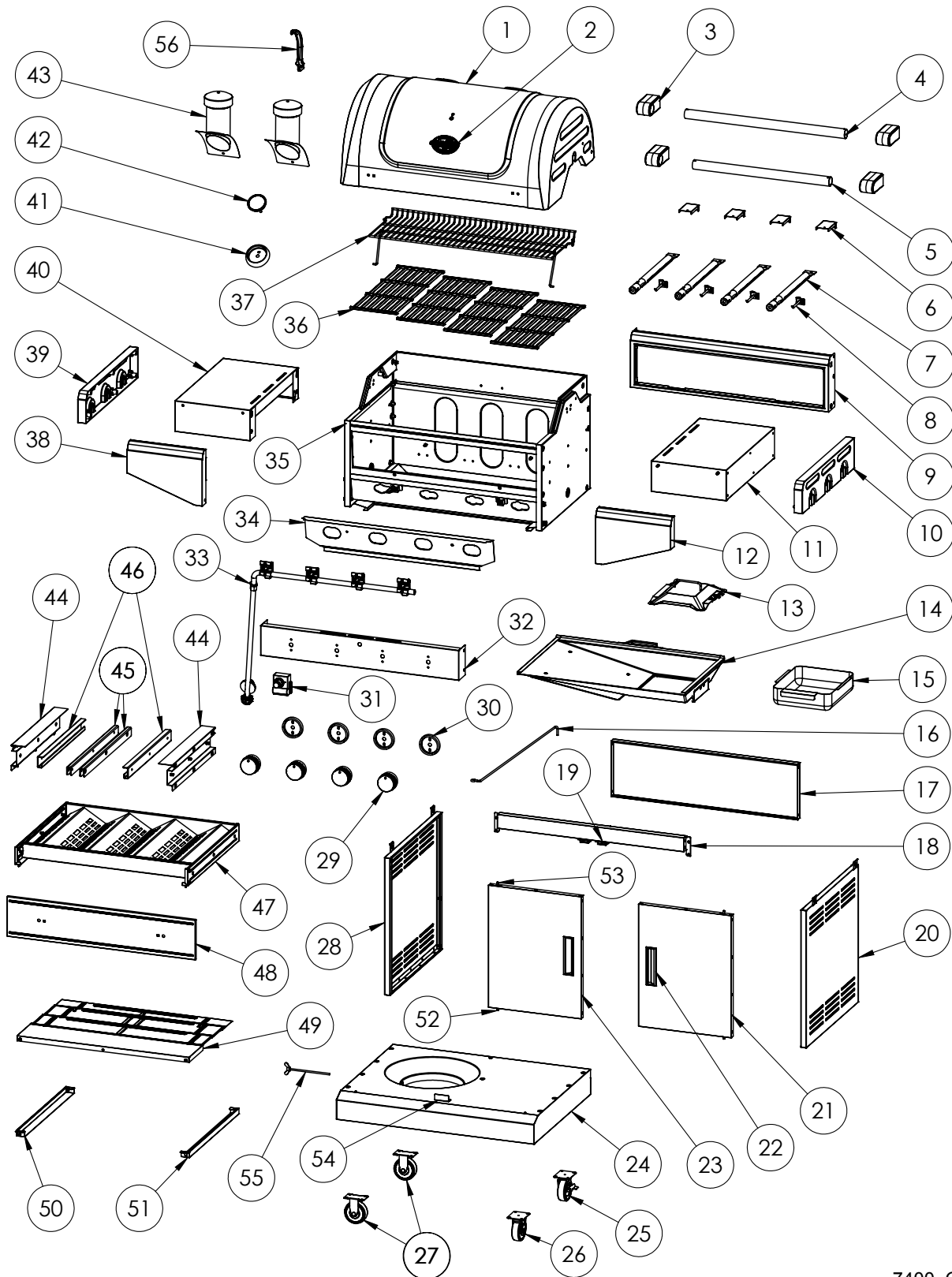

7400\_OM\_A.2



# PARTS LIST

Item	QTY	Part Name
1	1	HOOD
2	1	LOGO PLATE
3	4	HANDLE CAP
4	1	HOOD HANDLE
5	1	DRAWER HANDLE
6	4	BURNER SUPPORT BRACKET
7	4	BURNER
8	4	ELECTRODE WITH WIRE
9	1	DRAWER FASCIA
10	1	RIGHT SIDE SHELF CAP
11	1	RIGHT SIDE SHELF
12	1	RIGHT SHELF FASCIA
13	1	GREASE CUP LID
14	1	GREASE & ASH TRAY
15	1	GREASE CUP
16	1	TANK EXCLUSION WIRE
17	1	BACK PANEL
18	1	CART FRONT BRACE
19	2	DOOR MAGNET
20	1	CART RIGHT PANEL
21	1	RIGHT DOOR
22	2	DOOR HANDLE
23	1	LEFT DOOR
24	1	BOTTOM SHELF
25	1	LOCKABLE CASTER WHEEL
26	1	SWIVEL CASTER WHEEL
27	2	FIXED CASTER WHEEL
28	1	LEFT CART PANEL
29	4	KNOB
30	4	KNOB BEZEL

Item	QTY	Part Name
31	1	IGNITOR
32	1	CONTROL PANEL
33	1	HOSE/VALVES/REGULATOR ASSEMBLY
34	1	HEAT SHIELD
35	1	GRILL BODY
36	4	COOKING GRATE
37	1	WARMING RACK
38	1	LEFT SIDE SHELF FASCIA
39	1	LEFT SIDE SHELF CAP
40	1	LEFT SIDE SHELF
41	1	THERMOMETER BEZEL
42	1	THERMOMETER
43	2	ADJUSTABLE SMOKESTACK
44	2	SLIDER RAIL SUPPORT BRACKET
45	1	LEFT INNER SLIDER RAIL
46	1	RIGHT INNER SLIDER RAIL
47	1	DRAWER
48	1	DRAWER FRONT PLATE
49	1	EMBER TRAY
50	1	EMBER TRAY LEFT SUPPORT BRACKET
51	1	EMBER TRAY RIGHT SUPPORT BRACKET
52	2	DOOR SUPPORT PIN
53	2	UPPER DOOR SOCKET
54	1	DOOR BRACE
55	1	TANK HOLDER
56	1	GRATE LIFTER

7400\_OM\_A.2

**B-2**

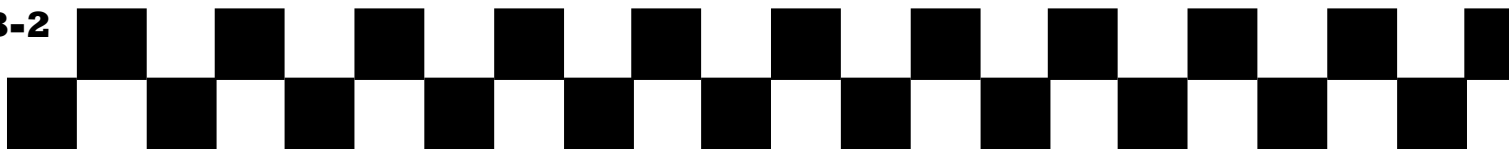

# HARDWARE AND TOOLS NEEDED

**Assembly:** Requires 2 people. Tools Needed: Pliers, Phillips Head Screwdriver and a 7/16" Nut Driver.

**NOTE:** Do Not tighten any bolts unless instructed to do so. Tightening too soon may prohibit parts from fitting together. All Hex Nuts should be on the inside of the grill unless stated otherwise. Unpack all contents in a well cleared and padded area.

**Estimated Assembly Time:** 45 minutes

## Hardware Pack:

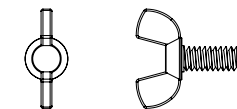
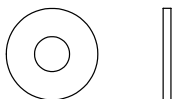
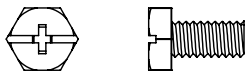

HEX BOLT, 1/4-20 X 1/2"	41
HEX BOLT, 1/4-20 X 1 3/4"	2
SCREW, #10-24	15
HEX NUT, 1/4-20	4
LOCK WASHER, 1/4"	28
FLAT WASHER, 1/4"	4
WING BOLT, 1/4-20 x 1/2"	4



# ASSEMBLY

## Step 1

Install Caster Wheels onto Bottom Shelf with four Lock Washers and four 1/2" Hex Bolts per Caster Wheel. Position the caster wheel as shown on the picture below.

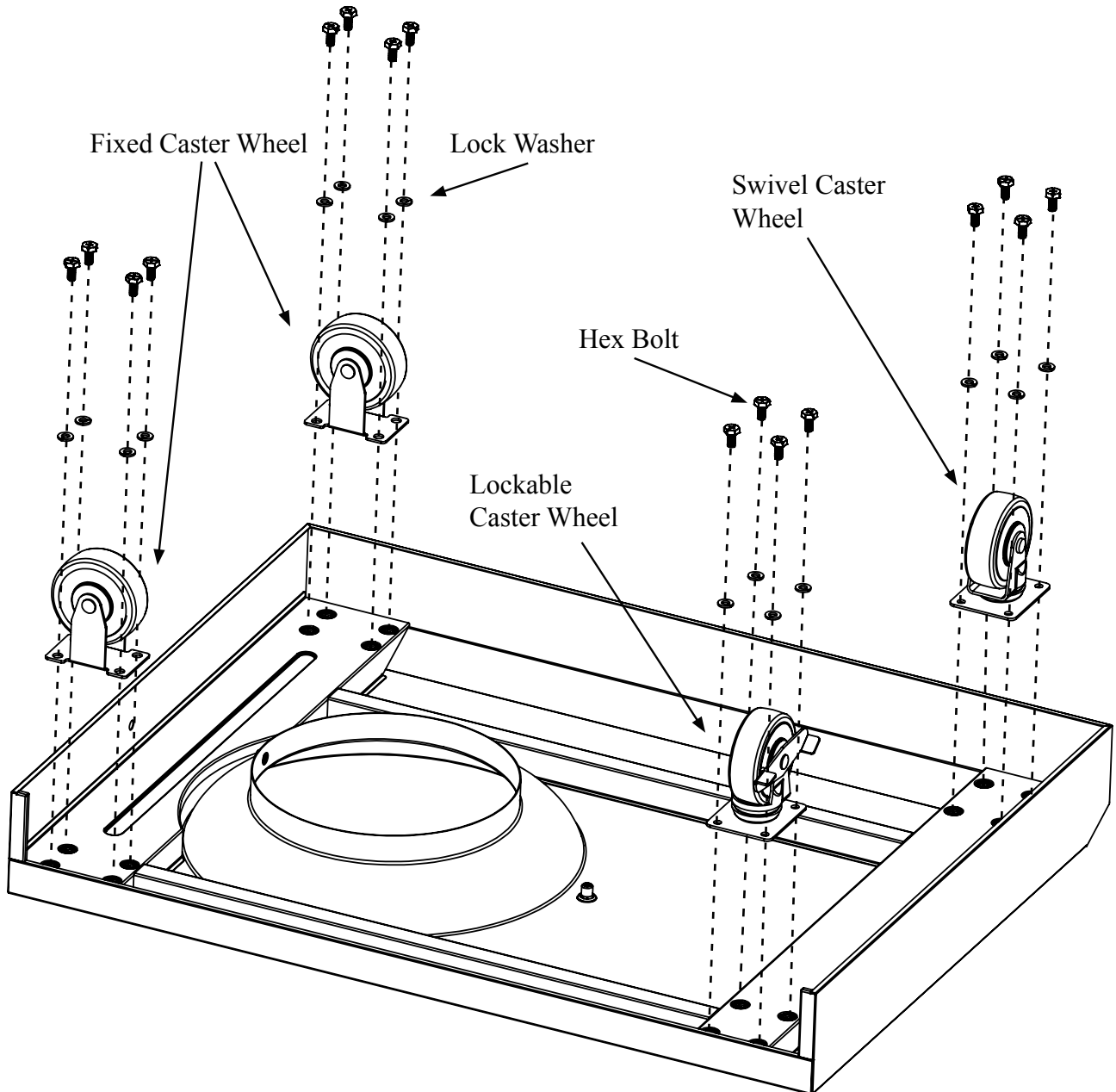

7400\_OM\_A.2

**B-4**

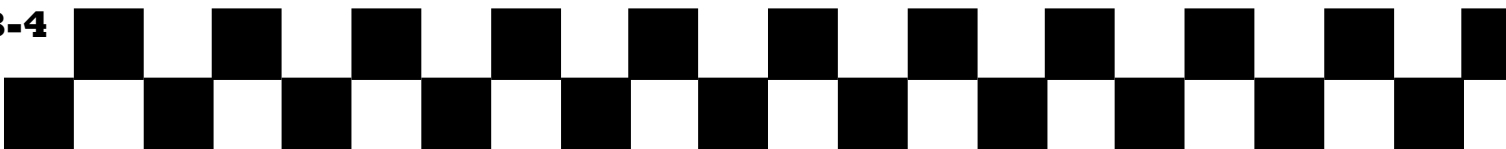

## Step 2

Install Left and Right Cart onto Bottom Shelf with four Lock Washers and four ½" Hex Bolts per side cart. Then install the Back Panel onto the Left and Right Cart with five #10-24 Screws.

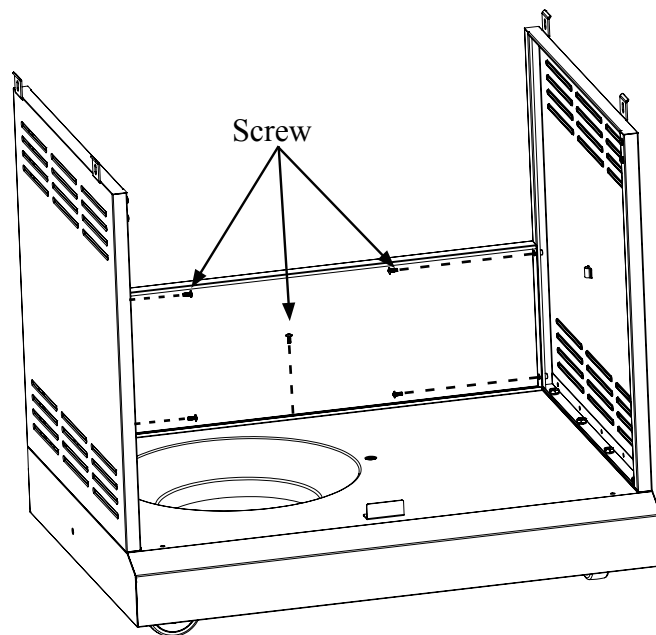
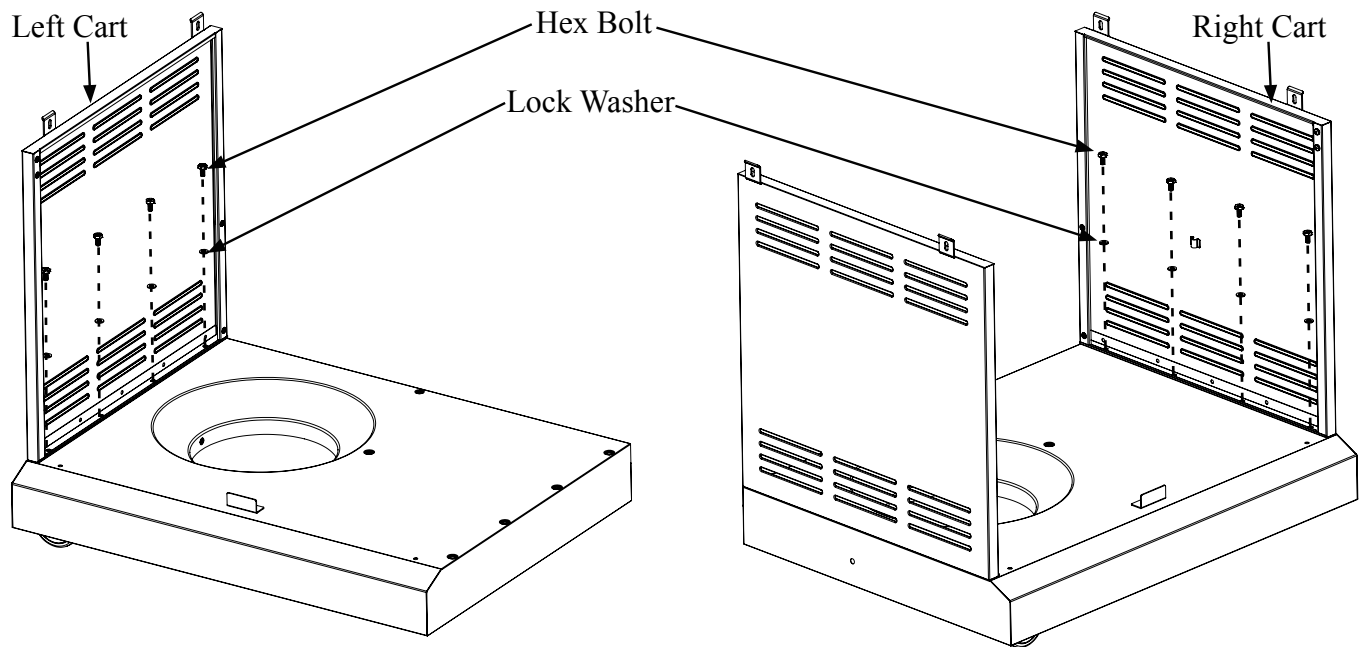



**Step 3**

Install Cart Front Brace onto the Left and Right Cart at the front with eight #10-24 Screws.

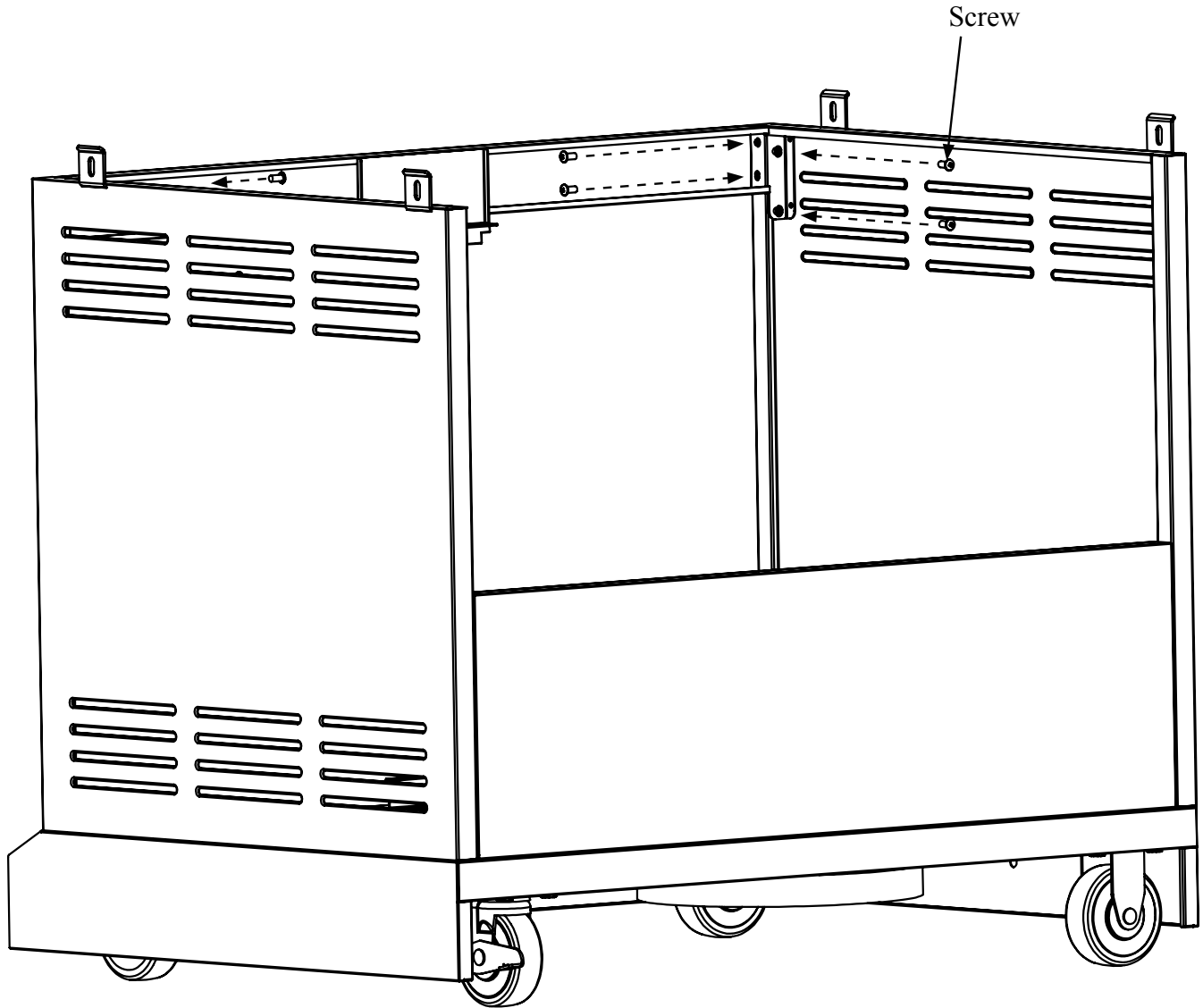

7400\_OM\_A.2

**B-6**

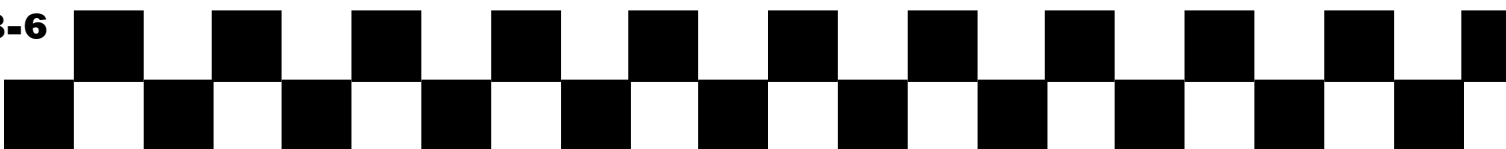

**Step 4**

Install the Tank Exclusion Wire inside of the cart with one 1/2" Hex Bolt.

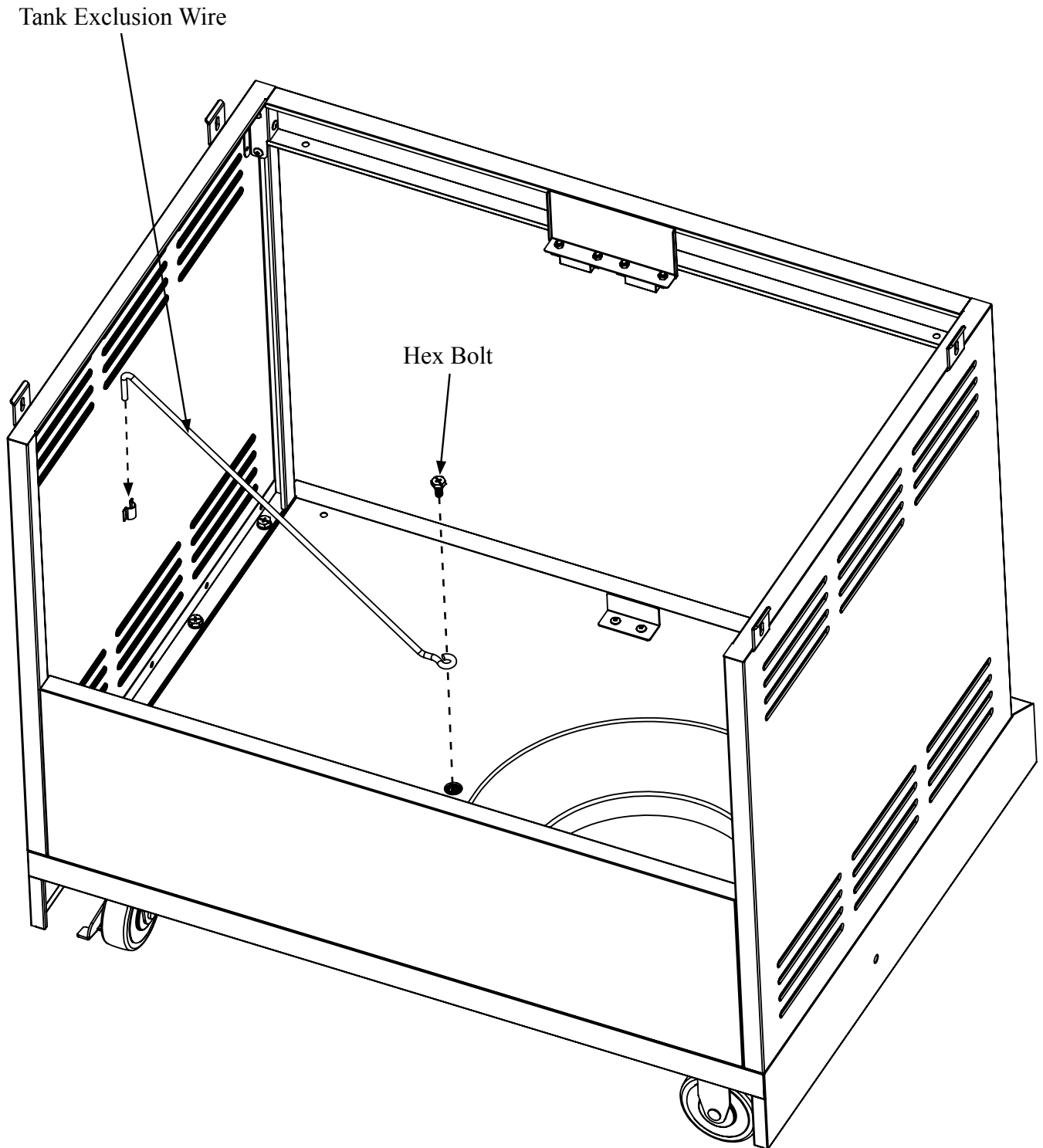





**Step 5**

Install Left Door with handle to Cart. Insert Door Support Pin at the bottom of the Front Door on the Bottom Shelf, then push in the Door Pin on top of the door and slide the door into position. Repeat process for right door.

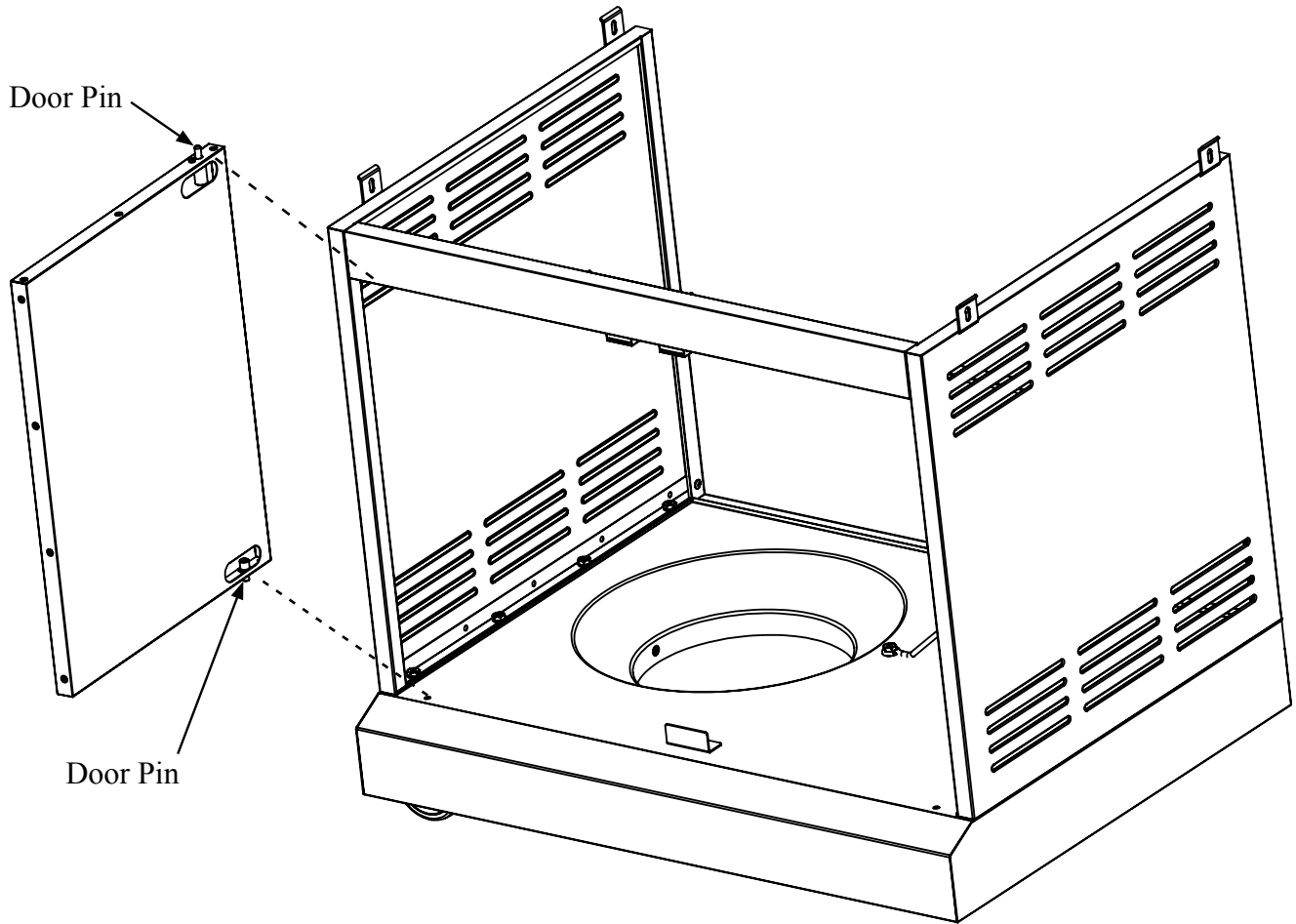

7400\_OM\_A.2

**B-8**

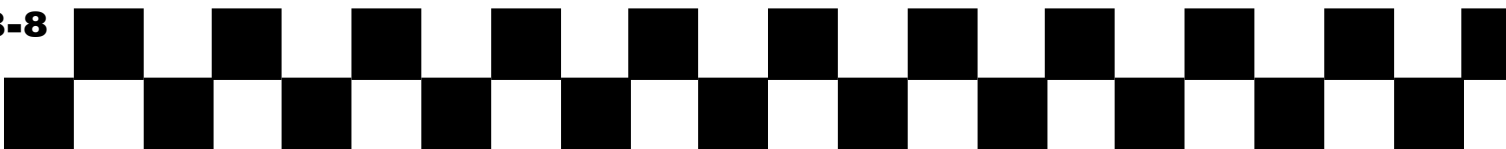

**Step 6**

Insert the Thermometer through the Thermometer Bezel then through the hole in Grill Hood (from outside) and secure with a Flat Washer and a Wing Bolt.

**NOTE: Thermometer hardware is included with Thermometer.**

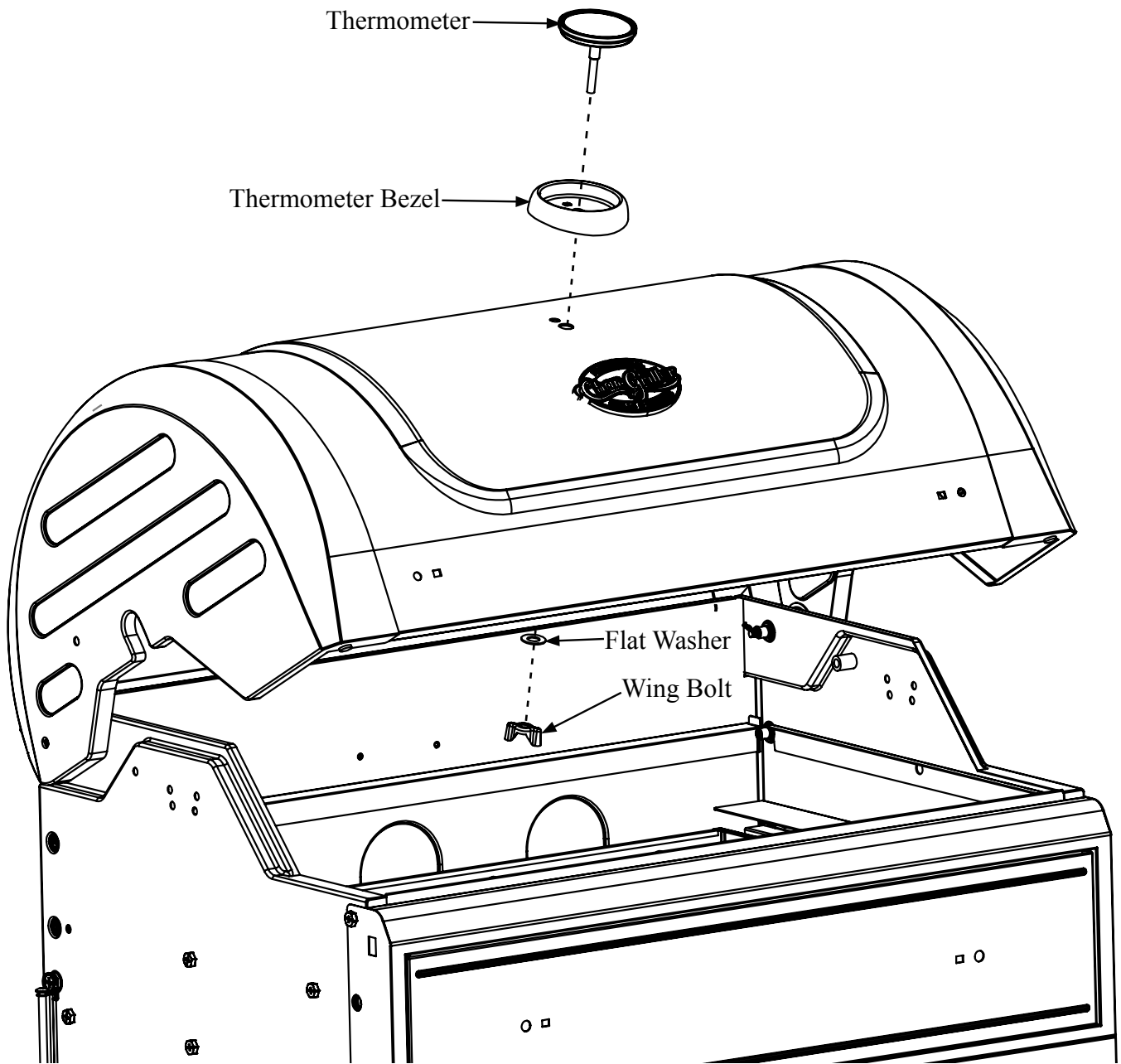



**Step 7**

Place Grill Body and Hood onto Cart and secure it with four 1/4-20 Hex Bolts.

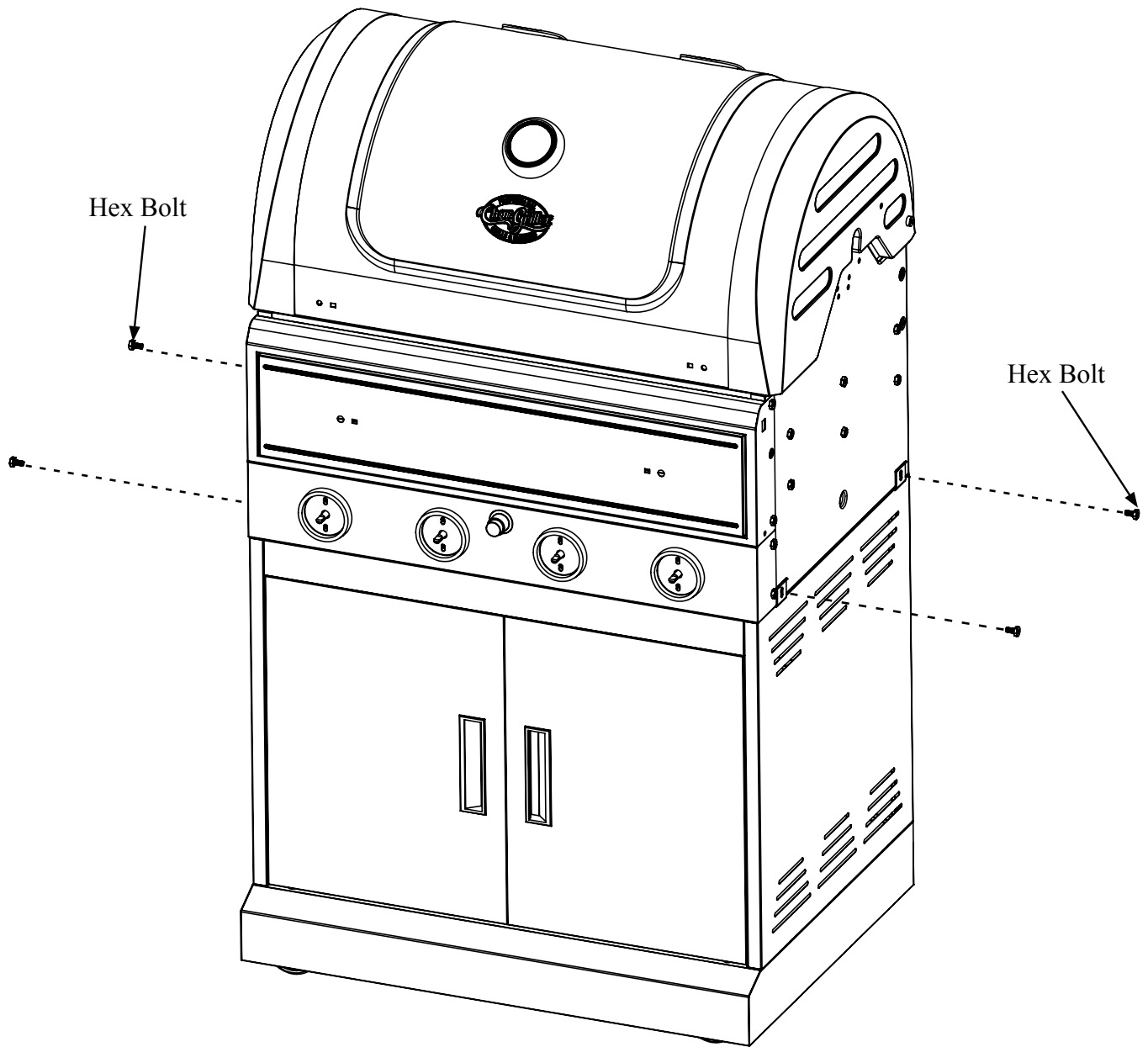

7400\_OM\_A.2

**B-10**

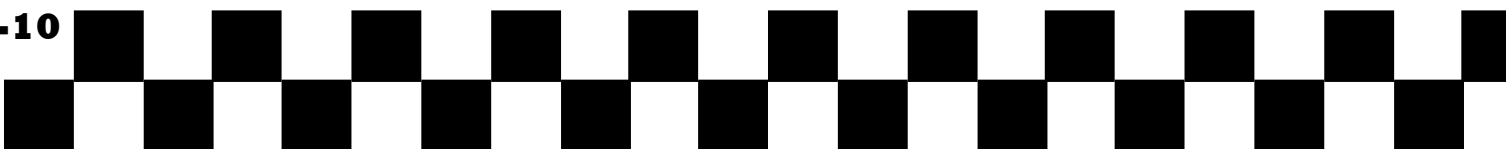

## Step 8

Install Left-Side Shelf Assembly to Grill Body.

First, loosen the top bolt on the Drawer Fascia; and loosely install three 1/2" Hex Bolts into side mounting holes on the Grill Body. Align keyhole on the Left-Side Shelf Assembly with the Hex Bolts on the Grill Body and push the Side Shelf down.

Secure the Side Shelf Fascia to the Side of the Drawer Fascia with one 1/2" Hex Bolt.

Then tighten all Hex Bolts. Repeat the same process for the Right-Side Shelf.

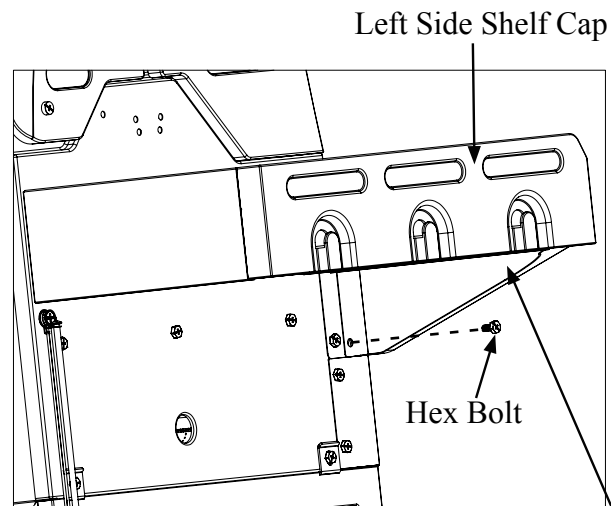
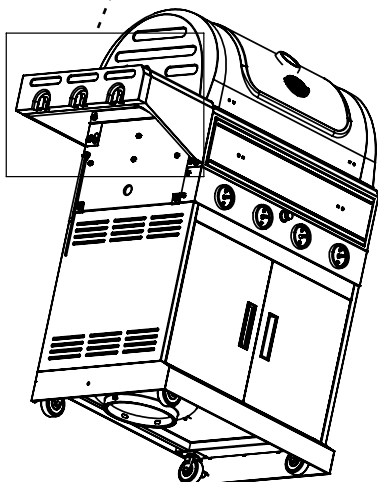
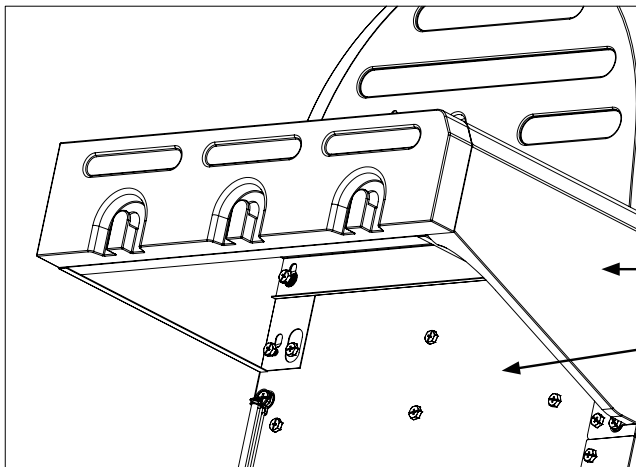
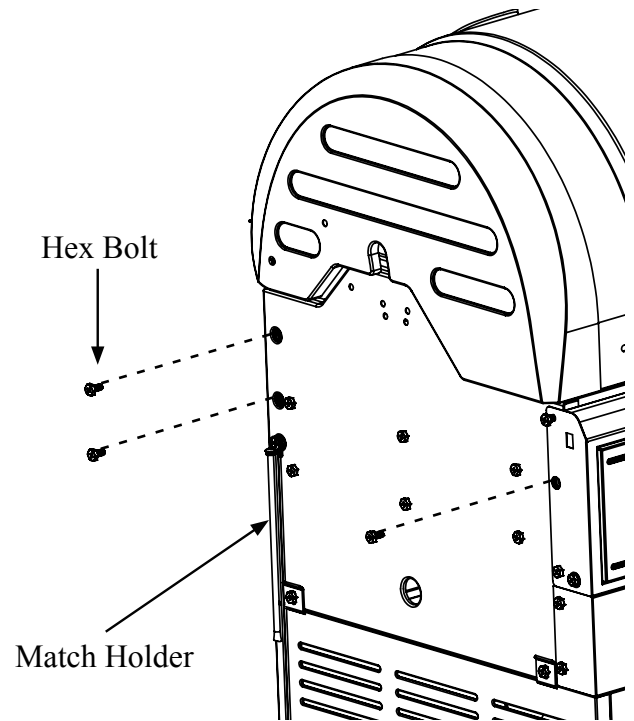

Left Side Shelf Fascia



**Step 9**

Open the Hood and install Hood Handle to Hood with two Flat Washers, two Lock Washers, and two Wing Bolts. Then install Drawer Handle to Drawer with two Flat Washers, two Lock Washers, and two Wing Bolts.

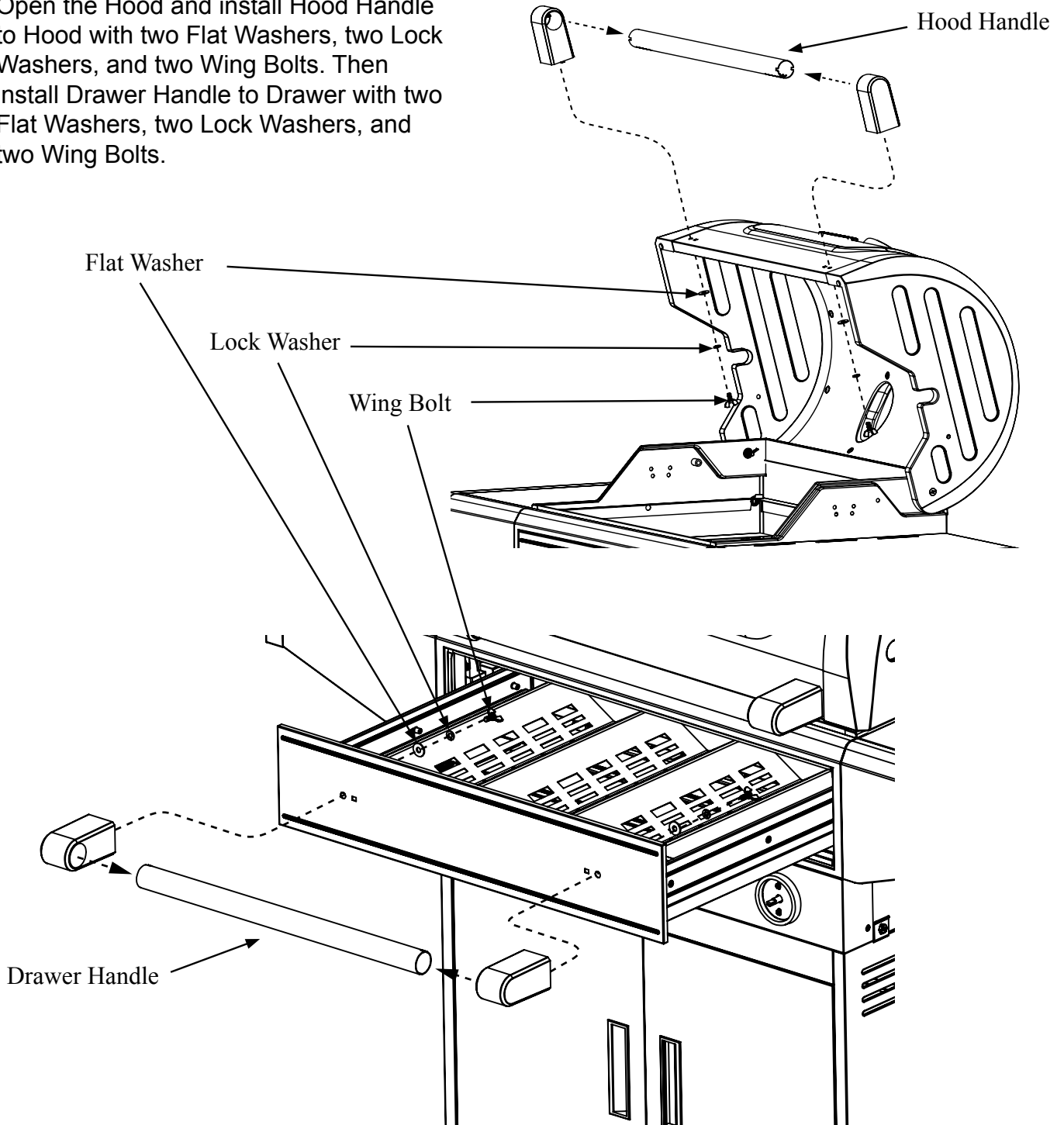

7400\_OM\_A.2

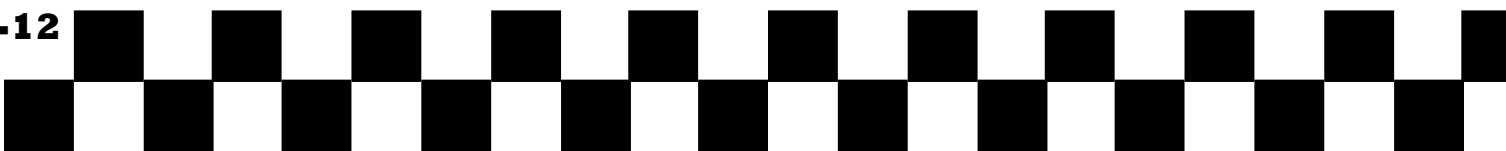

**Step 10**

Install Adjustable Smokestack on Grill Hood. Insert Smokestack Body through the hole on the Grill Hood and secure it with two Hex Bolts per Smokestack. Then screw on the Smokestack Cap to the Smokestack Body so that there is only 0.20" between the damper body and the damper cap as seen in the picture below.

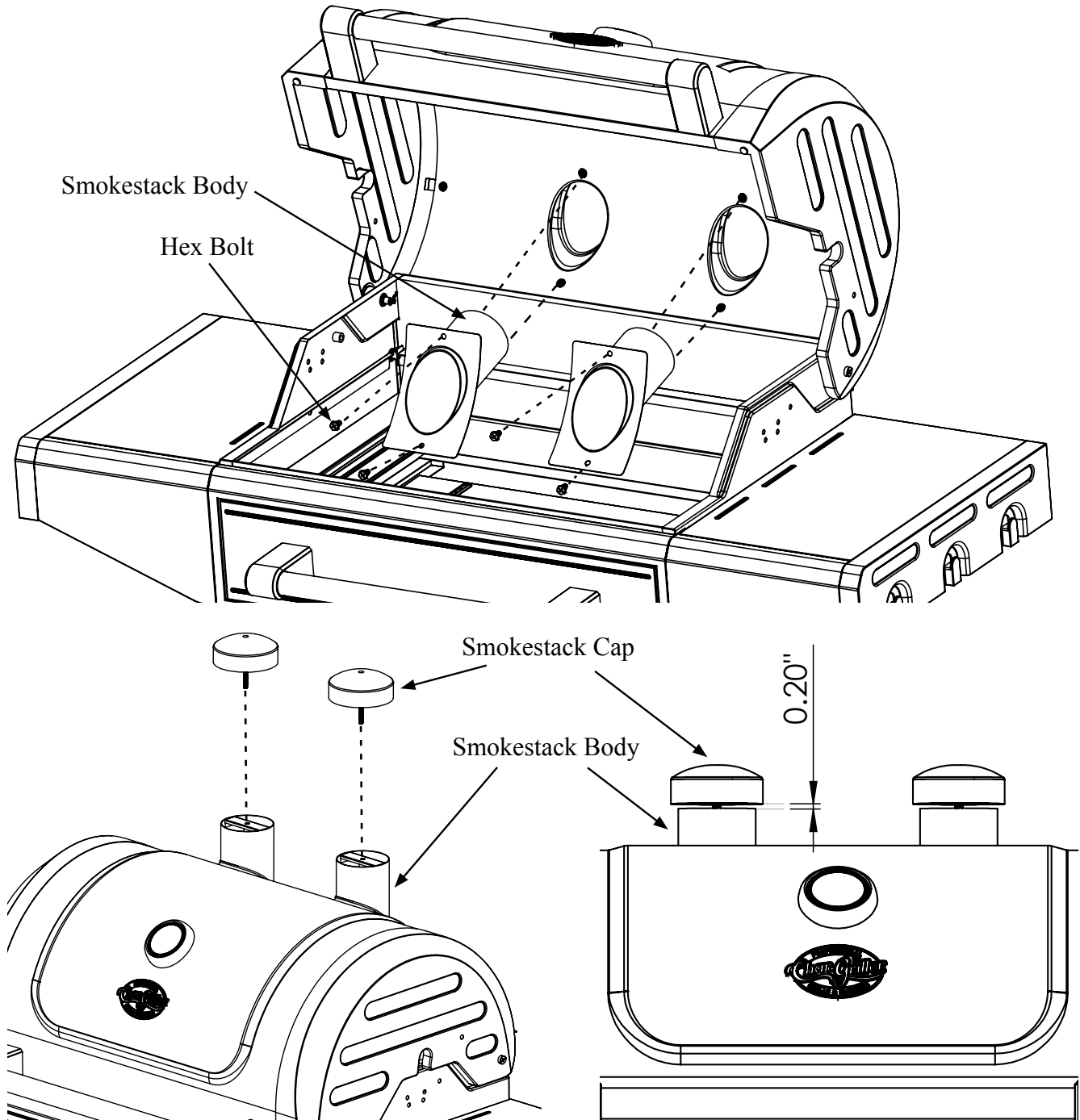



**Step 11**

**11A:** Install the Grease Cup Lid to the Grease & Ash Tray using two (2) #10-24 screws.

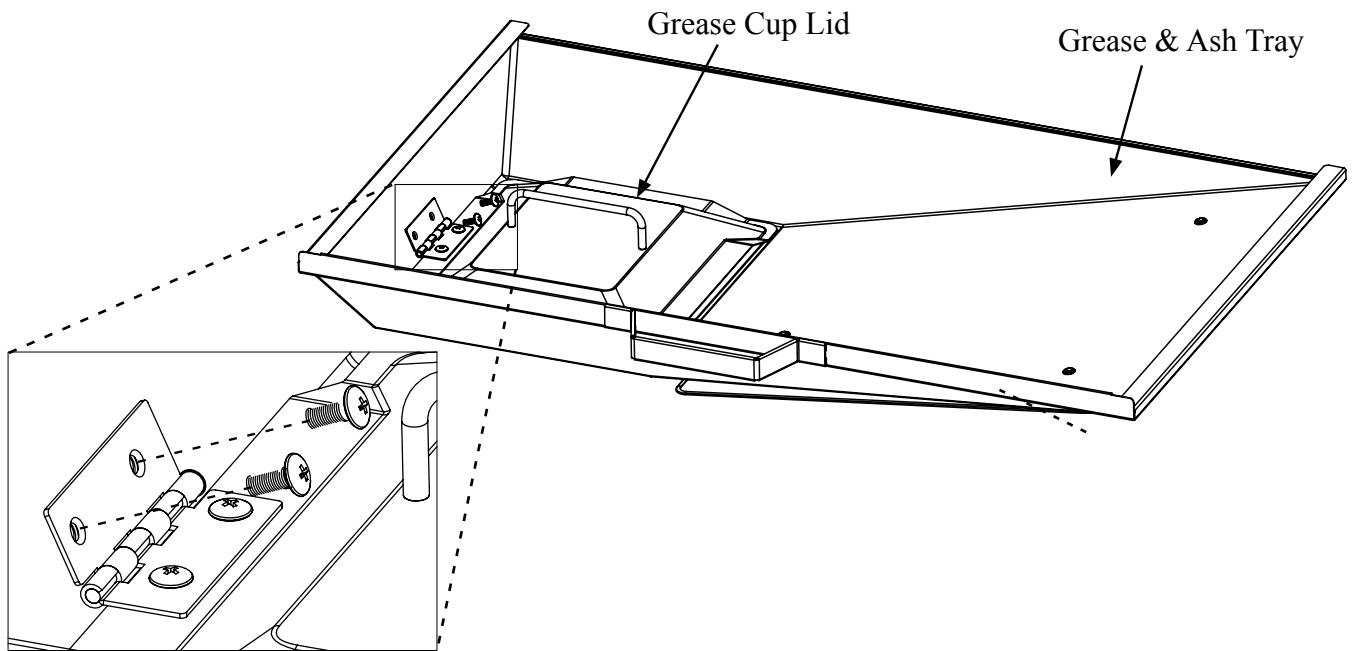

**11B:** Slide the Grease & Ash Tray on guide rail underneath the Grill Body from the back of the grill.

**11C:** Open Right-Side Front Door and slide the Grease Cup on guide rail underneath the Grease & Ash Tray.

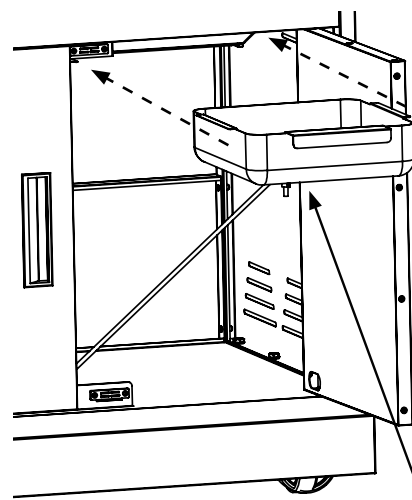
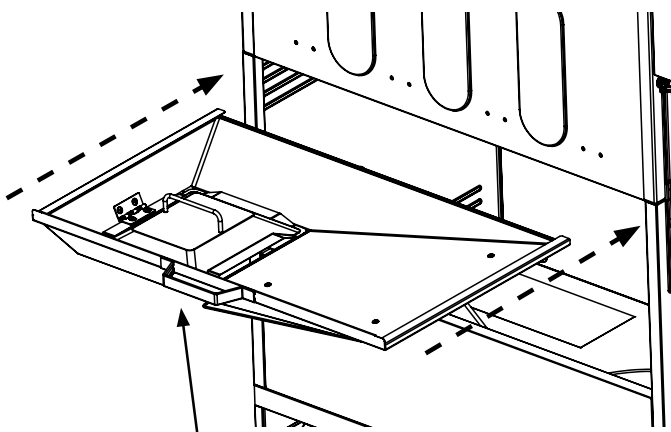

Grease & Ash Tray

Grease Cup

7400\_OM\_A.2

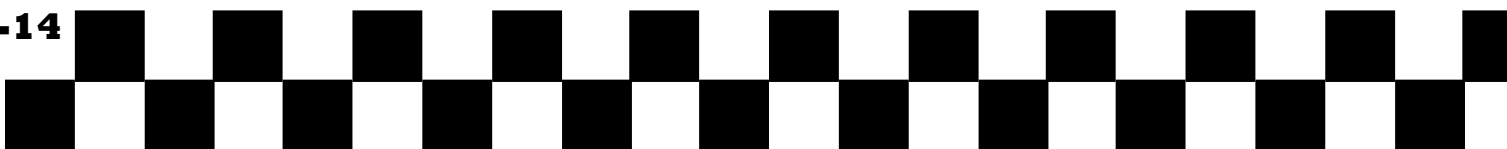

**Step 12**

Install the Knobs on the Control Panel.

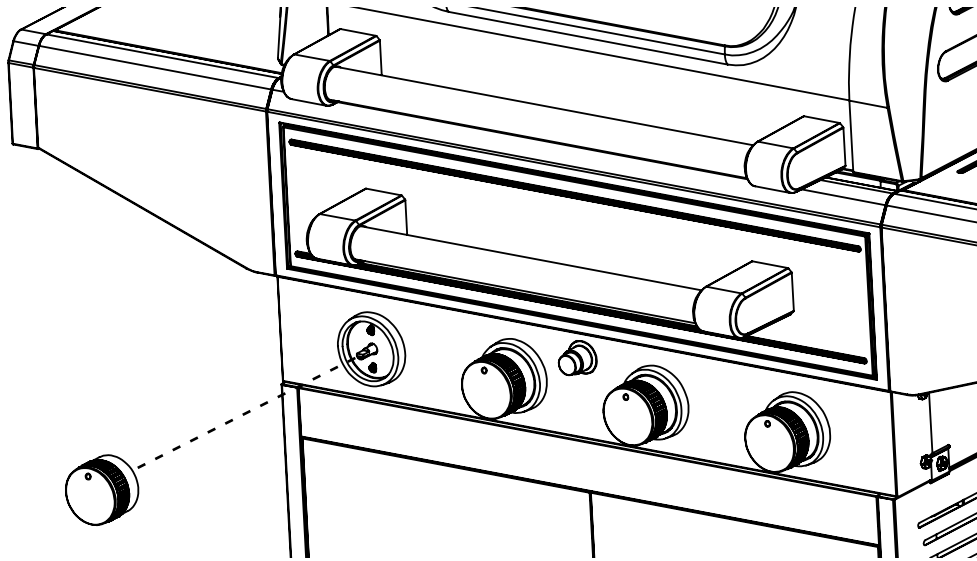





### Step 13

Place Cooking Grates inside Grill Body. Then Install Warming Rack onto Grill Hood and Body.

First attach two 1/4-20 x 1 3/4" Hex Bolts and two 1/4-20 Hex Nuts to Grill Hood. Align the loop on the Warming Rack onto the Hex Bolts.

Bend the Warming Rack Support Bracket inward slightly and slide the end of the Warming Rack Support Bracket into the Warming Rack Support on the Grill Body.

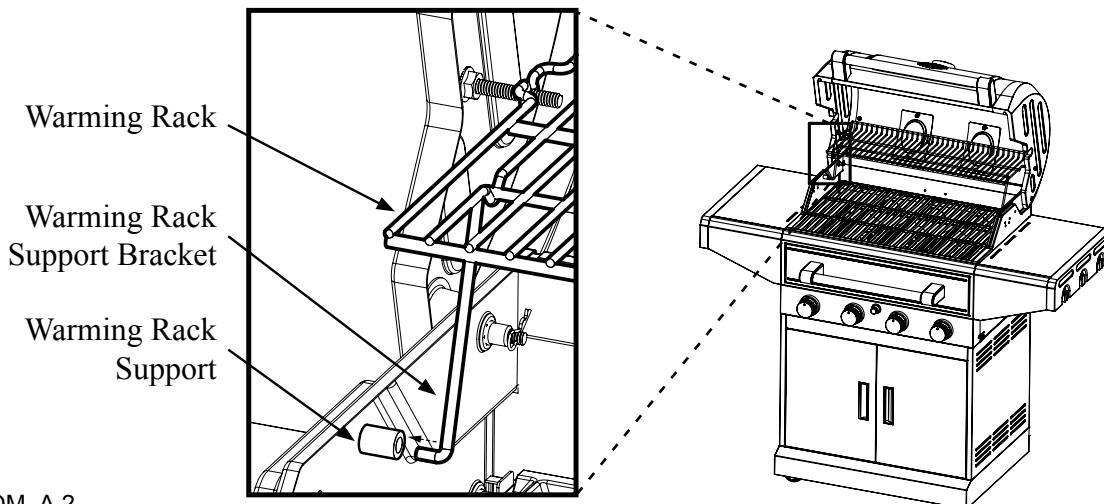
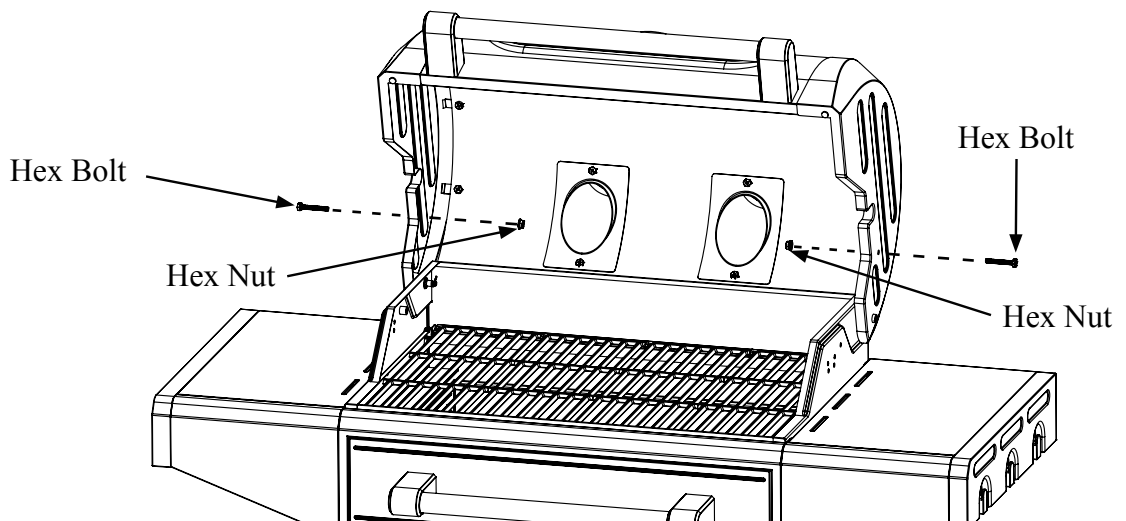
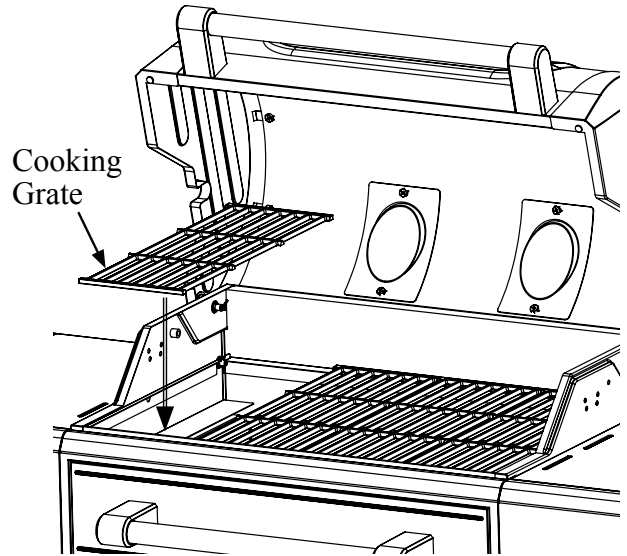

7400\_OM\_A.2

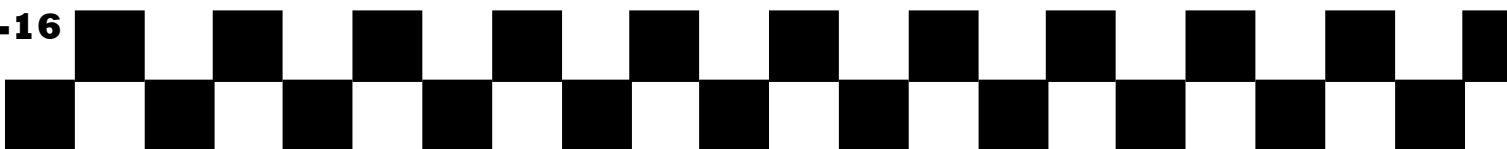

**Step 14**

Unscrew the Ignitor Cap and insert a “AA” Battery into the Ignitor Body then screw the Ignitor Cap back on. Screw on the Tank Bolt.

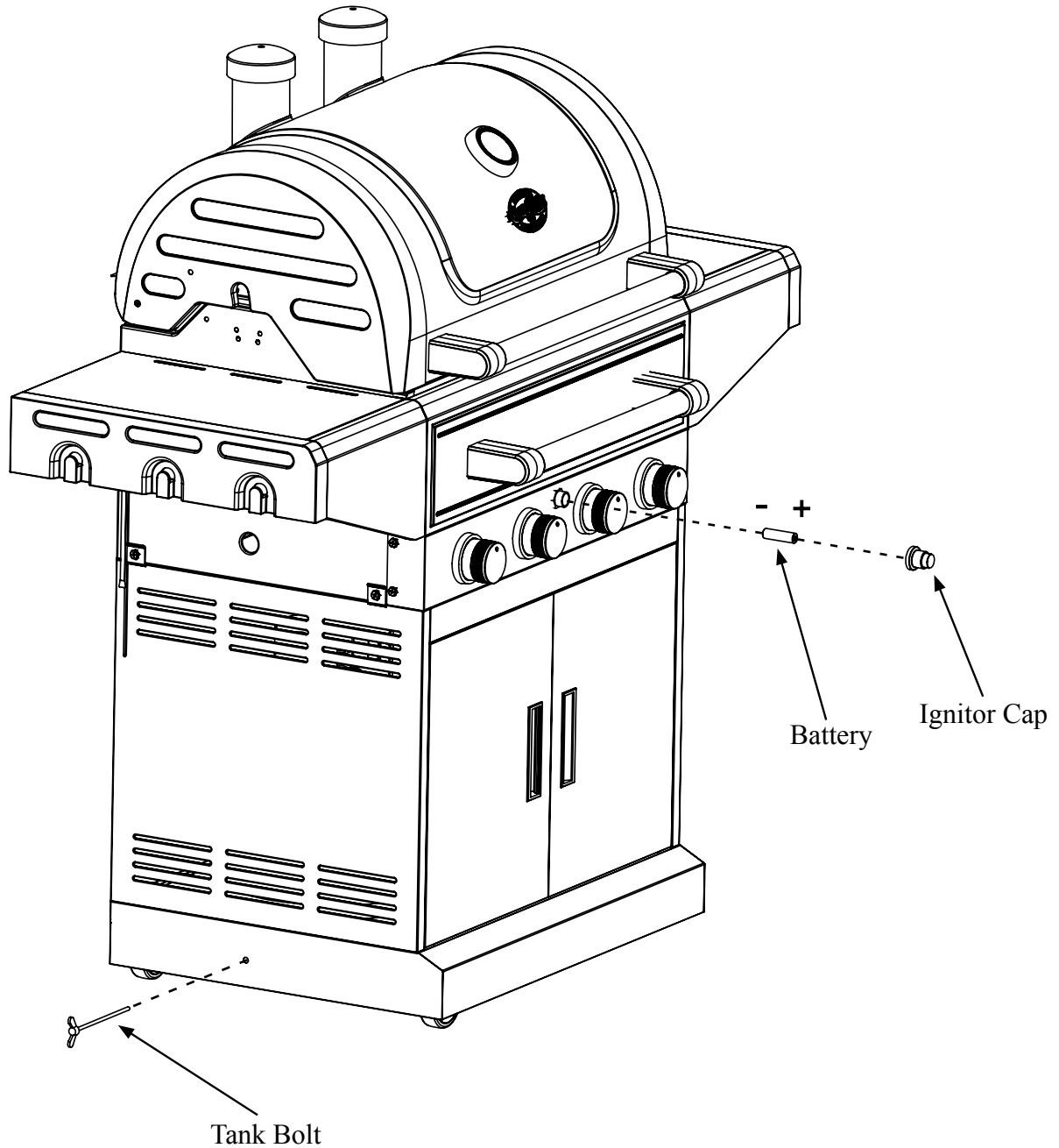

**Step 15**

Go back through Steps 1-13 and tighten all Bolts and Nuts.



## Fully Assembled



7400\_OM\_A.2

**B-18**

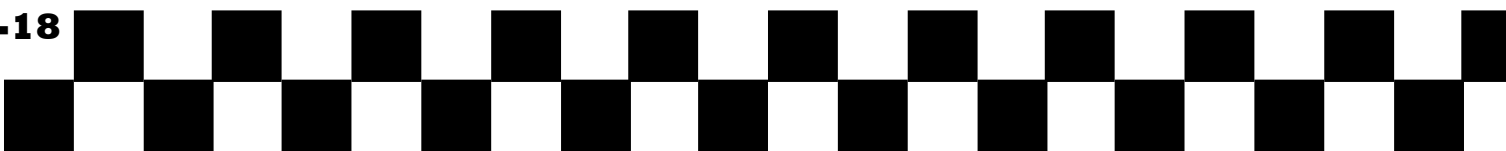

# OPERATING INSTRUCTIONS

## Cooking with the Flavor Pro™

The Flavor Pro™ can use both LP gas and charcoal as fuel sources and may be employed for either direct or indirect cooking. In order to save time, charcoal cooking may also be accelerated by utilizing the gas burners to shorten the time required to prepare coals. The Flavor Drawer™ may be used to enhance flavor with wood chips, chunks, logs and pellets. The following operating instructions will guide you through how to safely utilize these different functions on your Flavor Pro™ grill.

## Setting Up

This appliance is designed for use outdoors, away from any flammable materials. It is important that there are no overhead obstructions and that there is a minimum distance of 36 inches (90 cm) from the side or rear of the appliance. It is important that the ventilation openings of the appliance are not obstructed.

The grill must be used on a level, stable surface. The appliance should be protected from direct drafts and positioned or protected against direct penetration by any trickling water (e.g. rain). Do not move grill while hot, and do not leave unattended during operation.

Protect LP cylinder from direct sunlight and keep away from heat sources max. 122°F (50° C). Do not move grill while hot, and do not leave unattended during operation. Position gas cylinder such that hose is not bent, twisted, subject to tension, or touching any hot parts of appliance.

NEVER EXCEED 650°F BECAUSE THIS WILL DAMAGE THE FINISH AND  
CONTRIBUTE TO RUST. PAINT IS NOT WARRANTED AND WILL REQUIRE TOUCH-UP.  
THIS UNIT IS NOT WARRANTED AGAINST RUST.

## GAS OPERATION

### Regulator and Hose

These items are supplied with the appliance. If a replacement is necessary, please visit [chargriller.com](http://chargriller.com) or call our customer service department, 912-638-4724. Do NOT use replacement parts that are not intended for this grill. The life expectancy of the regulator is estimated as 10 years. It is recommended that the regulator is changed within 10 years of the date of manufacture.

The use of the wrong regulator or hose is unsafe; always check that you have the correct items before operating the appliance.

The hose used must conform to the relevant standard for the country of use. Worn or damaged hose must be replaced. Ensure that the hose is not obstructed, kinked, or in contact with any part of the grill other than at its connection.



## Connecting the Hose to the Appliance

Before connection, ensure that there is no debris caught in the head of the gas cylinder, regulator, burner, and burner ports. Spiders and insects can nest within and clog the burner/venturi tube at the orifice. A clogged burner can lead to a fire beneath the appliance.

Clean burner holes with a heavy-duty pipe cleaner.

If the hose is replaced it must be secured to the appliance and regulator connections with hose clips. Disconnect the regulator from the cylinder (according to the directions supplied with the regulator) when the appliance is not in use.

The appliance must be used in a well ventilated area. Do not obstruct the flow of combustion air to the burner when in use. **ONLY USE THIS APPLIANCE OUTDOORS.**

## Connecting the Gas Cylinder to the Grill

This appliance is only suitable for use with low-pressure butane or propane gas or LPG mixtures, fitted with the appropriate low-pressure regulator via a flexible hose. The hose should be secured to the regulator and the appliance with hose clips.

1. Ensure all control knobs are in the OFF position and verify that the gas cylinder valve is closed by turning the handle on the gas cylinder valve clockwise until it stops.
2. Remove the protective cap from the gas cylinder valve nozzle.
3. Hold the regulator in a straight line with the gas cylinder valve nozzle so the connection does not cross thread.
4. Insert regulator nipple into the gas cylinder valve nozzle opening.
5. Hand-tighten coupling nut in a clockwise direction. **Do not use tools!**
6. Perform a Leak Test. (See Leak Testing section of this manual).

### **\*\* BEFORE USE CHECK FOR LEAKS \*\***

*Never check for leaks with a naked eye. Always use a soapy water solution.*

**NOTE:** Before starting the grill, check for leaks. Make sure the regulator valve is securely fastened to the burner and the cylinder to prevent fire or explosion hazard when testing for a leak.

Always perform the "Leak Test" as described below before lighting the grill or each time the cylinder is connected for use.

- Do not smoke or allow other sources of ignition in the area while conducting a leak test.
- Conduct leak test outdoors in a well-ventilated area.
- Do not use matches, lighters or a flame to check for leaks.
- Do not use grill until any and all leaks are corrected. If you are unable to stop a leak, disconnect the propane supply. Call a gas appliance serviceman or your local propane gas supplier.

## Leak Test

1. In a spray bottle mix 6-9ml. solution, 1 part dish washing soap, 3 parts water.
2. Ensure control valves/burner knobs are in the off position and that regulator is securely connected.
3. Open LP cylinder valve completely by turning wheel counterclockwise.
4. Apply the solution to the hose, gas valve, and regulator, and cylinder.
5. If bubbles form and grow on any of the tested components, there is a leak in the component. No bubbles means no leak.
6. If a leak has been identified please retest starting with steps 2-5. If leak persists, call customer service, 912-638-4724 or consult your owner's manual for how to replace or repair grill components.

## Lighting Instructions

Always open hood while igniting grill. If grill does not light, always wait 5 minutes for gas to clear before relighting. Failure to do either may result in an explosive flare-up, which can cause serious bodily injury or death. Once lit, but before cooking on grill for first time, let grill sit for 15 minutes with hood closed. This heat cleans grill's internal parts from anything they may have come into contact with during manufacturing and shipping.

## Main Burners

Make sure there are no obstructions of airflow to gas unit. Spiders and insects can nest within and clog the burner tube. A clogged burner tube can lead to a fire beneath appliance.

1. Make sure all burner knobs are in OFF position and the grill hood is open.
2. Open valve on LP gas cylinder.
3. To ignite a burner, push in and rotate knob counterclockwise to "HI," then push and hold Electronic Ignition Button until burner lights. If burner does not light in 5 seconds, turn burner OFF, wait 5 minutes for gas to clear and repeat procedure.  
Repeat for all desired burners. Light only burners intended for use.
4. Adjust knobs to desired cooking setting.

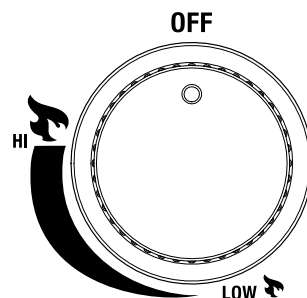

**After lighting**, observe burner flame and make sure all burner ports are lit.

**If burner flame goes out during operation**, immediately turn gas off on control panel and gas cylinder valve. Open hood and let gas clear for 5 minutes before relighting. **Clean grill after each use.** DO NOT use abrasive or flammable cleaners, as they damage parts and may start a fire.

## Shutting Off Burners

1. Turn knob(s) clockwise to HI position, then push in and turn to OFF. Never force knob without pushing in, as this can damage valve and knob.
2. Promptly close gas cylinder valve.
3. Close grill hood.



## Lighting Burner with a Match

1. Open grill hood.
2. Push in and rotate knob counterclockwise to HI position.
3. Place match in match holder installed on the side of the grill housing. Once lit, place flame through cooking grates near burner ports, as shown. Burner should light immediately.
4. Adjust knobs to desired cooking settings.

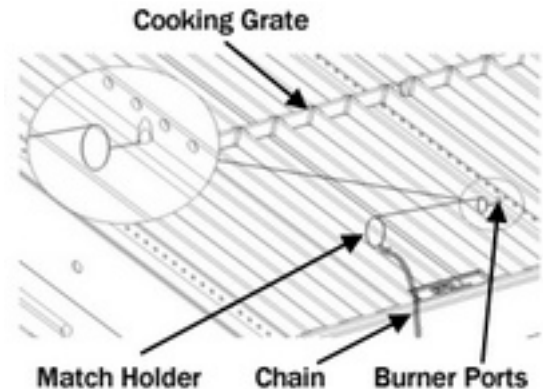

## Observe Flame Height When Lit

Open Flavor Drawer™ so that you can see burner flames below. Flame should be blue and yellow in color and approximately 1/2 in. - 3/4 in. (1.2 cm - 1.9 cm) tall on HI setting.

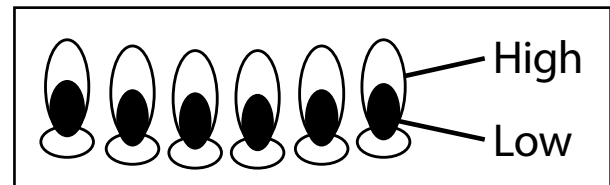

## Disconnecting the Gas Cylinder

1. Turn all control knobs to the OFF position and turn the handle on the gas cylinder clockwise until it stops.
2. Turn coupling nut on regulator in a counter-clockwise direction until regulator is released from threaded gas cylinder valve nozzle.
3. Place the protective cap over gas cylinder gas nozzle.

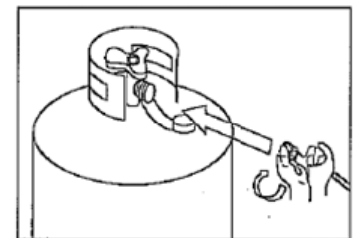

## Storage of Appliance

Storage of an appliance indoors is only permissible if the cylinder is disconnected and removed from the appliance. When the appliance is not in use, it should be covered and stored in a dry, dust-free environment. To maximize life of the grill, use a custom-fit Char-Griller Cover (Model #7455).

## Gas Cylinder

The gas cylinder should not be dropped or handled roughly! If the appliance is not in use, the cylinder must be disconnected. Replace the protective cap on the cylinder after disconnecting the cylinder from the appliance.



Cylinders must be stored outdoors in an upright position and out of the reach of children. The cylinder must never be stored where temperatures can reach over 122°F (50° C). Do not store the cylinder near flames, pilot lights or other sources of ignition. **DO NOT SMOKE NEAR A GAS CYLINDER.**

Again, this appliance is designed for use outdoors, away from any flammable materials. It is important that there are no overhead obstructions and that there is a minimum distance of 36 inches (90 cm) from the side or rear of the appliance. It is important that the ventilation openings of the appliance are not obstructed. The grill must be used on a level, stable surface. The appliance should be protected from direct drafts and positioned or protected against direct penetration by any trickling water (e.g. rain).

**Parts sealed by the manufacturer or its agent must not be altered by the user. No modifications should be made to any part of this appliance and repairs and maintenance should only be carried out by a registered service engineer or technician.**





# FLAVOR DRAWER™ OPERATING INSTRUCTIONS

## CHARCOAL OPERATION

### Gas-Assisted Charcoal Lighting Instructions

1. To start a gas-assisted charcoal fire, place up to 3 lbs. (approx. 50-60 briquettes) of charcoal in the Flavor Drawer™, divided equally between each of the Wood Product Zones. Only place charcoal in the three Wood Product Zones (Identified below). Do not place briquettes in the space on the far edges of the drawer.

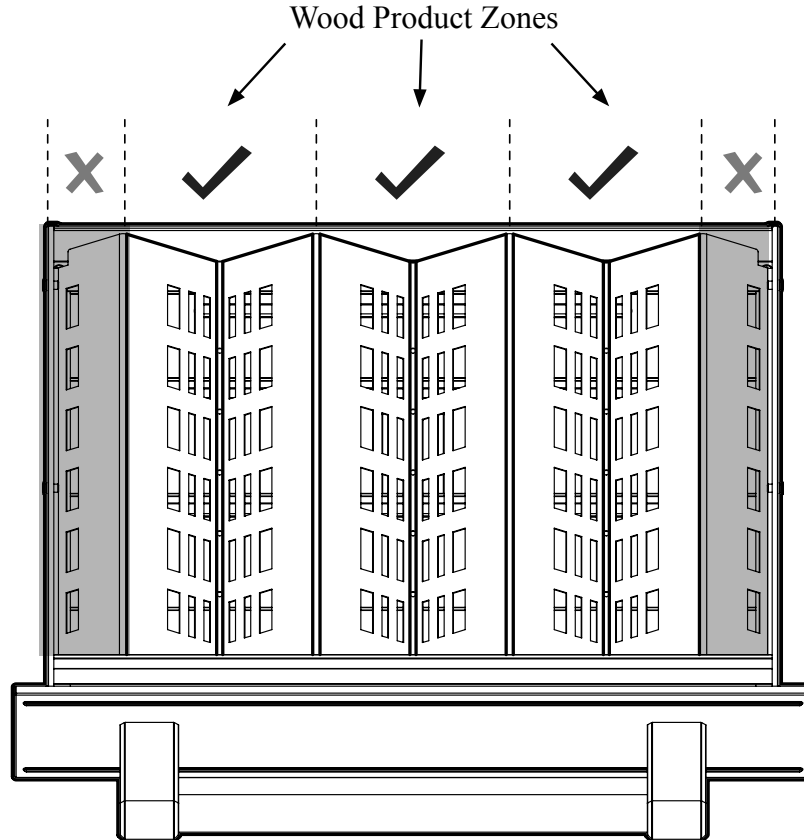

2. Using the Gas Operation instructions, follow the steps for lighting the Main Burners on HI.
3. After the briquettes are glowing red (typically after 5-6 minutes), turn the Main Burners to OFF.
4. Once the briquettes ash over or turn gray, spread them out, close the drawer and begin cooking.
5. If necessary, use tongs to move coals for even heat.

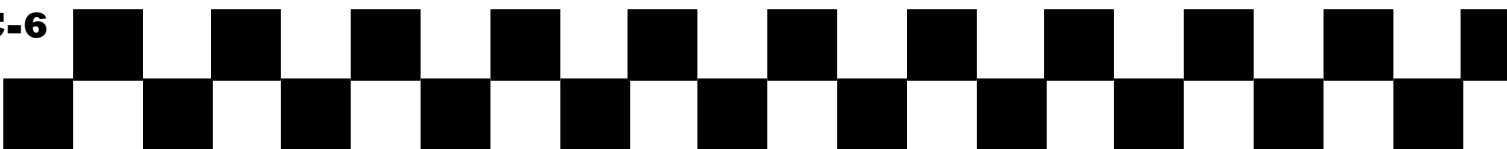

## Traditional Charcoal Lighting Instructions

1. To start a charcoal fire, place up to 3 lbs. (approx. 50-60 briquettes) of charcoal in the Flavor Drawer™, divided equally between each of the 3 Wood Product Zones. Do not place briquettes in the space on the far edges of the drawer (see illustration on page C-5).
2. Place a fire starter in each Wood Product Zone.

**NOTE: Do not use gasoline, kerosene or alcohol for lighting charcoal. Use of any of these or similar products could cause an explosion possibly leading to severe bodily injury.**

3. Close Flavor Drawer™, open the grill hood and light fire starter in each Wood Product Zone with extended reach lighter.
4. Once the briquettes ash over or turn gray, open drawer and spread them out. If necessary, use tongs to move coals for even heat.
5. Close the drawer and begin cooking.

## Finishing Up

When you are finished charcoal grilling, make sure all gas burner knobs and the gas cylinder are turned off and close the hood. Wait until coals and ash have completely cooled before attempting to clean up or remove. Be patient. This may take an hour or more.

## Emptying the Ashes and Grease & Ash Pan:

**\*\* ONLY EMPTY ASHES ONCE GRILL IS NOT IN USE AND COOL TO THE TOUCH \*\***  
**\*\* DO NOT EMPTY ASHES DURING GRILL USE OR WHEN GRILL IS HOT \*\***

Wait until after the fire is completely extinguished and the grill is cool to the touch before emptying the ashes to ensure they are not still hot and a burn hazard.

1. Knock any ashes that did not fall into the Grease & Ash Pan from the Flavor Valleys by opening and closing the Flavor Drawer™ several times.
2. Tap the sides of the Grease & Ash Pan to knock loose any ash.
3. Remove the Grease & Ash Cup from the bottom of the Grease & Ash Tray.
4. Dump the ashes from the Grease & Ash Cup in a metal container and cover with water to ensure there are no lit coals.
5. Remove the Grease & Ash Tray and set the Grease & Ash Cover to the side.
6. Dump the ashes from the Grease & Ash Tray in a metal container and cover with water to ensure there are no lit coals.
7. Reinstall the Grease & Ash Tray, Cover and Cup on the grill.

**IMPORTANT: Charcoal absorbs and retains moisture when not in use. DO NOT leave charcoal in your grill while you are not using it. Charcoal and ashes left inside the ash pan may reduce the life of your grill.**



## Cooking with Gas/Charcoal/Wood

Your Flavor Pro™ grill allows you to cook with both gas and charcoal and may be used to smoke, char-grill or sear your food. By using temperature zones, charcoal, gas burners and wood flavor, you can customize your culinary experience as desired. The following descriptions provide 3 of the most common ways you can cook with your Flavor Pro™ grill.

WOOD TYPE	QUANTITY	GAS TEMPERATURE
Chips	5 ounces	Low
Chunks	16 ounces	Low - Med/Low
Logs	3 in. diameter log	Low - Med/Low
Pellets	8 ounces	Low

### Char-Grill

Cook with direct and indirect heat at medium temperatures (300°-450°F). Use cool zone to slow cook temperatures. Best practice is to initially cook each side of food over direct heat and then move to cool zone until food reaches desired internal temperature.

1. Prepare up to 2 lbs (approximately 30-40 briquettes) of charcoal spread evenly between the 2 right most Wood Product Zones.
2. Using the Flavor Drawer™ Operation instructions, follow the steps for lighting the charcoal and bring to temperature. You may also use the gas burners as necessary to assist in controlling the desired temperature.
3. Once the grill is to desired temperature, you may begin to cook. Initially place food on right side of grill over direct heat, cooking each side as desired. After initial cook over direct heat, move to the left side Cool Zone (see picture at right) to bring your food to the desired internal temperature.
4. NOTE: Water soaked wood chips, chunks or logs may be used in addition to charcoal to add smoke flavor as desired.

### CHAR-GRILL (Direct Heat) - 300°-450°F Up to 2 lbs. Charcoal (30-40 Briquettes)

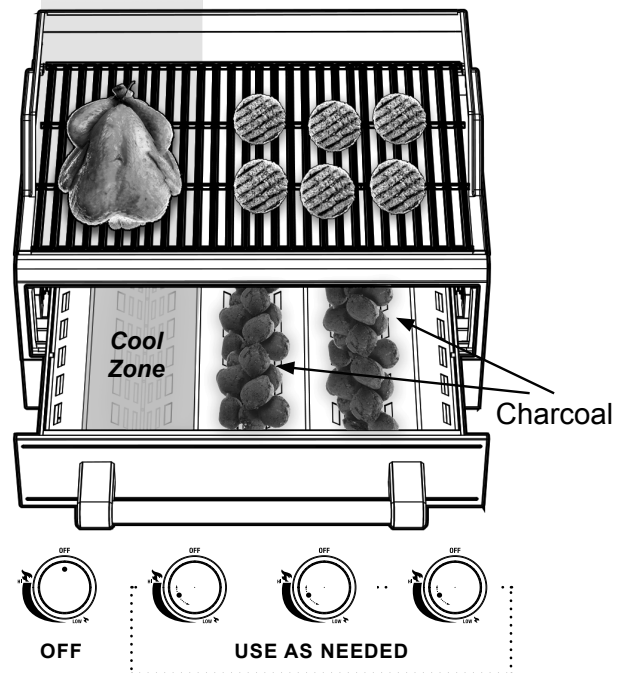

## Sear

Quickly cook with direct heat at high temperatures (500°F+).

1. Prepare up to 3 lbs (approximately 50-60 briquettes) of charcoal spread evenly across all 3 Wood Product Zones.
2. Using the Flavor Drawer™ Operation instructions, follow the steps for lighting the charcoal and bring to temperature. You may also use the gas burners as necessary to assist in controlling the desired temperature.
3. Once the grill is to desired temperature, you may begin to cook. Food will cook quickly. Cook each side 3-4 minutes and then bring to desired internal temperature.
4. NOTE: Water soaked wood chips, chunks or logs may be used in addition to charcoal to add smoke flavor as desired.

## SEAR (HI-TEMP DIRECT HEAT) - 500°F+

Up to 3 lbs. Charcoal (50-60 Briquettes)

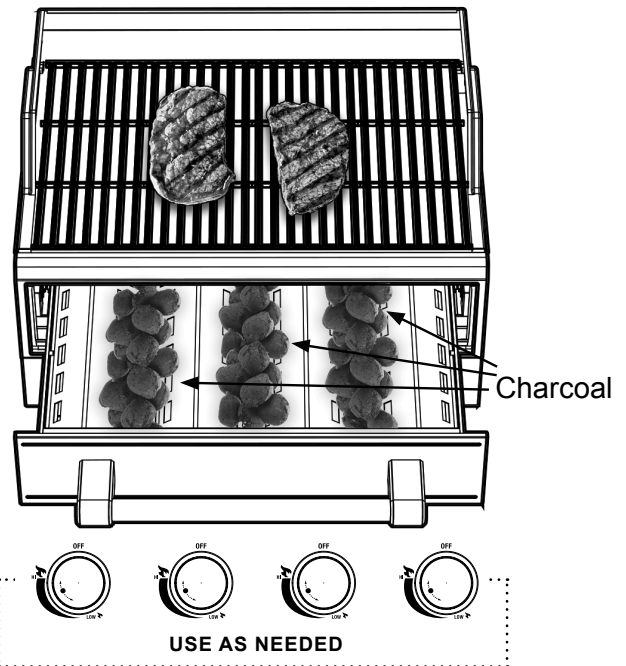

## Smoke

Cook with indirect heat at low temperatures (150°-250° F). Use wood chips, chunks, logs or pellets to add smoke flavor (recommended quantities and gas temperatures below).

1. Using chart above, open Flavor Drawer™ and add desired wood type to right most Wood Product Zone.
2. Using the Gas Operation instructions, follow the steps for lighting the 2 Main Burners on the right side of the grill and then set to LOW to MED/LOW according to chart above.
3. Use gas burners to control temperature, making sure to avoid wood erupting in open flame. The 2 gas burners on right side may be turned on and off as necessary to control temperature.
4. Once wood chips, chunks, logs, or pellets are smoldering and grill is to desired temperature, you may begin to cook.
5. NOTE: Ensure food is placed on the opposite side of the grill from the source of smoke (see illustration to right).

## SMOKE (INDIRECT HEAT) - 150-250°F

Up to 1 lbs. Wood Fuel (4-5 Chunks)

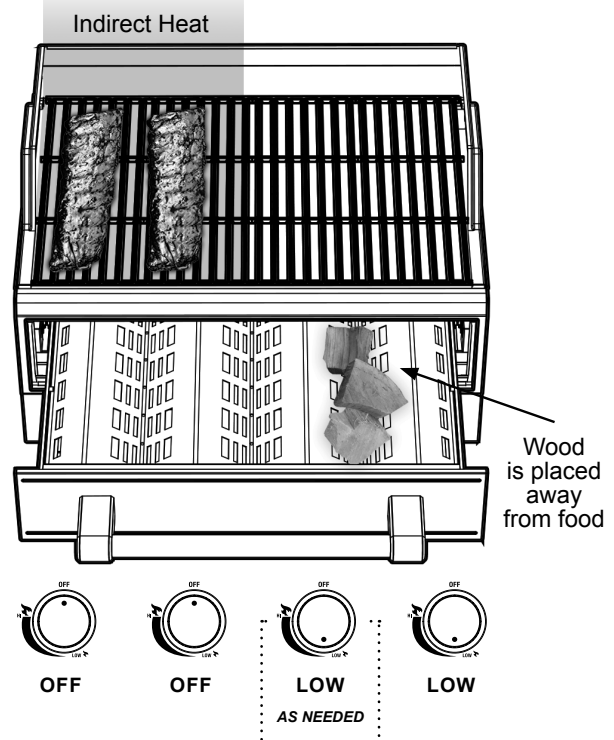







# ENHANCE FLAVOR

## Wood Pairing Guide

Different wood varieties possess different flavors and Char-Griller recommends pairing your woods with the meats you intend to cook.

WOOD	FLAVOR	 BEEF	 PORK	 POULTRY	 SEAFOOD	 VEGGIES
ALDER	MILD			✓	✓	
MAPLE	MILD			✓		✓
CHERRY	MILD		✓	✓	✓	
APPLE	MEDIUM	✓	✓	✓	✓	
PECAN	MEDIUM	✓	✓	✓	✓	✓
OAK	MEDIUM	✓	✓	✓	✓	✓
HICKORY	STRONG	✓	✓			
MESQUITE	STRONG	✓	✓			



## **FLAVOR PRO™ TIPS**

- Control heat by adjusting the gas burner knobs, the amount and type of fuel as well as the adjustable smokestacks. Wood burns hotter than coals. More airflow helps generate more heat. Open smokestacks by rotating counterclockwise, close smokestacks by rotating clockwise. CAUTION: Smokestack caps will be hot. Only touch using gloves or mitts.
- Additional charcoal and/or smoking woods may be added to the Flavor Drawer™ while cook is in progress. Wear gloves and apron when operating Flavor Drawer™ and ensure your surroundings are clear. Open Flavor Drawer™ slowly.
- Soaking wood prior to smoking in Flavor Drawer™ will delay smoke until later in the cook. The longer the soak prior to cook (up to maximum saturation), the longer the delay.
- Only use food-grade pellets or natural hardwoods intend for cooking. Appropriate selections can typically found in grocery stores and outdoor grilling retailers.
- Use care when smoking, woods should SMOLDER, not erupt in open flame. Flaming wood may cause damage to grill if temperatures exceed 650°F.
- Gas burners may be utilized in conjunction with solid fuels to accelerate temperatures and/or cook time.
- To reduce flare-ups, cook with hood in the down position.
- When cooking with charcoal, leave the grill hood open during the initial start up and until coals ash over. The grill hood must remain open anytime the temperature gauge is greater than 650°F.
- Ashes left in grill too long between uses will absorb moisture and will cause rust. Be sure to empty ash after grill has cooled. Uncoated steel and cast-iron will rust when not properly cared for.
- Do not use self-starting charcoal as it will give unnatural flavor.
- After each use, coat the interior grates and bare metal with vegetable oil while warm to reduce the chance of rust.
- On the EXTERIOR PAINT, remove rust with wire brush and touch up with a high heat paint, available at most hardware/auto stores.
- Heat gauge may retain moisture, which will steam out during cooking. Gauge can be removed and calibrated in oven.
- You may fill unwanted holes with Nuts & Bolts (Not Provided).

**NOTE: Smoke may escape from areas other than the smokestack. This will not affect cooking.**

**This Page Intentionally  
Left Blank**

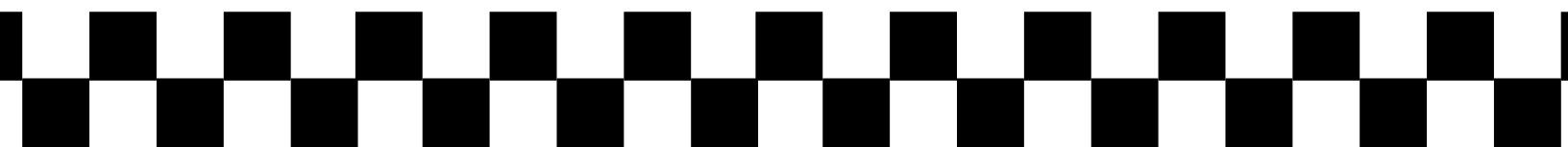

# GRILLING RECIPES

## Direct Heat

**Direct Heat is a high heat method used to cook foods that take less than 25 minutes to cook. Typically, this means foods that are relatively small or thin, such as steaks, chops, boneless chicken breasts, fish fillets, hamburgers, etc.**

- Cooking with a MEAT THERMOMETER ensures food is fully cooked. Insert thermometer into the thickest part of the meat, not touching bone, and allow 1 to 1 1/2 minutes to register temperature.
- Internal temperatures for BIRDS should be 170°F to 180°F or when leg moves easily in joint.
- Internal temperature for meat should be 140°F for rare, 160°F medium, and 170°F for well done.

### **STEAK (& ALL MEATS):**

- To grill meats, set the grill to high heat and sear for one minute on each side with the lid open to seal in flavor and juices. Then lower the heat to medium, close the lid, and cook to desired temperature.

**Tip:** Place grilled meat back in the marinade for several minutes before serving – it will become tastier and juicier.

**CAUTION:** Boil extra marinade first to kill bacteria remaining from the raw meat.

### **MARINATED FLANK STEAK:**

- Mix marinade ingredients in nonmetal dish.
- Let steak stand in marinade for no less than 4 hours in refrigerator.
- Sear each side on high heat for 5 minutes; center should remain rare.
- Cut steak diagonally across the grain into thin slices before serving.

### **Meat Marinade**

1/2 cup Olive Oil  
1/3 cup Soy Sauce  
1/4 cup Red Wine Vinegar  
2 tbsp Lemon Juice  
1 tsp Dry Mustard  
1 minced Garlic Clove  
1 small Onion, minced  
1/4 tsp Pepper





### **QUAIL OR DOVES:**

- Cover birds in Italian dressing (Good Seasons or Kraft Zesty) and marinate overnight.
- Pour remaining dressing and cover with preferred hot sauce. Marinate for 6 hours.
- Wrap birds in thick bacon, and secure with a toothpick.
- Place on grill. Keep turning until bacon is charred.
- Grill for 20 minutes. Sear on high with lid open for 1 minute on each side before lowering heat and closing lid.

### **KABOBS:**

- Alternating on skewers any combination of meat, onions, tomatoes, green peppers, mushrooms, zucchini, circular slice of corn-on-the-cob, or pineapple. Meat could consist of chunks of shrimp, scallops, lobster, chicken, sausage, pork, beef, etc.
- Marinate the meat in refrigerator for several hours.
- Grill each side approximately 7 minutes turning occasionally while basting with marinade. Leave a small amount of room between pieces in order to cook faster.
- Grill with lid open. See marinade recipe on last page.

### **Kabob Marinade:**

1 cup Soy Sauce  
½ cup Brown Sugar  
½ cup Red Wine Vinegar  
½ cup Pineapple Juice  
2 tsp Salt  
½ tsp Garlic Powder

- Mix all ingredients in a saucepan and bring to boil.
- Allow marinade to cool before marinating your meat in it.
- Marinate beef in mixture a minimum of 4 hours.

### **HOT DOGS:**

- Grill with lid open for approximately 6 minutes.
- Turn every few minutes.

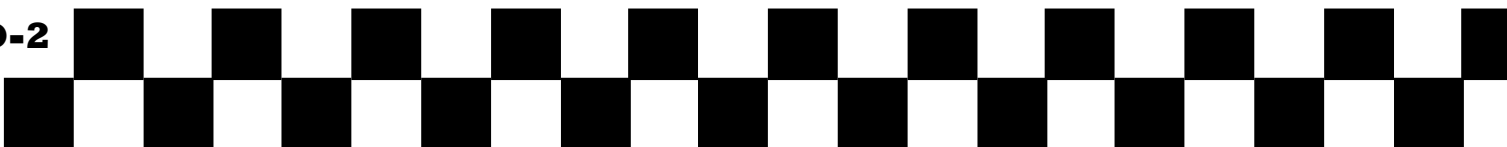

## **HAMBURGERS:**

See Meat Marinade on previous pages.

You may also marinate by allowing to stand in marinade for 1 or 2 hours at room temperature before cooking, or let stand in covered dish in refrigerator up to 24 hours.

- Bring to room temperature before cooking.
- Mix in chopped onions, green peppers, salt, sear 3/4 inch patties on each side.
- Cook over medium heat with lid down to avoid flare-ups.
- Cook each side 3 to 7 minutes according to desired temperature.
- Cook ground meat to 150°F internally or until juice runs clear (free of blood) for prevention of E. coli.
- Burgers can be basted with marinade when turning and/or other ingredients can be mixed in with the ground beef such as chili sauce or powder.

## **SHRIMP (Peeled) & CRAYFISH:**

- Place on skewers.
- Coat with melted butter and garlic salt.
- Grill 4 minutes on each side or until pink. Cocktail sauce optional.

## **BAKED POTATOES:**

- Rub with butter and wrap in foil and cook on grill with lid down for 50 minutes.
- Turn after 25 minutes (no need to turn if smoked).
- Squeeze to check for doneness.

## **SWEET CORN IN HUSKS:**

- Trim excess silk from end and soak in cold salted water 1 hour before grilling.
- Grill 25 minutes – turning several times.



# SMOKING RECIPES

## Indirect Heat

### SMOKING TIMES

Food	Weight	Water Pan Smokin'	Temperature on Meat Thermometer
Beef Roasts, Beef Brisket	3 – 4 lbs.	1 – 1½ hours	140° rare
Lamb Roasts, Venison	5 – 7 lbs.	1¾ – 2½ hours	160° medium
Large cuts of Game	7 – 9 lbs.	2½ – 3½ hours	170° well done
Pork Roasts	3 – 4 lbs. 5 – 8 lbs.	1¾ – 2½ hours 2½ – 3 hours	170° 170°
Pork/ Beef Ribs	Full grill	1½ – 2 hours	Meat pulls from bone
Pork Chops	Full grill	¾ – 1¼ hour	Meat pulls from bone
Sausage Links	Full grill	2 – 2¾ hours	170° for fresh sausage
Ham, Fresh	10 lbs.	3 – 4 hours	170°
Ham, Cooked	All sizes	1½ – 2 hours	130°
Chicken (Cut up or split)	1-4 fryers, cut up or split	1 – 1¼ hours	180° / leg moves easily in joint
Chicken (Whole)	1-4 fryers	1¼ – 1½ hour	180° / leg moves easily in joint
Turkey (Unstuffed)	8 – 12 lbs.	1¾ – 2½ hours	180° / leg moves easily in joint
Fish, small whole	Full grill	½ – ¾ hours	Flakes with fork
Fish, filets, steak	Full grill	¼ – ½ hours	Flakes with fork
Duck	3 – 5 lbs.	1 – 1¾ hours	180° / leg moves easily in joint
Small game birds	Full grill	¾ – 1 hour	180° / leg moves easily in joint

Pan not included. SMOKE BY COOKING SLOWLY.

1. Place water pan in the middle of the grill.
2. Light the left-most or right-most burner which will serve as your heat source.
3. Place solid fuels in the Flavor Drawer's™ wood product zone above that burner.
4. Add meat on the opposite side of your heat source.

**Tip:** Check the water level when cooking more than 4 hours or when you can't hear the water simmering. Add water when necessary.

### SMOKED TURKEY:

- Empty cavity rinse and pat dry with paper towel.
- Tuck wing tips under the back and tie legs together.
- Place in center of cooking grate directly above foil drip pan of water.
- Smoke for 12 minutes per pound. Allow several extra minutes per pound if stuffed to allow for expansion.
- Use a meat thermometer for best results (190°F internal).

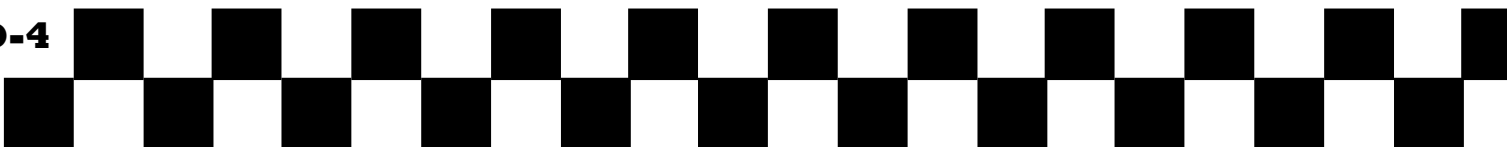

## **SMOKED BAKED HAM:**

You can smoke fully cooked canned ham or smoked and cured whole ham or shank or butt portion.

### **Glaze**

1 cup of Light Brown Sugar, firmly packed  
1/2 cup Orange Juice  
1/2 cup Honey

- Combine sugar, juice and honey. Let glaze sit for at least 4 hours.
- Remove rind and score fat diagonally to give a diamond effect.
- Insert a whole clove into the center of every diamond.
- Place ham with fat side up in center of cooking grate. Close lid.
- About 9 minutes per pound is suggested for fully cooked hams. Smoked or cured ham, which is not fully cooked, should be cooked to an internal temperature of 160°F.
- Baste with ham glaze 3 or 4 times during last 30 minutes of cooking time.
- Garnish with pineapple rings about 15 minutes before end of cooking time.

## **SMOKED STUFFED HOT DOGS:**

- Slit hot dogs lengthwise, within 1/4 inch of each end.
- Stuff hot dogs with cheese and relish and wrap in bacon.
- Place on cooking grate over drip pan and smoke 15-20 minutes or until bacon is crisp.

## **SMOKED CHICKEN PARTS AND HALVES:**

- Rinse pieces in cold water and pat dry with paper towels.
- Brush each piece with Olive Oil and season to taste with salt and pepper.
- Brown pieces directly above coals with lid open and grill on high or medium heat for several minutes.
- Then place pieces on cooking grate in indirect cooking area.
- With the grill on low heat, cook with lid down for 55 to 60 minutes or until done. Do not use Olive Oil or salt and pepper if using marinade.

## **SMOKED VENISON WITH BACON:**

### **Venison Marinade:**

1 cup Balsamic or Red Wine Vinegar  
1 cup Olive Oil  
2 oz. Worcestershire  
1/2 oz. Tabasco  
2 tbsp. Seasoning Salt  
1-2 chopped Jalapeños  
3 oz. Soy Sauce



### **Bacon Marinade (for Smoked Venison with Bacon Recipe)**

2 oz. Red Wine Vinegar  
2 oz. Worcestershire  
4 dashes Tabasco

- Place leg of venison in a container and marinate for 2-4 days, turning daily. Leave bacon to marinate overnight.
- Remove leg from refrigerator at least an hour before cooking.
- Season generously with seasoned salt and coarse ground black pepper.
- Wrap 1 lb. bacon over the top of the leg, and smoke 20-25 minutes per pound, or until tender. Do not overcook.

### **SMOKED SHRIMP & CRAYFISH:**

- Mix in a foil pan 1/2 cup butter, two cloves of crushed garlic, Tabasco, sliced green pepper, 1 tablespoon each of minced onions, salt and juices from one lemon.
- Add shrimp and/or crayfish and smoke 45 minutes.

### **SMOKED VEGETABLES:**

- Turnips, potatoes, carrots, okra, mushrooms, peeled onions, zucchini, squash, etc.
- Put in pan and cover with water and cook for several hours while cooking the meat. Or place vegetables on grill and smoke for 50 minutes, either wrapped in foil or not.

### **SMOKED FISH:**

- Marinate in brine (1/4 cup dissolved in 1 qt of water) or marinate fish in 1 cup white wine, 1 cup Soy Sauce mixed with 1 cup Lemon Juice.
- Marinate overnight in covered dish in refrigerator.
- Let air on rack 20 minutes before placing on Pam-sprayed grill.
- Smoke 25 minutes.

### **SMOKED SPARE/BACK RIBS:**

- Peel off tough layer of skin on back side.
- Rub all surfaces with seasoning.
- Place ribs in the indirect cooking area and smoke approximately 1 1/2 hours or until meat pulls away from bone.
- Baste with barbecue sauce during last 30 minutes.

## **CHICKEN MARINADE:**

### **Combine**

1/2 cup Soy Sauce  
1/4 cup Olive Oil  
1/4 cup Red Wine Vinegar  
1 teaspoon Oregano  
1/2 teaspoon Sweet Basil  
1/2 teaspoon Garlic Powder with Parsley  
1/4 teaspoon Pepper

- Pour over chicken pieces in non-metal dish
- Cover and refrigerate overnight, turning occasionally. Use marinade to baste chicken while cooking.

## **MEAT MARINADE:** (For steaks, chops, and burgers)

### **Combine**

¼ cup Soy Sauce  
2 coarsely chopped Large Onions  
2 Garlic Cloves (halved)

- Combine ingredients in an electric blender, cover, and process at high speed 1 minute or until mixture is very smooth.
- Stir in 1/4 cup bottle gravy coloring (Kitchen Bouquet and Gravy Master) and 2 teaspoons Beau Monde seasoning (or substitute 1 teaspoon MSG and 1 teaspoon seasoned salt).
- Allow meat to stand in marinade at room temperature for 2 hours or refrigerate up to 24 hours in a covered dish.
- Bring meat to room temperature before cooking.

## **SHISH KABOB MARINADE:**

### **Combine**

1 cup Soy Sauce  
1/2 cup Brown Sugar  
1/2 cup White Vinegar  
1/2 cup Pineapple Juice  
2 teaspoons Salt  
1/2 teaspoon Garlic Powder

- Mix ingredients and bring to a boil.
- Marinate beef in mixture a minimum of 4 hours.

# ACCESSORIES



## Custom Fit Cover

Weather Resistant  
Protects Grill Finish  
Cover Accommodates Side  
Shelf or Side Fire Box



## Tank Cover

Weather Resistant  
Nylon Velcro  
Elastic at Top and Bottom  
Cover Only  
Tank Not Included



## Folding Probe Thermometer

Stainless steel  
fast-read probe accurately  
measures temperature  
Easily switch from °F to °C  
Auto ON/OFF feature for  
extended battery life



## Apron

Machine Washable  
Two Front Pockets  
Adjustable Straps



## Char-Griller® Trucker Hat

Cotton-poly blended front  
Nylon mesh back  
Adjustable snapback closure  
One Size Fits Most



## Original All-Purpose BBQ Rub

Pairs well with all types  
of meat and fish

**For pricing or to order accessories visit:**

**[www.CharGriller.com](http://www.CharGriller.com)**

**OR**

**CALL: 912-638-4724**



**P.O. Box 30864  
Sea Island, GA 31561  
912-638-4724  
[www.CharGriller.com](http://www.CharGriller.com)  
[Service@CharGriller.com](mailto:Service@CharGriller.com)**

