

6822-167-PG-BB Extra-Wide Clothes Closet

©2019 Whitmor, Inc.



A1 4 ea
Side supports



B 4 ea
Female tubes



E 1 ea
Female rod



C 4 ea
Male tubes



F 1 ea
Male rod

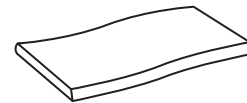

G 1 ea
Cover



A2 2 ea
Center supports



D 6 ea
Vertical tubes

Part	Reference
A1	F9376
A2	F9377
B	F9378
C	F9379
D	F9380
E	F9381
F	F9382
G	F9383

Recommended: 2 people assembly. **Tools Needed:** No tools required.

NOTE: All metal parts must be inserted firmly and completely into the plastic parts.

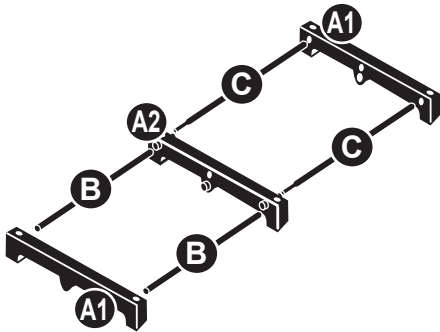

Bottom frame assembly: Insert two female tubes (**B**) into the holes on the side (see image above). Then place the other side of the female tubes (**B**) through the holes on the stickered side of the center support (**A2**). Insert two male tubes (**C**) into the center support (**A2**) where the tubes intersect. Place another side support (**A1**) onto the ends of the tubes.

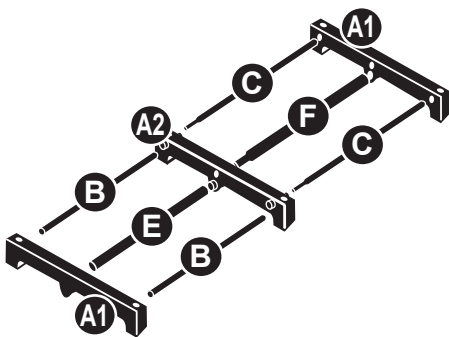

Top frame assembly: Insert two female tubes (**B**) into the side support (**A1**). Insert the female rod (**E**) into the center of side support (**A1**). Then place the other side of the female tubes (**B**) and female rod (**E**) through the holes on the stickered side of the center support (**A2**). Insert two male tubes (**C**) and the male rod (**F**) into center support (**A2**) where tubes intersect. Place another side support (**A1**) onto the ends of the tubes.

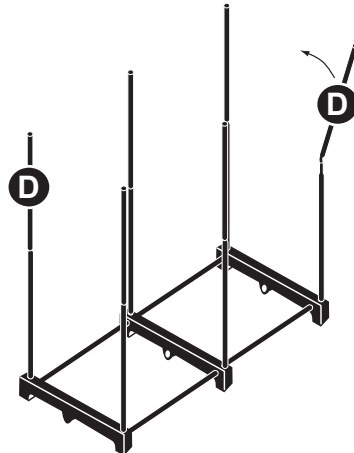

STEP 1: Insert the tapered side of each vertical tubes (**D**) into bottom frame. Unfold and straighten the vertical tubes (**D**).

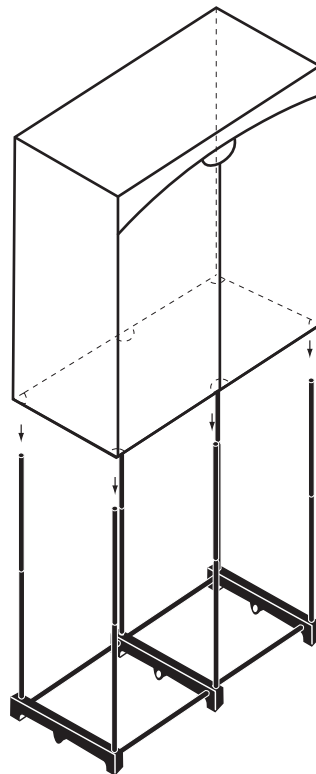

STEP 2: Unfold the cover, note the placement of six holes in the bottom of the cover. Carefully fit the holes over the vertical tubes (**D**). **NOTE:** do not slide the cover all the way down.

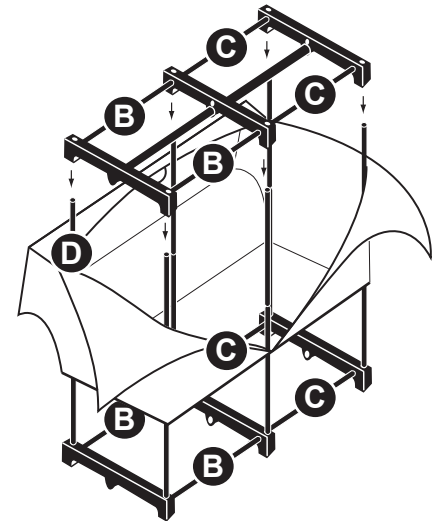

STEP 3: Unzip the zippers. Allow the top of the cover fall back revealing the ends of the vertical tubes (**D**). To install assembled top frame - make sure female tubes (**B**) on the top frame are above female tubes (**B**) on the bottom frame. Starting from one end press down on each tube firmly to attach top frame.

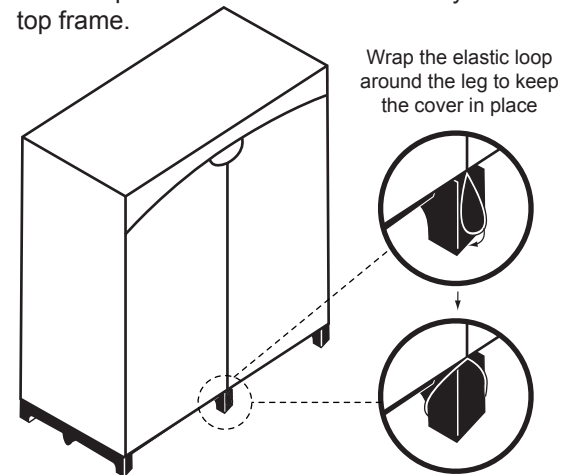

STEP 4: Lift cover up over the top of the frame, carefully fitting the corners of the cover over the top corners of the frame. Slide the bottom of the cover downwards evenly to the base of the frame.

8680 Swinnea Road • Suite 103 • Southaven, MS • 38671

NEED HELP? For help with assembly, or if you are missing a part, please call Whitmor's Consumer Care Team, 1-888-944-8667 between 8 a.m. and 4:30 p.m. (Central Standard Time) Monday through Friday. Or email: help@whitmor.com. Visit us online at www.whitmor.com