

# Cub Cadet®



## **CC-1000PS** **15 cu ft POLY SWIVEL DUMP CART**

U.S. Patent No. 8,496,298 & 9,242,588



**READ AND FOLLOW ALL SAFETY RULES AND OPERATING  
INSTRUCTIONS BEFORE USING THIS EQUIPMENT**

# ***Safety Rules***



**This is the safety alert symbol. It is used to alert you to potential personal injury hazards. Obey all safety messages that follow this symbol to avoid possible injury or death.**

Read and understand all safety rules and operating instructions before using this tractor attachment.

Follow all safety rules and operating instructions provided by your vehicle's manufacturer when using attachment.

Never allow children or untrained persons to operate vehicle or attachment.

Do not exceed the vehicle manufacturer's towed weight limit.

Reduce vehicle speed and allow extra stopping distance when towing heavy loads.

Reduce vehicle speed and towed weight when operating on slopes.

Operate up and down slopes, never across the face of slopes.

Do not carry passengers on vehicle or attachment.

Avoid sudden turns or maneuvers.

Do not tow attachment on public roadways.

Do not remove warning decals from product.

Check product for worn, loose, or damaged parts before each use. If any damage is present, repair the product before using.

Check product for loose or missing fasteners before each use. Tighten or replace fasteners as needed before using.

Do not exceed vehicle speed of 6 miles per hour when towing Dump Cart.

Do not exceed Dump Cart rated weight capacity of 1000 pounds.

# Carton Contents

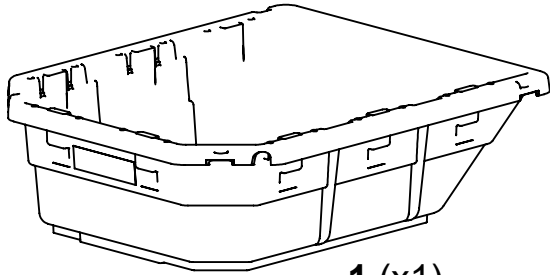

1 (x1)

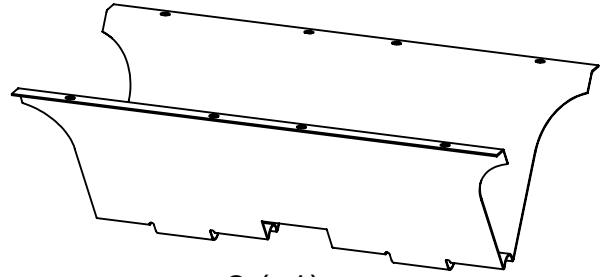

2 (x1)

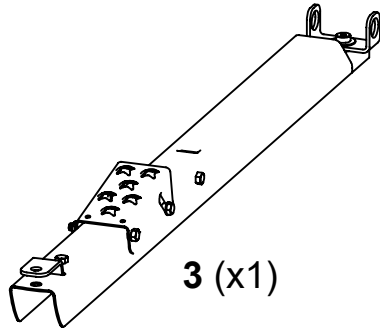

3 (x1)

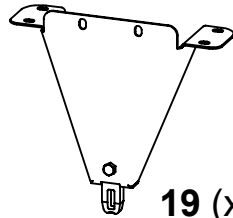

19 (x1)

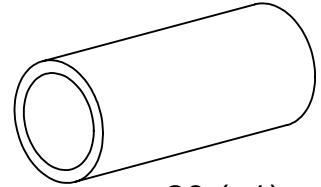

20 (x1)

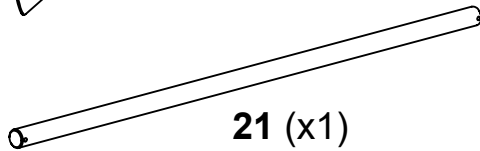

21 (x1)

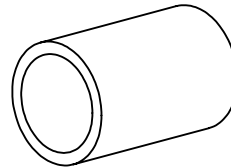

22 (x2)

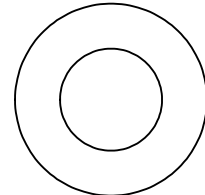

23 (x4)

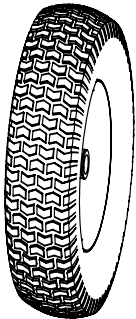

24 (x2)

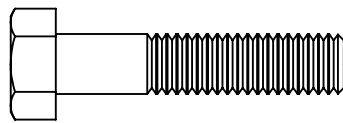

25 (x12)

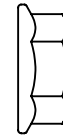

26 (x12)

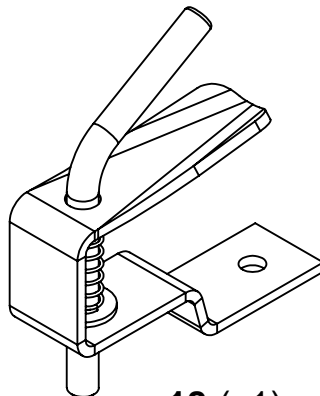

18 (x1)

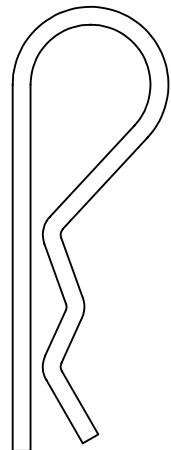

27 (x2)

## TOOLS REQUIRED FOR ASSEMBLY:

- 1/2" Wrench or Socket
- Grease Gun

# Assembly Instructions

**1**

Attach Undercarriage to Poly Body and tighten hardware.

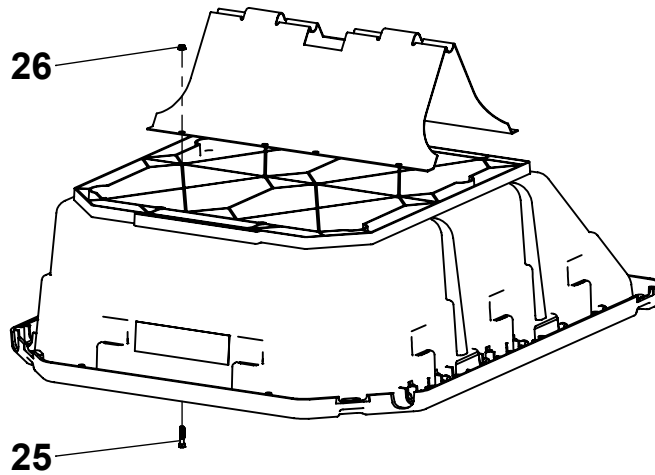

**2**

Attach Front Support to Poly Body and tighten hardware.

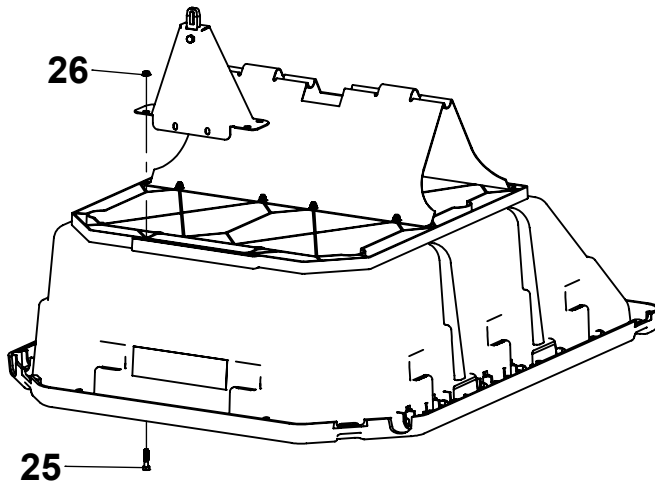

**3**

Insert Axle into Undercarriage halfway as shown. Center Spacer inside Swivel Clevis and align with Axle.

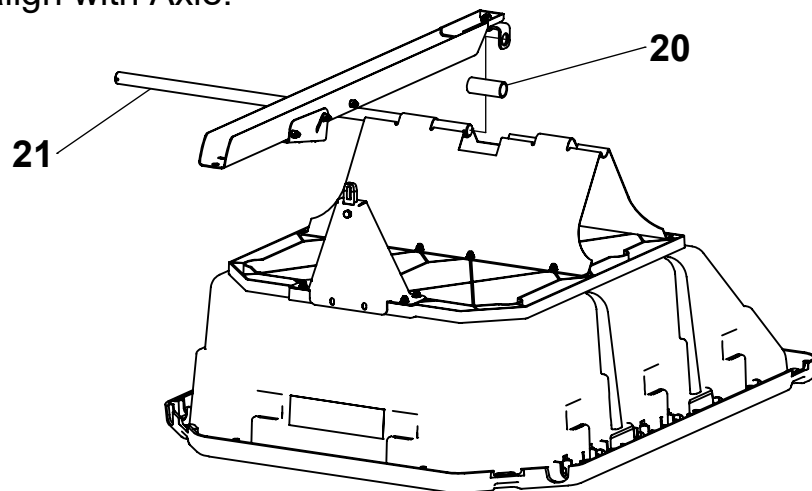

# Assembly Instructions

**4**

Slide Axle completely through Undercarriage; Swivel Clevis and Spacer must be captured by Axle. Align Drawbar with Front Support and press down to latch.

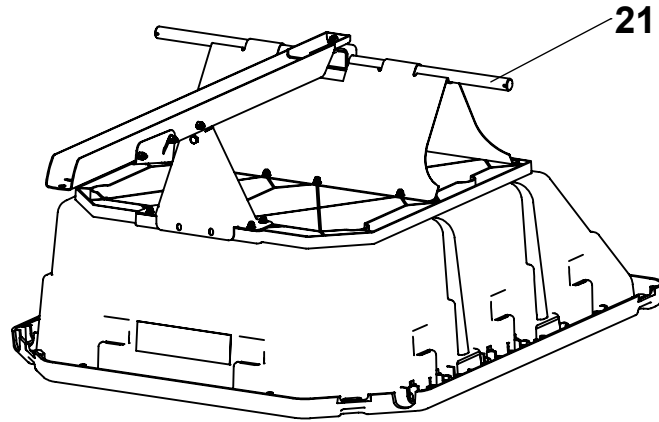

**5**

Slide in order: 1" Washers, 2" Spacers and then Wheels onto Axle and secure with Hairpins.

**NOTE:**  
WHEELS IN MODEL  
NOT SHOWN TO SCALE

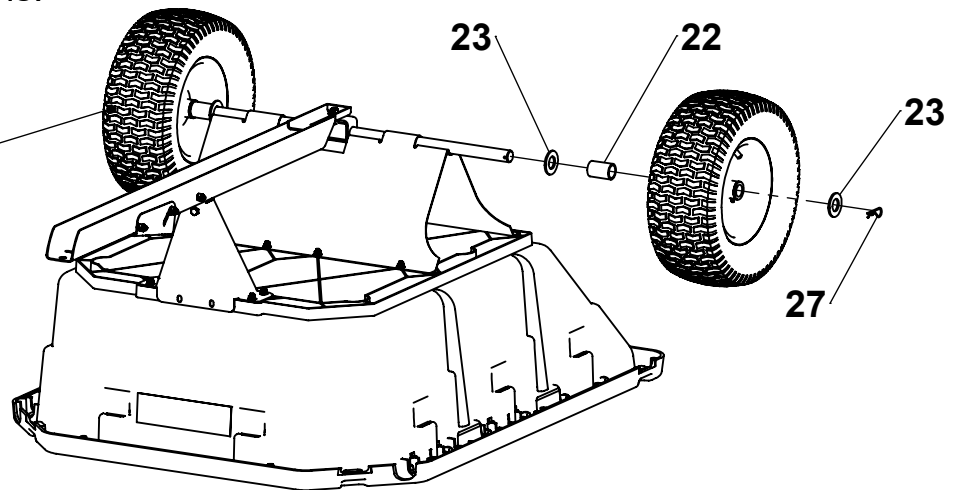

**6**

Install Spring-loaded Hitch Pin as shown.

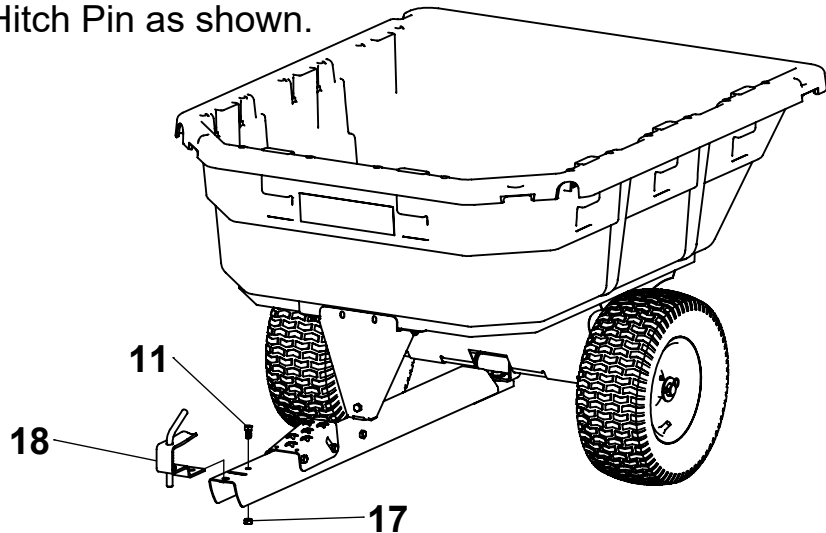

# ***Operating Instructions***

## **Before Using Dump Cart:**

1. Apply grease to wheels using grease gun until grease can be seen squeezing out from both sides of the wheel.
2. Check tire pressure and inflate to 28 psi if needed.
3. Read all Safety Rules found on page 1.

## **How to Use Dump Cart:**

1. Attach Dump Cart to your tractor using the supplied hitch pin.
2. Do not exceed 1000 pounds when loading material into the cart body.
3. Distribute the weight of the load as evenly as possible in the cart body for best handling.
4. When hauling heavy loads, verify that your vehicle has adequate towing and braking capacity.
5. Do not exceed 6 miles per hour when towing Dump Cart.

## **How to Empty Dump Cart:**

1. Step down the foot pedal to release the latch mechanism.
2. Lift the body and swivel as desired to guide the material to preferred location.
3. Lift the body entirely and empty material.
4. Lower the body and guide the latch into the drawbar and relatch.

## **Periodic Maintenance:**

- Tighten fasteners as needed before each use
- Check tire pressure before each use
- Grease wheels annually

# Do-It-Yourself Accessories

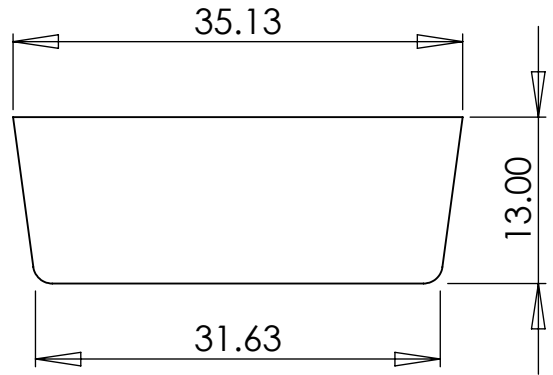
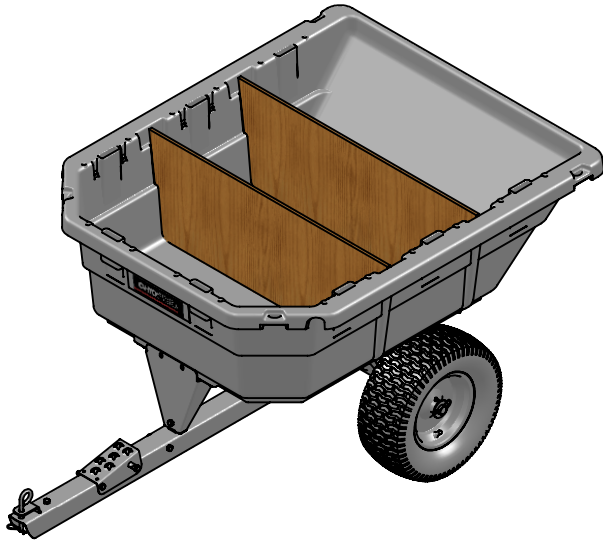

USE 1/2" PLYWOOD

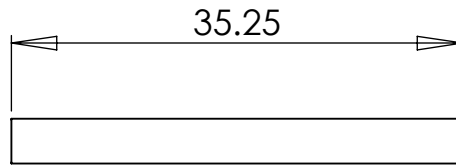
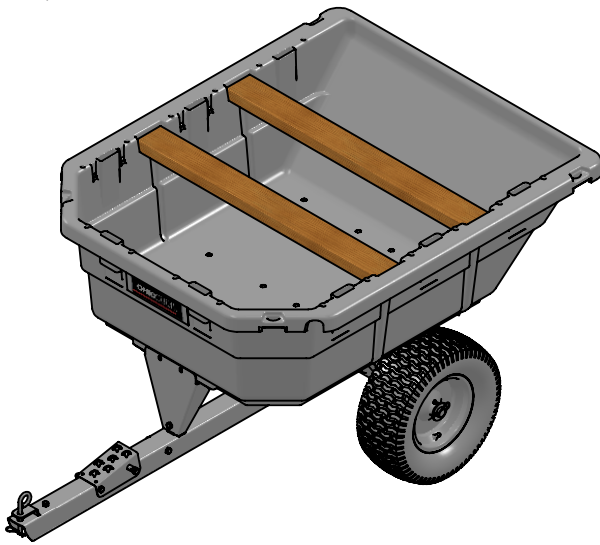

USE STANDARD 2 X 4

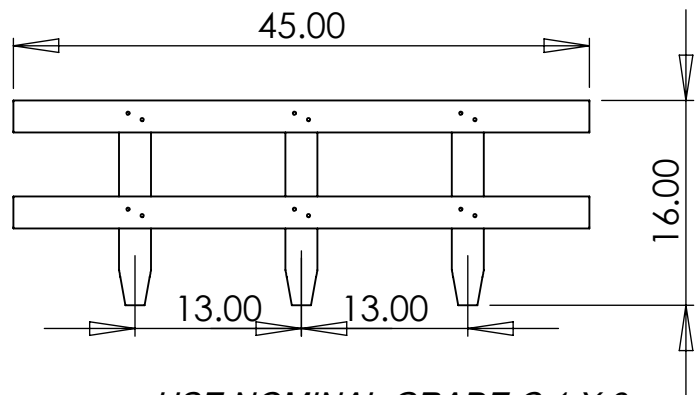
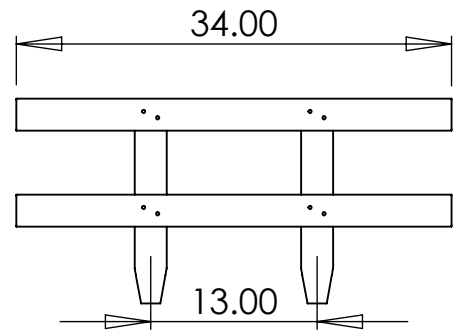
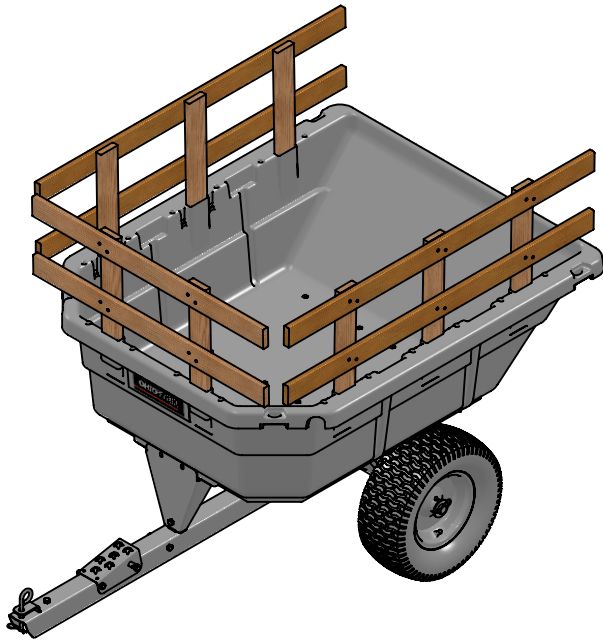

USE NOMINAL GRADE C 1 X 3

# Warranty

If this product fails due to a defect in material or workmanship within THREE YEARS from the date of purchase, we will at our option repair or replace it free of charge. This warranty excludes tires and wheels which are expendable and become worn during normal use.

**This warranty does not cover:**

- Repairs necessary because of operator abuse or negligence.
- Equipment used for commercial or rental purposes.
- Paint that is worn or faded due to normal use or exposure.

To arrange for product repair you can call 1-800-652-2321 to speak to our Customer Service Team, or return this product to place of purchase for replacement.

This warranty gives you specific legal rights, and you may also have other rights which may vary from state to state. This warranty applies only while this product is in use in the United States.

In the space below record the purchase date of your Lawn Sweeper.

Model Number CC-1000PS

Purchase Date \_\_\_\_\_

Retailer/Dealer \_\_\_\_\_

Purchase Price \_\_\_\_\_

Keep this Owner's Manual and your receipt in a safe place for future reference. Replacement parts may be ordered by calling **1-800-652-2321** .

When ordering replacement parts, always give the following information:

- Product 15 cu ft POLY SWIVEL DUMP CART
- Model Number CC-1000PS
- Part Number \_\_\_\_\_
- Part Description \_\_\_\_\_



# EXPLODED VIEW

**NOTE:**

WHEELS IN MODEL  
NOT SHOWN TO SCALE

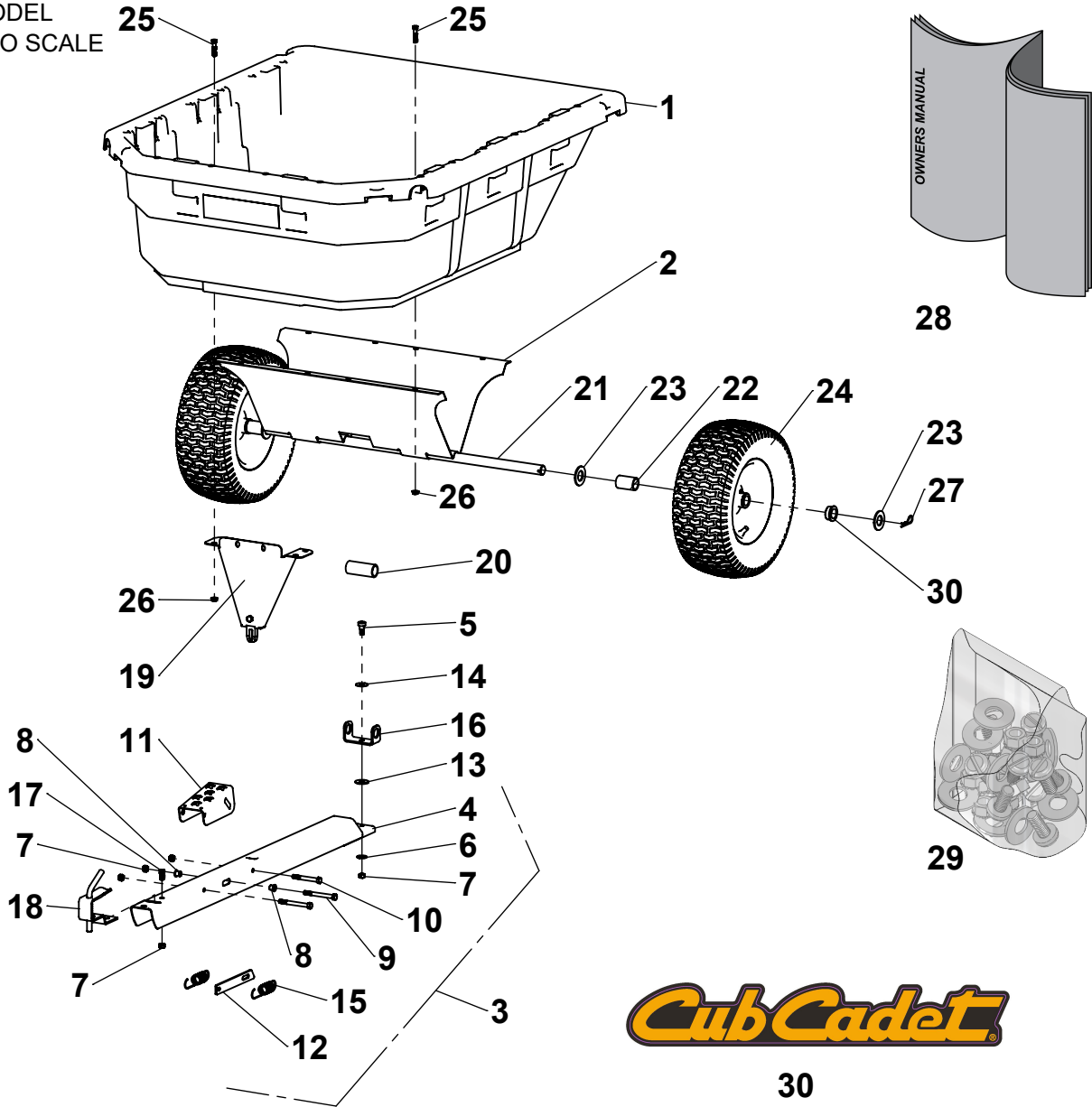

| ITEM | PART NO   | DESCRIPTION                  | QTY | ITEM | PART NO   | DESCRIPTION               | QTY |
|------|-----------|------------------------------|-----|------|-----------|---------------------------|-----|
| 1    | 311161    | Poly Body                    | 1   | 17   | 300052    | 3/8-16 x 3/4" Hex Bolt    | 1   |
| 2    | 6000404   | Undercarriage                | 1   | 18   | 6000612   | Spring Loaded Hitch Pin   | 1   |
| 3    | 6001663   | Drawbar Assembly (incl 4-16) | 1   | 19   | 6000310   | Front Support             | 1   |
| 4    | 6000383   | Welded Drawbar               | 1   | 20   | 6000463   | 3-1/8" Spacer             | 1   |
| 5    | 6000369   | Shoulder Bolt                | 1   | 21   | 300002    | Axle                      | 1   |
| 6    | 3000720   | 3/8" USS Flat Washer         | 1   | 22   | 6000382   | 2" Spacer                 | 2   |
| 7    | 300061    | 3/8-16 C-Lock Nut            | 5   | 23   | 300076    | 1" SAE Flat Washer        | 4   |
| 8    | 6000324   | Bushing                      | 2   | 24   | 6002415-1 | Wheel                     | 2   |
| 9    | 6000370   | 3/8-16 x 3-1/2" Hex Bolt     | 2   | 25   | 3000528   | 5/16-18 x 1-1/2" Hex Bolt | 12  |
| 10   | 300055    | 3/8-16 x 3" Hex Bolt         | 1   | 26   | 6000419   | 5/16-18 Flange Lock Nut   | 12  |
| 11   | 6000305-Y | Foot Pedal                   | 1   | 27   | 300084    | Hairpin Cotter, 2-5/16"   | 2   |
| 12   | 6000309   | Latch                        | 1   | 28   | 6004279   | Owners Manual             | 1   |
| 13   | 300075    | 1/2" USS Washer              | 1   | 29   | 6001667   | Hardware Bolt Bag         | 1   |
| 14   | 6000368   | Spring Washer                | 1   | 30   | 777D21641 | Decal, Cub Cadet          | 1   |
| 15   | 6000325   | Latch Spring                 | 2   |      |           |                           |     |
| 16   | 6000312   | Swivel Clevis                | 1   |      |           |                           |     |

# **REPAIR KITS**

| <b>KIT</b>           | <b>KIT NUMBER</b> | <b>PART NUMBER</b> | <b>PART DESCRIPTION</b>          | <b>QTY</b> |
|----------------------|-------------------|--------------------|----------------------------------|------------|
| HARDWARE BOLT BAG    | 6001667           | 3000528            | 5/16-18 X1-1/2" HEX HEAD BOLT    | 12         |
|                      |                   | 6000419            | 5/16-18 X1-1/2" SPINNER-GRIP NUT | 12         |
|                      |                   | 300076             | 1" SAE WASHER                    | 4          |
|                      |                   | 300084             | HAIRPIN COTTER, 0.093" X 2-5/16" | 2          |
|                      |                   | 300052             | 3/8-16 X3/4" HEX BOLT            | 1          |
|                      |                   | 300061             | 3/8-16 X3/4" C-LOCK NUT          | 1          |
|                      |                   | 6000382            | 1" SPACER X 2"                   | 2          |
|                      |                   | 6000463            | 1" SPACER X 3-1/8"               | 1          |
| 1" WHEEL BUSHING KIT | 6000810           | 6000808            | 1" WHEEL BUSHING                 | 4          |
| Drawbar Assembly     | 6001663           | 300055             | HEX BOLT, 3/8-16 X 3-1/2"        | 1          |
|                      |                   | 300061             | HEX NUT, 3/8-16 C-LOCK           | 4          |
|                      |                   | 300075             | WASHER, 1/2" USS                 | 1          |
|                      |                   | 3000720            | WASHER, 3/8" USS                 | 1          |
|                      |                   | 6000305-Y          | FOOT PEDAL                       | 1          |
|                      |                   | 6000309            | LATCH                            | 1          |
|                      |                   | 6000312            | CLEVIS, SWIVEL                   | 1          |
|                      |                   | 6000324            | BEARING                          | 2          |
|                      |                   | 6000325            | SPRING, LATCH                    | 2          |
|                      |                   | 6000368            | WASHER, SPRING                   | 1          |
|                      |                   | 6000369            | SHOULDER BOLT, 1/2" X 3/8"       | 1          |
|                      |                   | 6000370            | HEX BOLT, 3/8-16 X 3-1/2"        | 2          |
|                      |                   | 6000383            | WELDED DRAWBAR                   | 1          |

## **Customer Service 1-800-652-2321**

1. A description of the issue you are having
2. Photos of the issue that include an overall view and detailed view from multiple angles
3. If applicable, a short video showing the issue

**If you believe this is a warranty related issue please see the warranty page in this manual**

### **Replacement Parts:**

**If you are ordering replacement part(s) for your product, please note that some parts are only available as a repair kit. You can reach our Customer Service Department at 1-800-652-2321**

1. First locate the part on the Exploded View page (page8)
2. Take note of the part number
3. If the part number is on the Repair Kits page, use the kit number to order your replacement parts
4. If the part number is not on the Repair Kits page, use the part number to order your replacement part

Designed And Tested In Columbus, Ohio  
Manufactured In The U.S.A. From Domestic  
And Imported Components



**MODEL # CC-1000PS**

(800) 652-2321

**(800) 652-2321**