

REPAIR SHEET

BRAND RYOBI		DESCRIPTION 18 Volt Brushless Power Head
MODEL NO. P20104 P20104VNM	MFG. NO. 315286001 315286101	

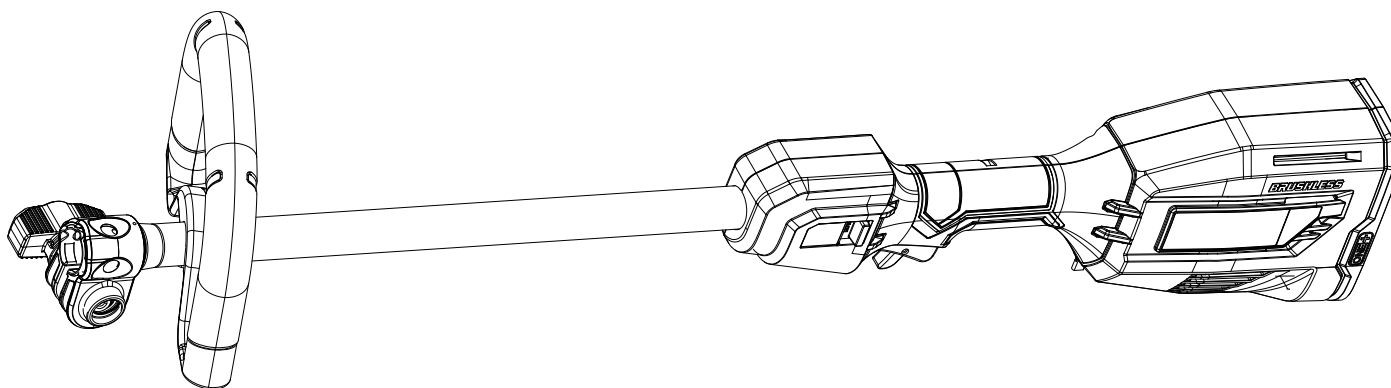

TECHTRONIC INDUSTRIES POWER EQUIPMENT

P.O. Box 1288, Anderson, SC 29622 ■ 1-800-525-2579 ■ www.ryobitools.com

1-11-21 (Rev:04)

The model number and manufacturing location will be found on a label attached to the product. Always mention this information in all communications regarding this product and when ordering parts.

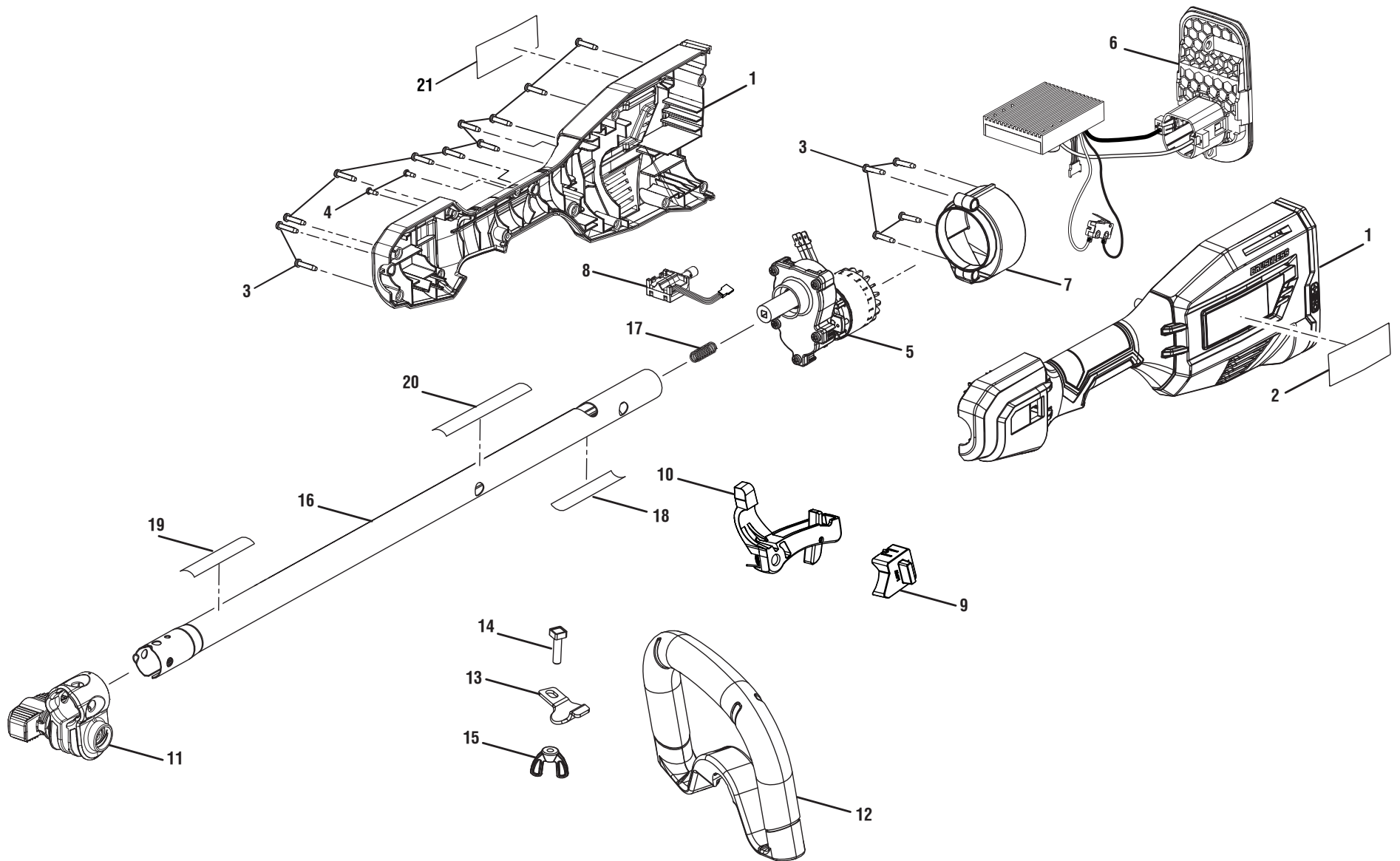



P20104/P20104VNM

PARTS LIST

KEY NO.	PART NO.	DESCRIPTION	QTY.
1	315989001	Rear Handle Assembly (Inc. Key No. 2 & 21)	1
2	940705585	Logo Label	1
3	661864007	Screw (M4 x 18 mm, T15 Torx Pan Hd.)	15
4	660203052	Screw (M3 x 8 mm, Pan Hd.)	2
5	313244003	Motor & Gear Box Assembly	1
6	292194001	Motor Controller & Switch Assembly	1
7	315990001	Motor Volute Assembly	1
8	760649001	Variable Speed Switch	1
9	539255001	Hi-Lo Switch Cover	1
10	314833001	Switch Trigger Assembly	1
11	315386001	Boom Clamp Assembly	1
12	308056009	Front Handle Assembly (Inc. Key Nos. 13-15)	1
13	639167001	Assist Handle Clamp	1

KEY NO.	PART NO.	DESCRIPTION	QTY.
14	660857001	Screw (1/4-20 x 40 mm, Hex Hd.)	1
15	518949001	Wing Nut (1/4-20)	1
16	315991001	Boom Assembly (Inc. Key Nos. 19-22, P20104)	1
	316009001	Boom Assembly (Inc. Key Nos. 19-22, P20104VNM)	1
17	690140011	Compression Spring	1
18	941013005	Warning Label (French/Spanish)	1
19	941851150	Attachment Capable Label	1
20	941588795	Warning Icons Label	1
21	941588484	Data Label (P20104)	1
	941588902	Data Label (P20104VNM)	1
	Not Shown:		
	995000973	Operator's Manual	



P20104/P20104VNM

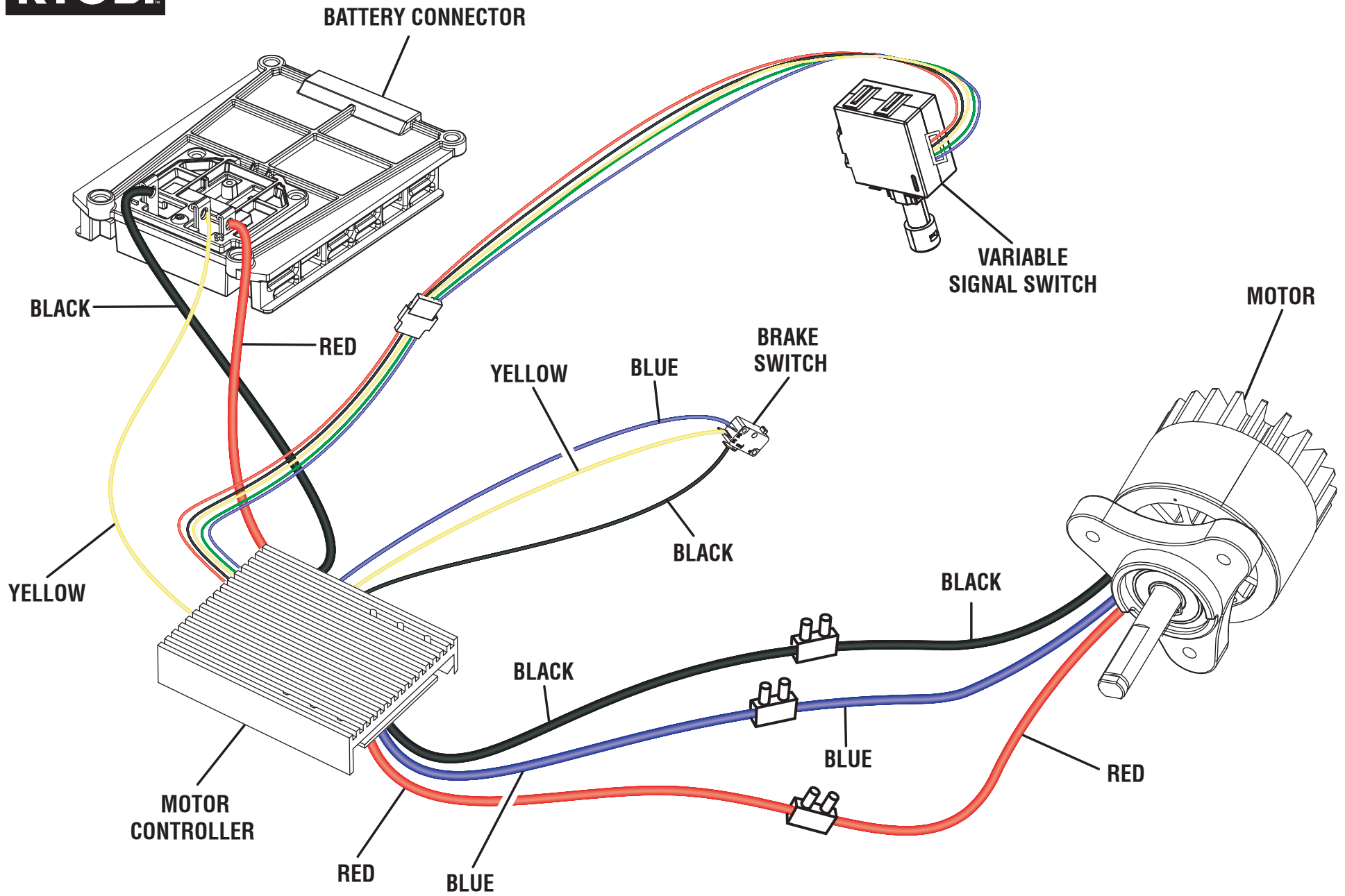

WIRING DIAGRAM

REPAIR SHEET

BRAND RYOBI		DESCRIPTION EXPAND-IT Straight Shaft Trimmer Attachment
MODEL NO. RY15527 RY15527VNM	MFG. NO. 311247006 311247106	

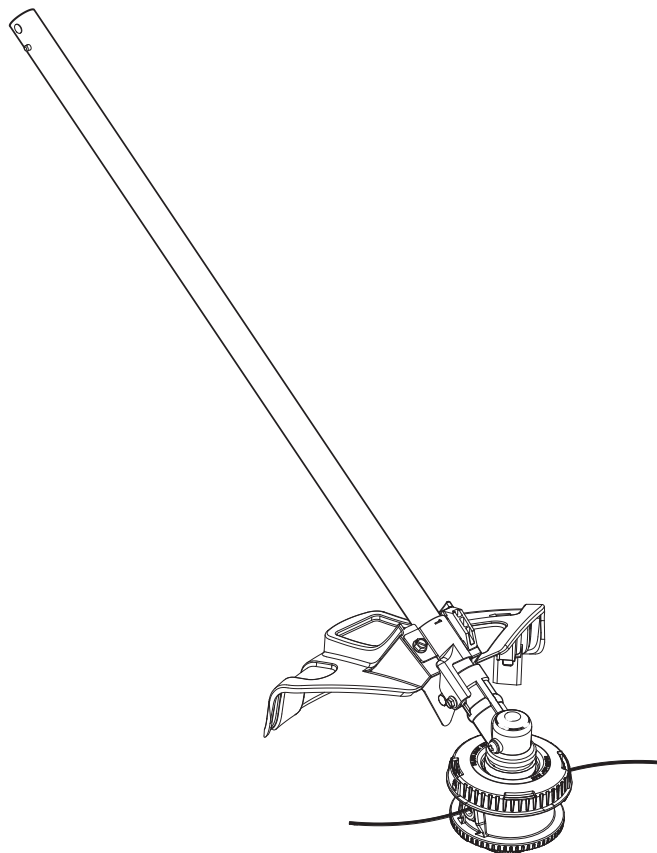

TECHTRONIC INDUSTRIES POWER EQUIPMENT

P.O. Box 1288, Anderson, SC 29622 ■ 1-800-525-2579 ■ www.ryobitools.com

1-11-21 (Rev:06)

The model number and manufacturing location will be found on a label attached to the product. Always mention this information in all communications regarding this product and when ordering parts.

PARTS LIST

KEY NO.	PART NO.	DESCRIPTION	QTY.
1	941588552	Max. Run Time/Performance Label	1
2	315992001	Straight Shaft Assembly (Inc. Key Nos. 3-5, RY15527)	1
	316008001	Straight Shaft Assembly (Inc. Key Nos. 3-5, RY15527VNM)	1
3	940749034	Lower Boom Icon Label	1
4	941851149	Ryobi Expand-it Label	1
5	941588488	Data Label (RY15527)	1
	941588903	Data Label (RY15527VNM)	1
6	660738002	Screw (1/4-20 x 1-1/4 in., Hex Washer Hd.)	1
7	679958001	Compression Spring	1
8	313285005	Grass Deflector Assembly (Inc. Key Nos. 1, 6-7, & 9-10)	1
9	638016003	Line Cut-off Blade	1
10	662148001	Screw (M4.5 mm x 1 mm, Pan Hd.)	2
11	660642001	Screw (1/4-20 x 1-1/4 in., Hex Washer Hd.)	1
12	660641001	Screw (10-24 x 5/8 in., Hex Washer Hd.)	1
13	678011001	Flanged Washer	1
14	308210009	Gear Head	1
15	518367001	Spacer	1
16	638125001	Grass Deflector Clamp	1
17	532048003	Crank Handle	1
18	314608005	Bump Feed Trimmer Head Assembly (Inc. Key No. 19)	1
	Not Shown:		
	995000976	Operator's Manual	

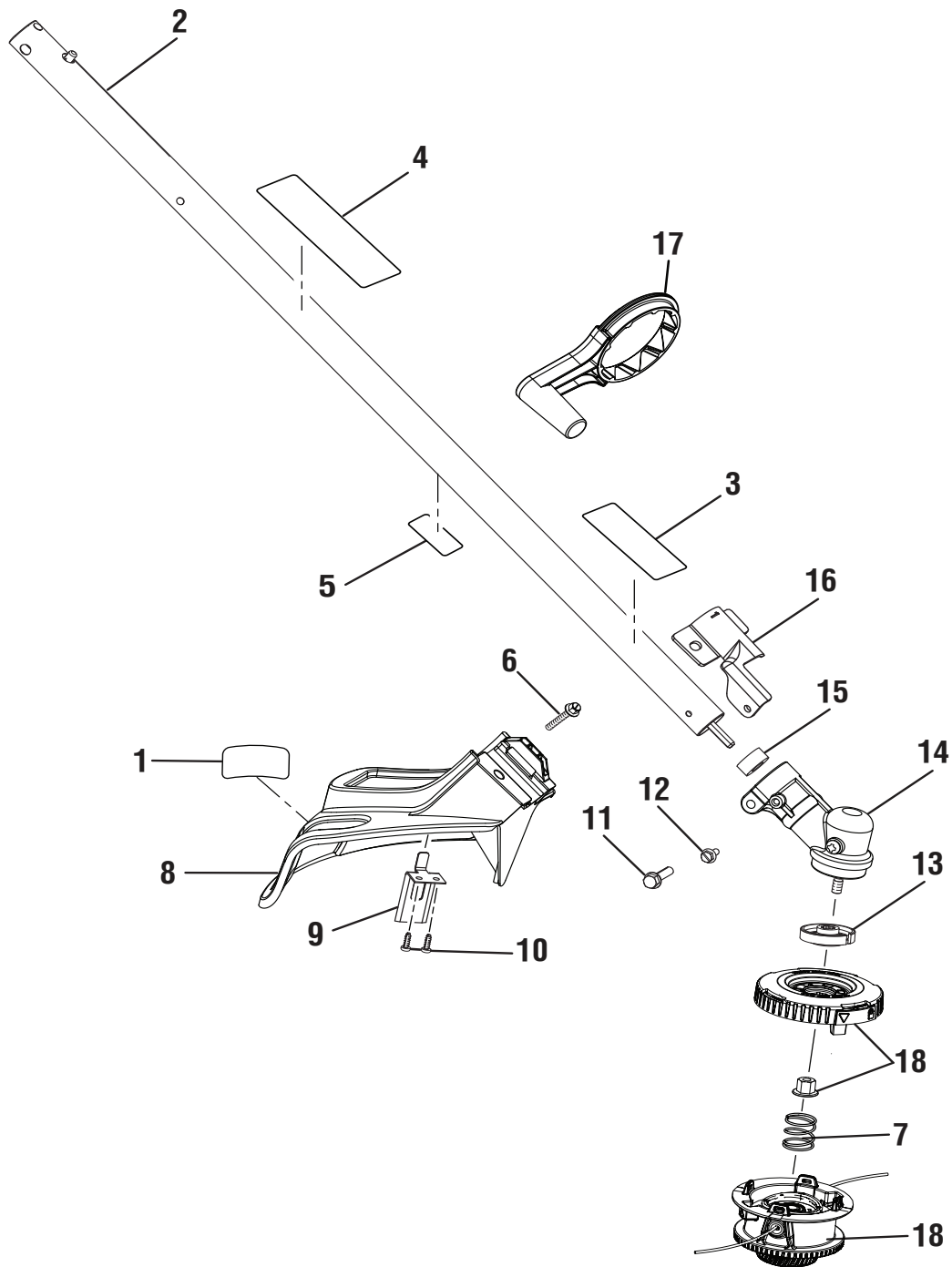

RYOBI EXPAND-IT
Pruner Attachment
Item No. RYPRN33/RYPRN33VNM
Mfg. No. 090112021/095112101
Repair Sheet

TECHTRONIC INDUSTRIES POWER EQUIPMENT
P.O. Box 1288
Anderson, SC 29622 USA
1-800-860-4050

RYOBI EXPAND-IT PRUNER ATTACHMENT - ITEM NO. RYPRN33/RYPN33VNM

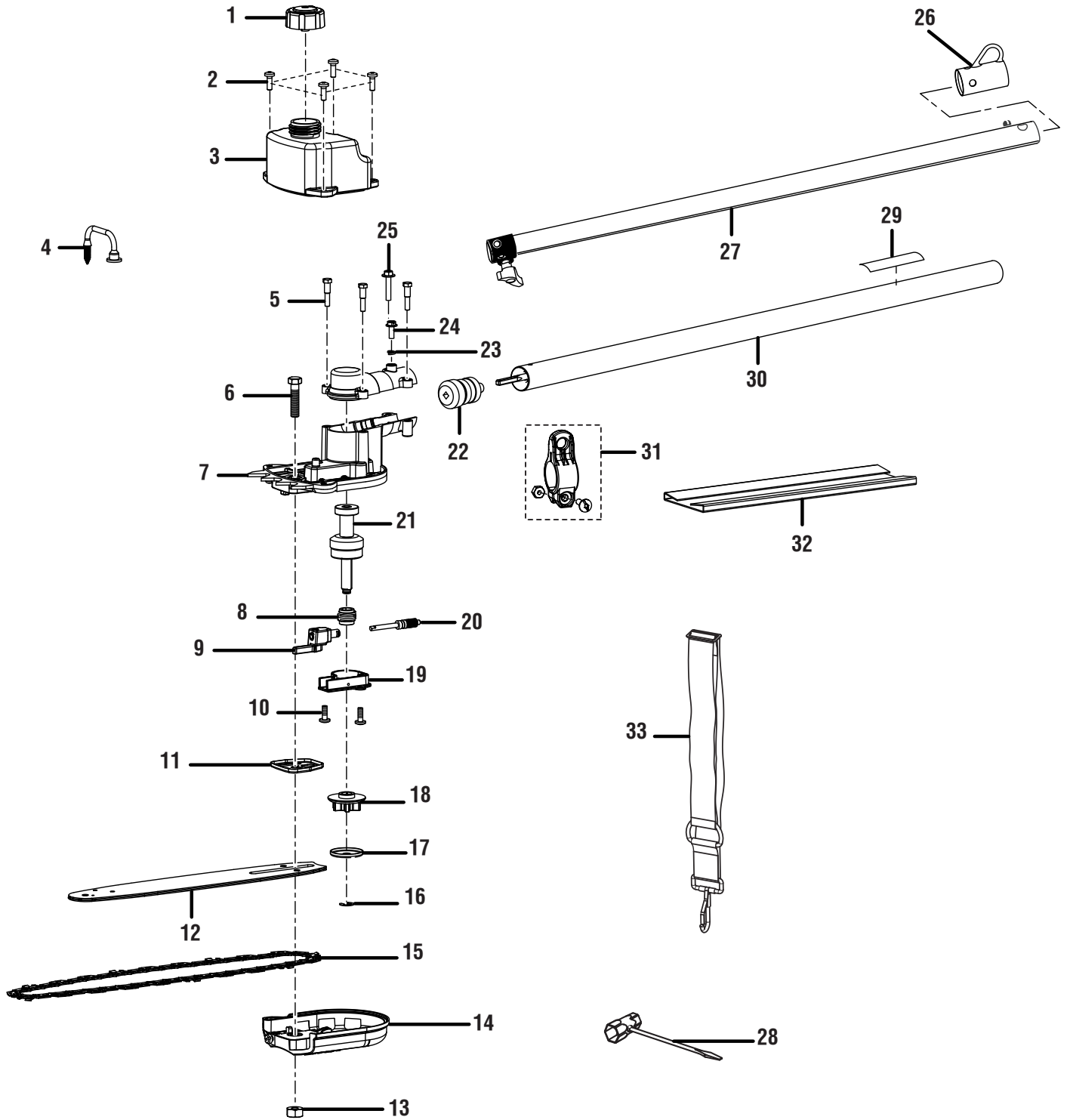

RYOBI EXPAND-IT PRUNER ATTACHMENT – ITEM NO. RYPRN33/RYPN33VNM

The item number and manufacturing number can be found on a label attached to the unit. Always mention the item number and manufacturing number in all correspondence regarding your **PRUNER ATTACHMENT** or when ordering repair parts.

PARTS LIST

KEY NO.	PART NUMBER	DESCRIPTION	QTY
1	308680008	Oil Cap Assembly	1
2	660934003	Screw (M5 x 18 mm)	4
3	580877001	Oil Tank Cover Assembly	1
4	570714001	Oil Pickup Tube	1
5	660913001	Screw (M5 x 25 mm)	3
6	660910002	Screw (M8 x 35 mm)	1
7	308532002	Gear Case Assembly	1
8	610617001	Worm Gear	1
9	308523001	Oil Pump Seal Assembly	1
10	660912001	Screw (M5 x 13 mm)	2
11	638282001	Bar Pad Plate	1
12	671834023	Guide Bar	1
13	678355001	Hex Nut (M8 x 1.25, Special).....	1
14	120530013	Bar Clamp Assembly.....	1
15	693814001	Chain (10 in.).....	1
16	678354001	E-Ring (Ø6 mm).....	1
17	631060001	Cupped Washer.....	1
18	610618001	Sprocket	1
19	308520001	Oil Pump Housing w/Cam Pin Assembly	1
20	308524001	Pinion Gear and Plunger Assembly.....	1
21	308519001	Output Shaft Assembly	1
22	308514001	Pinion and Bearing Assembly	1
23	678284001	Lock Washer (5 mm).....	1
24	660911001	Screw (M5 x 15 mm)	1
25	660935001	Screw (M5 x 25 mm)	1
26	518019002	Hanger Cap	1
27	308010021	Intermediate Boom Assembly (Inc. Key No. 26)	1
28	631055001	Combination Wrench.....	1
29	940657030	Warning Label	1
30	316404001	Lower Drive Shaft Assembly (Inc. Key No. 29) ..	1
31	314811001	Strap Hanger	1
32	518405001	Scabbard.....	1
33	308487001	Shoulder Strap	1

NOT SHOWN:

991000570 Operator's Manual
 3-25-20
 (Rev:02)