

Item # 1005 889 664

Model # HDP00007

HAMPTON BAY[®]

USE AND CARE GUIDE

STRATTON 3 LIGHT SEMI-FLUSH

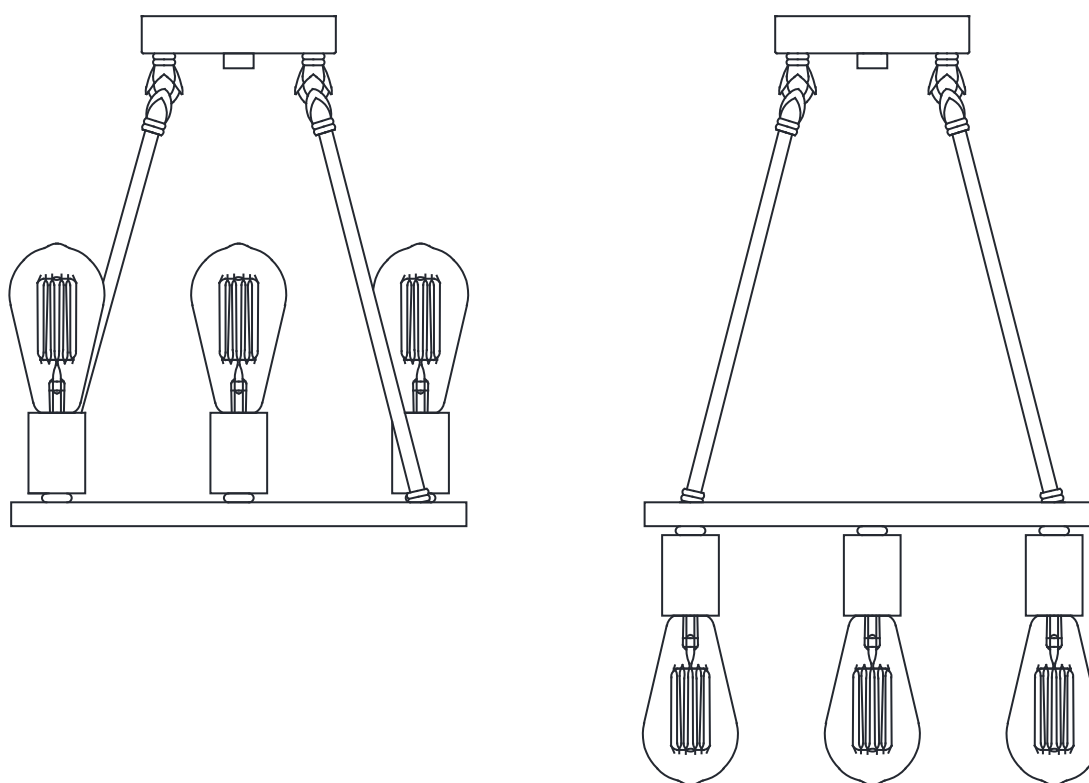

Questions, problems, missing parts? Before returning to the store,
call Hampton Bay Customer Service
8 a.m. – 7 p.m., EST, Monday – Friday, 9 a.m. – 6 p.m., EST, Saturday

1-855-HD-HAMPTON

HAMPTONBAY.COM

THANK YOU

We appreciate the trust and confidence you have placed in Hampton Bay through the purchase of this light fixture. We strive to continually create quality products designed to enhance your home. Visit us online to see our full line of products available for your home improvement needs.

Thank you for choosing Hampton Bay!

Table of Contents

Safety Information	2	Assembly	5
Warranty	2	Installation	5, 6, 7
Pre-Installation	3	Care and Cleaning	7
Planning Installation	3	Troubleshooting	7
Tools Required	3		
Hardware Included	3		
Package Contents	4		

Safety Information

- Consult a qualified electrician with any electrical questions you may have.



IMPORTANT: Inspect the wire insulation for any cuts, abrasions, or exposed copper that may have occurred during shipping. If there is a defect in the wire, do not continue the assembly process. Please call our Customer Service Team at 1-855-HD-HAMPTON.

Warranty

3-YEAR LIMITED WARRANTY

WHAT IS COVERED

The manufacturer warrants this lighting fixture to be free from defects in the materials and workmanship for a period of three (3) years from date of purchase. This warranty applies only to the original consumer purchaser and only to products used in normal use. If this product is found to be defective, the manufacturer's only obligation, and your exclusive remedy, is the repair or replacement of the product at the manufacturer's discretion, provided that the product has not been damaged through misuse, abuse, accident, modifications, alterations, neglect or mishandling. This warranty shall not apply to any product that is found to have been improperly installed, assembled, or used in any way not in accordance with the instructions supplied with the product. This warranty shall not apply to a failure of the product as a result of an accident, misuse, abuse, negligence, alteration, faulty installation, or any other failure not relating to faulty material or workmanship.

WHAT IS NOT COVERED

This warranty shall not apply to the finish on any portion of the product due to weathering, as this is considered normal wear. The manufacturer does not warrant and specifically disclaims any warranty, whether expressed or implied, other than the warranty contained herein. The manufacturer specifically disclaims any liability and shall not be liable for any consequential or incidental loss or damage, including but not limited to, any labor or expense costs involved in the replacement or repair of the product. Contact the Customer Service Team at 1-855-HD-HAMPTON or visit www.HamptonBay.com.

Pre-Installation

PLANNING INSTALLATION

Read all instructions before assembly.

To avoid damaging this product, assemble it on a soft, non-abrasive surface such as carpet or cardboard. Inspect each part for defects that may have occurred during shipping. Keep your receipt and these instructions for proof of purchase.



NOTE: This light fixture requires the use of three 120V, 60Hz, 60-Watt max., medium-base type S21 (ST64) bulbs (included). Do not exceed the recommended wattage.

TOOLS REQUIRED



Safety goggles



Phillips screwdriver

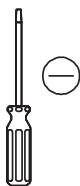

Flathead screwdriver



Pliers



Wire strippers



Wire cutters

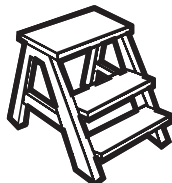

Ladder



Electrical tape

HARDWARE INCLUDED



NOTE: Hardware not shown to actual size.



AA

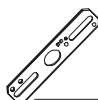

BB



CC



DD



EE



FF



GG

Part	Description	Quantity
AA	Wire nut	3
BB	Cross bar	1
CC	Outlet box screw	2
DD	Lock nut	3
EE	Ground screw	1
FF	Nipple	1
GG	Finial	1

Pre-Installation (continued)

PACKAGE CONTENTS

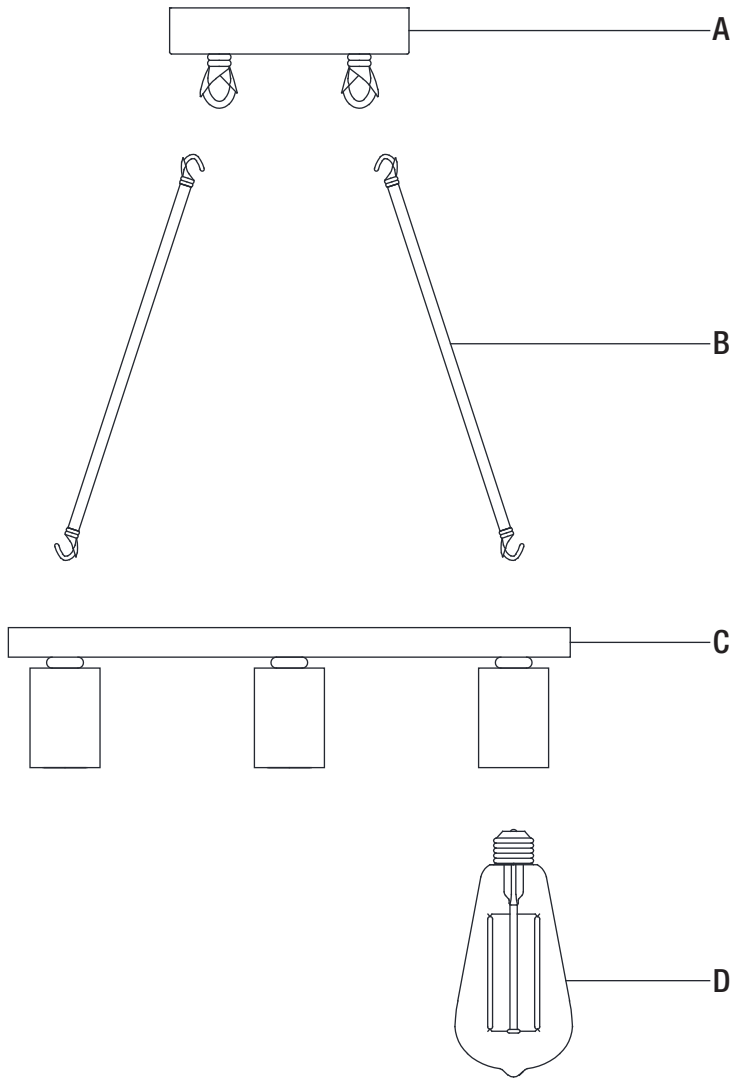

Part	Description	Quantity
A	Column assembly	1
B	Arm	3
C	Fixture body	1
D	Bulb	3

1 Assembling the light fixture

- Carefully unpack the fixture, lay out all parts on clean surface.

This fixture can be assembled up or down.

- Pull the excess cord through the arm (B).
- Pull the excess cord through top of the canopy assembly (A).
- Attach the hooks of arms (B) to the loops of canopy assembly (A).
- Attach the other hooks of arms (B) to the loops of the fixture body (C).

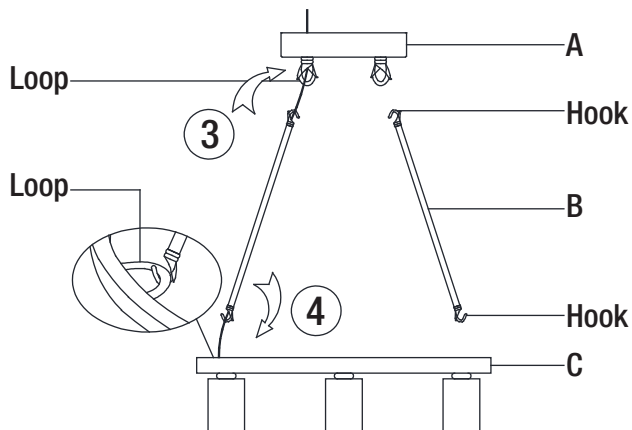
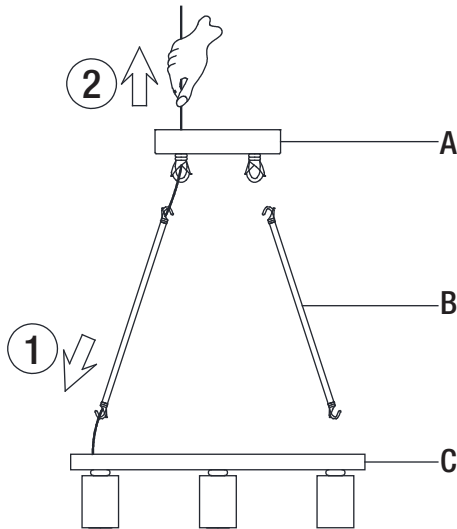

1 Installing the cross bar



DANGER: Ensure the power is off at the main fuse box prior to beginning installation.

- Turn off the switch at the wall.
- Turn the power off at the main fuse box.
- Install the cross bar (BB) with nipple (FF) and lock nuts (DD) to the outlet box using two outlet box screws (CC).

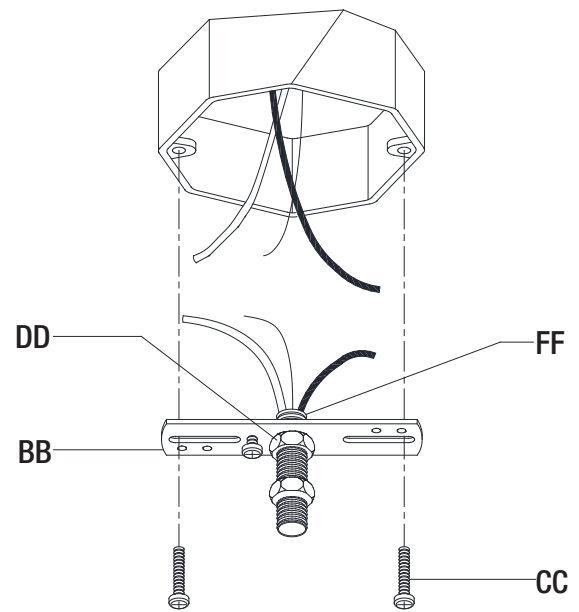

Installation (continued)

2 Connecting the wires

- Install the fixture bare copper ground wire (1) under the ground screw (EE) on the cross bar (BB).
- Connect the fixture bare copper ground wire (1) to the green (or bare, or green & yellow) supply ground wire (2) in the outlet box using a wire nut (AA).
- Connect the ribbed fixture wire (3) to the white supply wire (4) in the outlet box using a wire nut (AA).
- Connect the smooth fixture wire (5) to the black (or red, or blue) supply wire (6) in the outlet box using a wire nut (AA).

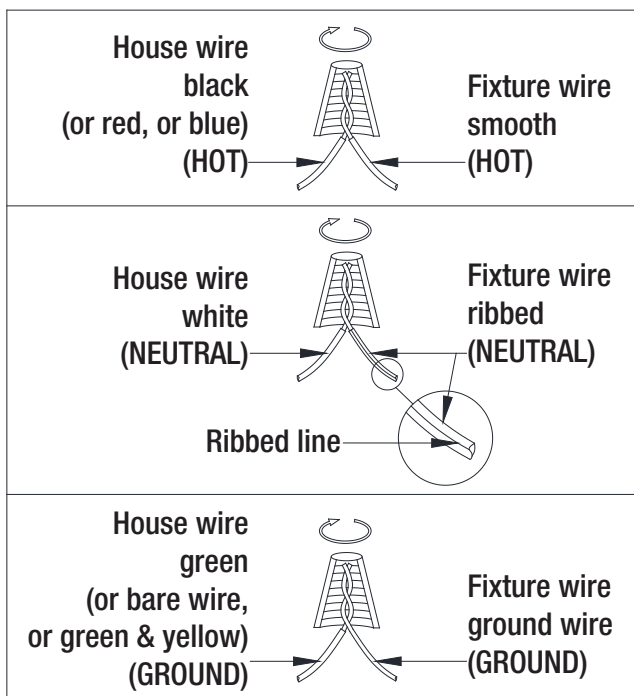
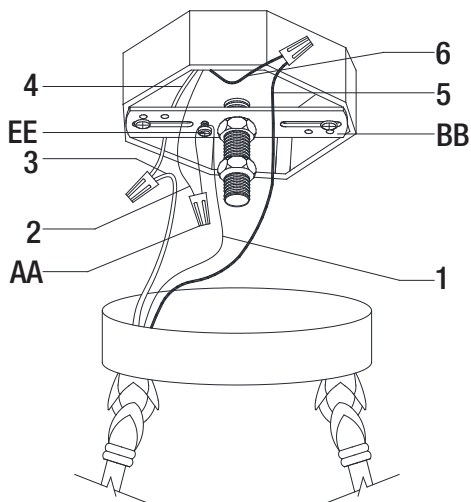

3 Hanging the light fixture

- Push all excess wires into the outlet box.
- Raise the canopy (A) to the ceiling and secure in place by screwing the lock nut (DD) onto the nipple (FF), and then screw the finial (GG) to end of the nipple (FF).

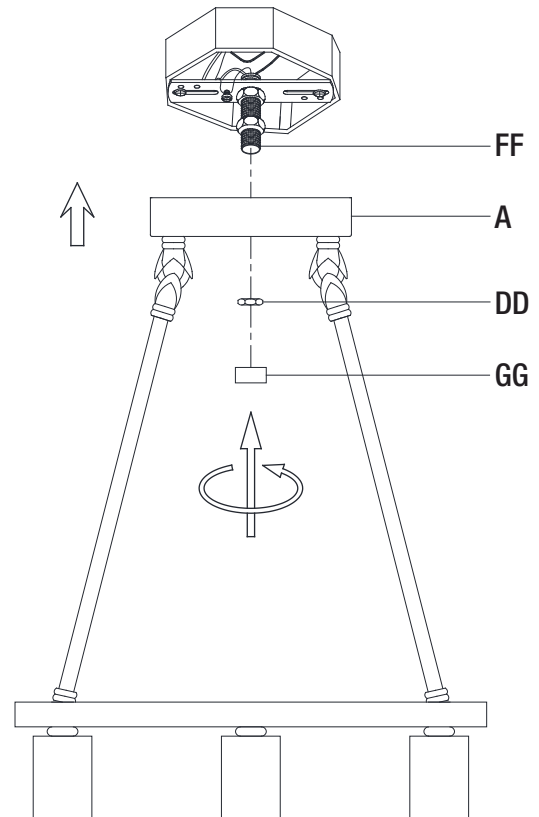

Installation (continued)

4 Assembling the bulbs

- Prior to installing the bulbs, inspect sockets for silica packet. If packet is present, then remove and throw away. Do not expose it to children or pets.
- Install three 120V, 60Hz, 60-Watt medium-base type S21 (ST64) bulbs (D) (included) into the sockets of the light fixture.

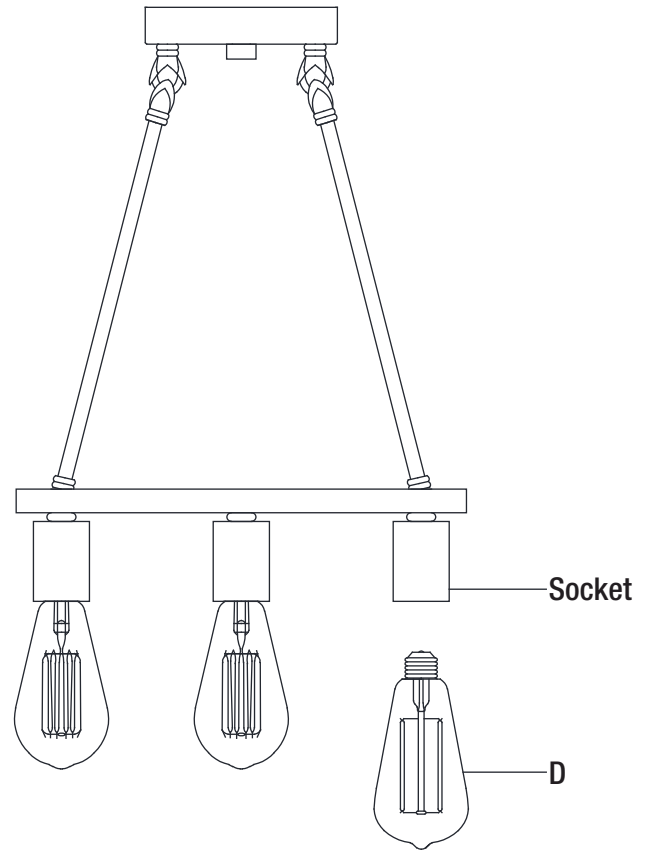

Care and Cleaning

- Clean the light fixture with a soft, dry cloth. Do not use any cleaners with chemicals, solvents, or harsh abrasives.

Troubleshooting

Problem	Possible Cause	Solution
The bulb will not light.	□ The bulb is burned out.	□ Replace the light bulb.
	□ The power is off.	□ Ensure that the power supply is turned on.
	□ There is a faulty wire connection.	□ Check the wiring.
	□ The circuit breaker is off.	□ Ensure that the circuit breaker is set in the on position.
The fuse blows or a circuit breaker trips when the light is turned on.	□ There is an exposed wire.	□ Discontinue use of the light fixture.
	□ There are too many items on one circuit.	□ Contact a qualified electrician or call the Customer Service Team at 1-855-HD-HAMPTON.
		□ Unplug other items on the circuit.

HAMPTON BAY[®]

Questions, problems, missing parts? Before returning to the store,
call Hampton Bay Customer Service
8 a.m. – 7 p.m., EST, Monday – Friday, 9 a.m. – 6 p.m., EST, Saturday

1-855-HD-HAMPTON

HAMPTONBAY.COM

Retain this manual for future use.