

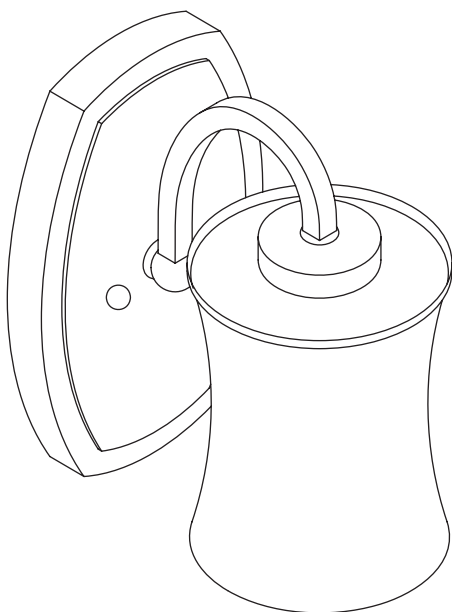

Item #1001 220 089  
Model #19405-HBU

# USE AND CARE GUIDE

## CHAPLINNE WALL SCONCE



Questions, problems, missing parts? Before returning to the store,  
call Hampton Bay Customer Service  
8 a.m. - 7 p.m., EST, Monday - Friday, 9 a.m. - 6 p.m., EST, Saturday

1-855-HD-HAMPTON

HAMPTONBAY.COM

---

### THANK YOU

*We appreciate the trust and confidence you have placed in Hampton Bay through the purchase of this 1-light wall sconce. We strive to continually create quality products designed to enhance your home. Visit us online to see our full line of products available for your home improvement needs. Thank you for choosing Hampton Bay!*

# Table of Contents

Table of Contents.....	2	Hardware Included.....	3
Safety Information.....	2	Package Contents.....	4
Warranty.....	2	Installation.....	5
Pre-Installation.....	3	Care and Cleaning.....	7
Planning Installation .....	3	Troubleshooting.....	7
Tools Required.....	3		

## Safety Information

- Read all instructions before installing.
- Consult a qualified electrician for installation of this fixture.
- If you have any non-electrical questions about this fixture, please contact our Customer Service Team at 1-855-HD-HAMPTON or visit [www.hamptonbay.com](http://www.hamptonbay.com).
- Please reference your SKU 1001 220 089 or (UPC 773546250511)
- Keep your receipt and these instructions for proof of purchase.



**CAUTION:** Before starting installation of this fixture or removal of a previous fixture, disconnect the power by turning off the circuit breaker or by removing the fuse at the fuse box.



**IMPORTANT:** Inspect the wire insulation for any cuts, abrasions, or exposed copper that have occurred during shipping. If there is a defect in the wire, do not continue the installation process. Please call our Customer Service Team at 1-855-HD-HAMPTON.

## Warranty

### LIMITED WARRANTY

#### WHAT IS COVERED

The manufacturer warrants this lighting fixture to be free from defects in materials and workmanship for a period of five (5) years from date of purchase. This warranty applies only to the original consumer purchaser and only to products used in normal use and service. If this product is found to be defective, the manufacturer's only obligation, and your exclusive remedy, is the repair or replacement of the product at the manufacturer's discretion, provided that the product has not been damaged through misuse, abuse, accident, modification, alteration, neglect, or mishandling.

#### WHAT IS NOT COVERED

This warranty shall not apply to any product that is found to have been improperly installed, set-up, or used in any way not in accordance with the instructions supplied with the product. This warranty shall not apply to a failure of the product as a result of an accident, misuse, abuse, negligence, alteration, faulty installation, or any other failure not relating to faulty material or workmanship. This warranty shall not apply to the finish on any portion of the product, such as surface and/or weathering, as this is considered normal wear and tear. The manufacturer does not warrant and specially disclaims any warranty, whether express or implied, of fitness for a particular purpose, other than the warranty contained herein. The manufacturer specifically disclaims any liability and shall not be liable for any consequential or incidental loss or damage, including but not limited to any labor/expense costs involved in the replacement or repair of said product.

Contact Customer Care at 1-855-HD-HAMPTON or visit [www.hamptonbay.com](http://www.hamptonbay.com).

# Pre-Installation

## PLANNING INSTALLATION

Read all instructions before assembly and installation. To avoid damaging this product, assemble it on a soft, non-abrasive surface, such as carpet or cardboard. Inspect each part for defects that may have occurred during shipping. Keep your receipt and these instructions for proof of purchase.

## TOOLS REQUIRED



Safety goggles

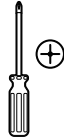

Phillips screwdriver

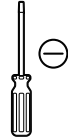

Flathead screwdriver

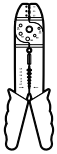

Wire strippers



Wire cutters

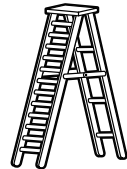

Ladder

## HARDWARE INCLUDED



NOTE: Hardware not shown to actual size.



AA

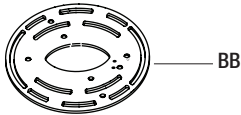

BB

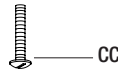

CC



DD



EE

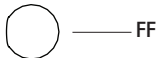

FF



GG

Part	Description	Quantity
AA	Wire nut	3
BB	Mounting plate	1
CC	Outlet box screw	2
DD	Mounting screw	2
EE	Ground screw	1
FF	Ball nut	2
GG	Socket ring	1

# Pre-Installation (continued)

## PACKAGE CONTENTS

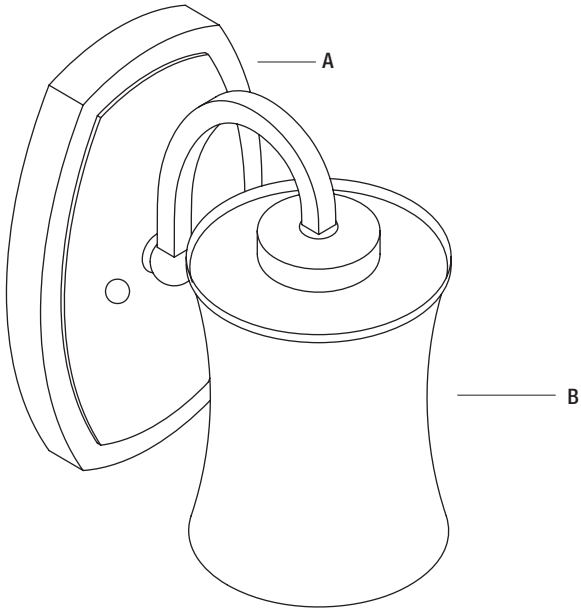

Part	Description	Quantity
A	Fixture body	1
B	Glass shade	1

# Installation

## 1 Detaching the mounting plate

- Disassemble the ball nut (FF) from the mounting screws onto the mounting plate (BB). Remove the mounting plate (BB) from the fixture body (A).

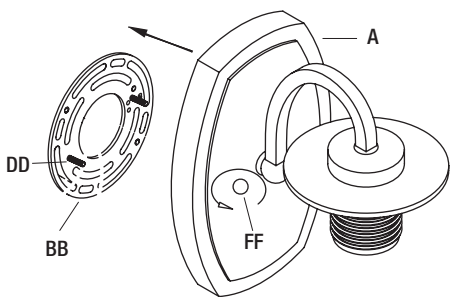

## 3 Making the electrical connections

**NOTE:** Always use wire nuts (AA) or marrettes (included) to connect wires and push all excess wires and connections back into the junction box (not included).

- Fasten the open end of the ground wire (bare copper or green wire) to the ground wire from the junction box or the ground screw (EE) on the mounting plate (BB).
- Connect the black wire of the power supply to the black wire of the fixture and connect the white wire of the power supply to the white wire of the fixture.

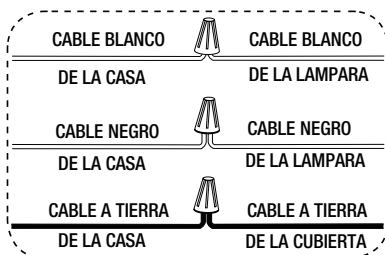

## 2 Installing the mounting plate

**WARNING:** Turn the power off at the main fuse box before installation.

- Secure the mounting plate (BB) onto the outlet box (not included) with the outlet box screws (CC).

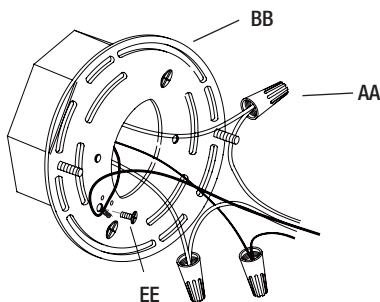
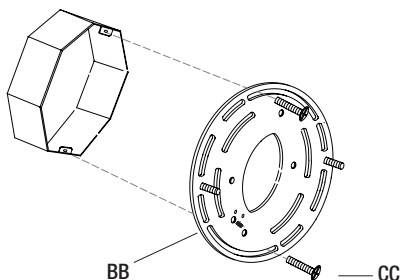

## 4 Installing the fixture body

- Align the mounting holes on the fixture body (A) with the mounting screws (DD) on the mounting plate (BB). Attach the fixture body (A) onto the mounting plate (BB) and secure with the supplied ball nut (FF).

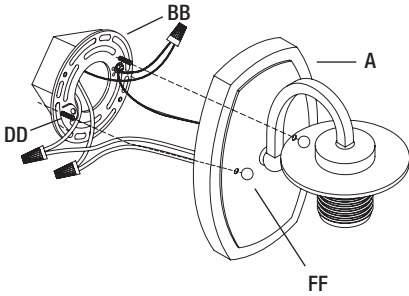

## 6 Installing the bulb

- Install a 60W max. A19 bulb (not included) to the socket of the fixture body.

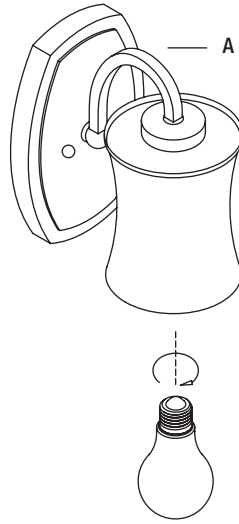

## 5 Installing the glass shade

- Place the glass shade (B) on the socket, secure with the socket ring (GG). Do not overtighten.

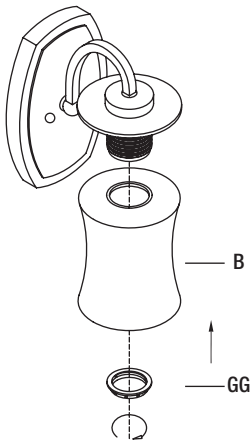

## Care and cleaning

- Clean the light fixture carefully with a soft, dry cloth. Do not use any cleaner with chemicals, solvents, or harsh abrasives.

## Troubleshooting

Problem	Possible Cause	Solution
□ The bulb will not light.	□ The bulb is burned out.	□ Replace the light bulb.
	□ The power is off.	□ Ensure that the power supply is turned on.
	□ The circuit breaker is off.	□ Ensure that the circuit breaker is set to the ON position.
□ The fuse blows or the circuit breaker trips when the light is turned on.	□ There are too many items on one circuit.	□ Unplug the other items on the circuit. □ Contact a qualified electrician or call the Customer Service Team at 1-855-HD-HAMPTON.



Questions, problems, missing parts? Before returning to the store,  
call call Hampton Bay Customer Service  
8 a.m. - 7 p.m., EST, Monday-Friday, 9 a.m. - 6 p.m., EST, Saturday

**1-855-HD-HAMPTON**

**HAMPTONBAY.COM**

Retain this manual for future use.