



SERVICE PARTS LIST

BULLETIN NO.
54-06-2230

SPECIFY CATALOG NO. AND SERIAL NO. WHEN ORDERING PARTS		REVISED BULLETIN	DATE
M12™ ROCKET™ LED TOWER LIGHT			Apr. 2018
CATALOG NO.	2132-20	STARTING SERIAL NO.	J93A
		WIRING INSTRUCTION	

EXAMPLE:
Component Parts (Small #)
Are Included When Ordering
The Assembly (Large #).

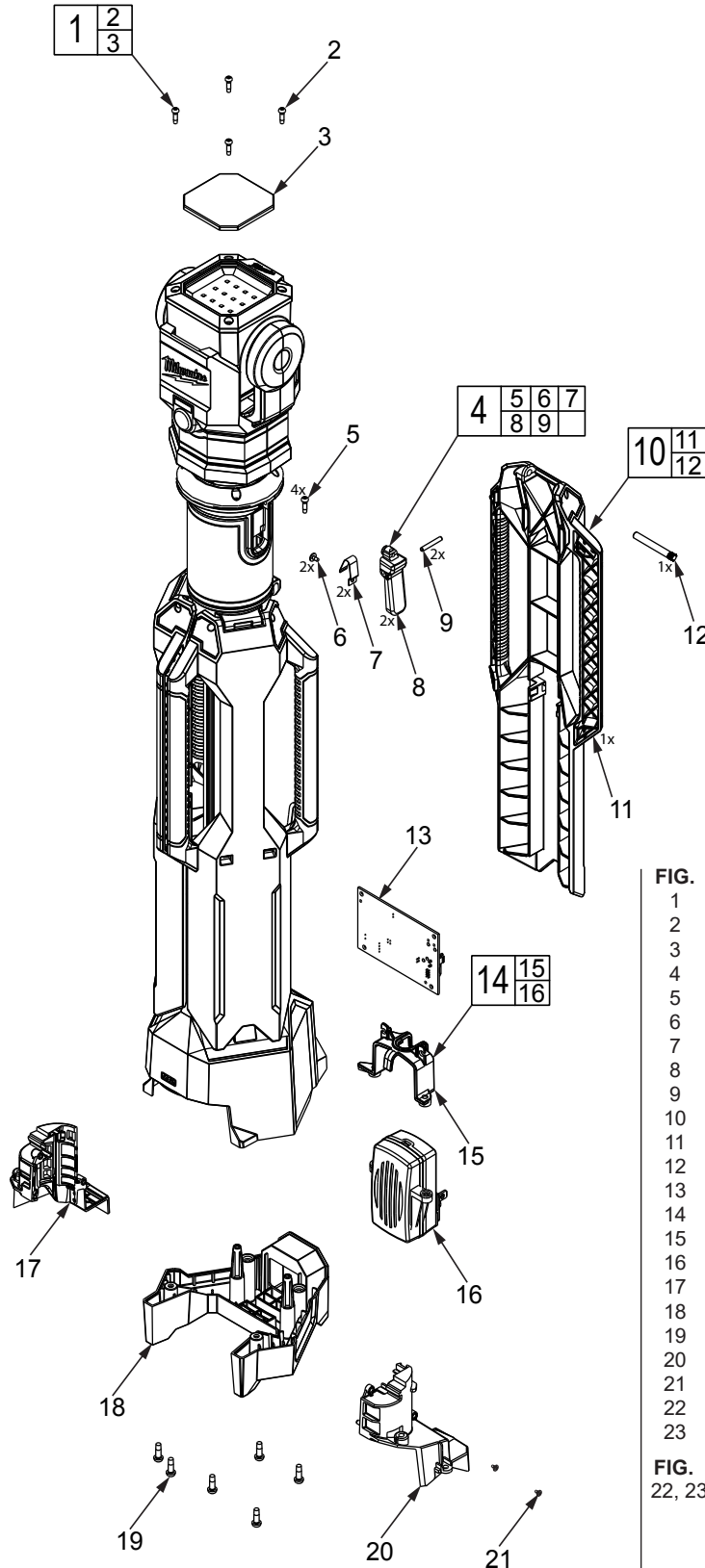

FIG.	PART NO.	DESCRIPTION OF PART	NO. REQ.
1	31-21-0240	Lens Kit	(1)
2	-----	ST Screw M3 x 11	(4)
3	-----	Lens	(1)
4	14-46-0490	Trigger Kit (Set of 2)	(1)
5	-----	ST Screw M3 x 11	(4)
6	-----	ST Screw M2.3 x 5	(2)
7	-----	Trigger Spring Plate	(2)
8	-----	Trigger	(2)
9	-----	Trigger Pin	(2)
10	44-04-0190	Leg Kit (Set of 1)	(3)
11	-----	Leg	(3)
12	-----	Leg Pin	(3)
13	14-20-2132	PCBA Assembly w/ Terminal Block	(1)
14	22-64-2132	Power Adapter Kit	(1)
15	-----	Power Adapter Strap	(1)
16	-----	Power Adapter	(1)
17	31-06-2131	Right Battery Interface	(1)
18	31-06-2130	Bottom Base	(1)
19	06-82-2130	ST Screw M4 x 12	(6)
20	31-06-2132	Left Battery Interface	(1)
21	06-82-2135	ST Screw M3 x 8	(2)
22	12-20-2133	Service Nameplate (Not Shown)	(1)
23	10-20-2092	Warning Label (Not Shown)	(1)

FIG. NOTES
22, 23 A clean, dry surface is essential for proper performance for any adhesive system. The area intended for application of any adhesive label or nameplate must be prepared by cleaning with isopropyl alcohol. The solvent is to be applied with a clean, lint free applicator and the surface allowed to dry before applying the label or nameplate.