

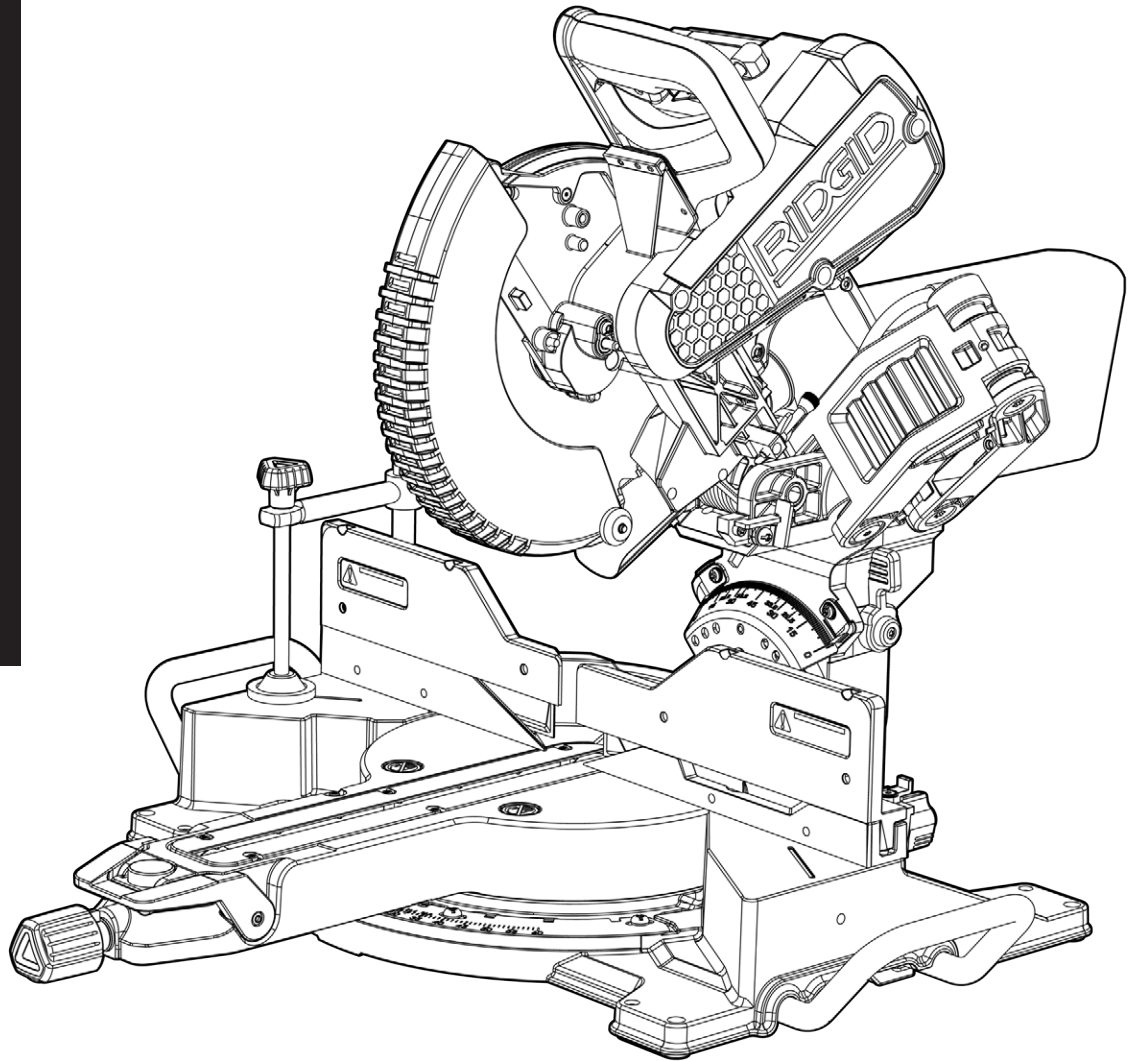

OPERATOR'S MANUAL

10 inch Sliding Compound Miter Saw

R4241



Your saw has been engineered and manufactured to our high standard for dependability, ease of operation, and operator safety. When properly cared for, it will give you years of rugged, trouble-free performance.



WARNING:

To reduce the risk of injury, the user must read and understand the operator's manual before using this product.

SAVE THIS MANUAL FOR FUTURE REFERENCE

TABLE OF CONTENTS

FEATURES	2	MITER LOCK ADJUSTMENT	18
PRODUCT SPECIFICATIONS	2	THROAT PLATE	19
KNOW YOUR COMPOUND MITER SAW	5	MOUNTING AND TRANSPORTATION	20
IMPORTANT SAFETY INSTRUCTIONS	6	PREPARATIONS FOR TRANSPORTATION	20
SAFETY LOGOS	6	MOUNTING SAW TO STABLE SURFACE	21
GENERAL POWER TOOL SAFETY WARNINGS	7	INSTALLING WORKPIECE SUPPORT EXTENSIONS	21
SAFETY INSTRUCTIONS FOR MITER SAWS	8	OPERATION	22
PROPOSITION 65 WARNING	9	CUTTING WARPED MATERIAL	22
POWER CONNECTIONS	10	CLAMPING WIDE WORKPIECES	23
DOUBLE INSULATION	10	SUPPORTING LONG WORKPIECES	23
ELECTRICAL CONNECTION	10	POWER SWITCH LOCK	24
POLARIZED PLUGS	10	SHADOW LINE	24
EXTENSION CORDS	10	NON-SLIDING CUTS	25
UNPACKING	11	FOR MITER CUTS	25
REMOVING CONTENTS FROM PACKING	11	FOR BEVEL CUTS	26
PACKAGED CONTENTS LIST	11	FOR COMPOUND MITER CUTS	26
ASSEMBLY	12	SLIDE CUTS	28
TOOLS NEEDED	12	TIPS FOR CUTTING CROWN MOLDING	29
WORK CLAMP	13	AUXILIARY FENCE	30
DUST BAG	13	EXPAND WORKTABLE AREA	31
DUST PORT ATTACHMENT	13	MAINTENANCE	32
INSTALL/REMOVE THE BLADE	14	KEEP MACHINE CLEAN	32
ADJUSTMENTS	15	GENERAL MAINTENANCE	32
ALIGN THE BLADE TO TABLE	15	BRUSH REPLACEMENT	32
ALIGN THE BLADE TO FENCE	16	LUBRICATION	32
DEPTH STOP ADJUSTMENT	17	TROUBLE SHOOTING	33
FENCE EXTENSION	17	FAILURE TO START	33
BEVEL LOCK TENSION ADJUSTMENT	17	ACCESSORIES	33
SLIDE RESISTANCE	18	PARTS, SERVICES OR WARRANTY ASSISTANCE	34

NOTE: The manual cover illustrates the current production model. All other illustrations contained in the manual are representative only and may not be exact depictions of the actual labeling or accessories included. They are intended for illustrative purposes only.

FEATURES

PRODUCT SPECIFICATIONS

Cutting Capacity (Maximum nominal lumber sizes)	0° Miter/0° Bevel: 4 inch x 12 inch (2 x16 inch) Extended Capacity 45° Miter/ 0° Bevel: 4 inch x 8 inch 0° Miter/45° Bevel: 2 inch x 12 inch (Right 45° Bevel:1 inch x 12 inch) 45° Miter/45° Bevel: 2 inch x 8 inch (Right 45° Bevel:1 inch x 8 inch)
Baseboard (Vertical)	5.5 inch
Crown (Vertically Nested)	6.5 inch
Net Weight	55 lbs
Input	120 V~, 60hz, 15 Amps
Blade Arbor Hole	5/8 inch
Blade Diameter	10 inch
No Load Speed	4,000 r/min (RPM)
Blade Max Speed Rating	6,000 r/min (RPM)
Number of Teeth	40
Blade Thickness	0.07 inch (1.8 mm)
Blade Kerf	0.1 inch (2.6mm)

BLADE DESCRIPTIONS		
APPLICATION	DIAMETER	TEETH
Construction Saw Blades (thin kerf with anti-stick rim)		
General Purpose	10 inch (254mm)	40
Fine Crosscuts	10 inch (254mm)	60
Woodworking Saw Blades (provide smooth, clean cuts)		
Fine crosscuts	10 inch (254mm)	80

NOTE: ONLY use blades that are marked for speeds of 4,000 r/min (RPM) or higher. **NEVER** use a smaller diameter blade. It will not be guarded properly. Use crosscut blades only. **DO NOT** use blades designed for ripping, combination blades or blades with hook angles in excess of 7°.

FEATURES

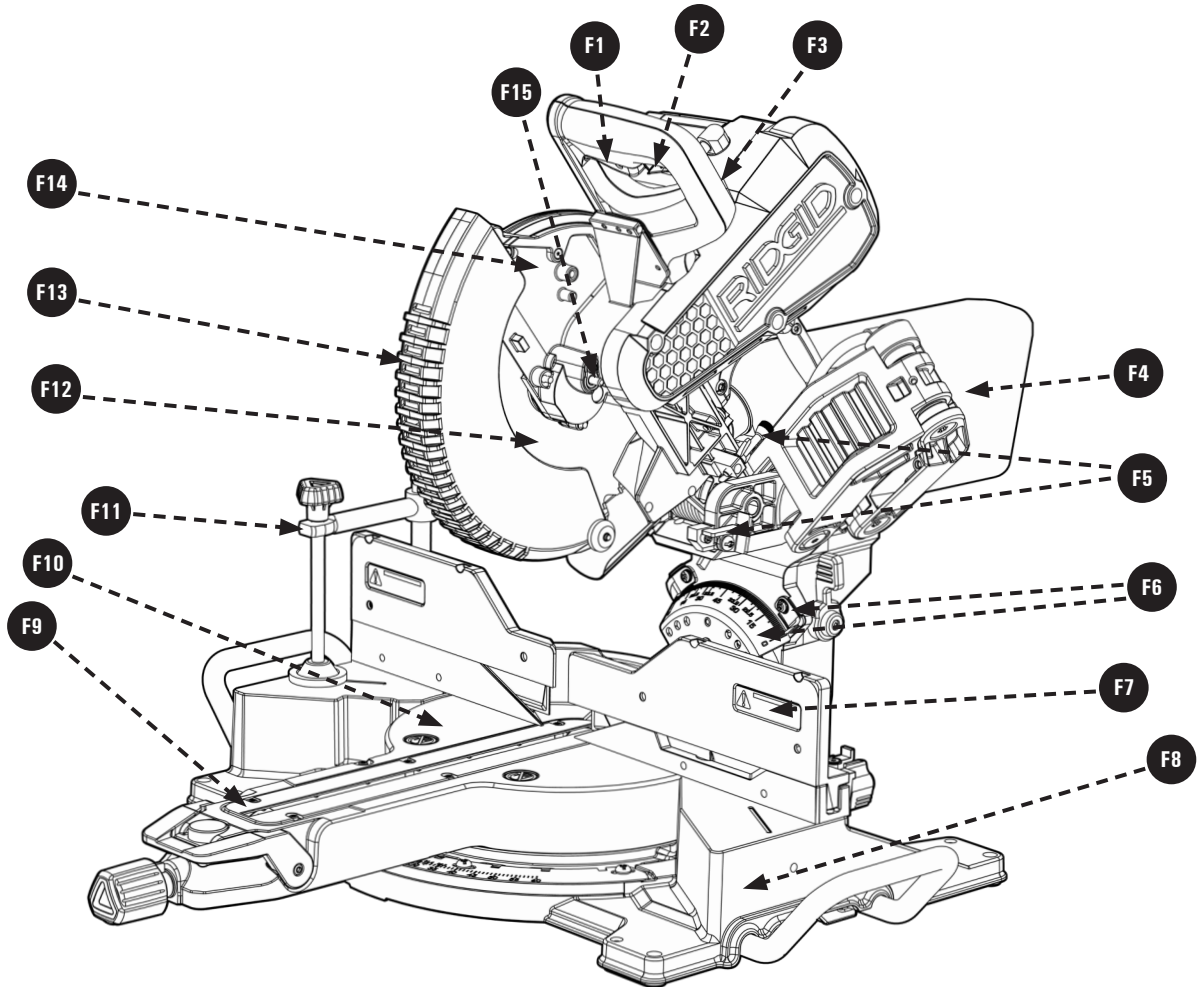
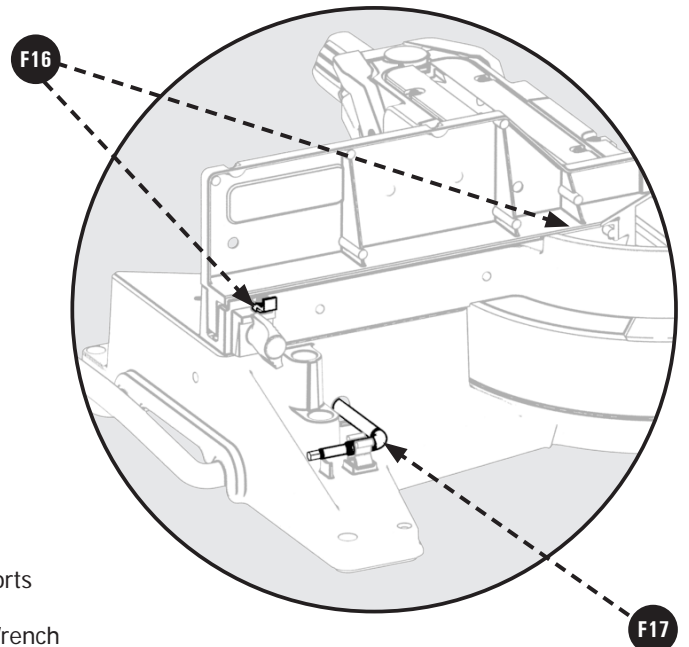

Figure 1

- | | |
|---|----------------------------------|
| F1 On/Off Switch and Lockout Hole | F10 Work Table |
| F2 Safety Switch | F11 Clamp |
| F3 Shadow Guide ON/OFF Switch | F12 Blade |
| F4 Dust Bag | F13 Lower Guard |
| F5 Depth Stop Screw/Depth Stop Plate | F14 Upper Guard |
| F6 Bevel Scale and Indicator | F15 Spindle Lock |
| F7 Sliding Fence | F16 Back Fence Supports |
| F8 Base | F17 T30 Torx/Blade Wrench |
| F9 Throat Plate | |



FEATURES

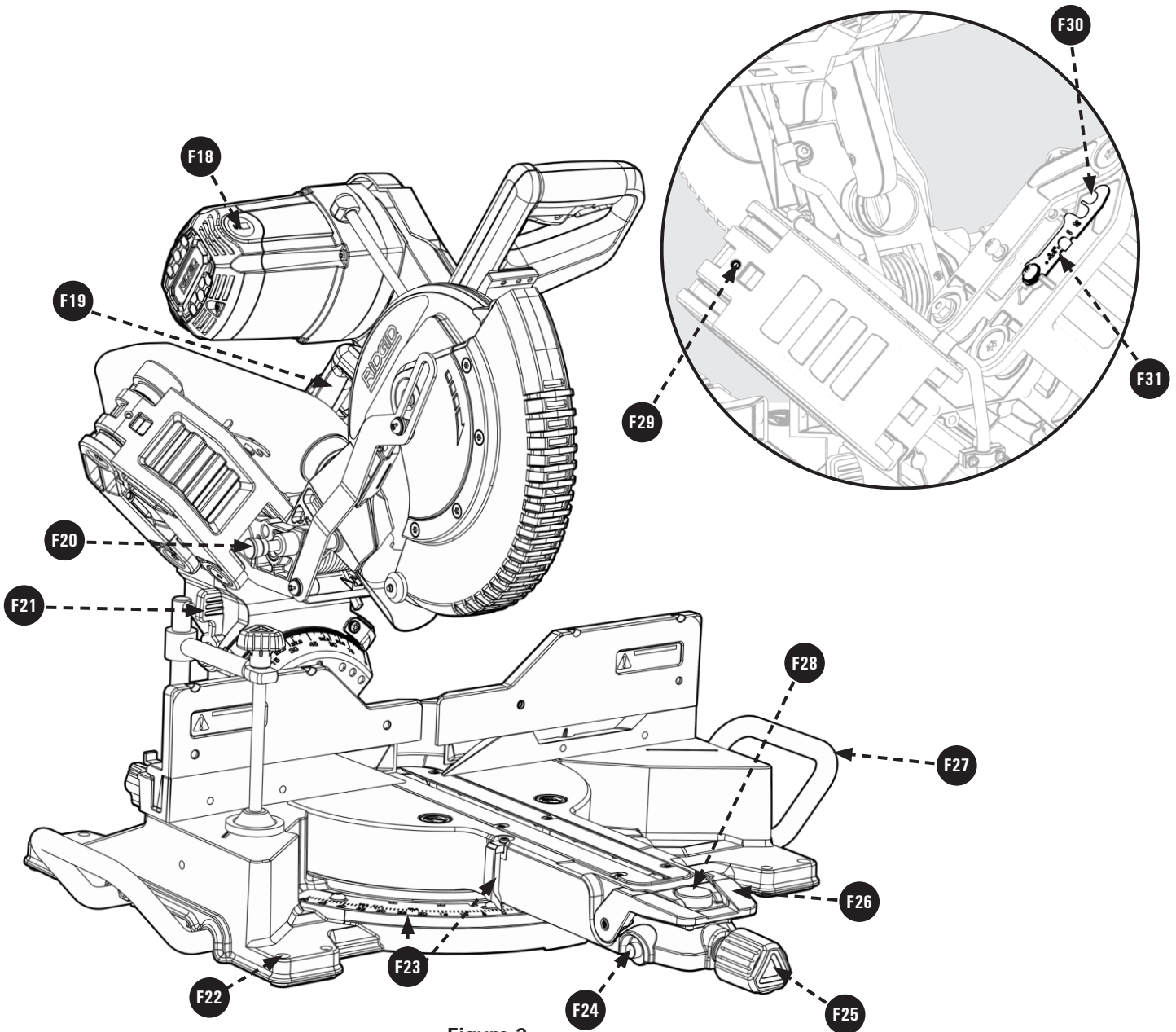

Figure 2

- | | |
|---|--|
| F18 Brush Caps | F25 Miter Lock Knob |
| F19 Carrying Handle | F26 Bevel Lock/Unlock Handle |
| F20 Head Lock Pin | F27 Support Extension (2) |
| F21 Bevel Detent Latch (2) | F28 Miter Detent Lock/Unlock Button |
| F22 Mounting Holes (4) | F29 Glide Adjustment |
| F23 Miter Scale and Indicator | F30 Baseboard Position Notch |
| F24 Miter Detent Override Button | F31 Slide Lock |

FEATURES

KNOW YOUR COMPOUND MITER SAW

- 1. On/Off Switch and Lockout Hole:** This saw is activated by an easy to use, hand operated, power on/off switch. When not in use the saw should be disconnected from the power supply and locked using a padlock inserted through the lockout hole located on the power on/off switch.
- 2. Safety Switch:** This switch helps prevent accidental start, must be engaged along with power switch to operate machine.
- 3. Shadow Guide ON/OFF Switch:** This switch turns on the shadow line guide feature.
- 4. Dust Bag:** The dust bag collects and contains the saw dust during the cutting operations.
- 5. Depth Stop Screw/Depth Stop Plate:** The screw/depth stop plate can be used to make a non-through cut. The screw/depth stop screw allows the depth of cut to be adjusted.
- 6. Bevel Scale and Indicator:** These indicate the current blade bevel position and are adjustable; This allows for fine calibration of the blade alignment.
- 7. Sliding Fence:** The fence supports the workpiece when making all cuts. The sliding fences are adjustable.
- 8. Base:** Supports the tool and features mounting holes.
- 9. Throat Plate (Kerf Plate):** The throat plate supports the workpiece from underneath, on both sides of the blade, to minimize workpiece tear out.
- 10. Work Table:** The die-cast aluminum work table provides a level and sturdy work surface.
- 11. Clamp:** The vertical work clamp helps to position and secure the workpiece to the work table. This provides for safer operation and more accurate cuts.
- 12. Blade:** A 10 inch blade is included with the compound miter saw.
- 13. Lower Guard:** The lower blade guard is made of shock-resistant, see-through plastic that provides protection from the blade.
- 14. Upper Guard:** Cast aluminum protects user from blade.
- 15. Spindle Lock:** Engage the spindle lock when changing the blade in order to hold the blade into position while you loosen the blade bolt.
- 16. Back Fence Supports:** These provide workpiece support and additional cut capacity when the sliding fences are removed.
- 17. T30 Torx/Blade Wrench:** This wrench features a L key Torx head with an Allen Wrench and should be used when removing, installing, or changing the blade.
- 18. Brush Caps:** This provides access to your saw's motor's carbon brushes, in the event they need to be inspected or replaced.
- 19. Carrying Handle:** Use this to transport your saw. Make sure the Slide and Head lock are engaged before transporting.
- 20. Head Lock Pin:** This allows the saw head to be locked into the full down position, for transportation.
- 21. Bevel Detent Latch (2):** This latch engages/disengages the bevel detent pin which allows the bevel angle to be locked into one of the detent positions.
- 22. Mounting Holes (x4):** Enables you to securely mount the tool to a stable surface.
- 23. Miter Scale and Indicator:** These indicate the current blade miter position and are adjustable; This allows for fine calibration of the blade alignment.
- 24. Miter Detent Override Button:** This button holds the miter detent into the unlocked position which allows free movement of the miter arm without holding the miter detent lock/unlock button.
- 25. Miter Lock Knob:** This knob locks the blade miter angle securely into place. Always lock before making any cuts.
- 26. Bevel Lock/Unlock Handle:** This handle locks the blade bevel angle securely into place. Always lock before making any cuts.
- 27. Support Extension (2):** These act as table extensions to help support longer work pieces.
- 28. Miter Detent Lock/Unlock Button:** This button allows you to release the miter arm from the positive stops and freely rotate the miter arm/work table.
- 29. Glide Adjustment:** This adjust the friction for the front to back, saw head siding movement.
- 30. Baseboard Position Notch:** This notch, when engaged, allows this saw to operate like a chop saw. This eliminates the sliding ability, but still allows the blade to clear the fence during operation.
- 31. Slide Lock:** This allows the saw head to be locked into the fully retracted position, for transportation.
- 32. E-Brake (Not Shown):** This brake will slow your blade down quickly when the power switch is disengaged (release hand from power switch).

IMPORTANT SAFETY INSTRUCTIONS

⚠ WARNING: CAREFULLY READ AND FOLLOW ALL WARNINGS AND INSTRUCTIONS ON YOUR PRODUCT AND IN THIS MANUAL. SAVE THIS MANUAL. MAKE SURE ALL USERS ARE FAMILIAR WITH ITS WARNINGS AND INSTRUCTIONS WHEN USING THE TOOL. Improper operation, maintenance or modification of tools or equipment could result in serious injury and/or property damage.



SAFETY LOGOS

This manual contains information that is important for you to know and understand. This information relates to protecting YOUR SAFETY and PREVENTING EQUIPMENT PROBLEMS. To help you recognize this information, we use the symbols below. Please read the manual and pay attention to these sections.

⚠ DANGER: Indicates an imminently hazardous situation which, if not avoided, will result in death or serious injury.

⚠ WARNING: Indicates a potentially hazardous situation which, if not avoided, could result in death or serious injury.

⚠ CAUTION: Indicates a potentially hazardous situation which, if not avoided, may result in minor or moderate injury.

CAUTION: Used without the safety alert symbol indicates potentially hazardous situation which, if not avoided, may result in property damage.

Additional information regarding the safe and proper operation of this tool is available from the following sources:

- Power Tool Institute, 1300 Sumner Avenue, Cleveland, OH 44115-2851 or on-line at www.powertoolinstitute.com
- National Safety Council, 1121 Spring Lake Drive, Itasca, IL 60143-3201
- American National Standards Institute, 25 West 43rd Street, 4 floor, New York, NY 10036 www.ansi.org - ANSI 01.1 Safety Requirements for Woodworking Machines
- U.S. Department of Labor regulations www.osha.gov

Some of the following symbols may be used on the tool. Please study them and learn their meaning. Proper interpretation on these symbols will allow you to operate the tool better and safer.

SYMBOL	NAME	DESIGNATION/EXPLANATION
	Safety Alert	Indicates a potential personal injury hazard.
	Read Operator's Manual	To reduce the risk of injury, user must read and understand operator's manual before using this product.
	Eye Protection	Always wear eye protection with side shields marked to comply with ANSI Z87.1.
	No Hands Symbol	Failure to keep your hands away from the blade will result in serious personal injury.
	Wet Conditions Alert	Do not expose to rain or use in damp locations.
	Pinch Warning	Always watch for movement paying extra attention to potential areas where pinching could occur.
V	Volts	Voltage
A	Amperes	Current
Hz	Hertz	Frequency (cycles per second)
min	Minutes	Time
~/AC	Alternating Current	Type of current
n ₀	No Load Speed	Rotational speed, at no load
.../min	Per Minute	Revolutions, strokes, surface speed, orbits, etc., per minute
Lbs	Pounds	Unit of weight
Kg	Kilograms	Unit of weight
RPM	Revolutions Per Minute	Speed of rotation of machine
PH:1	Phase 1	This is a 1 phase motor
	Double Insulation	To reduce the risk of electric shock, this equipment has a polarized plug (one blade is wider than the other). This plug will fit in a polarized outlet only one way. If the plug does not fit fully in the outlet, reverse the plug. If it still does not fit, contact a qualified electrician to install the proper outlet. DO NOT change the plug in any way.

GENERAL POWER TOOL SAFETY WARNINGS

⚠ WARNING: Read all safety warnings, instructions, illustrations and specifications provided with this power tool. Failure to follow all instructions listed below may result in electric shock, fire and/or serious injury.

Save all warnings and instructions for future reference.

The term “power tool” in the warnings refers to your mains-operated (corded) power tool or BATTERY-operated (cordless) power tool.

1. Work area safety

- a. **Keep work area clean and well lit.** Cluttered or dark areas invite accidents.
- b. **Do not operate power tools in explosive atmospheres, such as in the presence of flammable liquids, gases or dust.** Power tools create sparks which may ignite the dust or fumes.
- c. **Keep children and bystanders away while operating a power tool.** Distractions can cause you to lose control.

2. Electrical safety



- a. **Power tool plugs must match the outlet. Never modify the plug in any way. Do not use any adapter with earthed (grounded) power tools.** Unmodified plugs and matching outlets will reduce risk of electric shock
- b. **Avoid body contact with earthed or grounded surfaces, such as pipes, radiators, ranges and refrigerators.** There is an increased risk of electric shock if your body is earthed or grounded.
- c. **Do not expose power tools to rain or wet conditions.** Water entering a power tool will increase the risk of electric shock.
- d. **Do not abuse the cord. Never use the cord for carrying, pulling or unplugging the power tool. Keep cord away from heat oil, sharp edges or moving parts.** Damaged or entangled cords increase the risk of electric shock.
- e. **When operating a power tool outdoors, use an extension cord suitable for outdoor use.** Use of a cord suitable for outdoor use reduces the risk of electric shock.
- f. **If operating a power tool in a damp location is unavoidable, use a ground fault circuit interrupter (GFCI) protected supply.** Use of an GFCI reduces the risk of electric shock.

3. Personal safety

- a. **Stay alert, watch what you are doing and use common sense when operating a power tool. Do not use a power tool while you are tired or under the influence of drugs, alcohol or medication.** A moment of inattention while operating power tools may result in serious personal injury.
- b. **Use personal protective equipment. Always wear eye protection.** Protective equipment such as dust mask, non-skid safety shoes, hard hat, or hearing protection used for appropriate conditions will reduce personal injuries.
- c. **Prevent unintentional starting. Ensure the switch is in the off-position before connection to power source, picking up, or carrying the tool.** Carrying power tools with your finger on the switch or energising power tools that have the switch on invites accidents.
- d. **Remove any adjusting key or wrench before turning the power tool on.** A wrench or a key left attached to a rotating part of the power tool may result in personal injury.
- e. **Do not overreach. Keep proper footing and balance at all times.** This enables better control of the power tool in unexpected situations.
- f. **Dress properly. Do not wear loose clothing or jewelry. Keep your hair, clothing and gloves away from moving parts.** Loose clothes, jewelry or long hair can be caught in moving parts.
- g. **If devices are provided for the connection of dust extraction and collection facilities, ensure these are connected and properly used.** Use of dust collection can reduce dust-related hazards.
- h. **Do not let familiarity gained from frequent use of tools allow you to become complacent and ignore tool safety principles.** A careless action can cause severe injury within a fraction of a second.

4. Power tool use and care

- a. **Do not force the power tool. Use the correct power tool for you application.** The correct power tool will do the job better and safer at the rate for which it was designed.
- b. **Do not use the power tool if the switch does not turn it on and off.** Any power tool that cannot be controlled with the switch is dangerous and must be repaired.
- c. **Disconnect the plug from the power source before making any adjustments, changing accessories, or storing power tools.** Such preventive safety measures reduce the risk of starting the power tool accidentally.
- d. **Store idle power tools out of the reach of children and do not allow persons unfamiliar with the power tool or these instructions to operate the power tool.** Power tools are dangerous in the hands of untrained users.
- e. **Maintain power tools and accessories. Check for misalignment or binding of moving parts, breakage of parts and any other condition that may affect the power tool's operation. If damaged, have the power tool repaired before use.** Many accidents are caused by poorly maintained power tools.

GENERAL POWER TOOL SAFETY WARNINGS

- f. **Keep cutting tools sharp and clean.** Properly maintained cutting tools with sharp cutting edges are less likely to bind and are easier to control.
- g. **Use the power tool, accessories and tools bits etc. in accordance with these instructions, taking into account the working conditions and the work to be performed.** Use of the power tool for operations different from those intended could result in a hazardous situation.
- h. **Keep Handles and grasping surfaces dry, clean and free from oil and grease.** Slippery handles and grasping surfaces do not allow for safe handling and control of the tool in unexpected situations.

5. Service

- a. **Have your power tool serviced by a qualified repair person using only identical replacement parts.** This will ensure that the safety of the power tool is maintained.

SAFETY INSTRUCTIONS FOR MITER SAWS

1.
 - a. **Miter saws are intended to cut wood or wood-like products, they cannot be used with abrasive cut-off wheels for cutting ferrous material such as bars, rods, studs, etc.** Abrasive dust causes moving parts such as the lower guard to jam. Sparks from abrasive cutting will burn the lower guard, the kerf insert and other plastic parts.
 - b. **Use clamps to support the workpiece whenever possible. If supporting the workplace by hand, you must always keep your hand at least 100mm from either side of the saw blade. Do not use this saw to cut pieces that are too small to be securely clamped or held by hand.** If your hand is placed too close to the saw blade, there is an increased risk of injury from blade contact.
 - c. **The workpiece must be stationary and clamped or held against both the fence and the table. Do not feed the workpiece into the blade or cut "freehand" in any way.** Unrestrained or moving workpieces could be thrown at high speeds, causing injury.
 - d. **Push the saw through the workpiece. Do not pull the saw through the workpiece. To make a cut, raise the saw head and pull it out over the workpiece without cutting, start the motor, press the saw head down and push the saw through the workpiece.** Cutting on the pull stroke is likely to cause the saw blade to climb on top of the workpiece and violently throw the blade assembly towards the operator.
 - e. **Never cross your hand over the intended line of cutting either in front or behind the saw blade.** Supporting the workpiece "cross handed" i.e. holding the workpiece to the right of the saw blade with your left hand or vice versa is very dangerous.
 - f. **Do not reach behind the fence with either hand closer than 100mm from either side of the saw blade, to remove wood scraps, or for any other reason while the blade is spinning.** The proximity of the spinning saw blade to your hand may not be obvious and you may be seriously injured.
 - g. **Inspect your workpiece before cutting. If the workpiece is bowed or warped, clamp it with the outside bowed face toward the fence. Always make certain that there is no gap between the workpiece, fence and table along the line of the cut.** Bent or warped workpieces can twist or shift and may cause binding on the spinning saw blade while cutting. There should be no nails or foreign objects in the workpiece.
 - h. **Do not use the saw until the table is clear of all tools, wood scraps, etc., except for the workpiece.** Small debris or loose pieces of wood or other objects that contact the revolving blade can be thrown with high speed.
 - i. **Cut only one workpiece at a time.** Stacked multiple workpieces cannot be adequately clamped or braced and may bind on the blade or shift during cutting.
 - j. **Ensure the miter saw is mounted or placed on a level, firm work surface before use.** A level and firm work surface reduces the risk of the miter saw becoming unstable.
 - k. **Plan your work. Every time you change the bevel or miter angle setting, make sure the adjustable fence is set correctly to support the workpiece and will not interface with the blade or the guarding system.** Without turning the tool "ON" and with no workpiece on the table, move the saw blade through a complete simulated cut to assure there will be no interference or danger of cutting the fence.
 - l. **Provide adequate support such as table extensions, saw horses, etc. for a workpiece that is wider or longer than the table top.** Workpieces longer or wider than the miter saw table can if not securely supported. If the cut-off piece or workpiece tips, it can lift the lower guard or be thrown by the spinning blade.
 - m. **Do not use another person as a substitute for a table extension or as additional support.** Unstable support for the workpiece can cause the blade to bind or the workpiece to shift during the cutting operation pulling you and the helper into the spinning blade.
 - n. **The cut-off piece must not be jammed or pressed by any means against the spinning saw blade.** If confined, i.e. using length stops, the cut-off piece could get wedged the blade and thrown violently.
 - o. **Always use a clamp or a fixture designed to properly support round material such as rods or tubing.** Rods have a tendency to roll while being cut, causing the blade to "bite" and pull the work with your hand into the blade.
 - p. **Let the blade reach full speed before contacting the workpiece.** This will reduce the risk of the workpiece

SAFETY INSTRUCTIONS FOR MITER SAWS

- being thrown.
- q. **If the workpiece or blade becomes jammed, turn the miter saw off. Wait for all moving parts to stop and disconnect the plug from the power source and/or remove the battery pack. Then work to free the jammed material.** Continued sawing with a jammed workpiece could cause loss of control or damage to the miter saw.
 - r. **After finishing the cut, release switch, hold the saw down and wait for the blade to stop before removing the cut-off piece.** Reaching with your hand near the coasting blade is dangerous.
 - s. **Hold the handle, firmly when making an incomplete cut or when releasing the switch before the saw head is completely in the position.** The breaking action of the saw may cause the saw to be suddenly pulled downward, causing a risk of injury.
 - t. **Saw Head lock pin is for storage and transport only.** This saw should never be locked in the down position while making cuts.
 - u. **Do not** operate saw without guards in place.

PROPOSITION 65 WARNING:

▲ WARNING: Dust created by power sanding, sawing, grinding, drilling, and other construction activities may contain chemicals known to the state of California to cause cancer, birth defects or other reproductive harm. Some examples are:

- Lead from lead-based paints
- Crystalline silica from bricks and cement and other masonry products
- Asbestos dust
- Arsenic and chromium from chemically-treated lumber

Your risk from these exposures varies depending on how often you do this type of work. To reduce your exposure to these chemicals: work in a well-ventilated area and work with approved safety equipment, such as dust masks that are specifically designed to filter out microscopic particles.

Avoid prolonged contact with dust from power sanding, sawing, grinding, drilling, and other construction activities. Wear protective clothing and wash exposed areas with soap and water.

SAVE THESE INSTRUCTIONS.

Refer to them often and use them to instruct others.

If tool is loaned to someone, also loan them these instructions.

POWER CONNECTIONS

A separate electrical circuit should be used for your machines. This circuit should not be less than #12 wire. Before connecting the machine to the power line make sure the switch(es) is(are) in the "OFF" position and be sure that the electric current is of the same characteristics as indicated on the machine. All line connections should make good contact. Running on low voltage will damage the machine.

⚠ DANGER: DO NOT EXPOSE THE MACHINE TO RAIN OR OPERATE THE MACHINE IN DAMP LOCATIONS.

Your machine is wired for 120 volts, 60 HZ alternating current. Before connecting the machine to the power source, make sure the switch is in the "OFF" position.

DOUBLE INSULATION

This machine is double insulated. Double insulation is a concept in safety in electric power tools, which eliminates the need for the usual three-wire grounded power cord. All exposed metal parts are isolated from the internal metal motor components with protecting insulation. Double insulated tools do not need to be grounded.

⚠ WARNING: The double insulated system is designed to protect the user from shock resulting from a break in the tool's internal insulation. However, it is important to observe normal safety precautions to avoid electrical shock.

NOTE: Servicing of a tool with double insulation requires extreme care and knowledge of the system and should be performed by a qualified service technician. For service, we suggest you return the tool to the nearest authorized service center for repair. **ALWAYS** use identical replacement parts when servicing.

ELECTRICAL CONNECTION

This tool has a precision-built electric motor. It should be connected to a POWER SUPPLY THAT IS 120 VOLTS, 60 HZ, AC **ONLY** (NORMAL HOUSEHOLD CURRENT). **DO NOT** operate this tool on direct current (DC). A substantial voltage drop will cause a loss of power and the motor will overheat. If the tool does not operate when plugged into an outlet, double-check the power supply.

POLARIZED PLUGS

To reduce the risk of electric shock, this equipment has a polarized plug (one blade is wider than the other). This plug will fit in a polarized outlet only one way. If the plug does not fully fit in the outlet reverse the plug. If it still does not fit, contact a qualified electrician to install the proper outlet. **DO NOT** change the plug in any way.

EXTENSION CORDS

When using a power tool at a considerable distance from a power source, be sure to use an extension cord that has the capacity to handle the current the tool will draw. An undersized cord will cause a drop in line voltage, resulting in overheating and loss of power. Use the chart to determine the minimum wire size required in an extension cord. **ONLY** round jacketed cords listed by Underwriter's Laboratories (UL) should be used.

NOTE: Before using any extension cord, inspect it for loose or exposed wires and cut or worn insulation.

⚠ WARNING: **KEEP** the extension cord clear of the work area. Position the cord so that it will not get caught on lumber, tools or other obstructions while you are working with a power tool. Failure to do so can result in serious personal injury. Check extension cords before each use. If damaged replace immediately. **NEVER** use tool with a damaged cord, since touching the damaged area could cause electrical shock resulting in serious injury.

** Ampere rating (on total data label)	
12A- 16A	
Cord Length	Wire Size
25'	14 AWG
50'	12 AWG
** Used on 12 gauge - 20 amp circuit	
NOTE: AWG = American Wire Gauge	

UNPACKING

REMOVING CONTENTS FROM PACKAGING

⚠ WARNING: Check shipping carton and machine for damage before unpacking. Carefully remove packaging materials, parts and machine from shipping carton. **ALWAYS** check for and remove protective shipping materials around motor and moving parts. Lay out all parts on a clean work surface.

- Compare package contents to Component Parts List and Hardware Package List prior to assembly to make sure all items are present. Carefully inspect parts to make sure no damage occurred during shipping. If any parts are missing, damaged or pre-assembled, **DO NOT** assemble. Instead, call RIDGID® Customer Service at (toll free) 1-888-359-4778.
- If any parts are missing, **DO NOT** attempt to plug in the power cord and turn the power on. The saw should **ONLY** be energized after all parts have been located and correctly assembled.
- This saw is packaged and shipped with saw head secured in the down position. Please see preparing “Your Saw for Transport” section of this manual for instructions on how to use the saw head lock pin. Once the saw head is in the upright position, remove styrofoam packaging block and discard.

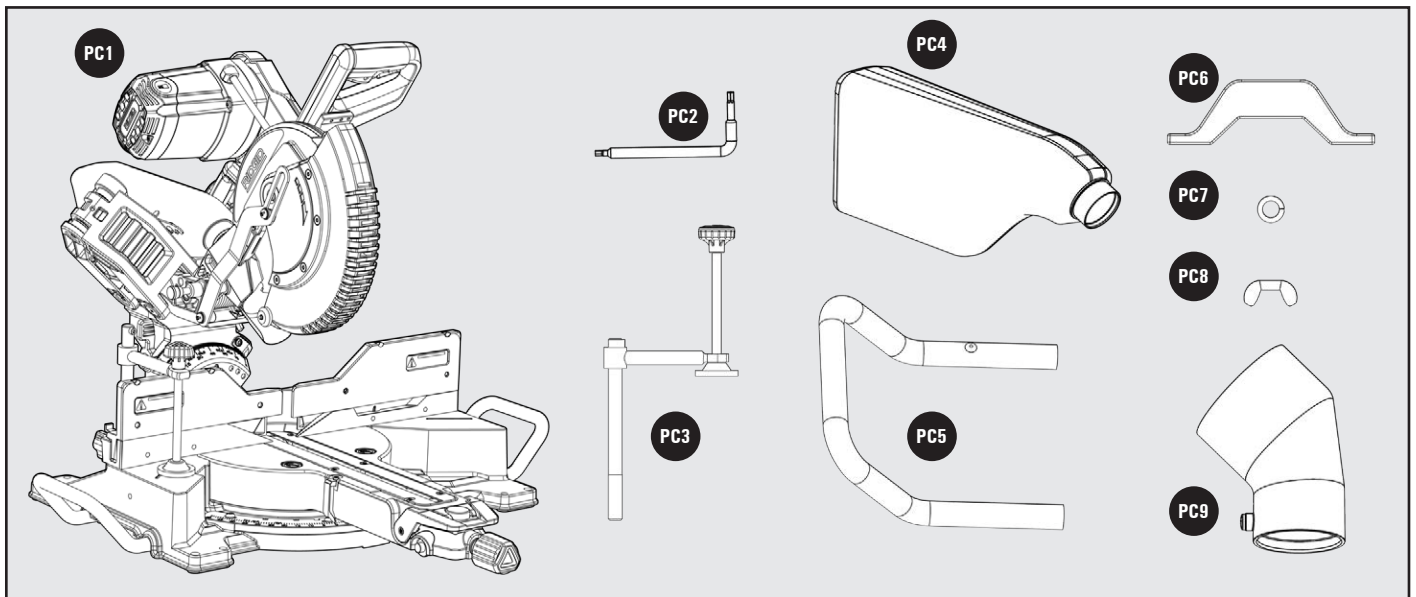

Figure 3

PACKAGED CONTENTS LIST

- | | |
|---|---|
| PC1 RIDGID® R4241 | PC5 Support Extension (2) |
| PC2 T30 Torx/Blade Wrench
(on machine) *see Figure 1 for storage location | PC6 Extension Clamp (2) |
| PC3 Work Clamp | PC7 Washer (2) |
| PC4 Dust Bag | PC8 Wing Nut (2) |
| | PC9 2 1/2 inch Dust Port Adapter |

ASSEMBLY

TOOLS NEEDED

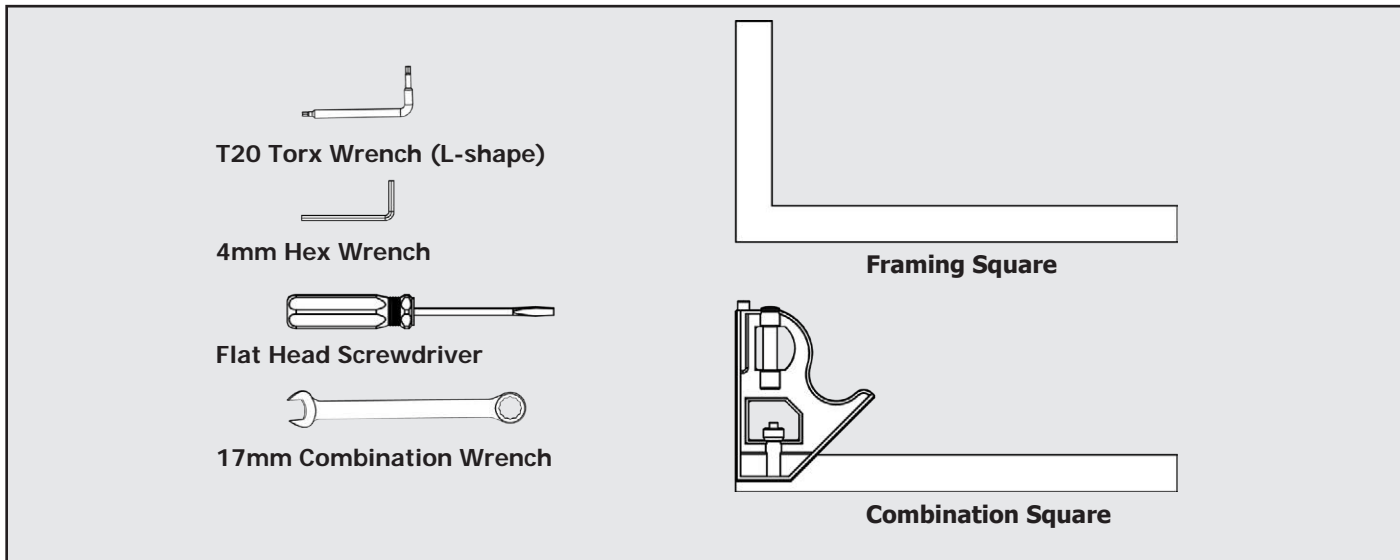

Figure 4

⚠ WARNING:

- **DO NOT** attempt to modify this Tool or create accessories not recommended for use with this Tool. Any such alteration or modification is misuse and could result in a hazardous condition.
- **DO NOT** connect to power supply until assembly is complete. Failure to comply could result in accidental starting.
- **DO NOT** start the Miter Saw without checking for interference between the Blade and the Miter Fence. Damage could result to the Blade if it strikes the Miter Fence during operation of the Saw.
- The Saw can tip over if the Saw Head is released suddenly and the Saw is not secured to a work surface. **ALWAYS** secure this Saw to a stable work surface before any use.
- If any parts are damaged or missing **DO NOT** operate this tool until the parts are replaced. Please call RIDGID® Customer Service at (toll free) 1-888-359-4778.

ASSEMBLY

WORK CLAMP

See Figure 5

The Vertical Work Clamp secures the workpiece to the table to provide more stability and keeps the workpiece from creeping toward the saw blade.

To install the Vertical Work Clamp do the following:

1. Place the Clamp Shaft (A) in either hole (B) on the Miter Base.
2. Slide the clamp arm so the pad touches the workpiece.
3. Rotate the knob (C) clockwise to secure the workpiece. To loosen, turn Counter Clock Wise.

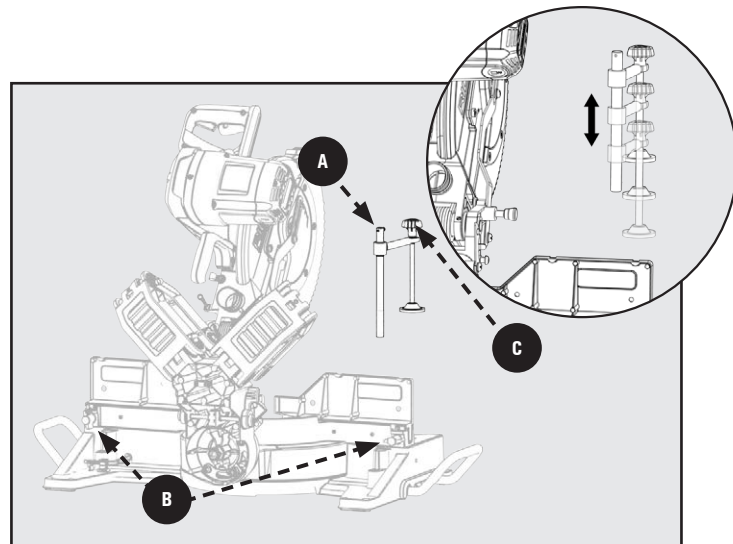

Figure 5

DUST BAG

See Figure 6.

The Tool includes a Dust Bag (PC4) that attaches over the Exhaust Port on the Upper Blade Guard. Slide the Plastic Collar onto the Dust Exhaust Port on the back of the Saw Head.

NOTE: To remove the Dust Bag for emptying, simply reverse the above procedure.

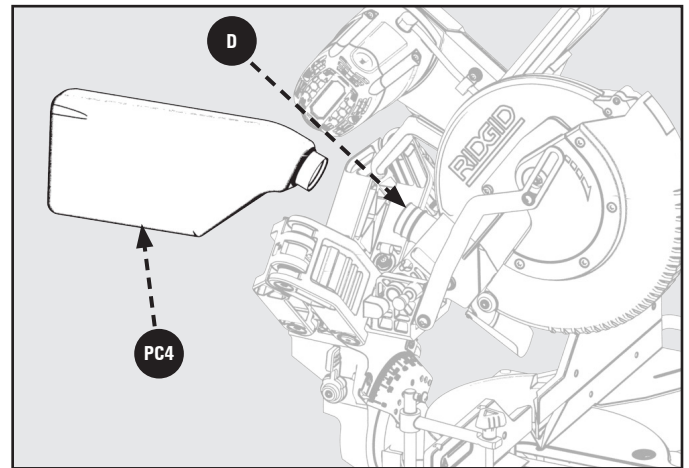

Figure 6

DUST PORT ATTACHMENT

See Figure 7.

The tool includes a 2 1/2 inch Dust Port Adapter (PC9) that attaches over the rear exhaust port on the Upper Blade Guard. It can be used to connect your miter saw to a standard 2 1/2 inch vacuum or dust collection hose.

1. The dust port adapter set-screw (F) should be aligned with the label located on the dust port (E).
2. Tighten the set-screw when aligned to the arrow found on the label.

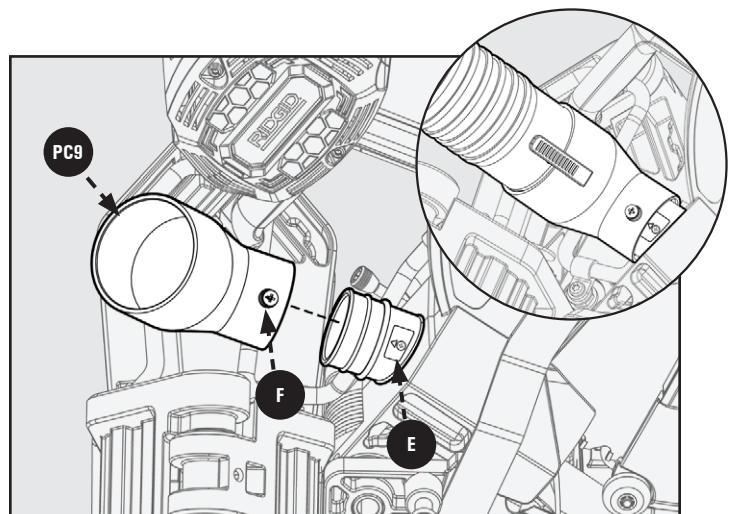

Figure 7

ASSEMBLY

INSTALL/REMOVE BLADE

⚠ WARNING: A 10 inch Blade is the maximum Blade capacity of the Saw. Larger Blades will come in contact with the Blade Guards.

See Figure 8.

1. Make sure the Saw is unplugged.
2. Raise the Saw Arm to the full upright position.
3. Rotate the Lower Blade Guard (A) up to expose the Blade Bolt (C). Hold the Lower Blade Guard with the Right thumb, and press the Spindle Lock Button (B) with the Right index finger at the same time.
4. If replacing the Blade, carefully rotate the blade until the spindle locks in place.

See Figure 9.

NOTE: To aid blade change, raise the lower guard and loosen the blade bolt cover screw a few turns to hold the lower guard up.

NOTE: Securely tighten the screw back in place when completing the blade change.

5. Using the supplied Blade Wrench, remove the Blade Bolt (C) by turning it clockwise.

NOTE: The Blade Bolt has left-hand threads.

6. Remove **ONLY** the Outer Blade Washer (D) and the Blade (E), leaving the Inner Blade Washer on the Spindle. See Figure 9.
7. Carefully fit Saw Blade inside the Blade Guard and guide it onto the Spindle, ensuring the Teeth of the Blade are facing down at the front of the Saw.
8. Align the double "D" Flats on the Blade Washer (D) with the flats on the Spindle and fit the Washer onto the Spindle.
9. Lock the Spindle by depressing the Spindle Lock Button. Screw in the Blade Bolt (C), remembering to thread it counterclockwise. Tighten Blade Bolt securely using the provided Blade Wrench.

⚠ WARNING: **ALWAYS** install the Blade with the Blade Teeth and the arrow on the side of the Blade pointing down at the front of the Saw. The direction of the Blade rotation is also stamped with an arrow on the Upper Blade Guard.

10. Raise and lower the Saw Arm to ensure that the Arm and Blade Guard move freely.

⚠ WARNING: Make sure the Spindle Lock Button (B), see Figure 8, is not engaged before reconnecting Saw to power source. **NEVER** engage Spindle Lock button when Blade is rotating.

NOTE: Some illustrations in this manual indicate **ONLY** portions of the Saw. This is done in order to more clearly show key areas and components of the Saw. **NEVER** operate the Saw without all Guards securely in place and in good operating condition.

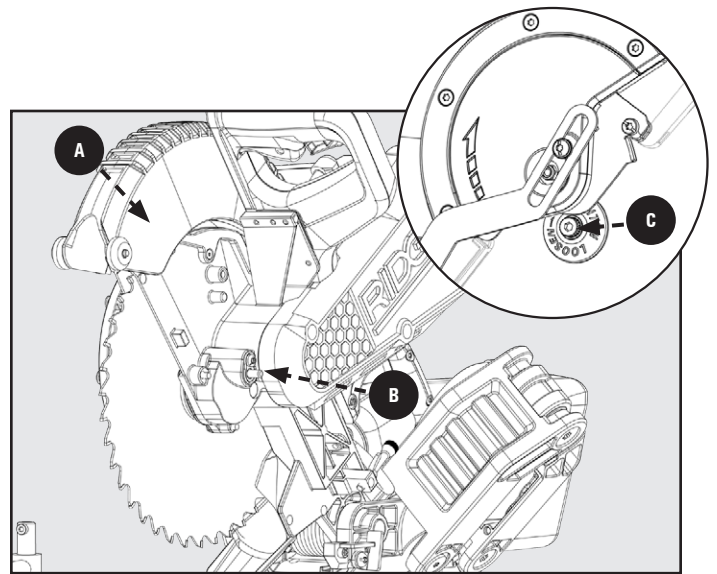

Figure 8

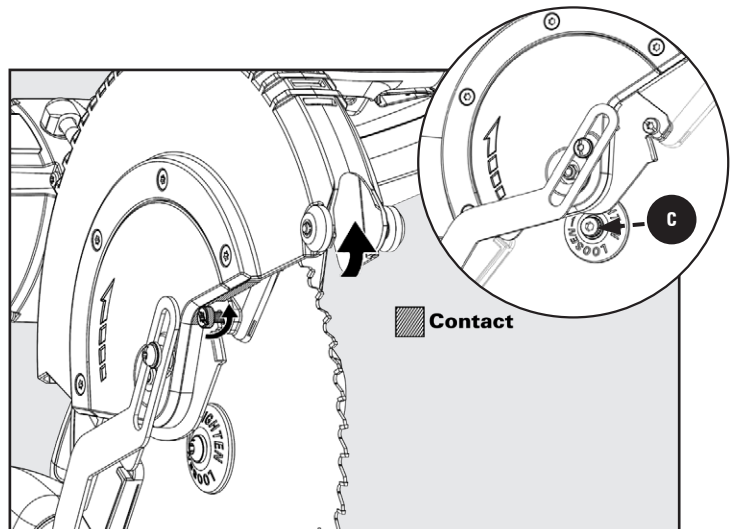

Figure 9

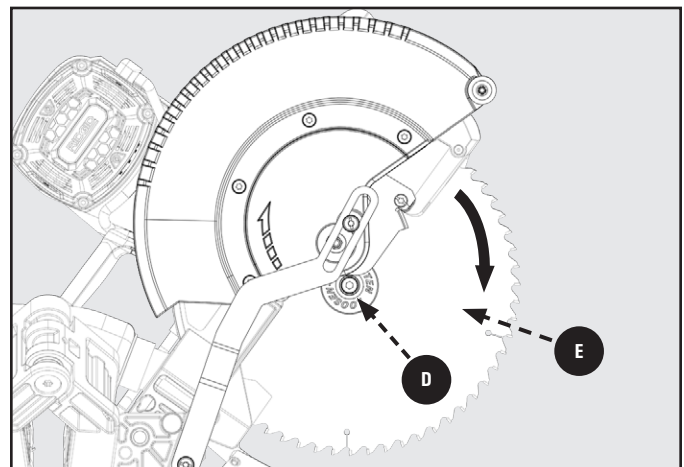

Figure 10

ADJUSTMENTS

ALIGN THE BLADE TO TABLE

Your saw is calibrated at the factory to cut true. Over time the saw's calibration may drift and will need to be re-calibrated.

See Figure 11.

1. Unplug the Saw.
2. Lower the saw head all the way down to the transport position and engage the saw head lock pin to hold it in place. Push the saw head into the fully retracted position and engage the slide prevention lock to hold it in place.
3. Set the miter position to 0° and engage the miter lock knob so the table will not move.
4. Set the bevel position to 0°. Engage the bevel latch lever, so the detent pin locks into the bevel detent plate.
5. Place a combination square (A) against the table and the face of the saw blade .

NOTE: Make sure the square contacts the flat part of the blade and not the teeth.

6. Rotate the blade by hand and check the blade-to-table alignment at several points. If the blade face is not flush with the square you will need to adjust the bevel detent plate (B).
7. Loosen the three screws (C) and adjust the bevel detent plate position. Set so the table and blade are flush against the combination square. Make sure the bevel lock/unlock handle is not locked, so the detent plate may be adjusted.
8. Re-tighten the three screws and re-check the blade-to-table alignment.

NOTE: After squaring adjustment have been made, it may be necessary to loosen the indicator screws (D) and reset them to zero.

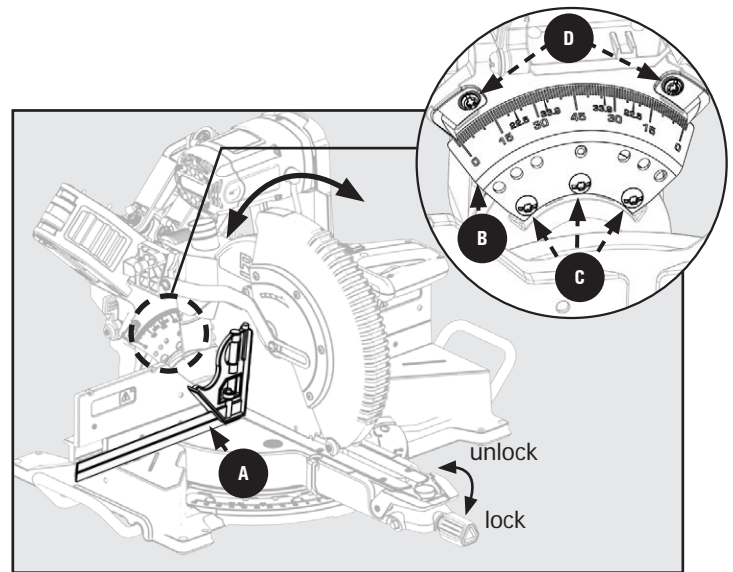

Figure 11

ADJUSTMENTS

ALIGN THE BLADE TO FENCE

Your saw is calibrated at the factory to cut true. Over time the saw's calibration may drift and will need to be re-calibrated.

See Figure 12.

1. Unplug the Saw.
2. Lower the saw head all the way down to the transport position and engage the saw head lock pin to hold it in place. Push the saw head into the fully retracted position and engage the slide lock lever to hold it in place.
3. Set the miter position to 0° and allow the miter detent to lock into position.
4. Set the bevel position to 0° . Engage the bevel lock handle to lock bevel angle.
5. Place a square (A) against the fence and the face of the saw blade.

NOTE: Make sure the square contacts the flat part of the blade and not the teeth.

See Figure 13.

6. If the blade face is not flush with the square you will need to adjust the miter detent plate (B).
7. Loosen the four screws (C) and move the miter table to adjust the miter detent plate position. Set so the fence and blade are flush against the combination square. Make sure the miter lock knob is not locked, so the miter detent plate may be adjusted.
8. Re-tighten the four screws and re-check the blade-to-fence alignment.

NOTE: After squaring adjustment have been made, it may be necessary to loosen the indicator screws (D) and reset them to zero.

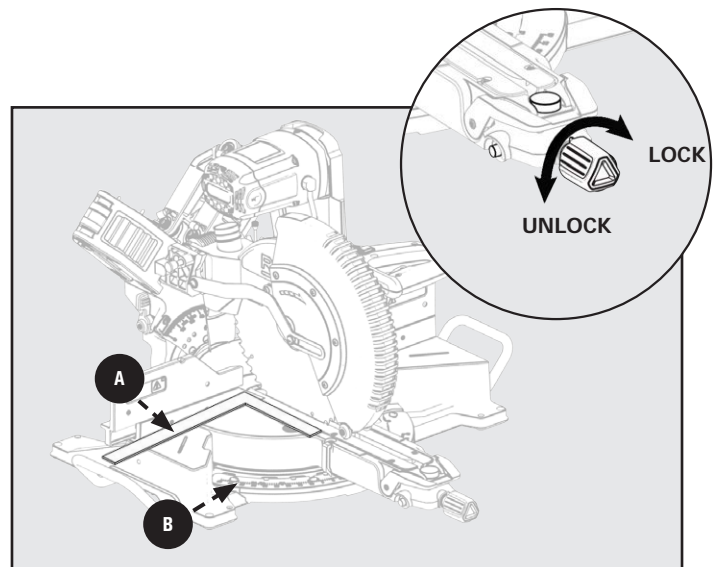

Figure 12

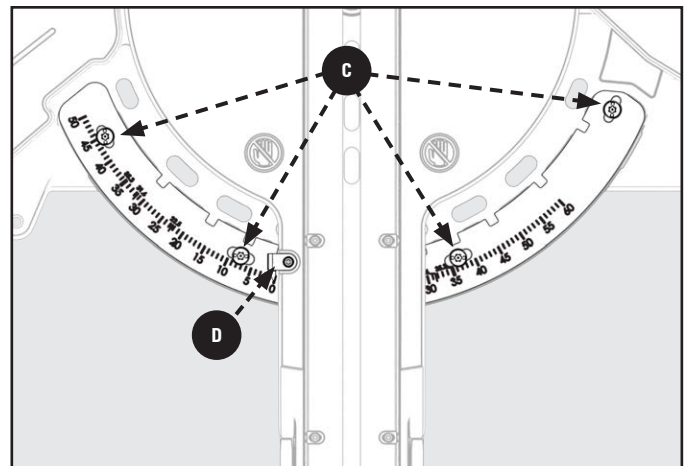

Figure 13

ADJUSTMENTS

DEPTH STOP ADJUSTMENT

This miter saw is equipped with an adjustable depth stop for making non-through cuts.

Refer to Figure 14 and follow these instructions in order to set the depth stop at a specific cut depth:

1. Rotate the stop bracket (A) counterclockwise into the down position.
2. The cut depth can now be adjusted by turning the depth adjustment screw (B).
3. Lock the adjustment screw by turning the Wing-Nut (C) until snug against the stop bracket (A).

Note: When finished with non-through cut, rotate stop bracket (A) clockwise to return to through cut position.

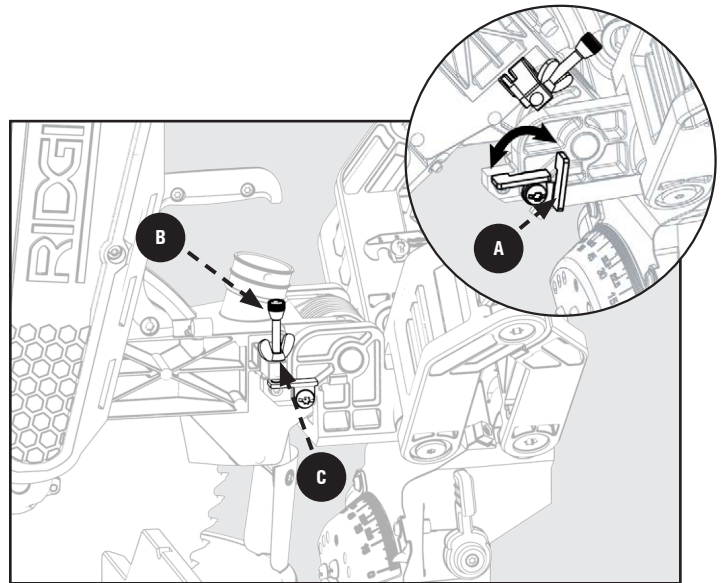

Figure 14

FENCE EXTENSION

See Figure 15.

This saw is equipped with an adjustable sliding fence. To extend or retract the fence follow these instructions:

1. Loosen the lock knob (D) by rotating counterclockwise and then slide the fence (E) into the desired position.
2. Make sure to re-tighten lock knob (D) by rotating clockwise.

⚠ DANGER: ALWAYS check to make sure lock knob (D) is tightened before making a cut. Failure to do so may result in injury.

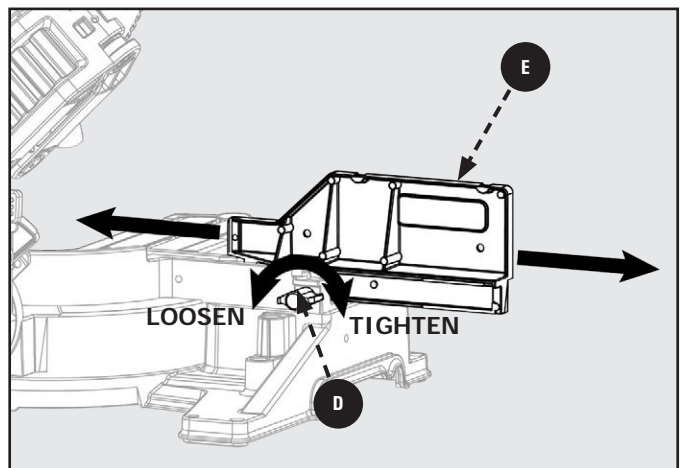

Figure 15

BEVEL LOCK TENSION ADJUSTMENT

See Figure 16.

1. Use supplied Torx/blade wrench. Adjust the bevel lock tension by tightening/loosening the T30 pivot bolt (F) located on the backside of the saw.
2. Make sure to loosen the bevel lock/unlock handle before adjusting the T30 pivot bolt. **DO NOT** over-tighten.

NOTE: Correct tension is when the cutting head will hold position when not indexed and unlocked. This only applies at angles 0 - 20°.

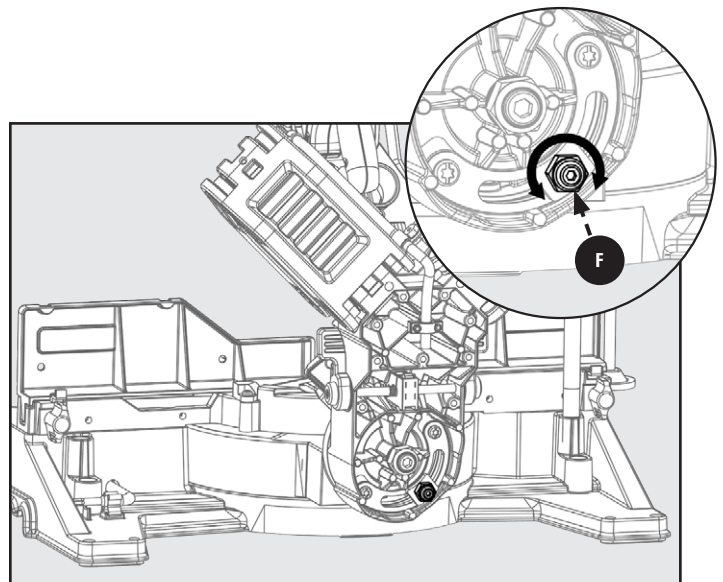

Figure 16

ADJUSTMENTS

SLIDE RESISTANCE

See Figure 17.

The slide resistance (friction) on your saw is adjustable. Use a 4mm Hex wrench.

1. Locate the friction adjustment screw on the saw arms (A). Turn right to tighten the sliding friction.
2. Turn left to loosen the sliding friction.

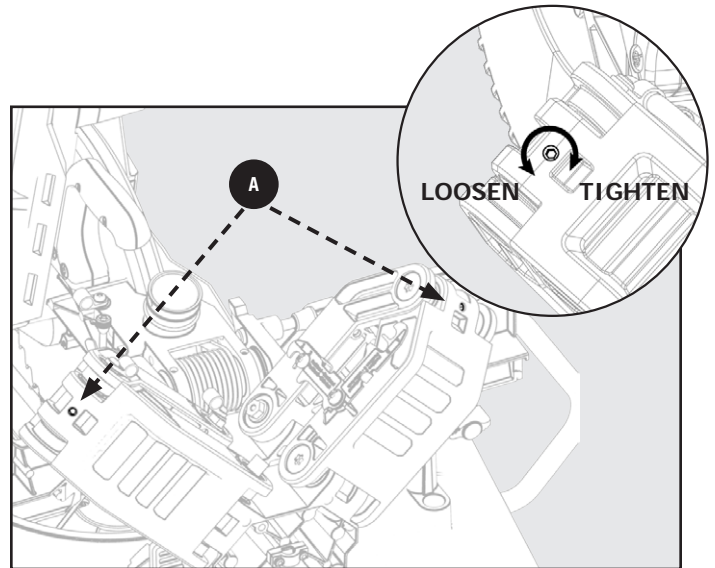

Figure 17

MITER LOCK ADJUSTMENT

See Figure 18.

If your saw's miter lock does not lock securely, you may be required to tighten the miter lock adjustment. This adjustment is located on the underside of the miter saw arm. To make adjustments:

1. First unlock the miter lock knob. Use a 10mm open ended wrench to loosen (counterclockwise) lock nut (B) while holding the adjustment rod (C) in place using another 10mm open end wrench.
2. Turn the adjustment rod in order to tighten/loosen the miter lock.
3. Lock/Unlock the miter lock knob to check the miter lock adjustment.
4. Once you have set your miter lock adjustment re-tighten the lock nut (B) to prevent this adjustment from loosening over time.

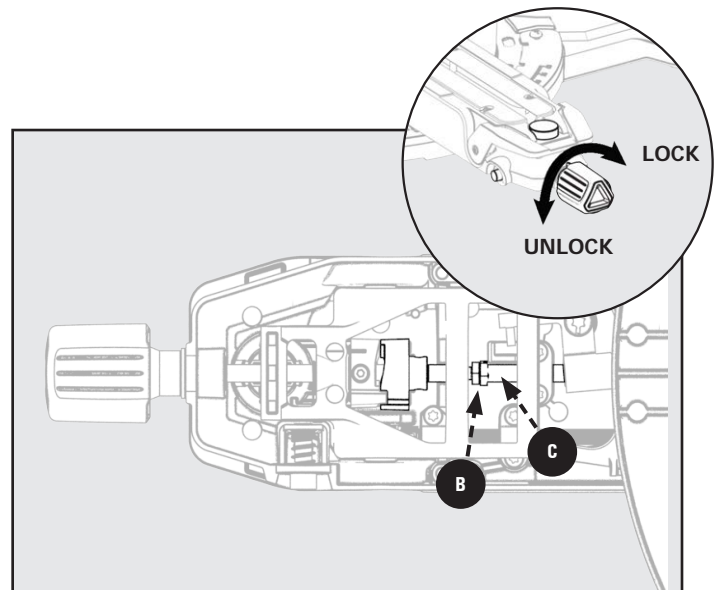

Figure 18

⚠ WARNING: ALWAYS check to make sure the miter lock is locked tightly into position before using your saw. Failure to follow these instructions could result in the miter lock slipping during use of the saw.

ADJUSTMENTS

THROAT PLATE

See Figures 19.

⚠ WARNING: ONLY use RIDGID® authorized service parts. Using non-authorized parts can result in damage to your machine and serious personal injury.

In the event that your throat plate needs to be replaced for any reason, follow these instructions.

1. Loosen the fence lock knobs. Slide both of the upper (adjustable) fences completely off the lower (fixed) fence.
2. Remove the six screws (A) which hold the throat plate. Lift the throat plate off the miter arm.
3. Replace the throat plate only using a RIDGID® authorized service part.
4. Tighten the six screws (A) which hold the throat plate.

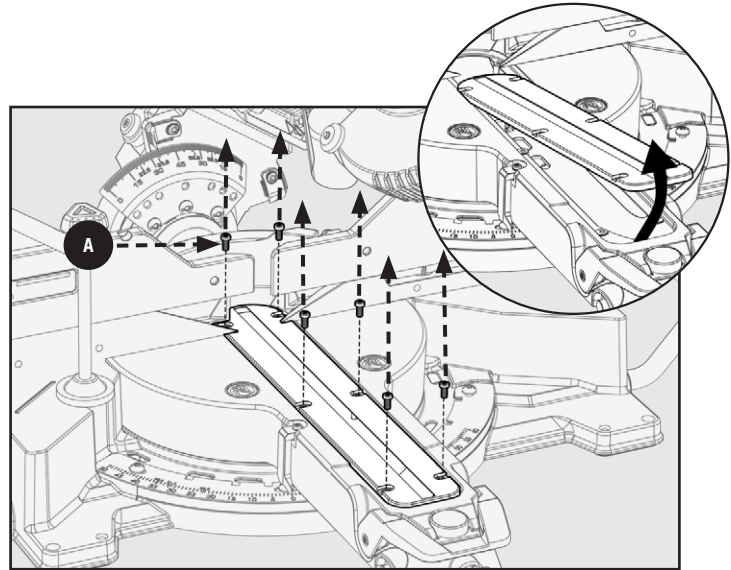

Figure 19

MOUNTING AND TRANSPORTATION

⚠ WARNING: Before moving/transporting your saw it is important to make sure all of the following steps have been followed to ensure a safe condition for transportation. Failure to do so can result in serious personal injury.

⚠ WARNING:

- **ALWAYS** turn the power off and unplug saw before transporting.
- Secure power cord to avoid any snags or hang ups during transportation.
- **ALWAYS** lift using the strength of your legs to lift saw; never use your back muscles to lift saw.
- **DO NOT** use power On/Off switch handle or power cord to lift your saw.
- **ALWAYS** place the saw onto a stable and level surface with clearance for handling and maneuvering.

PREPARATIONS FOR TRANSPORTATION

SAW HEAD LOCK PIN

See Figure 20.

ALWAYS lock saw head in the down position before transporting saw. To engage saw head lock pin (A): Push saw head to the down position then push-in lock pin.

⚠ WARNING: Saw Head lock pin is for storage and transport only. This saw should never be locked in the down position while making cuts.

SLIDE LOCK

See Figure 20.

ALWAYS engage the slide lock (B) before transporting this saw. To engage slide lock: Push saw head to the fully retracted position then swing the slide lock lever down.

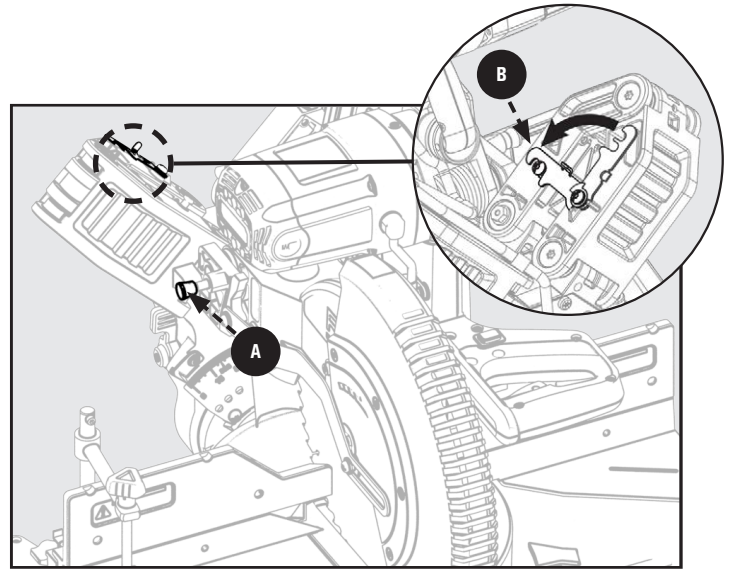

Figure 20

CARRY HANDLE

See Figure 21.

For transportation use the included carry handle (C). You may also lift using the cast-in handle cut-outs (D) on both sides of the saw base.

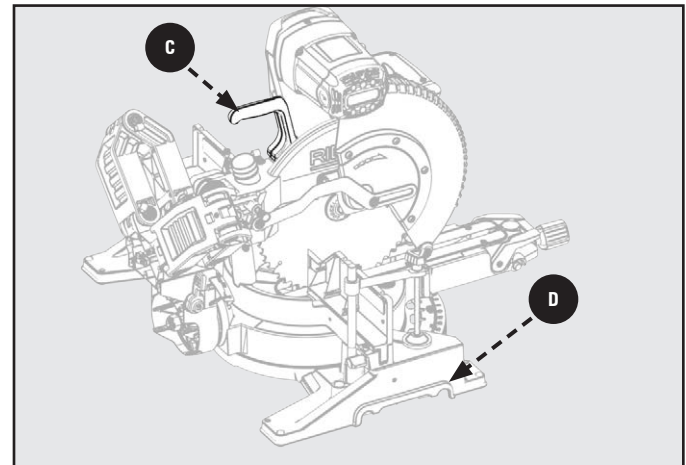

Figure 21

MOUNTING AND TRANSPORTATION

MOUNTING SAW TO STABLE SURFACE

See Figure 22.

⚠ WARNING: To ensure safe and accurate operation, this saw should be mounted to a stable and level surface such as a workbench. To mount the tool to a stable surface, do the following:

1. Locate the four mounting holes (A) in the base of the saw.
2. Secure the tool to the mounting surface using 3/8 inch diameter machine bolts, lock washers, and hex nuts (not included). Make sure the bolts are long enough to accommodate the saw base, lock washers, hex nuts, and the thickness of the workbench.
3. Tighten all four bolts securely.
4. Check to make sure that the saw is secure before operation.

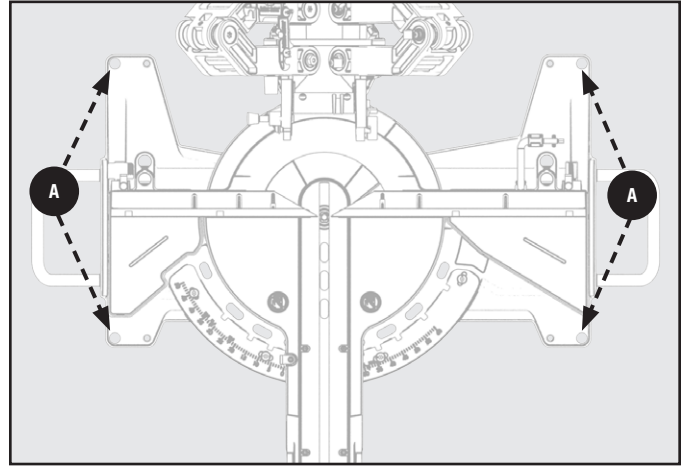

Figure 22

INSTALLING WORKPIECE SUPPORT EXTENSIONS

See Figure 23

To assemble the support extensions:

1. Insert one of the support extensions (PC5) to the underside of the base at the cast-in handle cut-outs (B).
2. Make sure support extension (PC5) is flush with the base and inserted into the rounded slots of the cut-outs (B). The rivets (C) are used to prevent the support extension (PC5) from sliding out of the base during use. These rivets should be positioned on the inside of the base.
3. Place the extension clamp (PC6) onto the support extension and the screw that is pre-attached to the base.
4. Once the extension clamp (PC6) is in place, put the spring washer (PC7) first and screw the wing nut (PC8) provided onto the screw.
5. Tighten the wing nut (PC8) to fully secure the support extension (PC5).
6. Repeat on the other side.

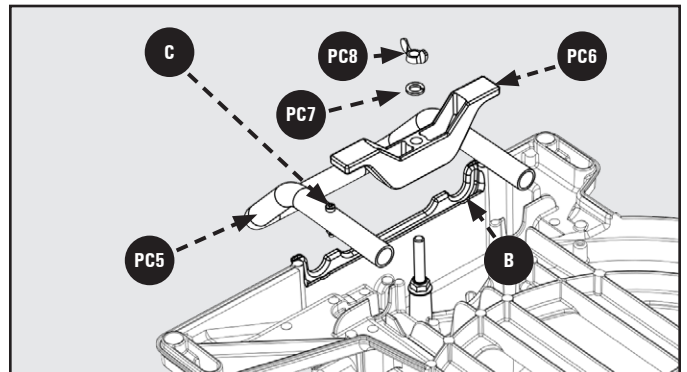

Figure 23

OPERATION

⚠ WARNING:

- **DO NOT** allow familiarity with tools to make you careless. Remember that a careless fraction of a second is sufficient enough to inflict serious personal injury.
- **ALWAYS** wear eye protection with side shields and marked to comply with ANSI Z87.1 Failure to do so could result in objects being thrown into your eyes, resulting in possible serious personal injury.
- **DO NOT** use any attachments or accessories not recommended by the manufacturer of this tool. The use of attachments or accessories not recommended can result in serious personal injury.
- Before starting any cutting operation, clamp or bolt the compound miter saw to a workbench. **NEVER** operate the miter saw on the floor or in a crouched position. Failure to heed this warning can result in serious personal injury.
- To avoid serious personal injury, **ALWAYS** tighten the miter lock handle and bevel lock knob securely before making a cut. Failure to do so could result in movement of the control arm or miter table while making a cut.
- To avoid serious personal injury, **KEEP** hands outside the no hands zone, at least 4 inches from blade. **NEVER** perform any cutting operation freehand (without holding workpiece against the fence). The blade could grab the workpiece if it slips or twists.
- When using a work clamp or C-clamp to secure the workpiece, clamp workpiece on one side of the blade only. The workpiece **MUST** remain free on one side of the blade to prevent the blade from binding in workpiece. The workpiece binding the blade will cause motor stalling and kickback. This situation could cause an accident resulting in serious personal injury.
- **NEVER** move the workpiece or make adjustment to any cutting angle while the saw is running and the blade is rotating. Any slip can result in contact with the blade causing serious personal injury.
- When cutting, **DO NOT** force the blade against the workpiece. Forcing the blade will cause a drop in motor RPM and increase the risk of overheating the saw blade tips.

You may use this tool for the following purposes:

- Bevel cutting and compound cutting for crown moldings, etc.
- Cross cutting wood.
- Cross cutting for moldings, door casings, picture frames, etc.

NOTE: This saw is for cutting wood. The blade provided is acceptable for wood cutting **ONLY**.

CUTTING WARPED MATERIAL

See Figure 24.

When attempting to cut warped material, the CONVEX face should be against the fence.

See Figure 25.

NEVER position a piece of warped material with the CONCAVE face or edge against the fence. It will pinch the blade near the completion of the cut.

⚠ WARNING: To avoid a kickback and to avoid serious personal injury, **NEVER** position the concave edge of bowed or warped material against the fence.

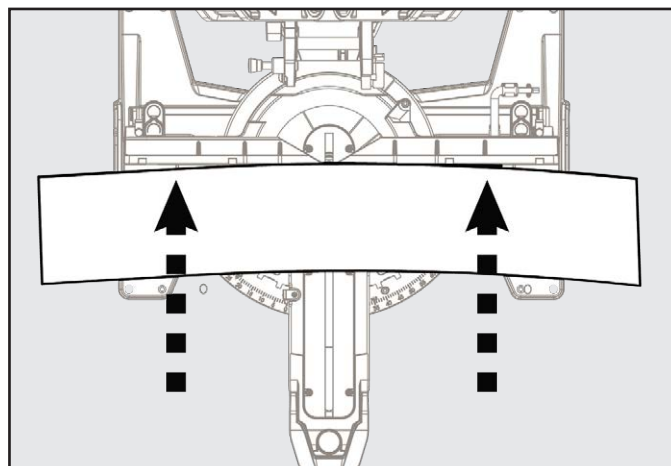

Figure 24

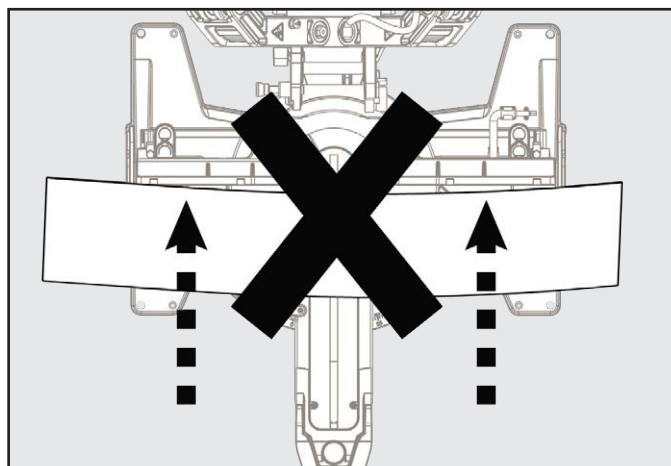

Figure 25

OPERATION

CLAMPING WIDE WORKPIECES

See Figure 26.

1. When cutting wide work pieces, such as 2 X 12 inch, clamp the workpiece to the work table using a work clamp (PC3) .

⚠ WARNING: KEEP clamps away from the path of the blade and blade guard assembly.

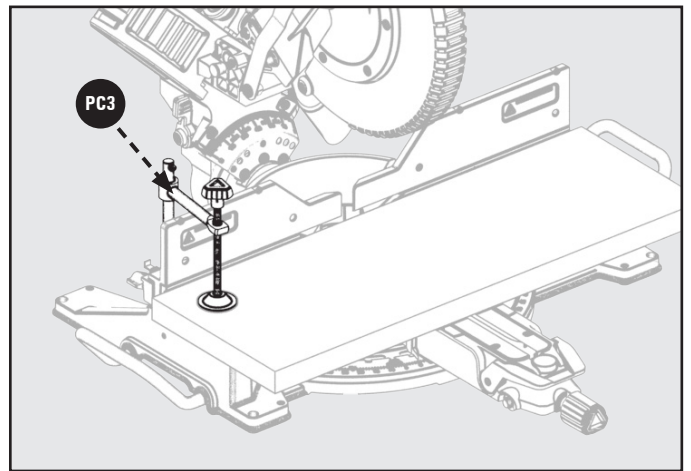

Figure 26

SUPPORTING LONG WORKPIECES

See Figure 27.

1. In most cases the included table extensions (workpiece supports) will be sufficient to support longer workpieces. If these are not long enough, the workpiece should be supported further out from the saw. Additional support (A) may be used to make the workpiece lay flat on the saw table. Use the included work clamp or a C-clamp (B) to secure the workpiece to the miter saw table.

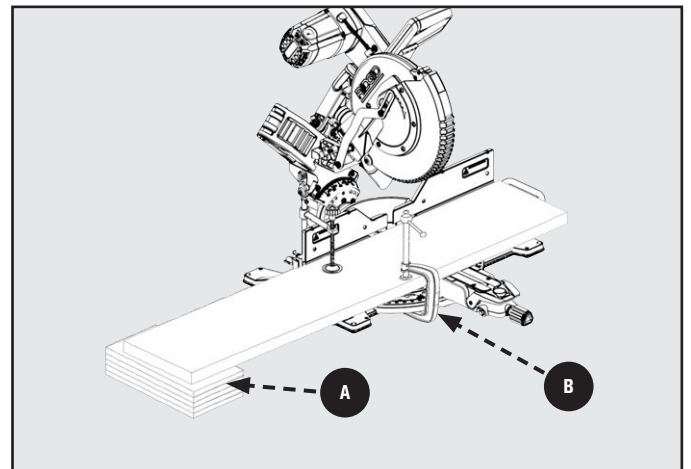

Figure 27

OPERATION

POWER SWITCH LOCK

See Figure 28

To prevent any unauthorized person from operating this saw, a padlock (not included) should be installed into the lock hole located on the power switch. Be sure padlock is fully closed and locked before leaving this saw unattended. Safety switch (A) needs to be engaged prior to operation of the machine.

⚠ WARNING: **ALWAYS** disconnect the power supply before installing or removing a lock onto the power switch. Failure to do so could cause the power switch to engage by accident, resulting in serious injury.

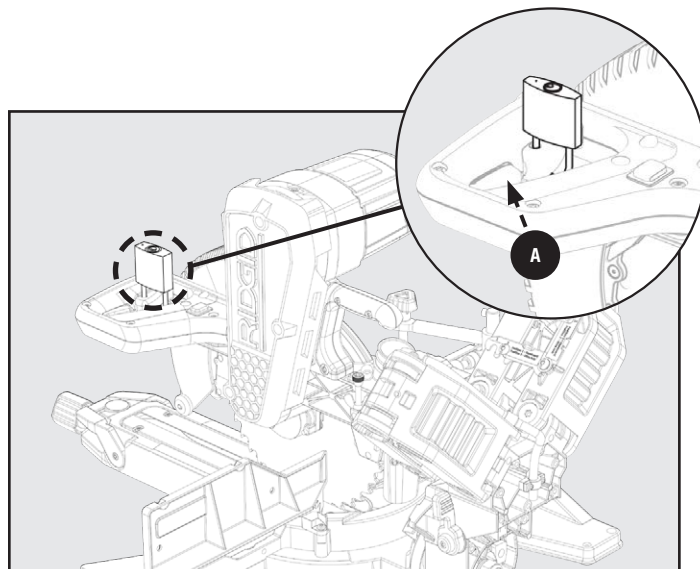

Figure 28

SHADOW LINE

See Figure 29.

1. To activate the shadow line feature, turn on the shadow guide on/off switch (F3) located on top of the handle.

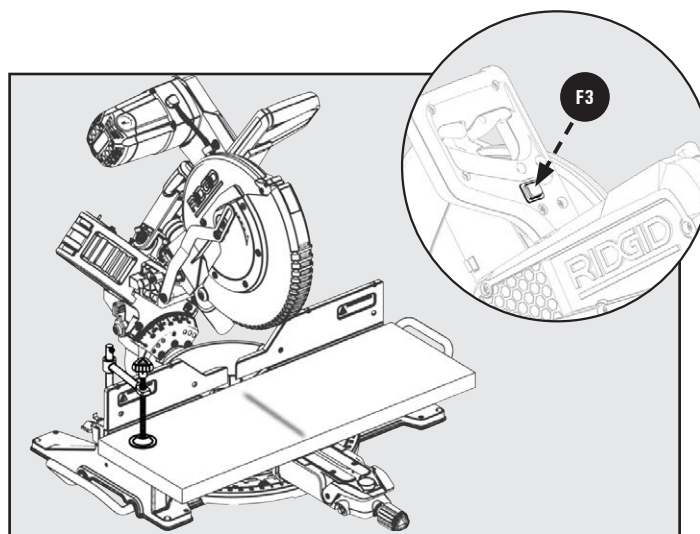

Figure 29

OPERATION

⚠ WARNING: Before turning the saw power ON, check to make sure saw head and blade will not make contact with the provided work clamp or fence during the cutting operation. Position the work clamp and fence to avoid contact with the miter saw head.

NON-SLIDING CUTS

⚠ WARNING: ALWAYS engage the slide prevention lock before making any non-sliding cuts. Failure to engage this lock could result in saw head movement during the cutting operation.

FOR CROSS CUTS

See Figure 30 and 31.

1. To use this saw as a traditional, non-sliding, miter saw: slide the saw head into the fully retracted position and engage the slide lock (A), baseboard notch. See Figure 30.
2. Loosen the miter lock knob (C), use your thumb to push in the miter detent lock button (B), and set the miter arm angle to 0°. Use the miter scale (E) and indicator (F) to locate the 0° miter position.
3. Release the miter detent lock button (B) and tighten the miter lock knob (C). Check that saw head is securely locked into position.
4. Raise the saw head to its UP position.
5. Position the workpiece so that it is securely supported by the work table and fence. If the board is warped, read and follow the instructions under "Cutting Warped Material" in the "Operation" section of this manual.
6. Secure the workpiece to the table and against the fence, using the provided clamp.
7. Before turning the power switch ON, perform a simulated cut to check your cut alignment. Also check to make sure the blade will not come into contact with the provided work clamp or anything other than the workpiece.
8. Engage the power ON switch. Allow the blade to reach maximum speed.
9. Lower the saw blade through the workpiece.
10. Disengage the power switch and allow blade to come to a complete stop before raising the saw head.

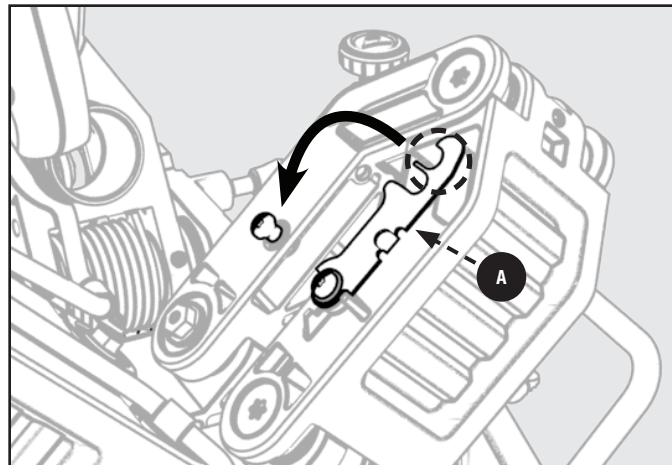

Figure 30

MITER CUTS

⚠ WARNING: Before turning the saw power ON, check to make sure saw head and blade will not make contact with the provided work clamp or fence during the cutting operation. Position the work clamp and fence to avoid contact with the miter saw head.

⚠ WARNING: ALWAYS tighten the miter lock knob (C) before any cutting operation. Failure to do so may result in serious personal injury.

See Figure 31.

1. Follow Operation instructions "Non-Sliding Cuts" in previous manual section. Include the following adjustments before cutting.
2. Rotate miter arm to one of the preset miter angles (0°, 15°, 22.5°, 31.6°, or 45°).
3. Use the miter detent override button (D) if your desired angle position is not provided.

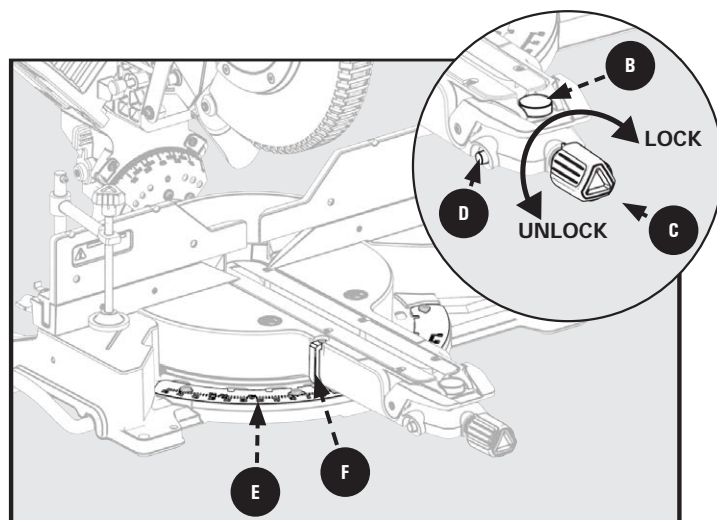

Figure 31

OPERATION

BEVEL CUTS

⚠ WARNING: Before turning the saw power ON, check to make sure saw head and blade will not make contact with the provided work clamp or fence during the cutting operation. Position the work clamp and fence to avoid contact with the miter saw head.

⚠ WARNING: **ALWAYS** lock the bevel lock handle before any cutting operation. Failure to do so may result in serious personal injury.

See Figure 32.

1. Follow Operation instructions “Non-sliding Cuts” in previous manual section. Include the following adjustments before cutting.
2. Loosen fence lock knob (A), on left and right side, and slide adjustable fence (B) to allow proper spacing for bevel cuts. Once proper spacing is set tighten fence lock knobs.
3. Lift the bevel lock handle (C).
4. While firmly supporting the saw head with one hand, push back the bevel detent latch lever (D) and swing the saw head left or right to the required bevel angle.
5. If you are using one of the bevel detent positions, check to make sure the bevel detent latch lever and bevel detent (E) locks into the positive stop plate.
6. If you are using a bevel angle that is not one of the common bevel detent positions. Rotate the saw to the desired bevel angle and use the bevel lock handle (C) to lock the head in place.
7. Push down the bevel lock handle to lock bevel position.

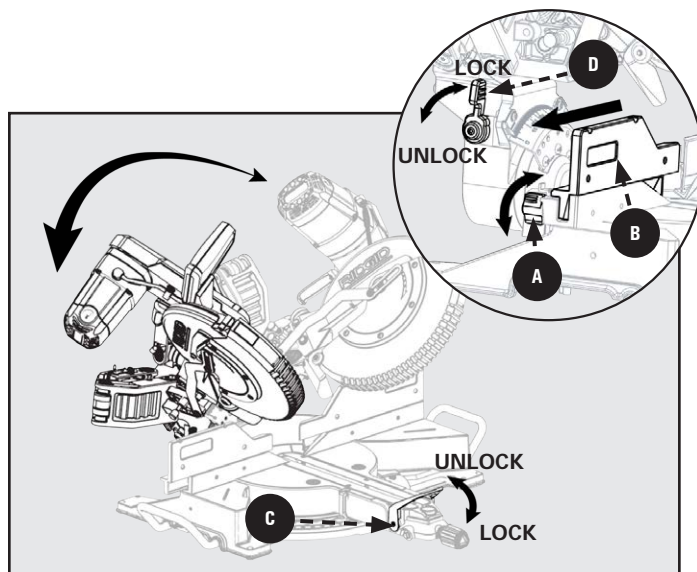

Figure 32

COMPOUND MITER CUTS

⚠ WARNING: Before turning the saw power ON, check to make sure saw head and blade will not make contact with the provided work clamp or fence during the cutting operation. Position the work clamp and fence to avoid contact with the miter saw head.

See Figure 33.

A compound miter cut uses a combination of a miter angle adjustment and bevel angle adjustment. Use the instructions from “Miter Cuts” and “Bevel Cuts” to set your bevel and miter angle before performing the “Non-sliding Cuts” operation instructions above

NOTE: The miter angle and bevel angle are dependent upon each other. If you adjust one of these it will change the other. **ALWAYS** check both angles after making any adjustments.

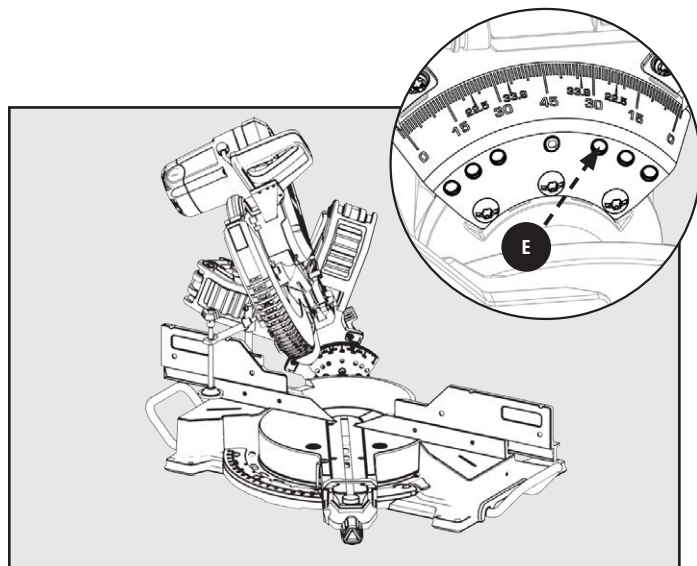
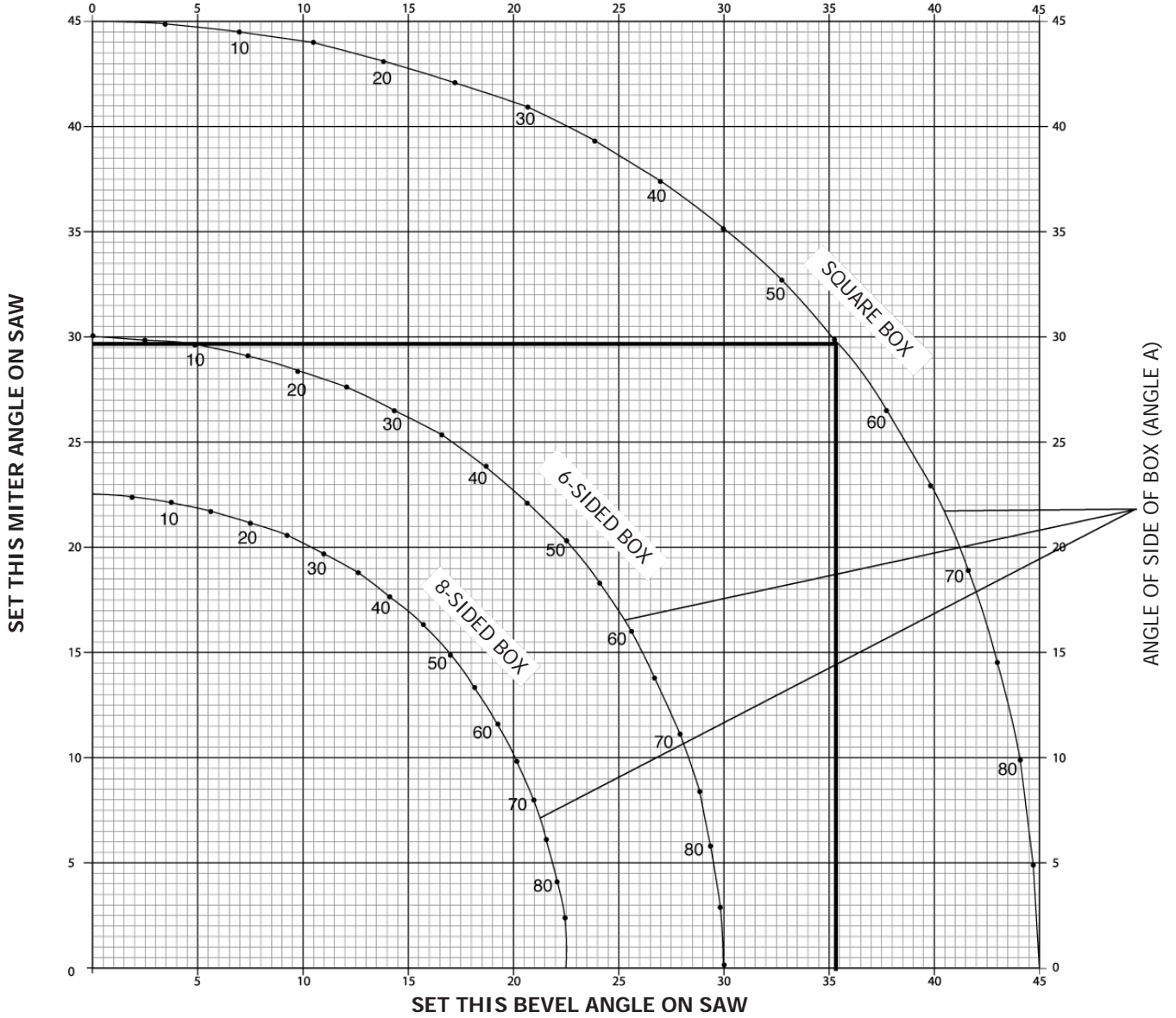

Figure 33

OPERATION

TABLE 1: COMPOUND MITER CUT

(POSITION WOOD WITH BROAD FLAT SIDE ON THE TABLE AND THE NARROW EDGE AGAINST THE FENCE)



OPERATION

SLIDE CUTS

See Figures 34 and 35.

⚠ WARNING: A slide cut should **NEVER** be performed by pulling the saw toward you. Due to the blade rotation direction, this can cause the saw blade to climb over the workpiece and towards the operator. Failure to follow this warning could result in serious personal injury.

⚠ WARNING: Before turning the saw power ON, check to make sure saw head and blade will not make contact with the provided work clamp or fence during the cutting operation. Position the work clamp and fence to avoid contact with the miter saw head.

To use this saw to make slide cuts follow the instructions below. Slide cuts must **ONLY** be performed by pushing the saw blade away from you and toward the back of the saw, stopping at the fully RETRACTED position after each cut. See warning above.

1. Check to make sure the slide lock (A) and head lock pin (B) is not engaged. Raise the saw head to its UP position.
2. Position the workpiece so that it is securely supported by the saw table and fence. If the board is warped, read and follow the instructions under "Cutting Warped Material" in the "Operation" section of this manual.
3. Secure the workpiece to the table and against the fence, using the provided clamp.
4. Before turning the power switch ON, perform a simulated cut to check your cut alignment. Also check to make sure the blade will not come into contact with the provided work clamp or anything other than the workpiece.
5. Before turning the power switch ON, pull the saw arm towards you until the blade is beyond the front edge of your workpiece or until the saw arm is in the fully EXTENDED position. The saw head should be in the full UP position.
6. Engage the power ON switch. Allow the blade to reach maximum speed.
7. Lower the saw blade through the workpiece and push the saw head towards the fully RETRACTED position.
8. Disengage the power switch and allow blade to come to a complete stop before raising the saw head.

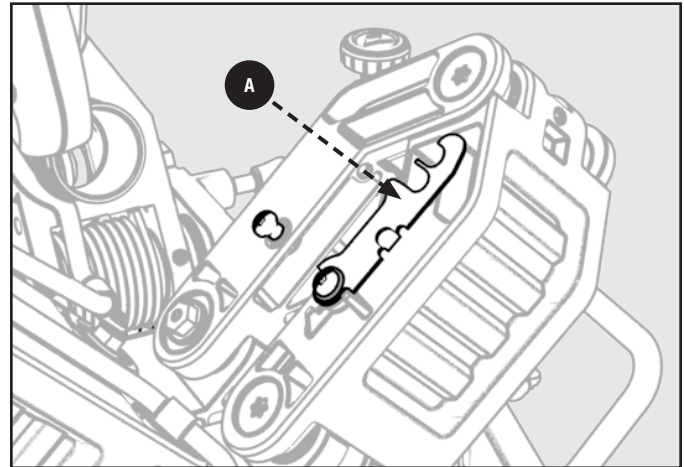

Figure 34

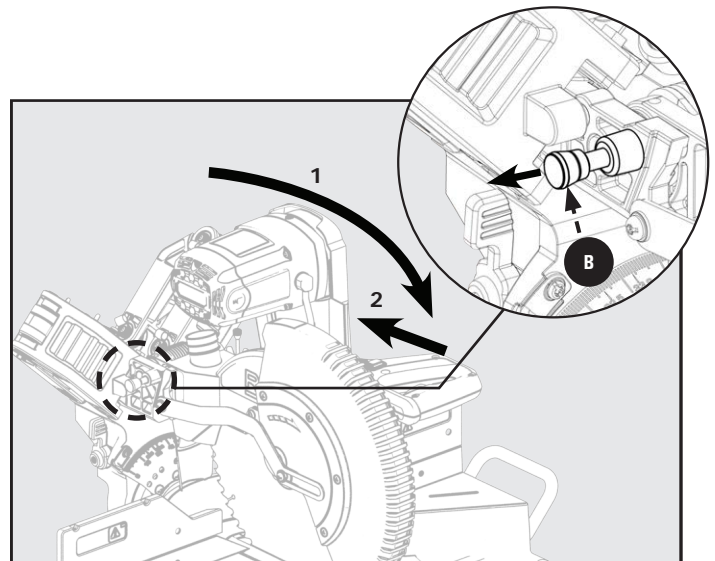

Figure 35

OPERATION

TIPS FOR CUTTING CROWN MOLDING

- The two edges of the molding that contact the ceiling and the wall are at angles that, when added together, equal exactly 90°. Most crown molding has a top rear angle (the section that fits flat against the ceiling) of 52° and a bottom rear angle (the section that fits flat against the wall) of 38°.
- To accurately cut crown molding for a 90° inside or outside corner, lay the molding with its broad back surface flat on the miter table and against the fence.
- The angles for crown moldings must be very precise. The bevel and miter angles are interdependent; changing one angle changes the other angle as well.
- Since it is very easy for the work piece to shift, all settings should first be tested on scrap molding. Also most walls corners do not have angles of exactly 90°; therefore, you will need to fine-tune your settings.
- When cutting crown molding the bevel angle should be set at 33.85°.
- The miter angle should be set at 31.62° either right or left, depending on the desired cut for the application. See the chart on next page for correct angle settings and correct positioning of crown molding on the work table.

Bevel Angle Setting	Type of Cut	Steps
33.85°	Left side, inside corner	1. Top edge of molding against fence 2. Miter table set right 31.62° 3. Save left end of cut
33.85°	Right side, inside corner	1. Bottom edge of molding against fence 2. Miter table set left 31.62° 3. Save left end of cut
33.85°	Left side, outside corner	1. Bottom edge of molding against fence 2. Miter table set left 31.62° 3. Save right end of cut
33.85°	Right side, outside corner	1. Top edge of molding against fence 2. Miter table set right 31.62° 3. Save right end of cut

OPERATION

AUXILIARY FENCE

See Figure 36

For cutting certain workpieces, you may require a larger fence surface area to accommodate the workpiece. The auxiliary fence should be made using 3/4 inch thick wood. Use the mounting holes (in bold) which are pre-drilled in the fence to attach an auxiliary fence.

⚠ WARNING: NEVER use auxiliary fence which interferes or makes contact with saw head. ALWAYS check for clearance between auxiliary fence and saw head before making cuts.

⚠ WARNING: To make slide cuts using an auxiliary fence, a notch MUST be cut out in the auxiliary fence prior to attaching to saw fence.

⚠ WARNING: The auxiliary fence can ONLY be used with the 0° bevel angle. Remove the auxiliary fence before making a bevel cut.

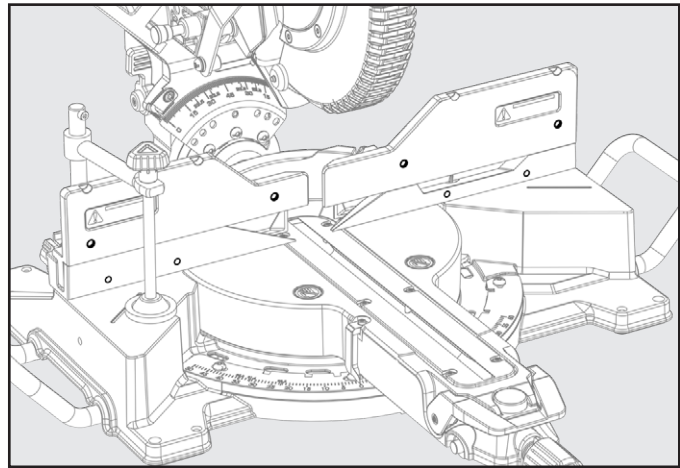

Figure 36

See Figure 37 for auxiliary fence dimensions.

1. Place auxiliary fence wood against miter saw fence. See Figure 36. The maximum height for this wood **MUST NOT** exceed 5.5 inch. Check to make sure auxiliary fence does make contact with saw head, check with saw head in the full DOWN and fully RETRACTED position.
2. Mark the hole locations on the backside of the auxiliary fence board.
3. Drill the marked hole locations all the way through the auxiliary fence. Countersink the drilled holes on the front side of your auxiliary fence board.
4. Fasten the auxiliary fence using flat head screws. Secure from behind using flat washers and nuts.
5. Make a full depth cut through the auxiliary fence, to create the blade slot.
6. The notch shown in Figure 37 must be cut out in order to make slide cuts using the auxiliary fence.

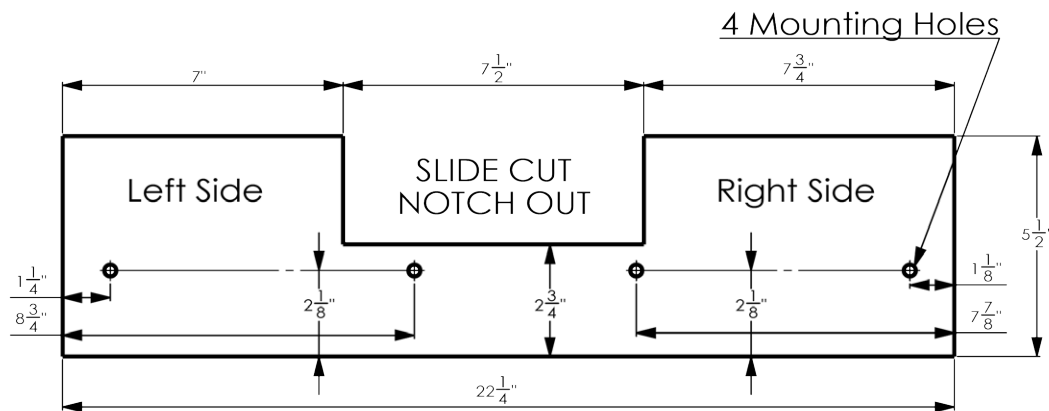

Figure 37

OPERATION

EXPAND WORKTABLE AREA

This saw is designed to allow for large capacity cuts up to (2 x 16 inch). In order to make these cuts you will need to configure your saw appropriately.

⚠ WARNING: DO NOT use an auxiliary table board which will not fully support the workpiece during cutting operation.

1. Loosen the fence lock knob (A). Slide the upper (adjustable) fence completely out of its track and set to the side. See Figure 38. (Both fences need to be removed).
2. Flip the support tabs (C & D) into position. Tabs (D) are on both the left and right sides of the lower (fixed) fence. Tab (C) only exists on the right side of the lower (fixed) fence. These will function as your workpiece backstop. See Figure 40.
3. You will need to add a 2x12 (1-1/2 x 11-5/8) auxiliary table board (E) to support your large capacity workpiece (F). See Figure 40.

NOTE: The Auxiliary Table Board should be as wide as the lower (fixed) fence and secured to the lower fence using wood screws, see Figure 39.

4. Use the support tabs (C & D) to support the back of your workpiece before making any cuts.

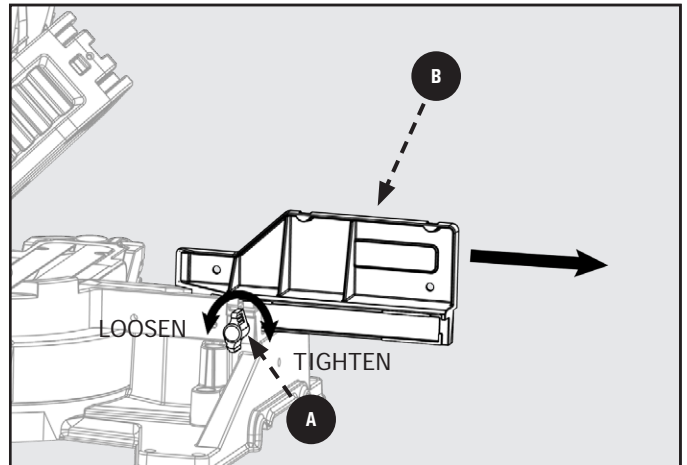

Figure 38

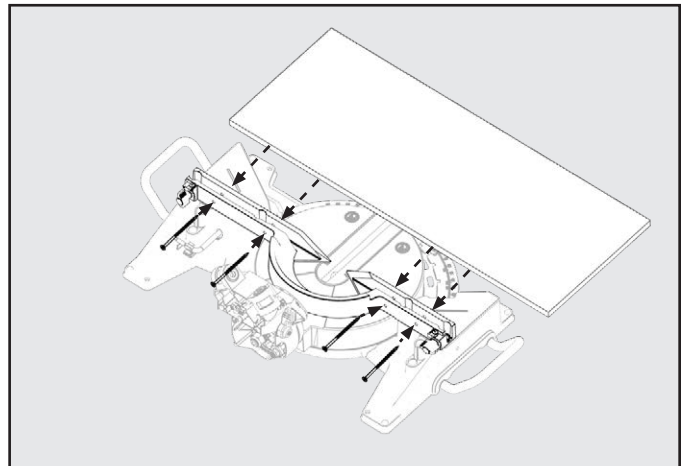

Figure 39

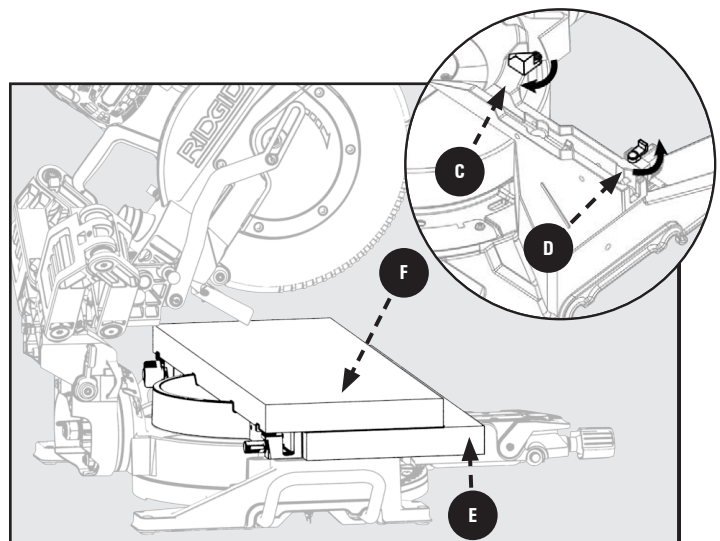

Figure 40

MAINTENANCE

⚠ WARNING: To reduce the risk of injury, turn unit off and disconnect it from power source before cleaning or servicing, before installing and removing accessories, before adjusting when making repairs. An accidental start-up can cause injury.

KEEP MACHINE CLEAN

⚠ WARNING: Periodically blow out all air passages with dry compressed air. All plastic parts should be cleaned with a soft damp cloth. **NEVER** use solvents to clean plastic parts. They could possibly dissolve or otherwise damage the material. Wear certified safety equipment for eye, hearing and respiratory protection while using compressed air.

Empty dust bag frequently.

When servicing, use only identical replacement parts. Use of any other parts may create a hazard or cause product damage.

GENERAL MAINTENANCE

Avoid using solvents when cleaning plastic parts. Most plastics are susceptible to damage from various types of commercial solvents and may be damaged by their use. Use clean cloths to remove dirt, dust, oil, grease, etc.

BRUSH REPLACEMENT

The motor on this saw features externally accessible brush assemblies that should be periodically checked for wear. If the brushes need to be replaced, see to Figure 41 and proceed as follows:

1. Unplug the saw.
2. **⚠ WARNING:** Failure to unplug the saw could result in accidental starting causing serious personal injury.
3. Loosen Screws (A) and remove motor end cap (B). Using a flathead screwdriver carefully remove the brush cap (F18).

NOTE: Remove the cap slowly. The brush assembly is spring-loaded and will pop out once the cap is removed.

4. Remove brush assembly (D).
5. Inspect both brushes. If either has less than 1/4 inch length of carbon remaining, both brushes should be replaced.

NOTE: DO NOT replace one side without replacing the other.

6. Insert both brushes into the brush tubes (E), making sure the curvature of the brushes matches curvature of motor. Brush assembly should move freely within the tube.
7. Carefully replace the brush cap, ensuring that it is not cross-threaded.
8. Tighten brush cap securely. **DO NOT** over-tighten.

⚠ WARNING: **DO NOT** at any time let brake fluids, gasoline, petroleum-based products, penetrating oils, etc., come in contact with plastic parts. Chemicals can damage, weaken or destroy plastic which may result in serious personal injury.

Electric tools used on fiberglass material, wallboard, spackling compounds, or plaster are subject to accelerated wear and possible premature failure because the fiberglass chips and grindings are highly abrasive to bearings, brushes, commutator, etc. Consequently, we **DO NOT** recommend using this tool for extended work on these types of materials. However, if you do work with any of these materials, it is extremely important to clean the tool using compressed air.

LUBRICATION

All of the bearings in this tool are lubricated with a sufficient amount of high-grade lubricant for the life of the unit under normal operating conditions. Therefore, no further lubrication is required.

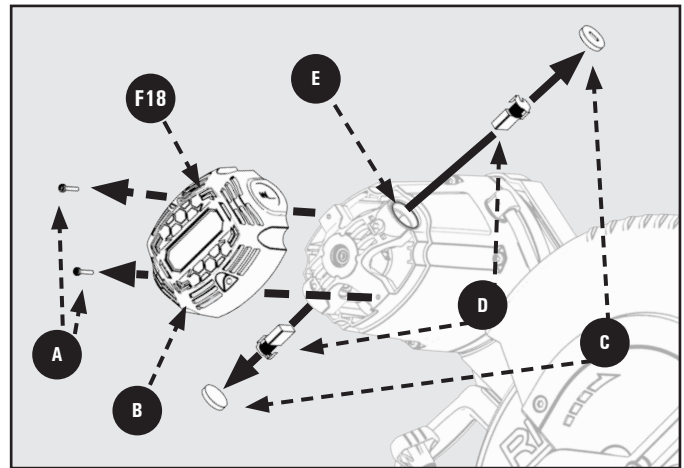

Figure 41

TROUBLESHOOTING

For assistance with your machine, visit our website at www.RIDGID.com for a list of service centers or call RIDGID® Customer Service at (toll free) 1-888-359-4778 or email at RidgidMiterSaws@ridgidproducts.com.

FAILURE TO START

If your machine fails to start, check to make sure the prongs on the cord plug are making good contact in the receptacle, and check reset button on GFCI - Ground Fault Circuit Interrupt (If applicable). Also, check for blown fuses or open circuit breakers in your power line.

Problem	Possible Cause	Solution
Saw will not start	<ol style="list-style-type: none"> 1. Saw un-plugged. 2. Fuse blown or circuit breaker tripped. 3. Damaged power cord. 4. Worn out brushes. 	<ol style="list-style-type: none"> 1. Make sure the saw is plugged in. 2. Replace fuse or reset circuit breaker. 3. Contact local authorized Service Center to have cord replaced. 4. Contact local authorized Service Center to have brushes replaced if you cannot replace them yourself. Refer to page 32.
Saw makes poor cuts	<ol style="list-style-type: none"> 1. Dull saw blade 2. Blade not mounted properly. 3. Residue on pitch or blade. 4. Incorrect type of blade installed. 	<ol style="list-style-type: none"> 1. Replace blade. Refer to page 14. 2. Correct blade fitment. Refer to page 14. 3. Remove and clean the blade. 4. Change the blade. Refer to page 14.
Blade not getting up to speed	<ol style="list-style-type: none"> 1. Extension cord too small gauge or too long. 2. Low current rating from the source. 	<ol style="list-style-type: none"> 1. Replace with correct cord size. Refer to page 10. 2. Contact your electric company.
Machine has excessive vibration	<ol style="list-style-type: none"> 1. Saw is not mounted securely to stand or workbench. 2. Miter saw stand or workbench on uneven floor. 3. Damaged saw blade. 	<ol style="list-style-type: none"> 1. Tighten all mounting hardware. Refer to page 21. 2. Reposition on level surface. Refer to page 21. 3. Replace blade. Refer to page 14.
Miter cuts are not accurate	<ol style="list-style-type: none"> 1. Miter scale not reading correctly. 2. Blade is not square to fence. 3. Blade is not perpendicular to table. 4. Workpiece could be moving during operation. 	<ol style="list-style-type: none"> 1. Check and adjust. Refer to page 16. 2. Check and adjust. Refer to page 16. 3. Check and adjust. Refer to page 15. 4. Clamp workpiece securely to fence.
Material binding in the blade	<ol style="list-style-type: none"> 1. Material could be bowed or could be cutting through knots. 	<ol style="list-style-type: none"> 1. Refer to page 22.

ACCESSORIES

A complete line of accessories is available from your RIDGID® Supplier, RIDGID® Factory Service Centers, and RIDGID® Authorized Service Centers. Please visit our Web Site www.RIDGID.com for an on-line catalog or for the name or your nearest supplier.

⚠ WARNING: Since accessories other than those offered by RIDGID® have not been tested with this product, use of such accessories could be hazardous. For safest operation, only RIDGID® recommended accessories should be used with this product.

PARTS, SERVICE OR WARRANTY ASSISTANCE

RIDGID® STATIONARY POWER TOOL 5 YEAR LIMITED SERVICE WARRANTY

Proof of purchase must be presented when requesting warranty service.

Limited to RIDGID® stationary power tools purchased 2/1/21 and after. This product is manufactured by DPEC. The trademark is licensed from RIDGID®, Inc. All warranty communications should be directed to Customer Service attn: RIDGID® Stationary Power Tool Technical Service at (toll free) 1-888-359-4778.

90-DAY SATISFACTION GUARANTEE POLICY

During the first 90 days after the date of purchase, if you are dissatisfied with the performance of this RIDGID® Stationary Power Tool for any reason you may return the tool to the dealer from which it was purchased for a full refund or exchange. To receive a replacement tool you must present proof of purchase and return all original equipment packaged with the original product. The replacement tool will be covered by the limited warranty for the balance of the 5 YEAR service warranty period.

WHAT IS COVERED UNDER THE 5 YEAR LIMITED SERVICE WARRANTY

This warranty on RIDGID® Stationary Power Tools covers all defects in workmanship or materials in this RIDGID® tool for five years following the purchase date of the tool. Warranties for other RIDGID® products may vary.

HOW TO OBTAIN SERVICE

To obtain service for this RIDGID® tool you must call RIDGID® Customer Service at (toll free) 1-888-359-4778 or email us at RidgidMiterSaws@ridgidproducts.com. When requesting warranty service, you must present the original dated sales receipt. The authorized service center will repair any faulty workmanship, and either repair or replace any part covered under the warranty, at our option, at no charge to you.

WHAT IS NOT COVERED

This warranty applies only to the original purchaser at retail and may not be transferred. This warranty only covers defects arising under normal usage and does not cover any malfunction, failure or defect resulting from misuse, abuse, neglect, alteration, modification or repair by other than an authorized service center for RIDGID® branded stationary power tools. Consumable accessories provided with the tool such as, but not limited to, blades, bits and sand paper are not covered.

RIDGID® MAKE NO WARRANTIES, REPRESENTATIONS OR PROMISES AS TO THE QUALITY OR PERFORMANCE OF ITS POWER TOOLS OTHER THAN THOSE SPECIFICALLY STATED IN THIS WARRANTY.

ADDITIONAL LIMITATIONS

To the extent permitted by applicable law, all implied warranties, including warranties of MERCHANTABILITY or FITNESS FOR A PARTICULAR PURPOSE, are disclaimed. Any implied warranties, including warranties of merchantability or fitness for a particular purpose, that cannot be disclaimed under state law are limited to five years from the date of purchase. RIDGID® is not responsible for direct, indirect, incidental or consequential damages. Some states do not allow limitations on how long an implied warranty lasts and/or do not allow the exclusion or limitation of incidental or consequential damages, so the above limitations may not apply to you. This warranty gives you specific legal rights, and you may also have other rights which vary from state to state.

DPEC

2651 New Cut Road
Spartanburg, SC 29303

NOTES

OPERATOR'S MANUAL

10 inch Sliding Compound Miter Saw

R4241

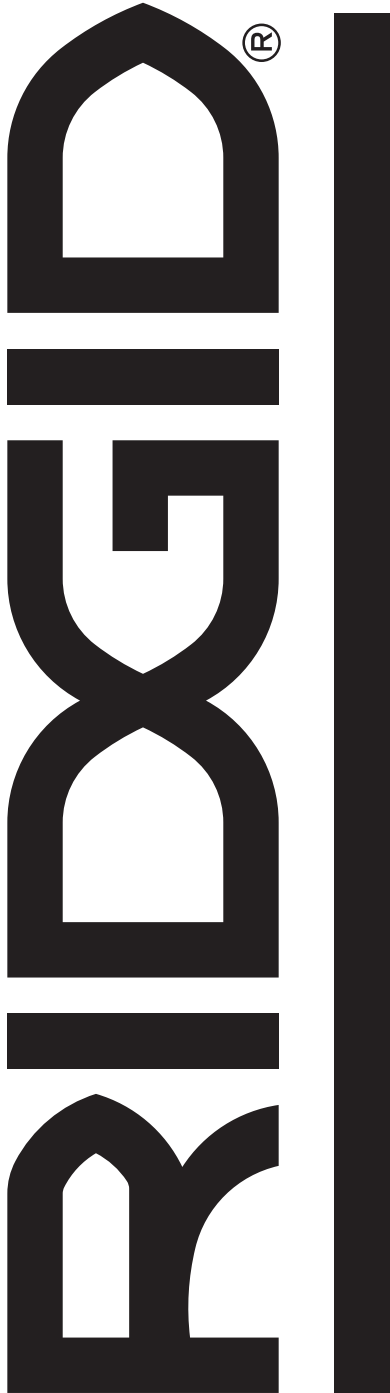

Customer Service Information:

For parts or service, do not return this product to the store. Contact your nearest RIDGID® authorized service center. Be sure to provide all relevant information when you call or visit. For the location of the authorized service center nearest you, please call 1-888-359-4778 or email us at RidgidMiterSaws@ridgidproducts.com.

MODEL NO.* _____ SERIAL NO. _____

**Model number on product may have additional letters at the end. These letters designate manufacturing information and should be provided when calling for service.*

DPEC

2651 New Cut Road
Spartanburg, SC 29203
©2021