

Package Contents (continued)

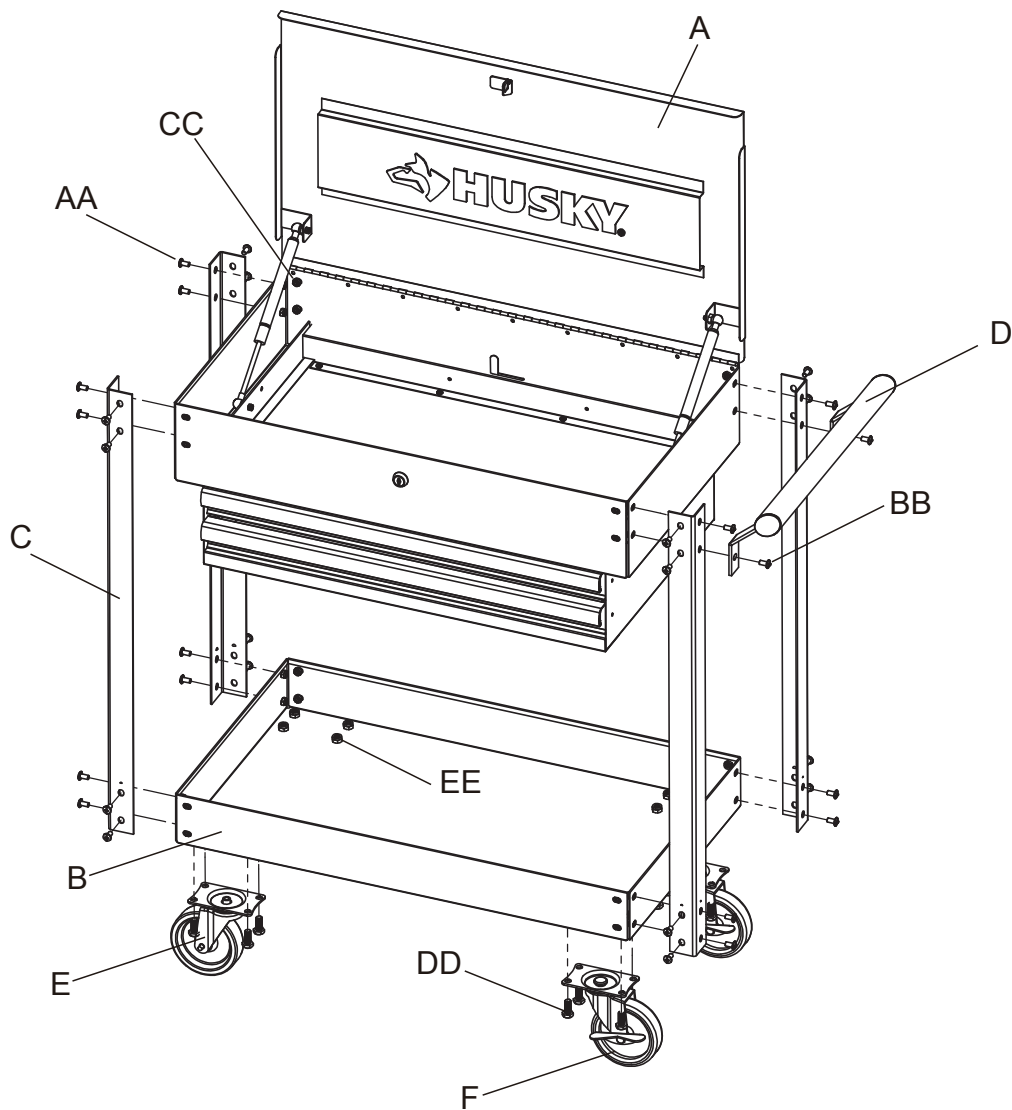

NOTE: The keys are taped to the top of the caster box, which is inside drawer body.



Part	Description	Quantity
A	Drawer body	1
B	Bottom tray	1
C	Upright support	4
D	Side handle	1
E	Swivel caster without brake	2
F	Swivel caster with brake	2

Tools Required

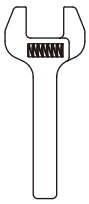

Adjustable Wrench



Slotted or Phillips Screwdriver

Package Contents

HARDWARE INCLUDED



NOTE: Hardware not shown to actual size.



AA



BB



CC



DD



EE

Part	Description	Quantity
AA	M6x12 bolt	30
BB	M6x16 bolt	2
CC	M6 nut	32
DD	M8x16 bolt	16
EE	M8 nut	16

Assembly

1 Attaching upright supports to bottom tray and drawer body and side handle

- Attach upright supports (C) to bottom tray (B), using 4 sets of bolts (AA) and nuts (CC) for each upright supports.
- Attach drawer body (A) on other end of upright supports (C) using 4 sets of bolts (AA) and nuts (CC), but install side handle (D) at the same time on preferred side by inserting bolts (BB) through side handle (D), upright supports (C) and drawer body (A) and tighten with nuts (CC).
- Square up unit and tighten securely. See assembly diagram.

2 Attaching the casters

- Be sure the drawers are locked and lay the cart on its top. Use packaging material to protect the finish.
- Attach the swivel brake plastic casters (F) to the unit, on the same side as the handle, inserting bolts (DD) through bottom tray (B).
- Tighten securely with nuts (EE).
- Repeat this process for the swivel casters without brake (E) on the opposite side of the cart.
- Return the cart to its upright position.