

INSTA•RAIL

Assembly Instruction

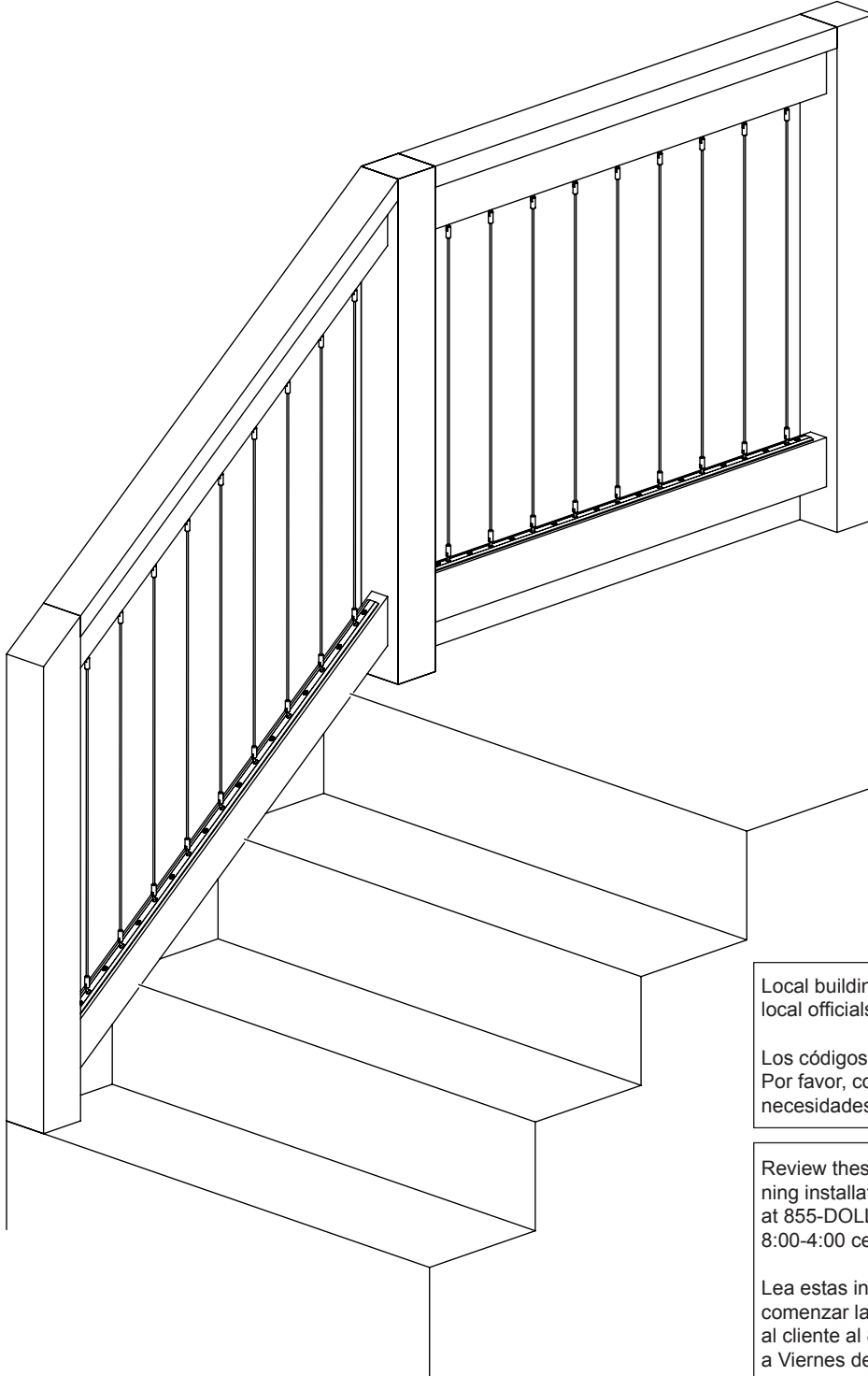

Local building codes vary. Please consult with your local officials for specific requirements.

Los códigos de construcción locales pueden variar. Por favor, consulte con su funcionarios locales para necesidades específicas.

Review these instructions completely before beginning installation. Questions – call customer service at 855-DOLLEUS or 763-452-7483 – Monday-Friday 8:00-4:00 central time.

Lea estas instrucciones en su totalidad antes de comenzar la instalación. Preguntas, llame a servicio al cliente al 855-DOLLEUS o 763-452-7483 – Lunes a Viernes de 8:00-4:00 hora central.

Please note that even stainless steel can show signs of rust if placed in or near aggressive environmental surroundings such as close to salt water. By applying a wax coating – from i.e. auto shampoo with wax content helps protecting the surface from rust. Loose rust can easily be removed using a metal cleaner

Por favor, tenga en cuenta que el acero inoxidable, incluso puede mostrar signos de moho si se colocan en o cerca de un entorno ambiental agresivas tales como cerca de agua salada. Mediante la aplicación de una capa de cera - es decir, desde el champú de auto con contenido de cera ayuda a proteger la superficie contra la oxidación. Óxido suelto se puede quitar fácilmente usando un limpiador de metales.

Part List – Lista de artículos

Component & Number of Each Component

Please check that all items are included before assembly.

Componente & el número de cada uno de los componentes

Por favor compruebe que se incluyen todos los elementos antes del montaje.

10



× 36
K1-90631

11

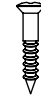

× 40
K3-06300

12



× 1 (Only for 36")
K1-90699

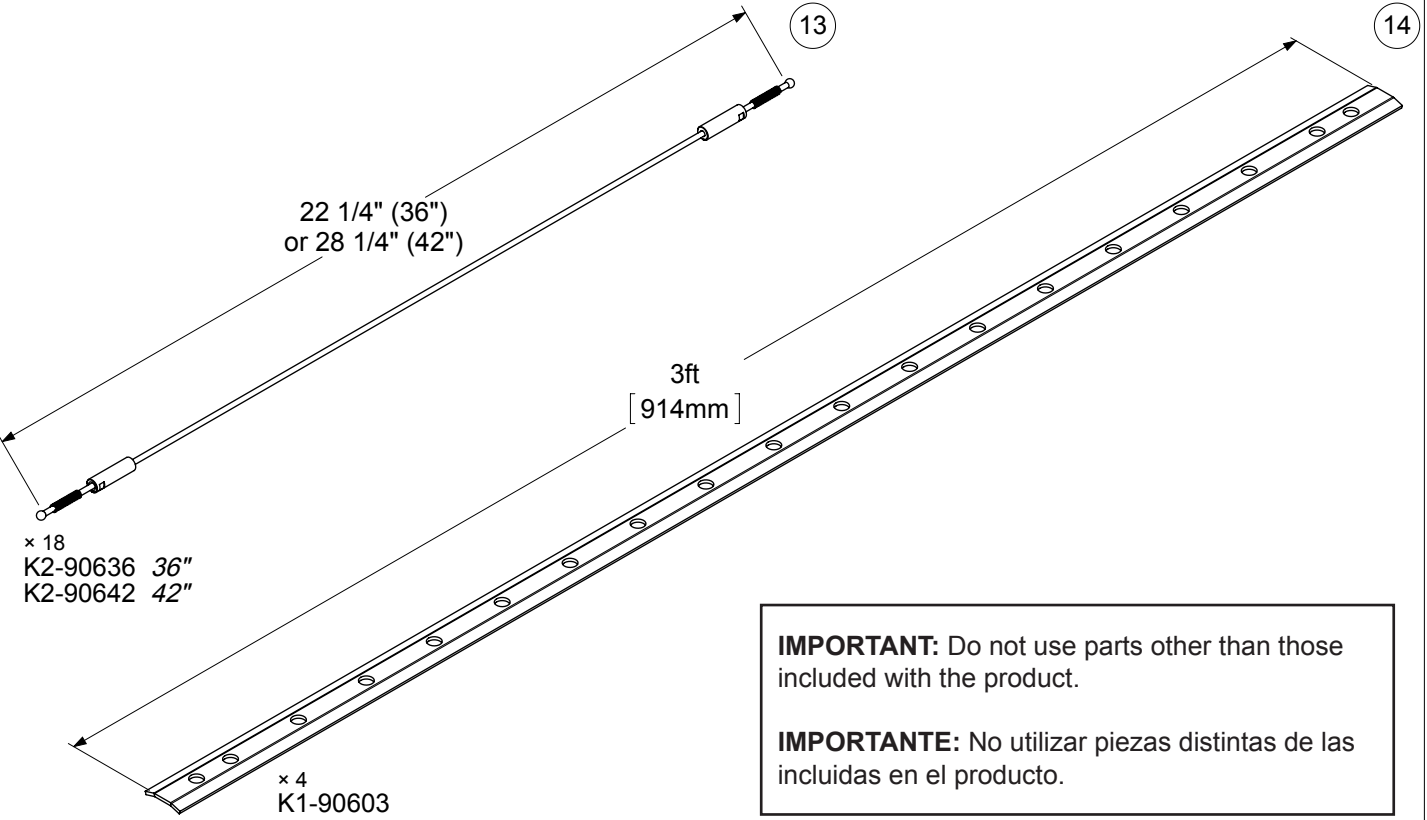

IMPORTANT: Do not use parts other than those included with the product.

IMPORTANTE: No utilizar piezas distintas de las incluidas en el producto.

Tools Required – NOT Supplied
Herramientas necesarias - No incluido

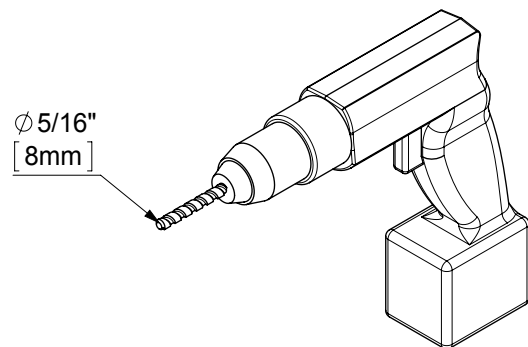
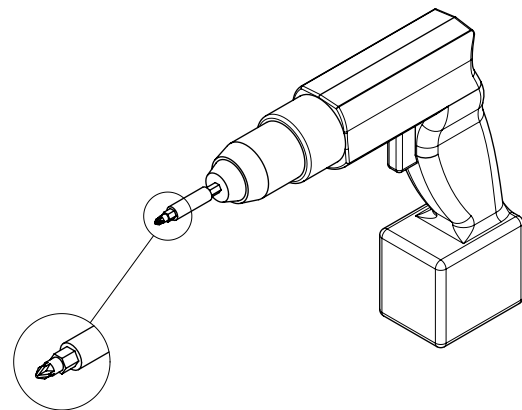
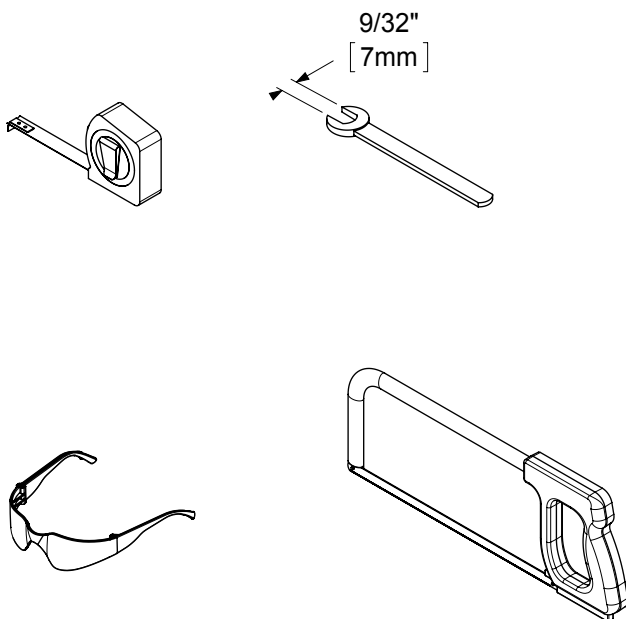

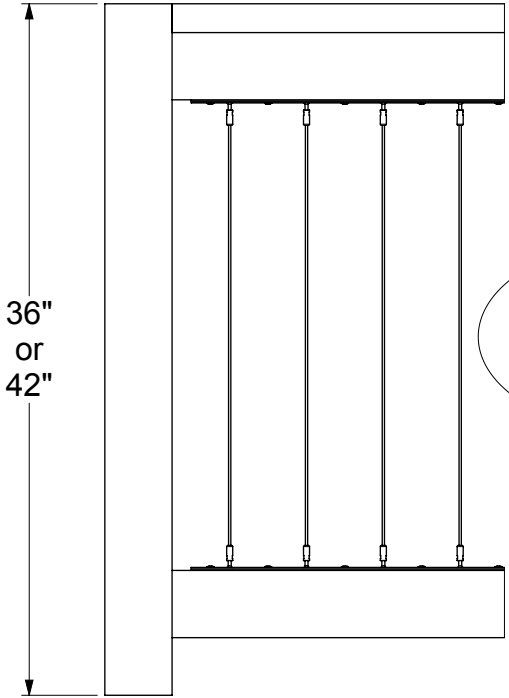

24 1/2"
or
30 1/2" } + 1/16"
- 3/32"

Ideal dimensions
Dimensiones ideales

If more than
Si más de

If less than
Si menos de

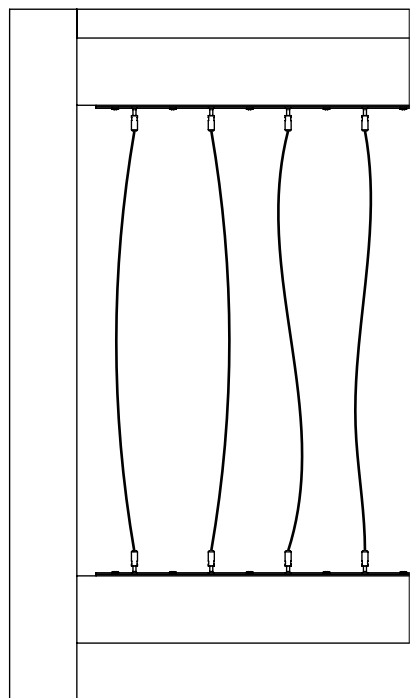
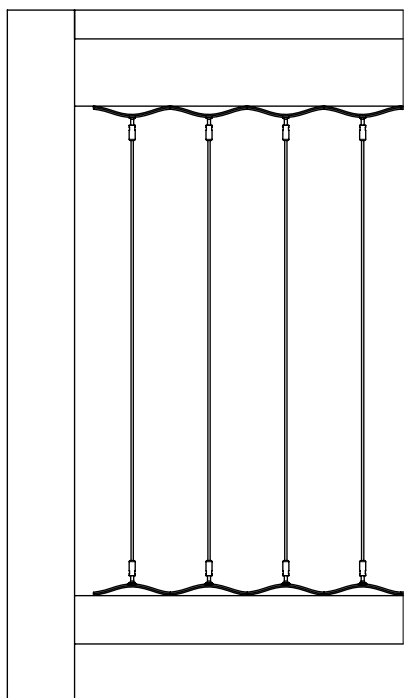

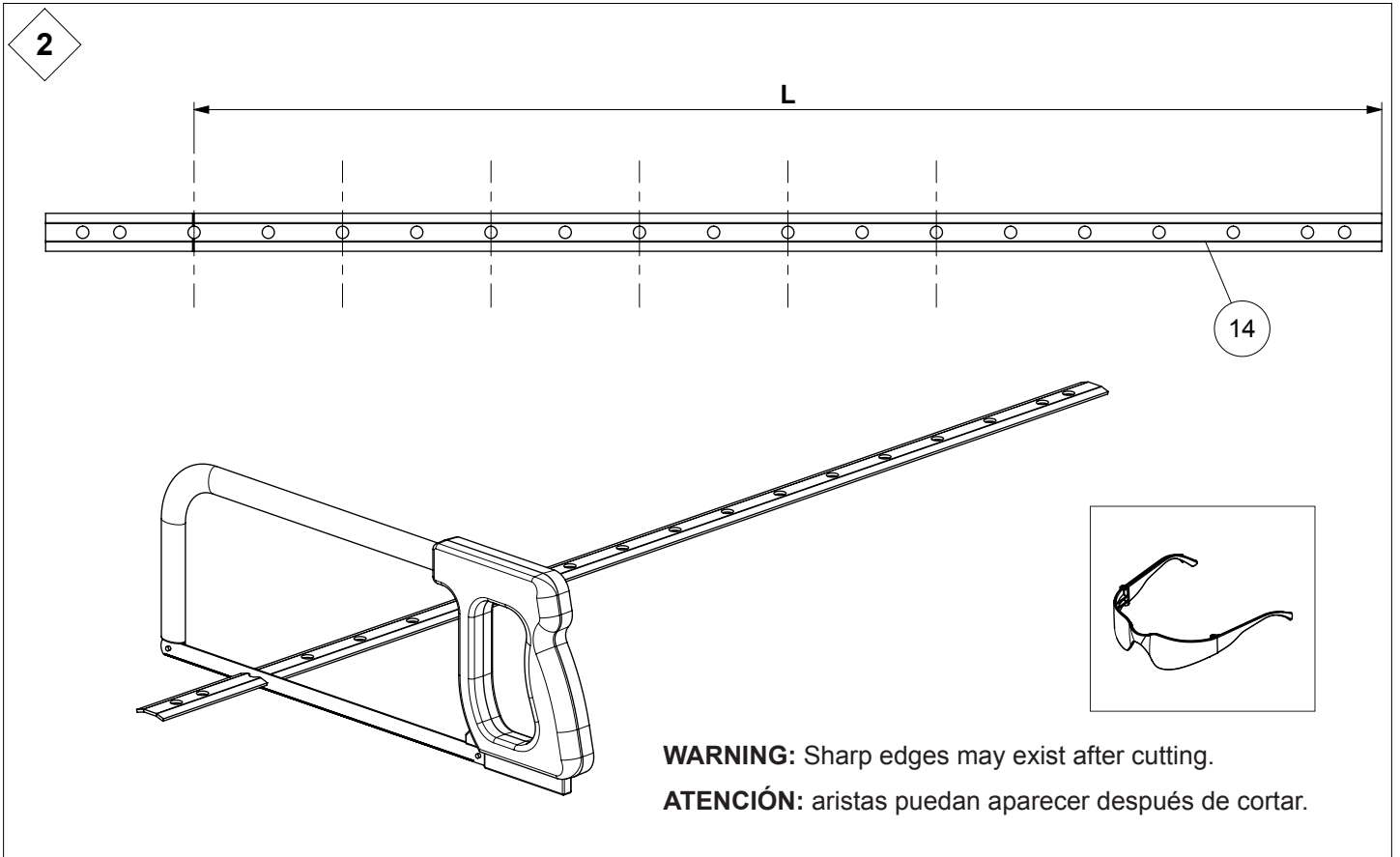
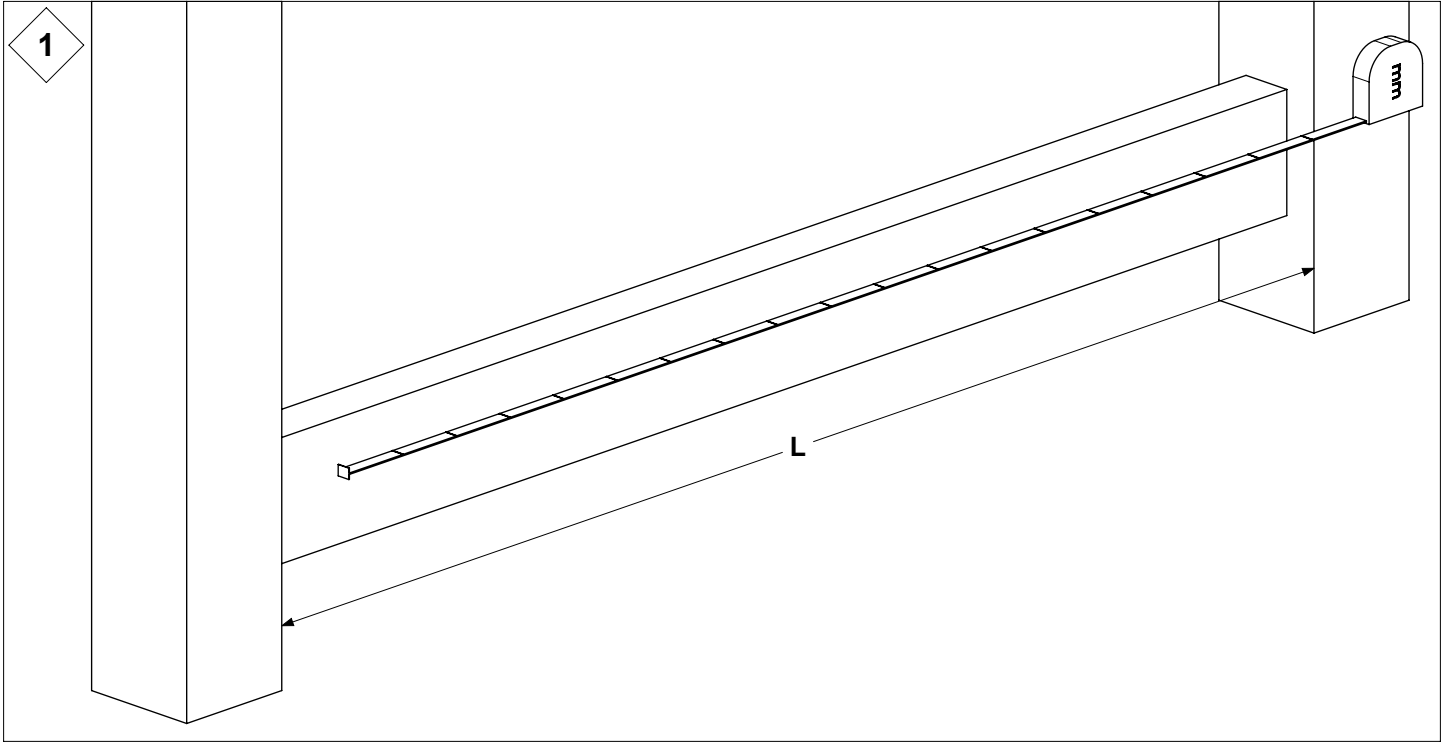
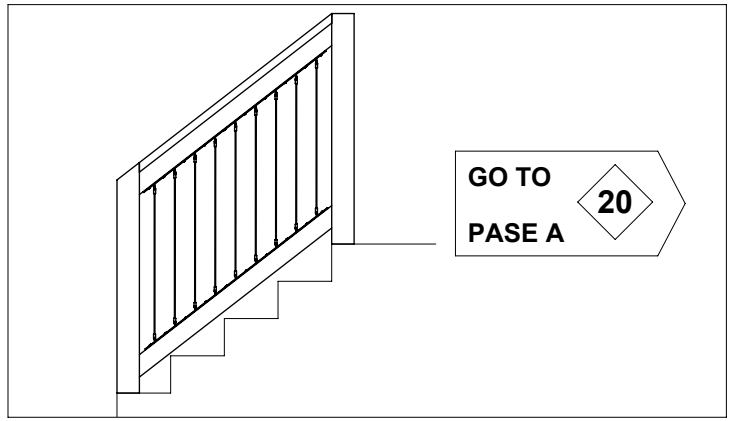
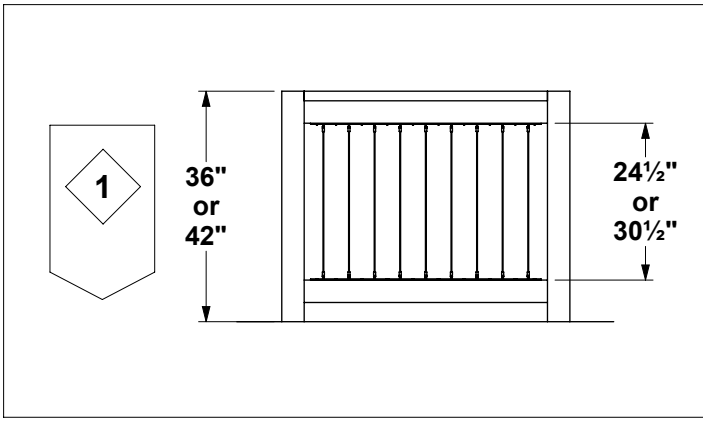

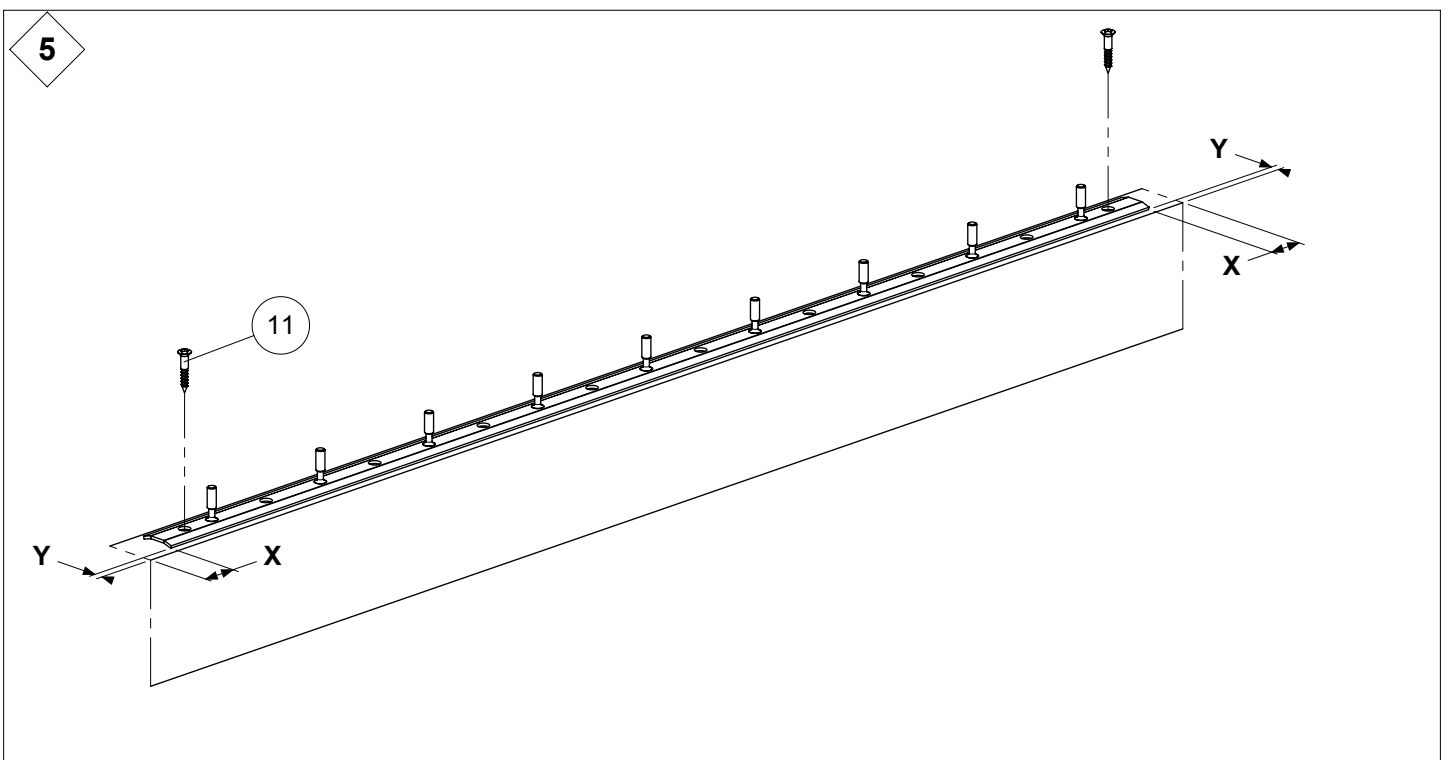
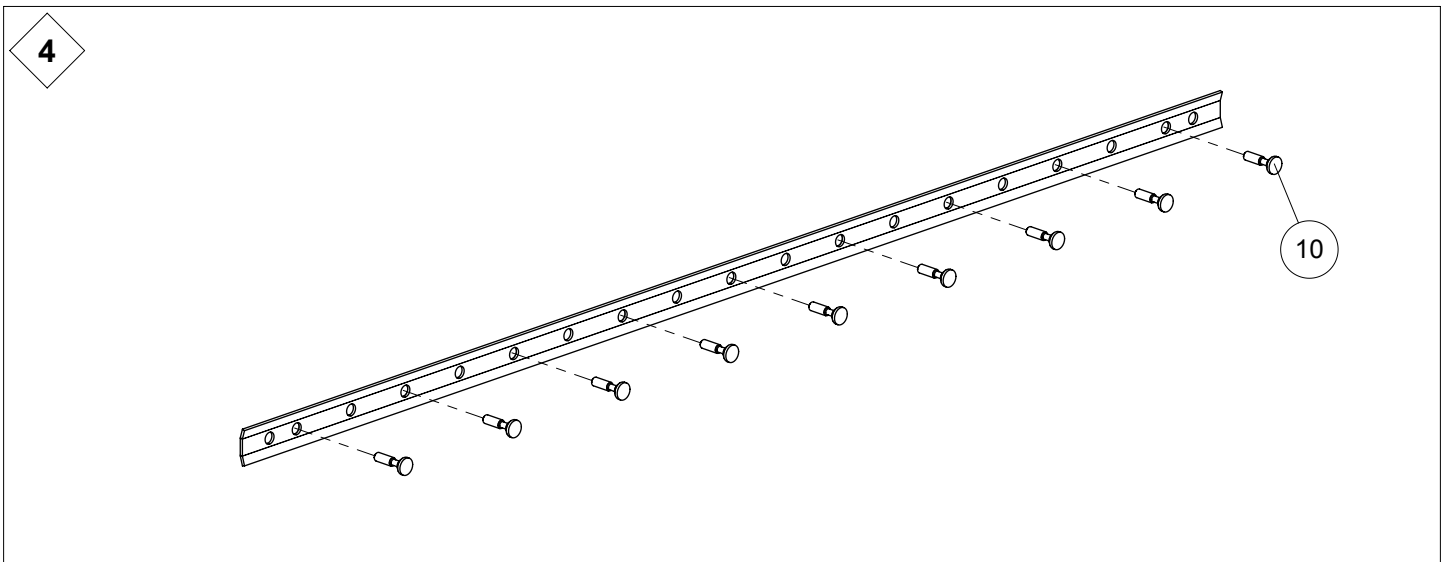
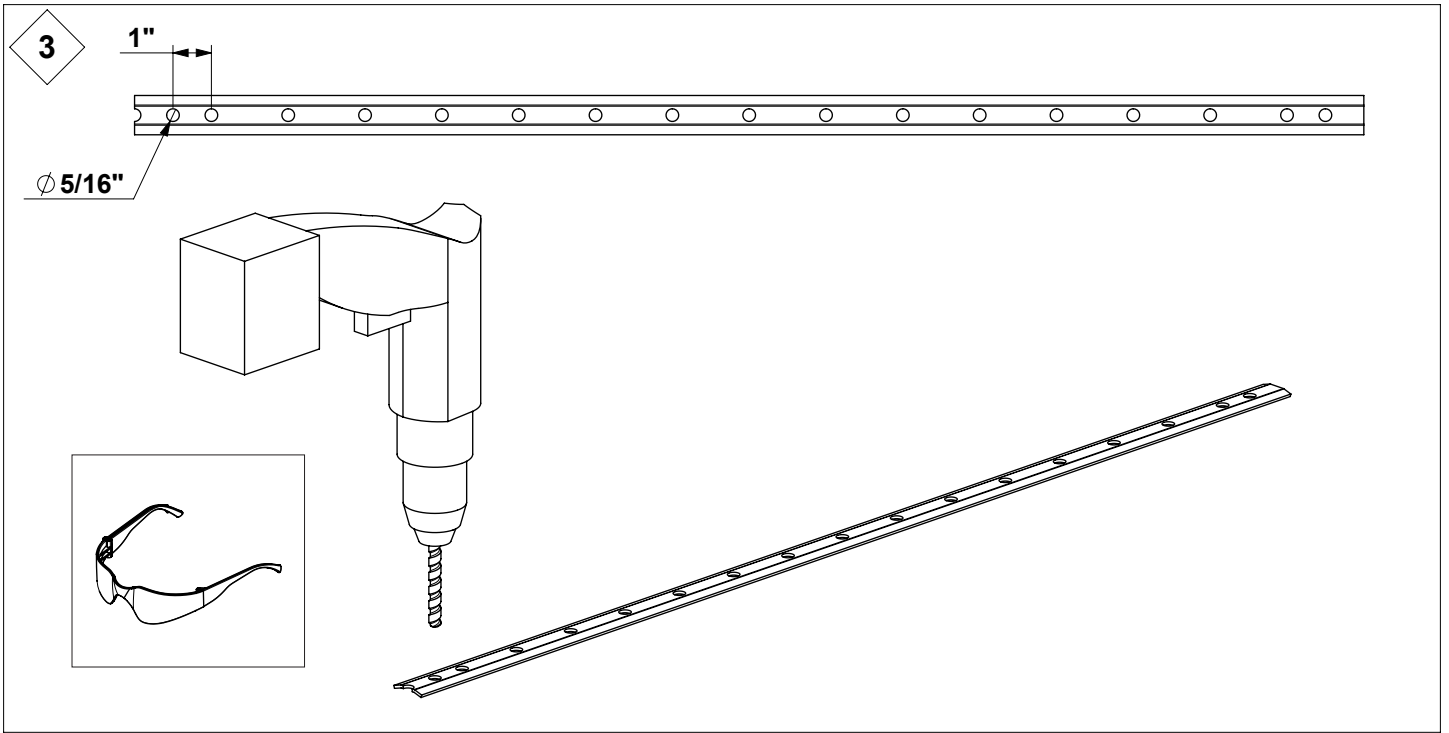

6

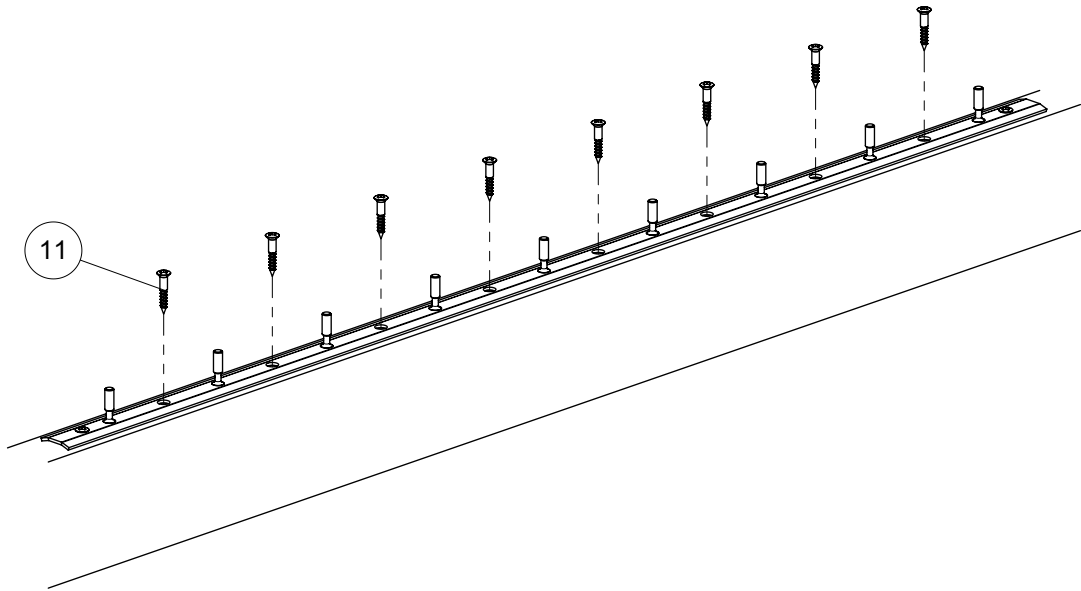

Do not over tighten wood screws – tracks should not be deformed.

No se aprete demasiado los tornillos para la madera – las pistas no deben deformarse.

7

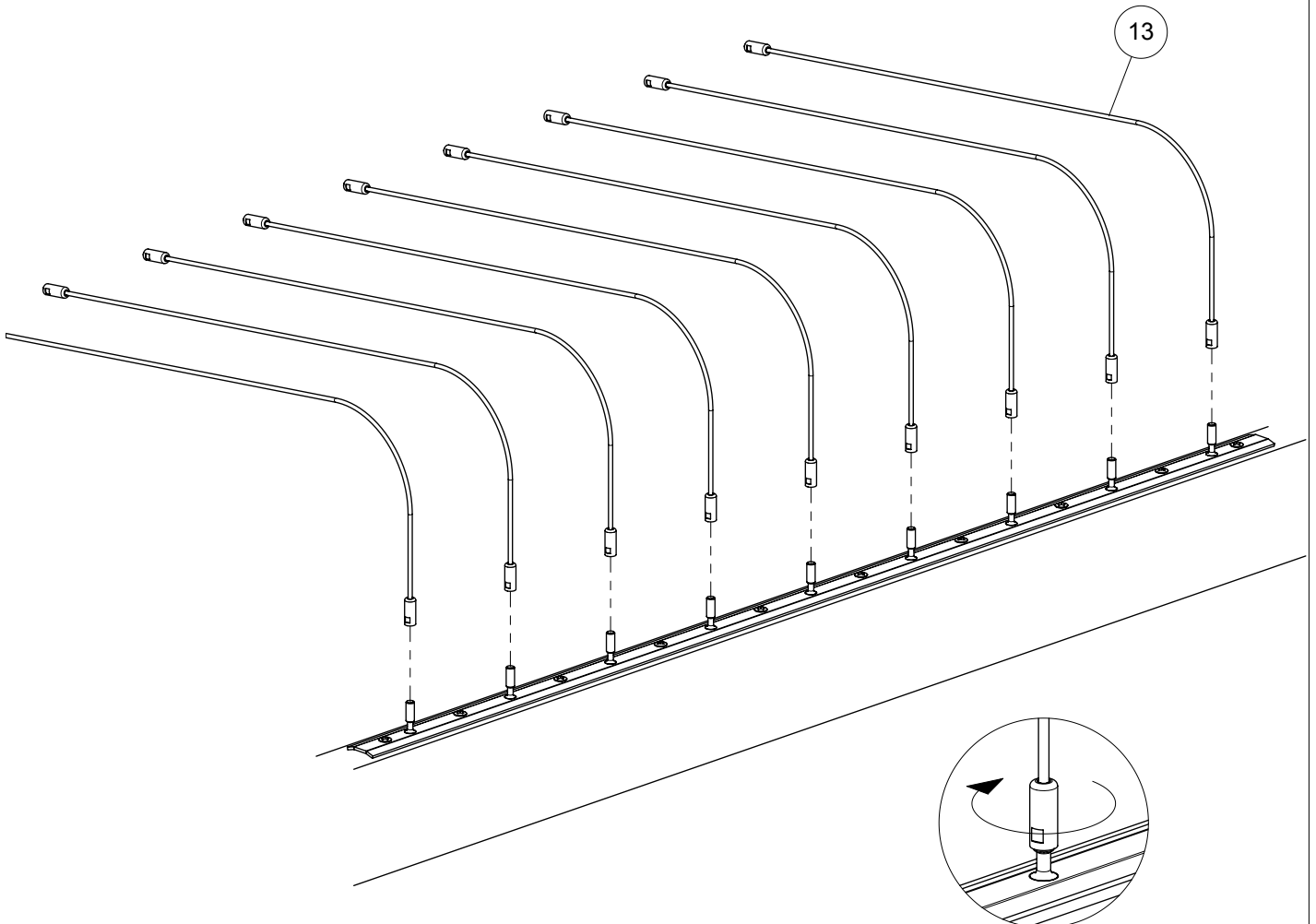

8

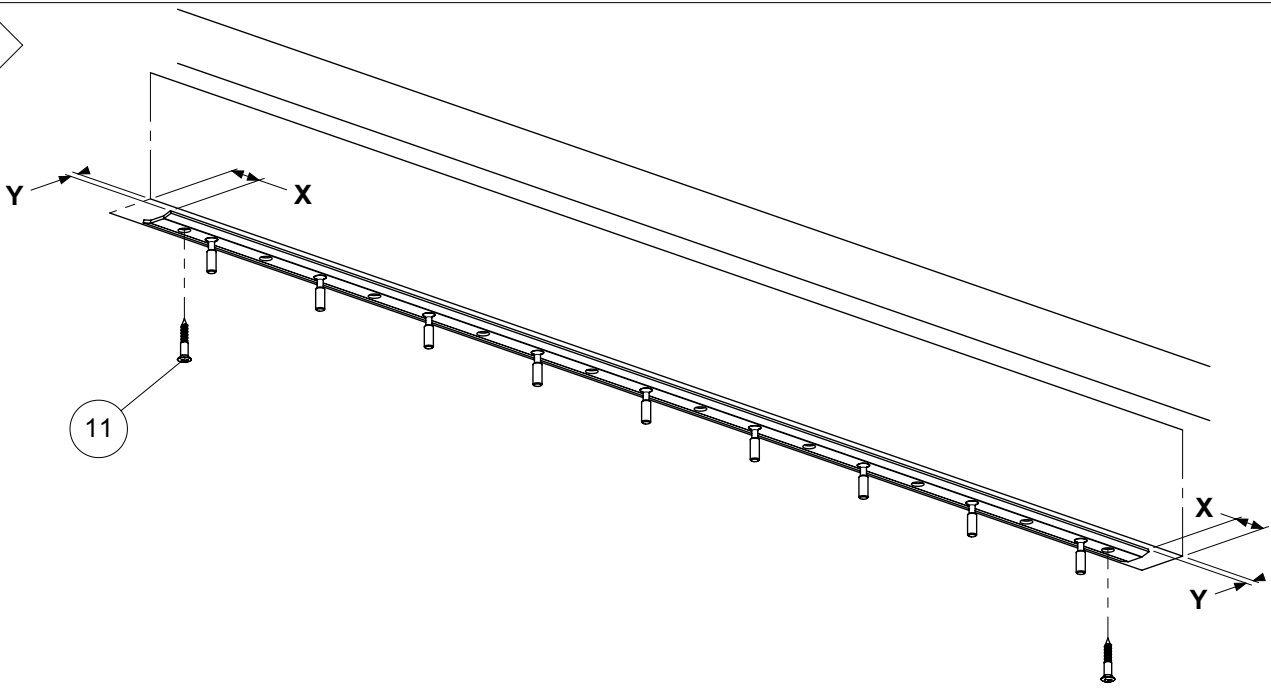

9

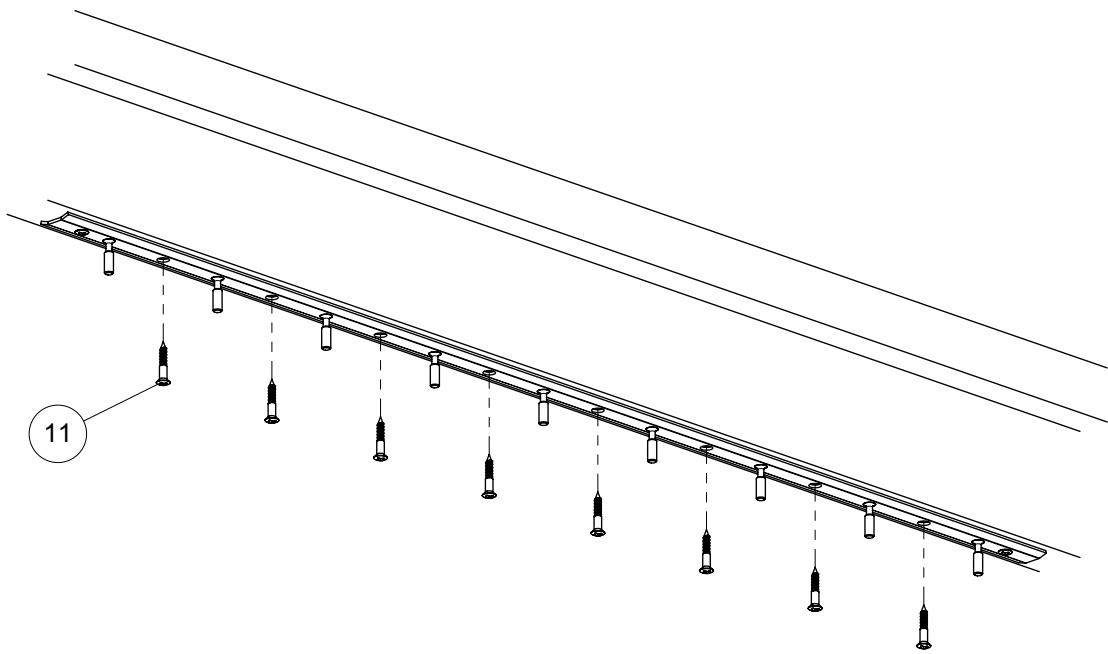

10

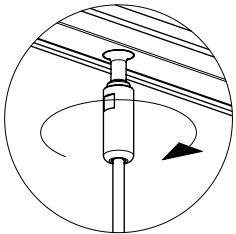

Hold stud with pliers.
Do not overtighten with
excessive force.

Sostenga el clavo con
una pinza. No apriete
de sobra usando fuerza
excesiva.

13

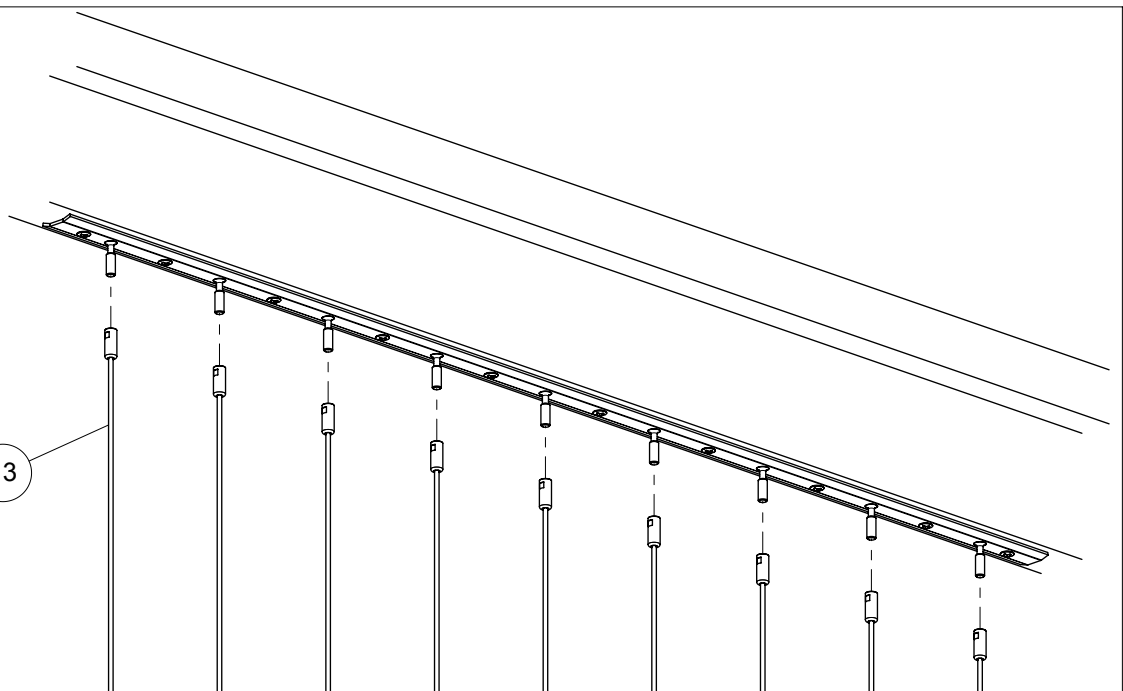

11

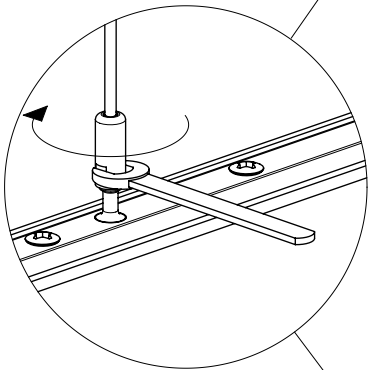

Hold stud with pliers.
Do not overtighten with
excessive force.

Sostenga el clavo con
una pinza. No apriete
de sobra usando fuerza
excesiva.

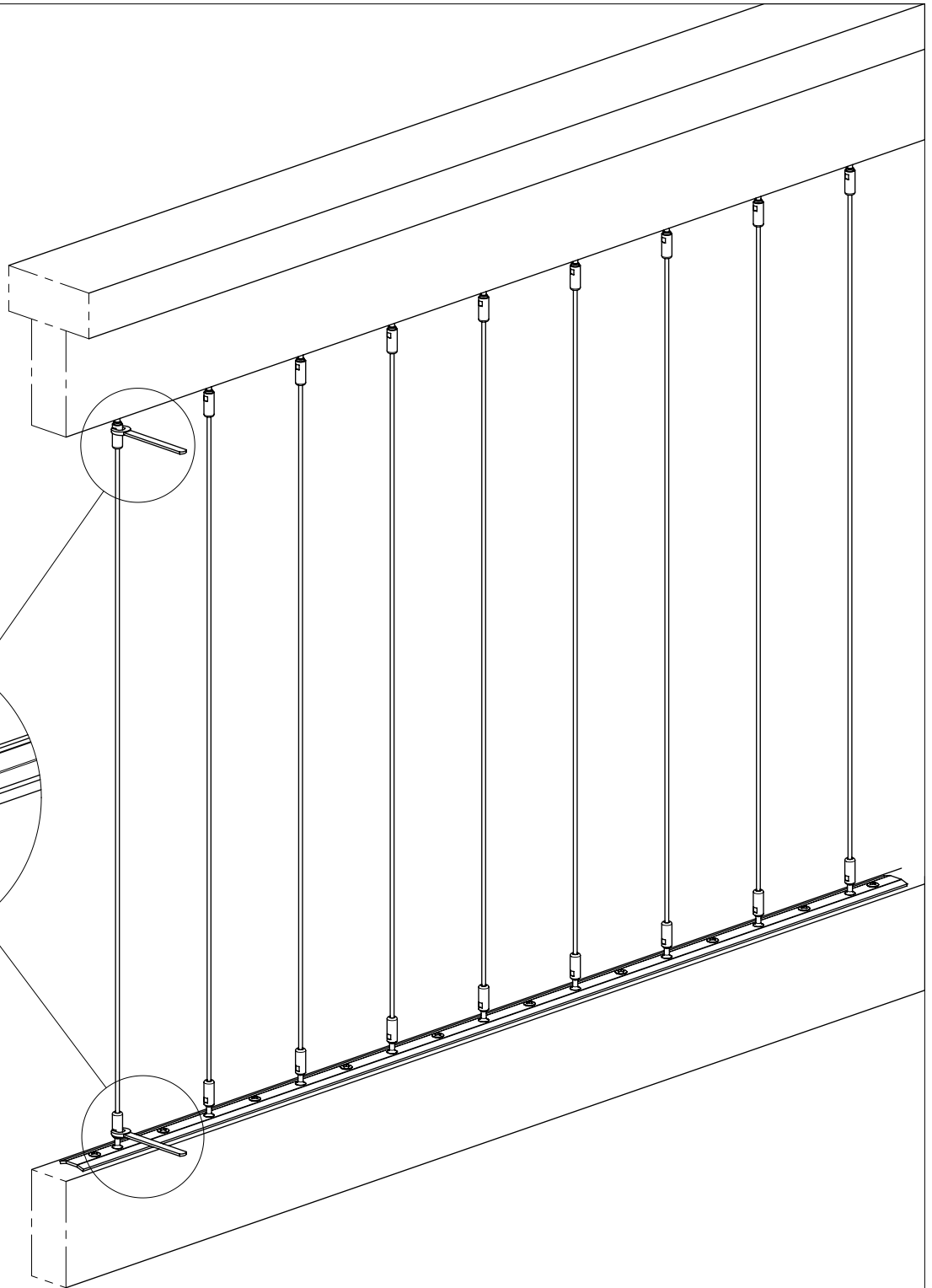

11

PLEASE NOTE

TENGA EN CUENTA

20

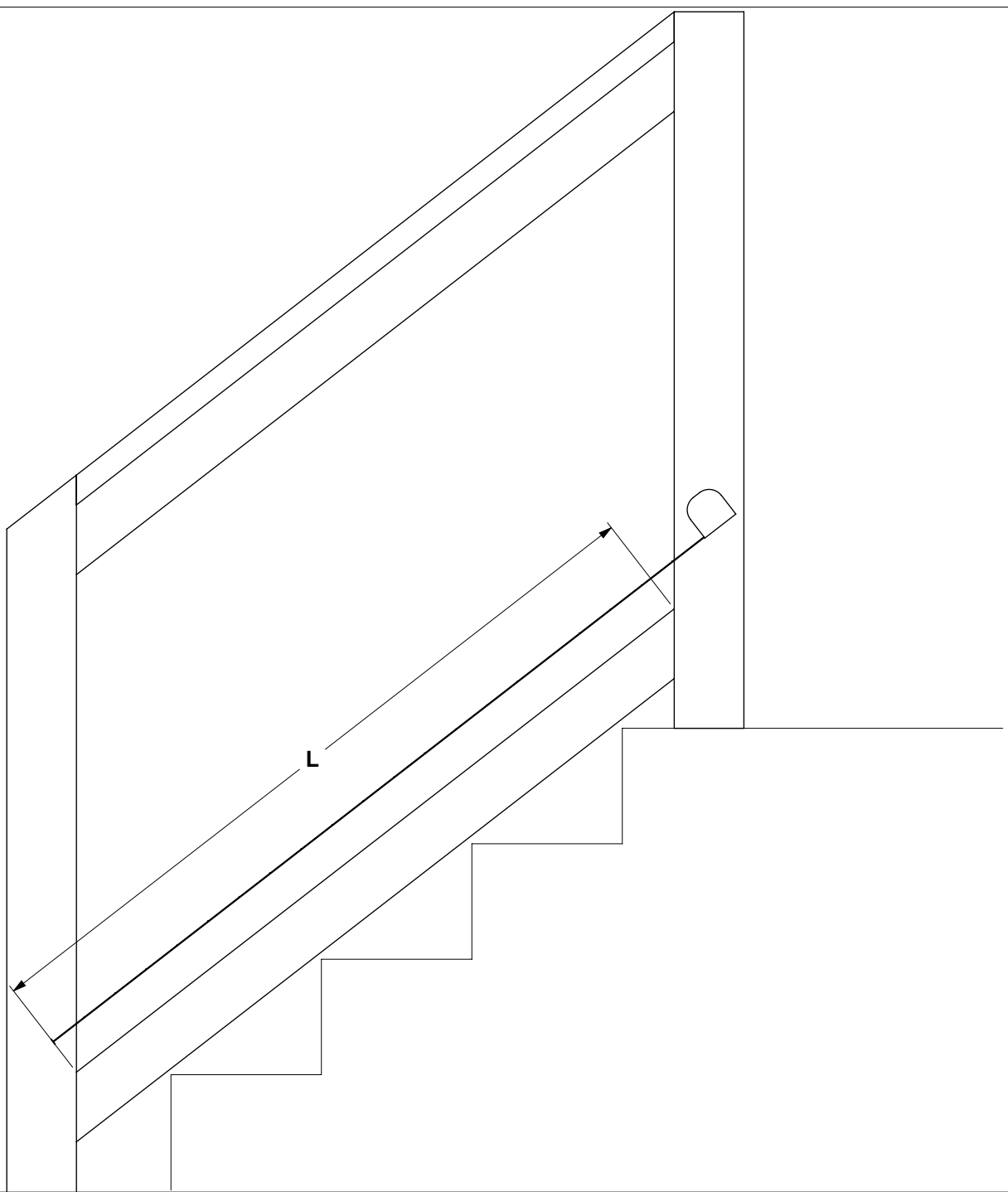

21

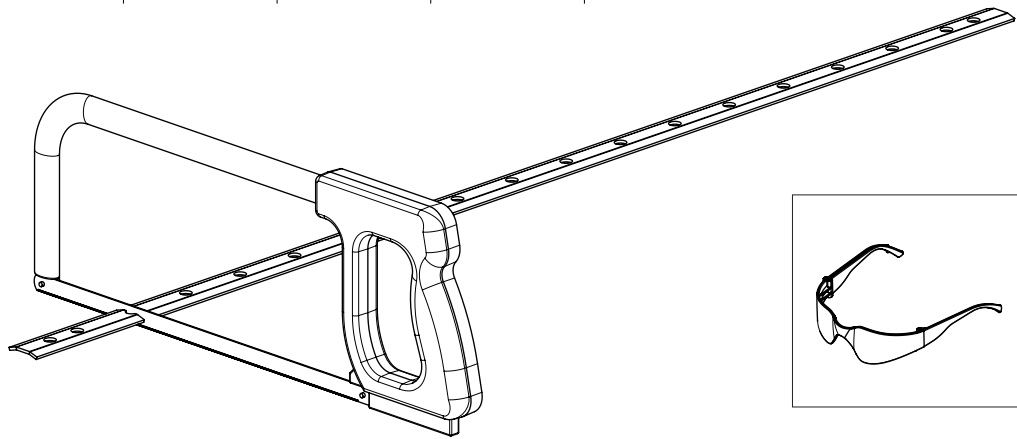
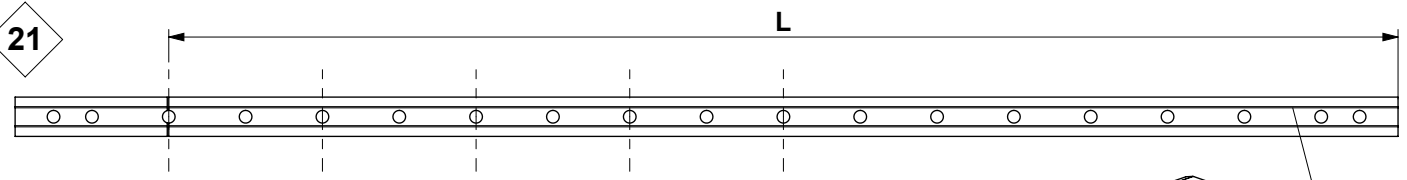

14

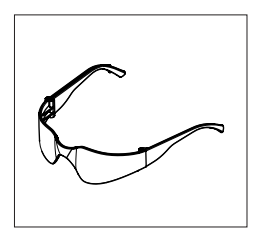

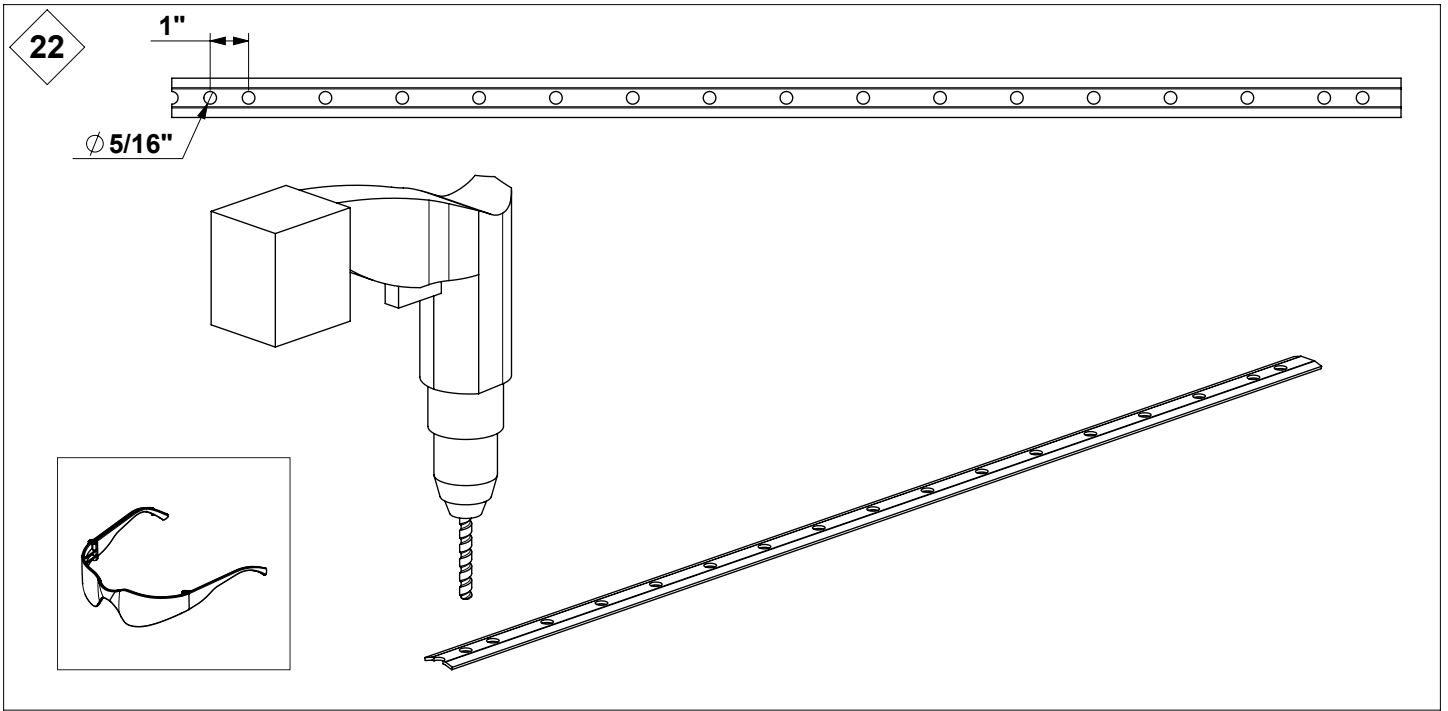

Pre bend the first cable tension fitting prior to installing complete (reference $\diamond 28$)
 Pretorcer el primer herraje de tensión de cables antes de instalar completamente (referencia $\diamond 28$)

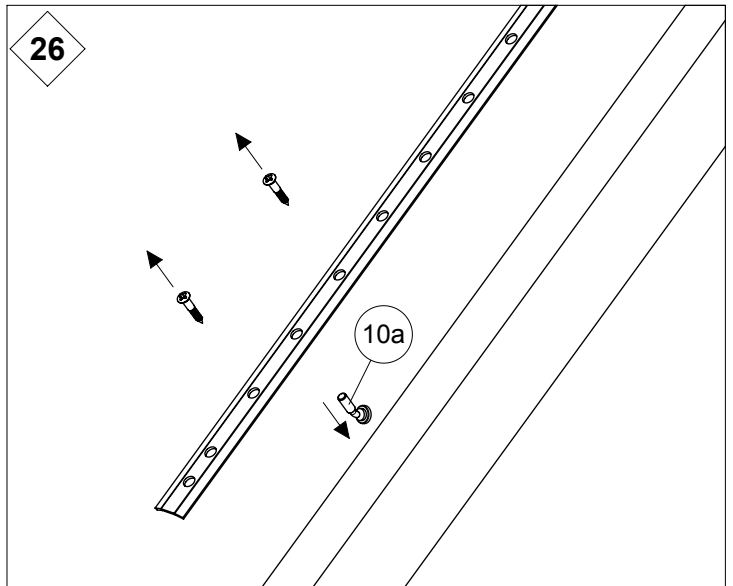
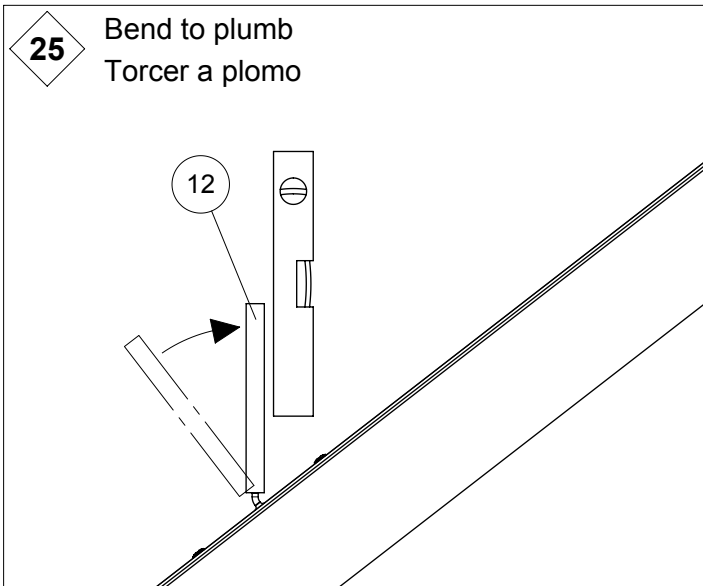
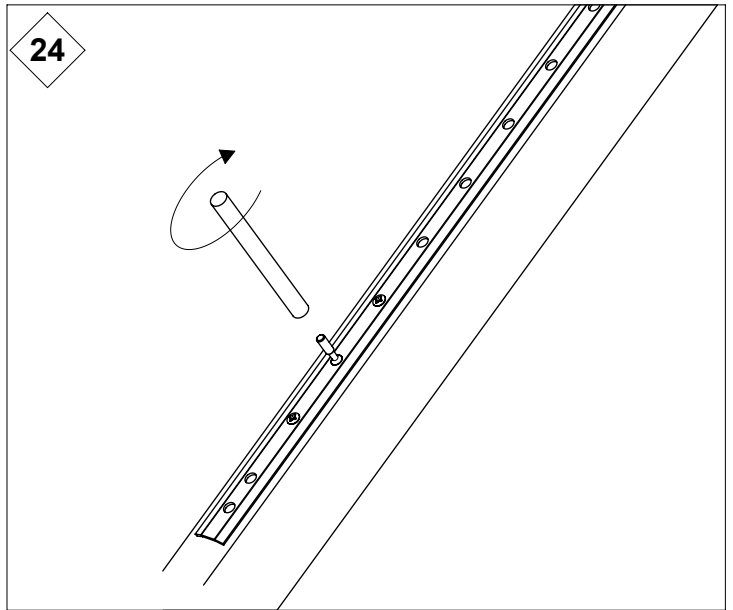
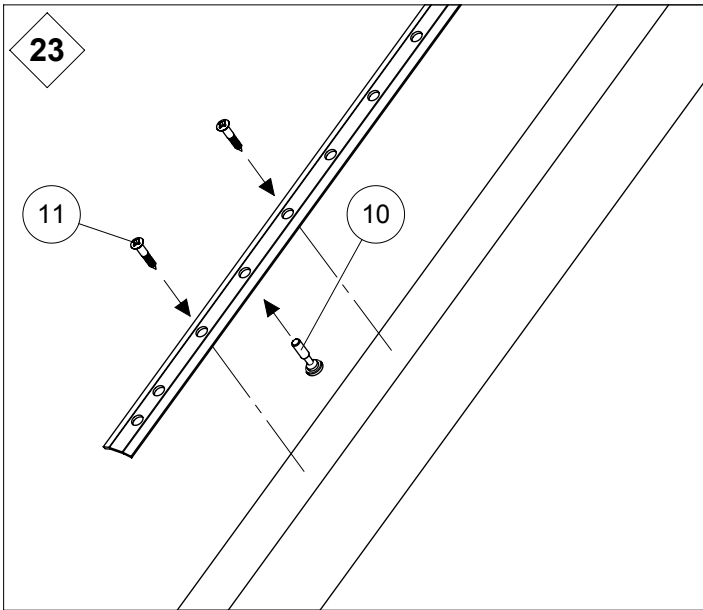

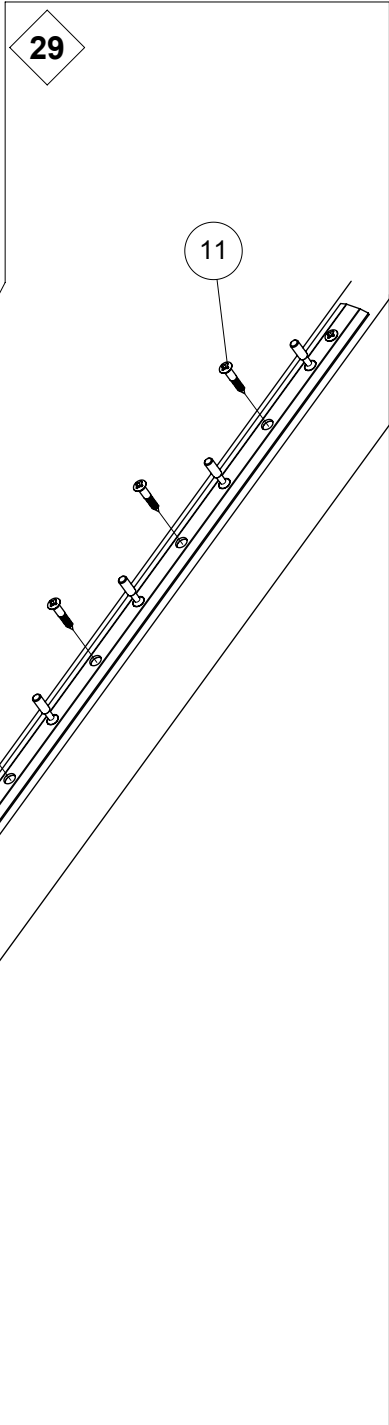
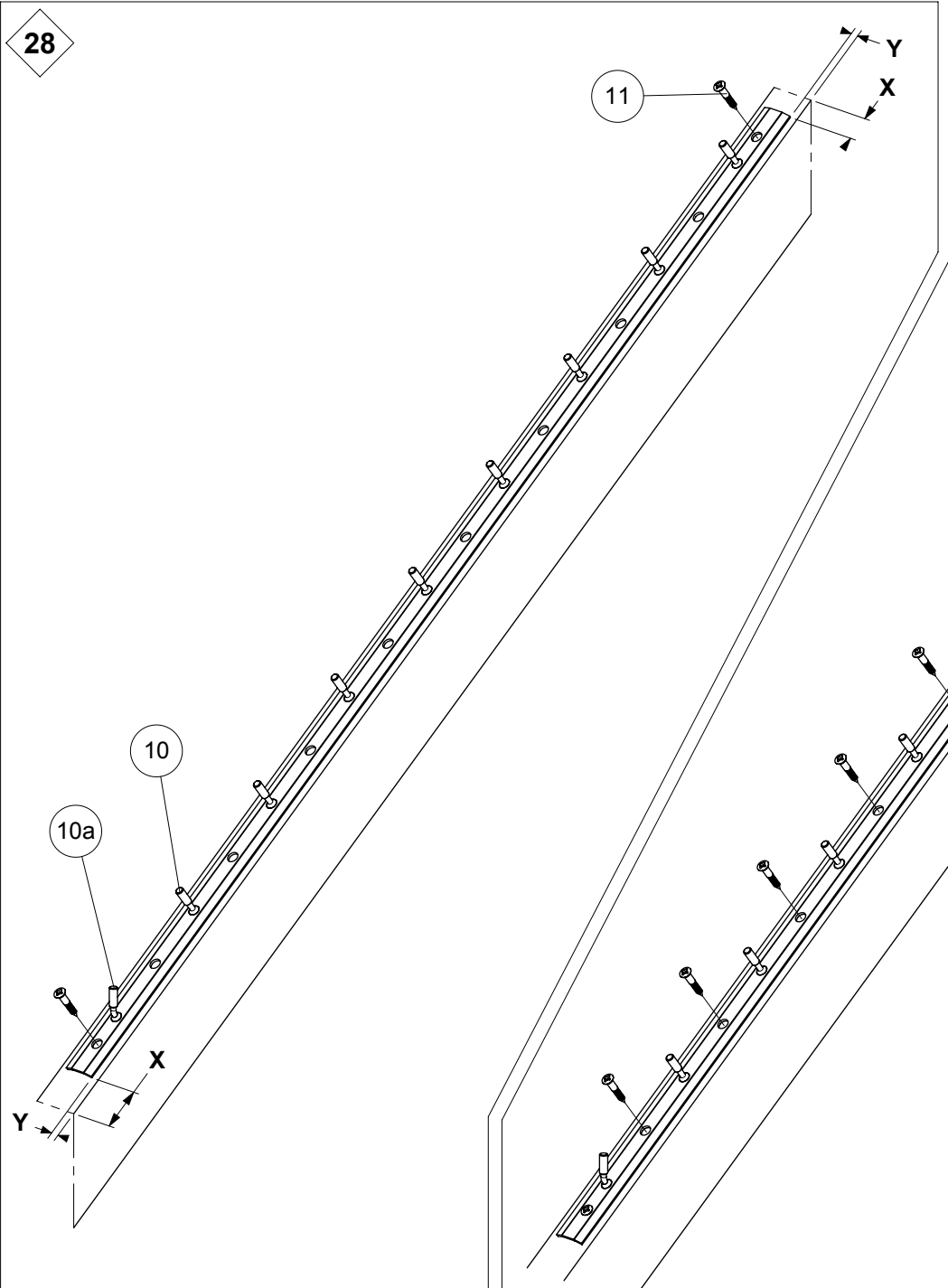
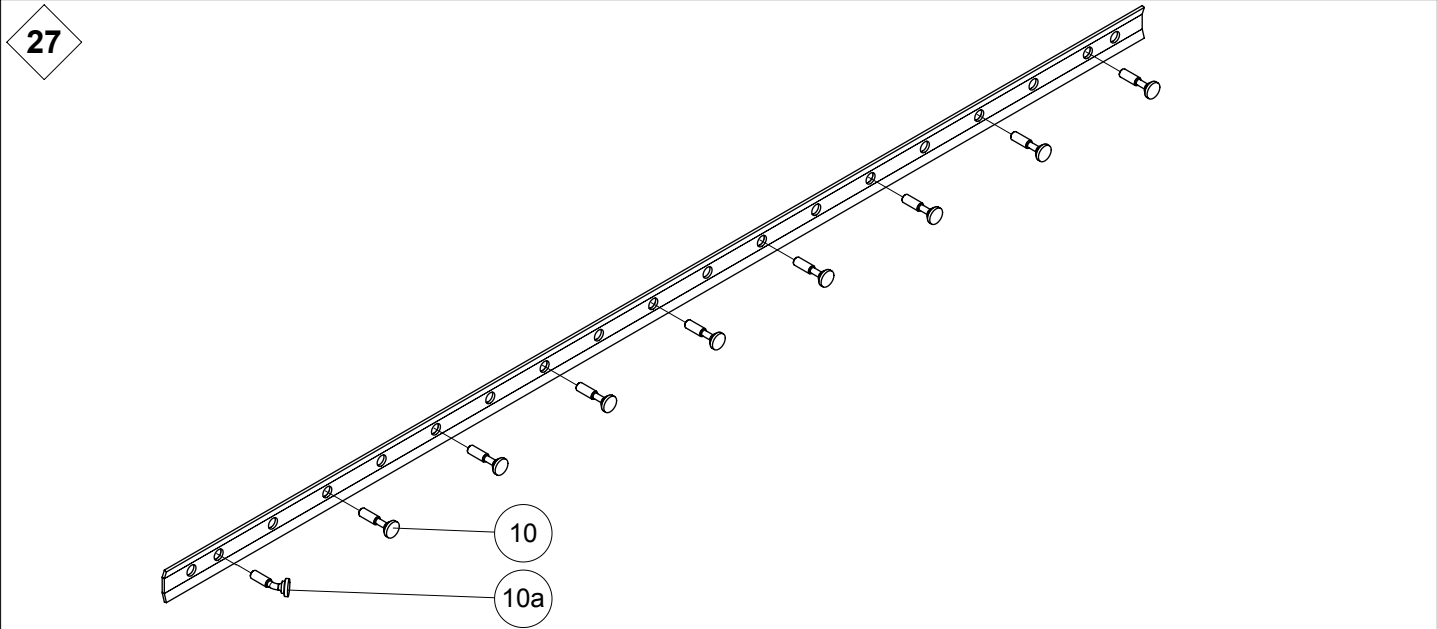

30

12

31

13

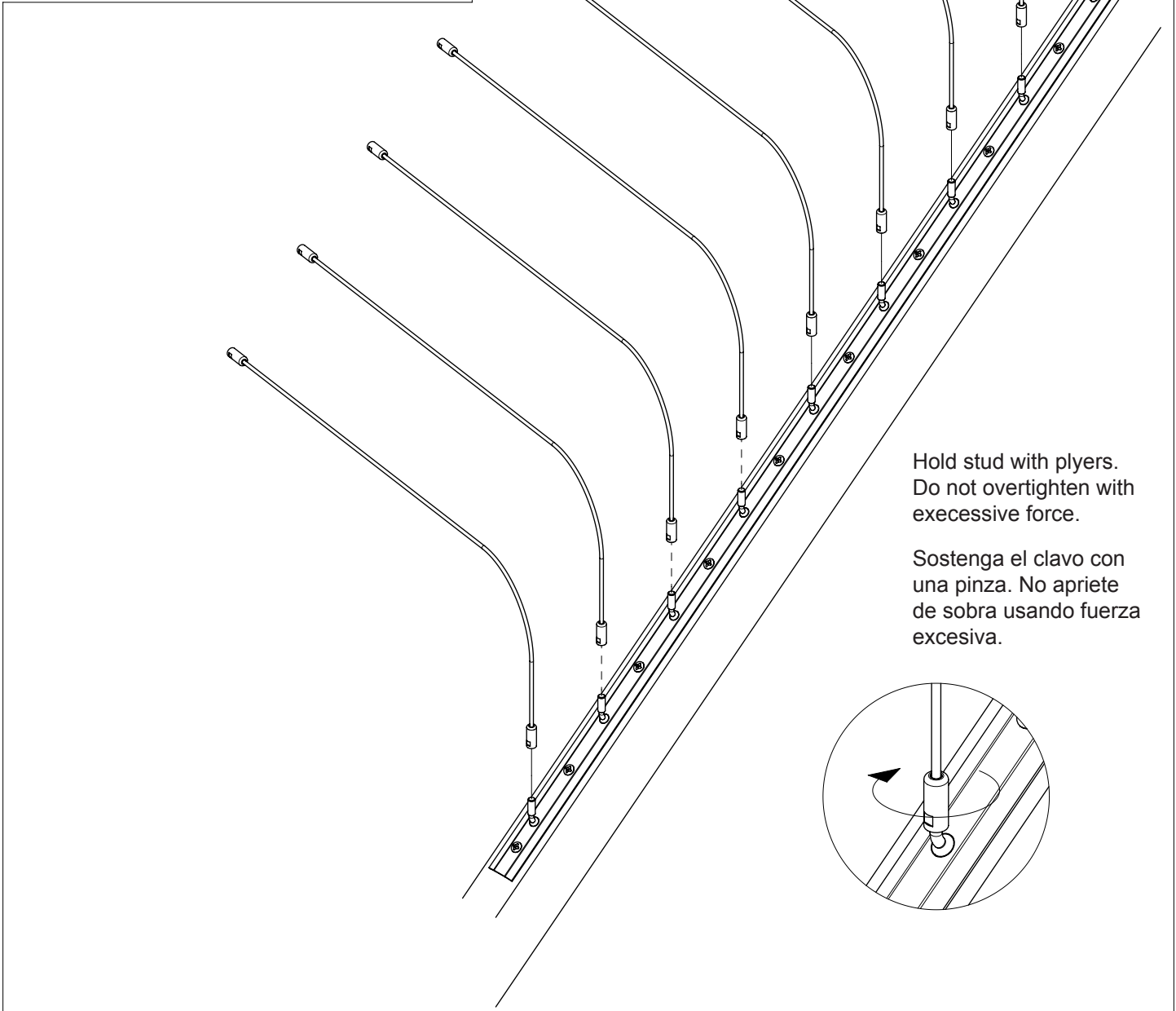
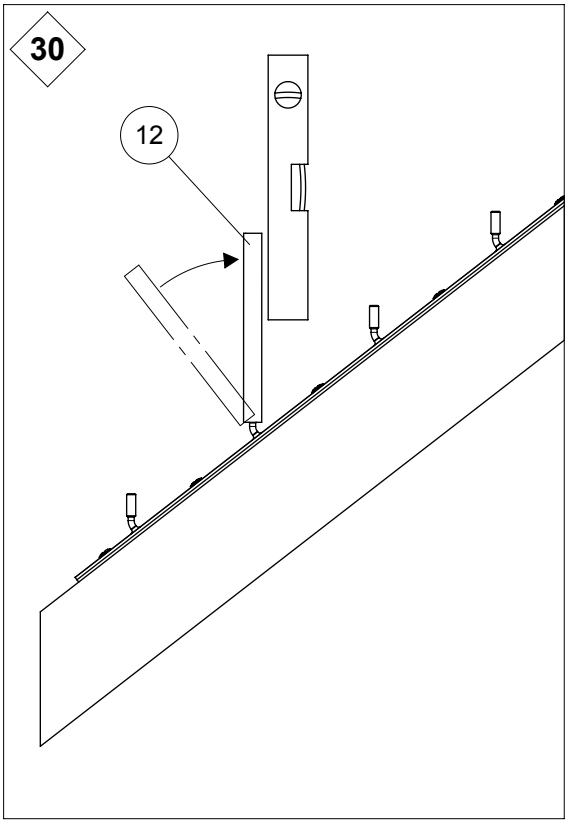

Hold stud with pliers.
Do not overtighten with
excessive force.

Sostenga el clavo con
una pinza. No apriete
de sobra usando fuerza
excesiva.

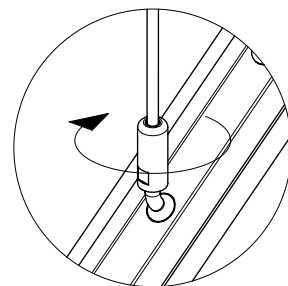

Pre bend the first cable tension fitting prior to installing complete (reference 36)
Pretorcer el primer herraje de tensión de cables antes de instalar completamente (referencia 36)

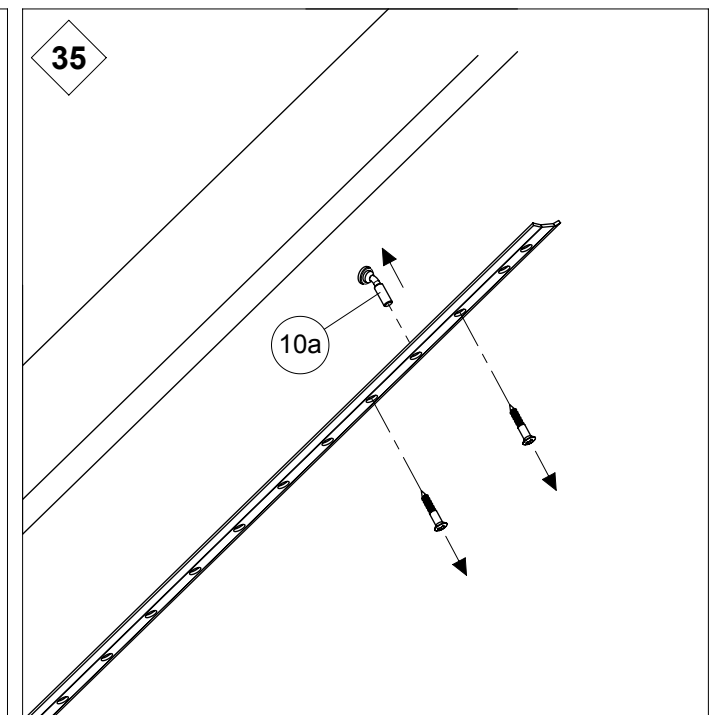
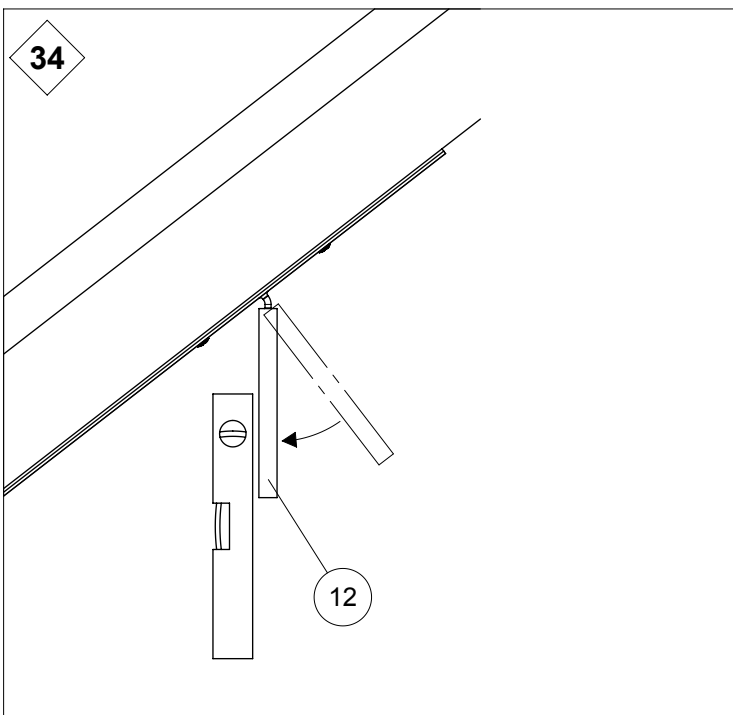
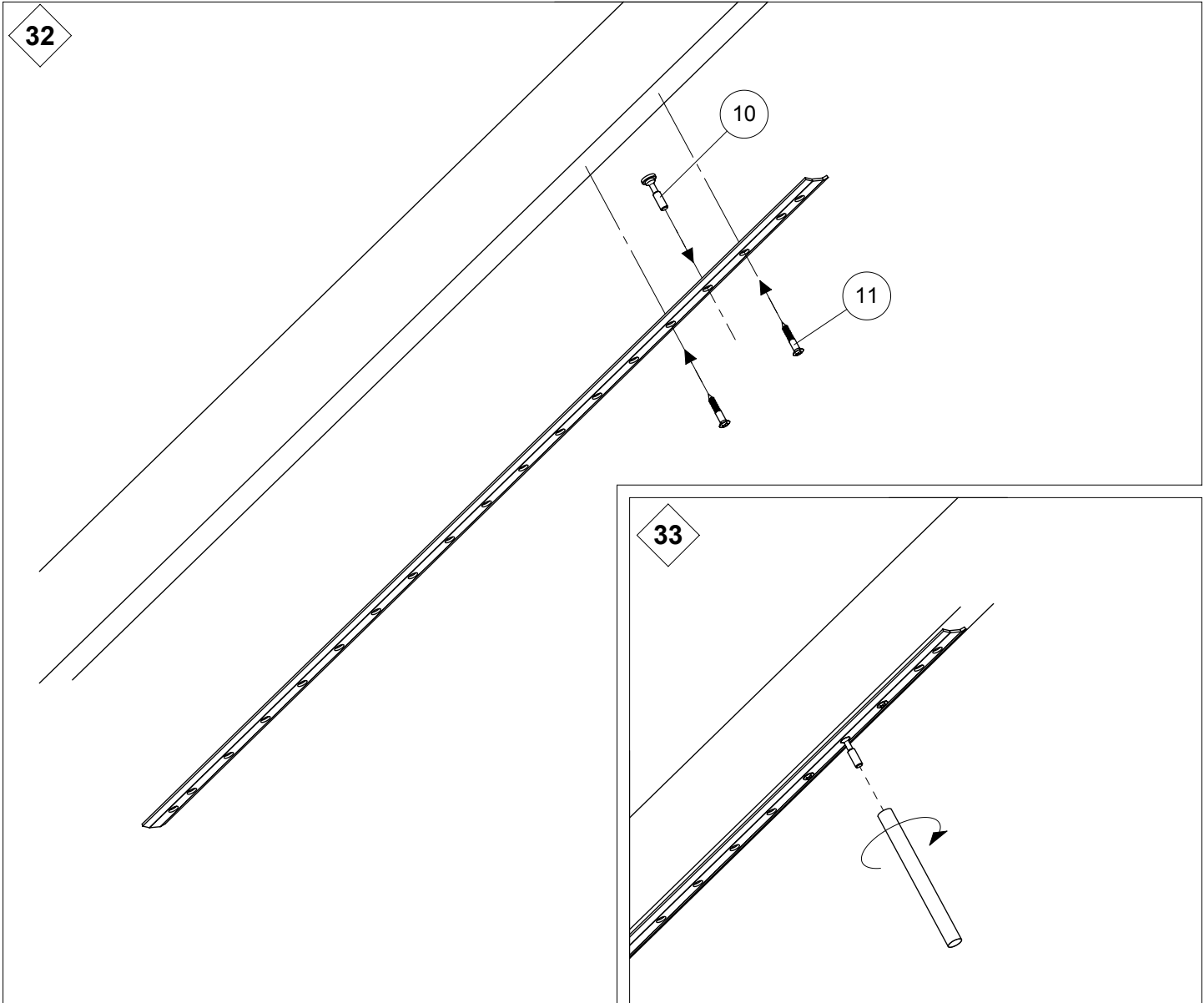

36

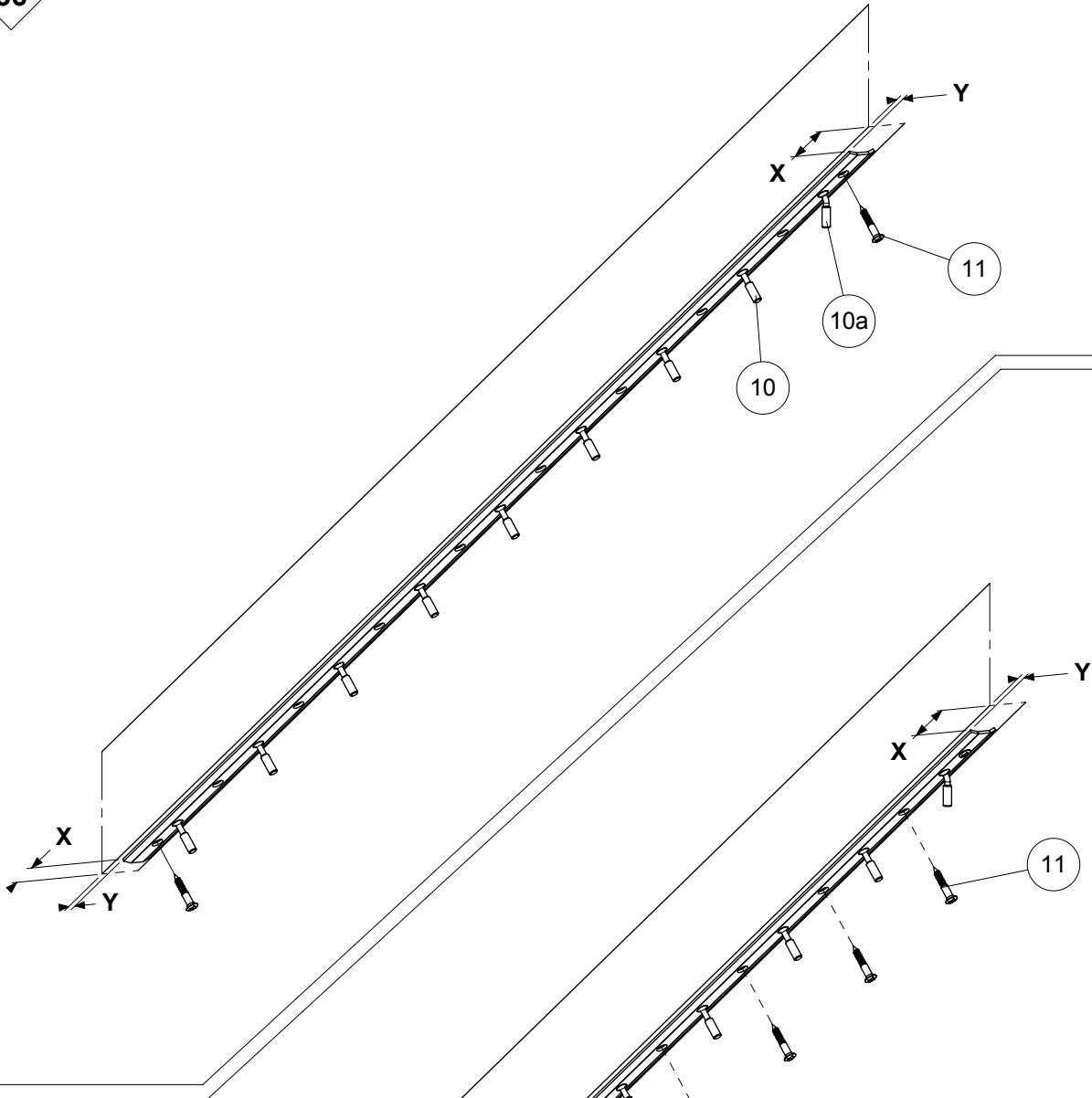

37

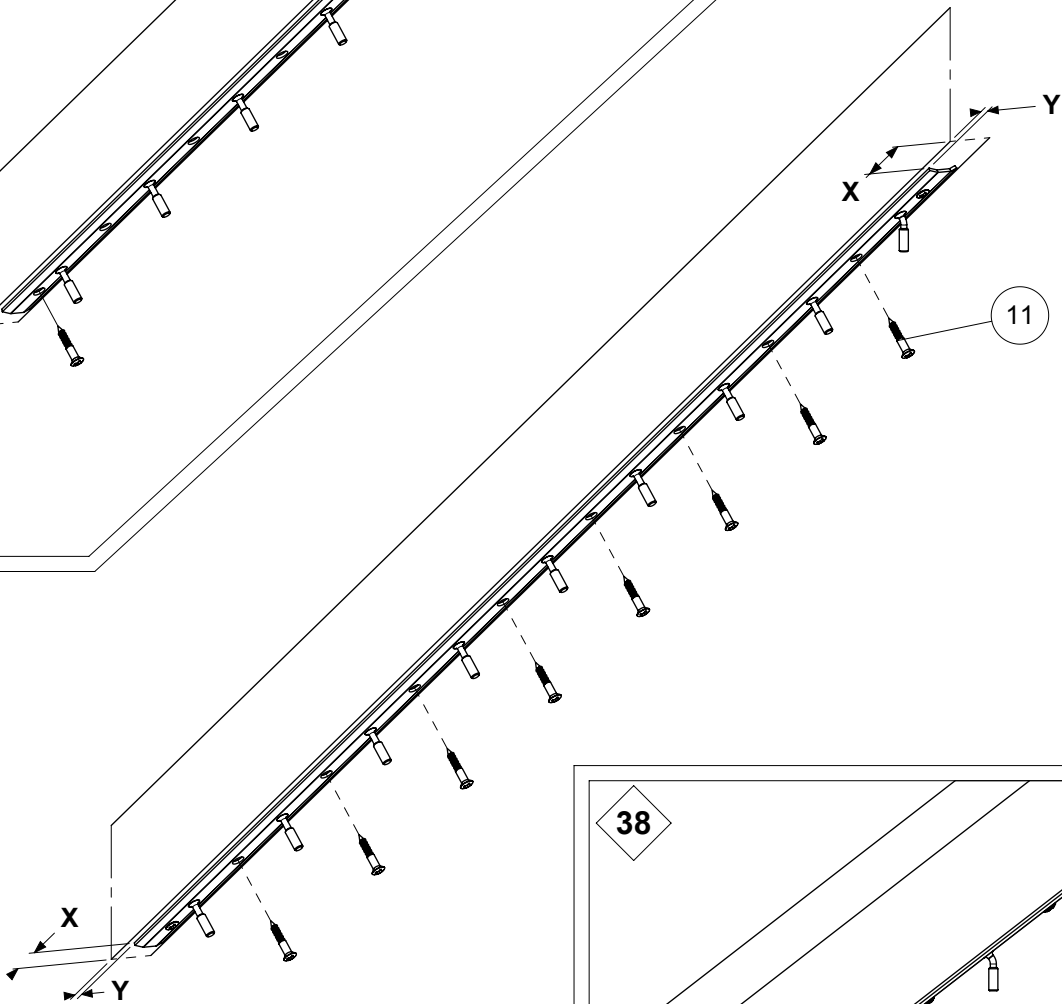

38

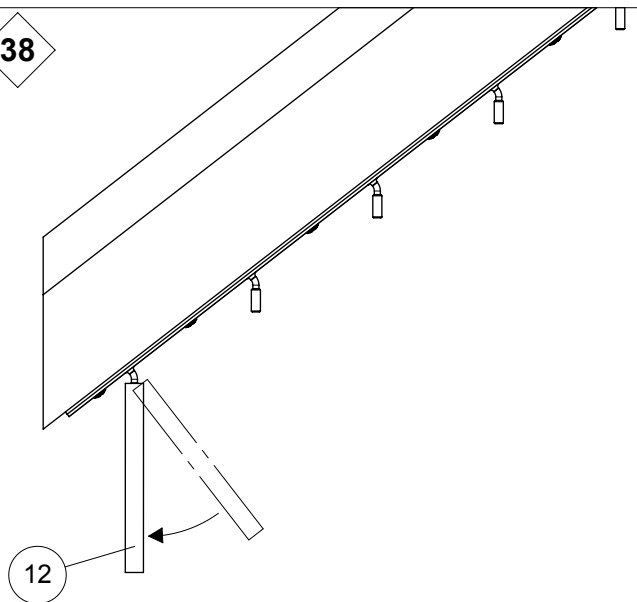

39

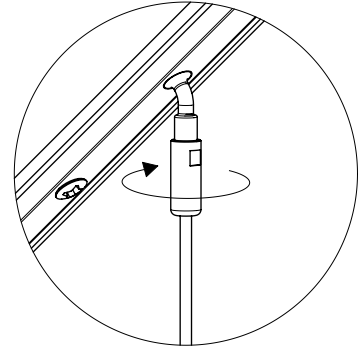

Hold stud with pliers.
Do not overtighten with
excessive force.

Sostenga el clavo con
una pinza. No apriete
de sobra usando fuerza
excesiva.

13

40

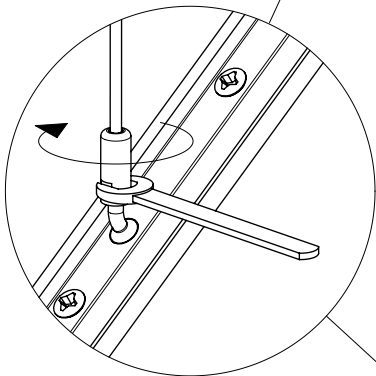

Hold stud with pliers.
Do not overtighten with
excessive force.

Sostenga el clavo con
una pinza. No apriete
de sobra usando fuerza
excesiva.

PLEASE NOTE

If the InstaRail system or wires have been subjected to excessive force, the tracks may have flexed, to prevent wires from breaking. In such cases, both wires and tracks must be replaced to ensure safe performance.

TENGA EN CUENTA

Si la barandilla "InstaRail" o los cables han sido sometidos a fuerza excesiva, las pistas se hayan deformado para evitar la ruptura de los cables. En tal caso, tanto los cables como las pistas deben ser reemplazadas para asegurar la seguridad del uso de la barandilla.