

BOSSJAMB™ PARTS LIST BREAKDOWN

MATCHING A DOOR TO BOSSJAMB™ HINGE AND LOCK PREP

Bossjamb™ Exterior Door Frame kits are factory routed for standard residential 4" hinges and lock strike hardware. They are ideal for blank exterior door slabs (doors that have not been routed for hinges and drilled for locks) up to 36" wide, 80" high, and 1-3/4" thick.

Refer to the hardware location illustration below to determine where to lay out hinges and lock bores on a blank door slab to match the hinge and lock prep on a Bossjamb™ Exterior Door Frame.

MEASURE FROM THE TOP OF THE DOOR TO:

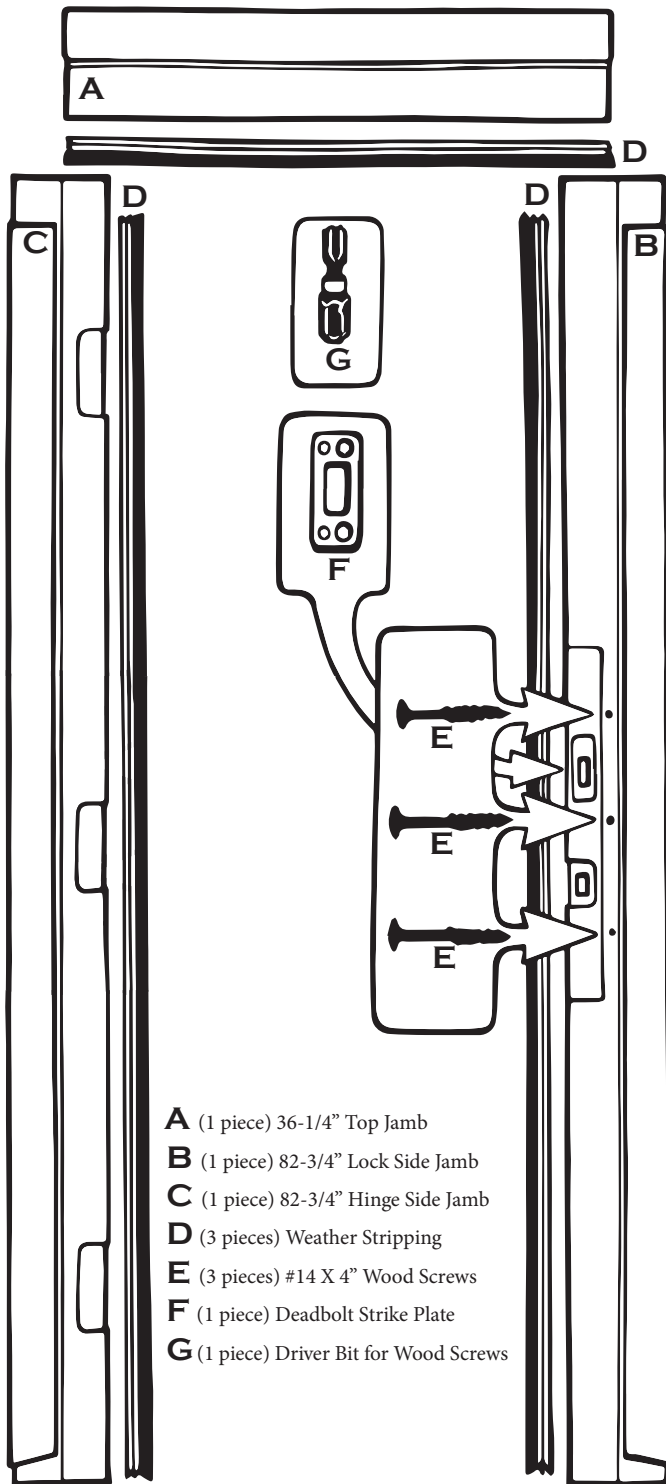
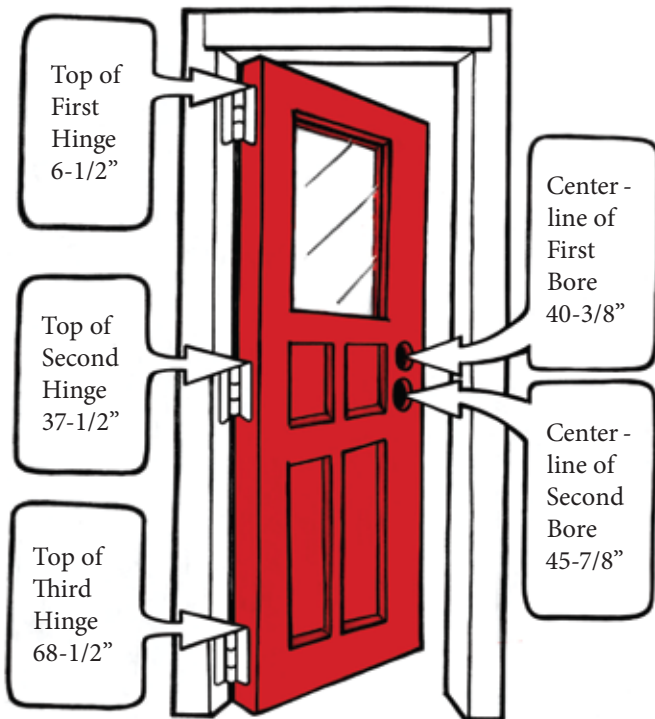

BOSS Jamb

BOSSJAMB™ BREAK-IN RESISTANT EXTERIOR DOOR FRAMES
 BY CRESCENT DOOR WORKS LLC
 NEW ORLEANS, LA
 WWW.BOSSJAMBS.COM

BOSSJAMB™ OVERVIEW AND ASSEMBLY

Bossjamb™ frames are for use only in rough openings framed for a single door, and are not recommended for use with sidelights. Begin by determining the swing of your exterior door and frame. Refer to the illustrations below to determine whether left hand inswing or right hand inswing Bossjamb™ door frame models are correct for your project.

LEFT HAND INSWING
VIEWED FROM EXTERIOR



BOSSJAMB™ MODEL 43068LHV2

RIGHT HAND INSWING
VIEWED FROM EXTERIOR



BOSSJAMB™ MODEL 43068RHV2

TOOLS REQUIRED FOR INSTALLATION:

- Safety Glasses
- Drill, 3/16" Drill Bit
- Tape Measure
- Miter Saw (needed only if jambs require trimming to fit non-standard door)
- Level
- Framing Square
- Caulk Gun

OTHER TOOLS NEEDED TO COMPLETE THE PROJECT:

- 3 Piece Brickmould Kit, Exterior Trim
- 3 Piece Interior Wood Trim Kit
- #9 X 2" Wood Screws
- Top Coat with 2 Coats Exterior Oil-Based or Latex Paint
- #9 X 3" Wood Screws
- Wood Shims
- Caulk

BOSSJAMB™ INSTALLATION INSTRUCTIONS

1. Bossjamb™ Exterior Door Frame kits are pre-cut to fit standard exterior doors 1-3/4" X 36" X 80". Begin by measuring the rough opening to ensure it is approximately 38-3/4" wide X 83-1/4" high (enough to fit the assembled Bossjamb™ frame, plus space in between the door frame and wall studs to make the frame square and level in the rough opening.) Bossjamb™ kits are easily trimmed with a handsaw or miter saw to custom fit non-standard doors.
2. Attach the hinge side and lock side jambs to the top jamb with #9 X 2" wood screws. The side jambs are pre-cut with a notch at the top and ready to fit to the top jamb. Attach the selected sill (not included) to the bottoms of the side jambs with #9 X 2" wood screws. The side jambs are pre-cut with a notch at the bottoms to fit the angle of standard residential sills.

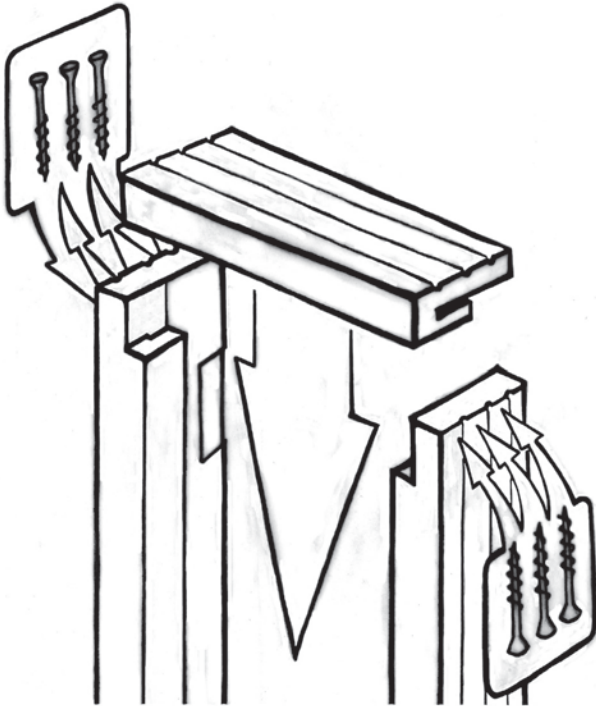

3. Center the assembled frame within the rough opening. Place wood shims outside all four corners of the frame so that it fits snugly within the rough opening. Check that the frame is plumb, square, and level.
4. Place wood shims behind all hinge and lock locations. Make sure the wood shims pass behind the cylindrical holes provided on the lock jamb. The #14 X 4" wood screws will screw into these holes (step 6) to engage with the steel reinforcements bonded inside the frame.

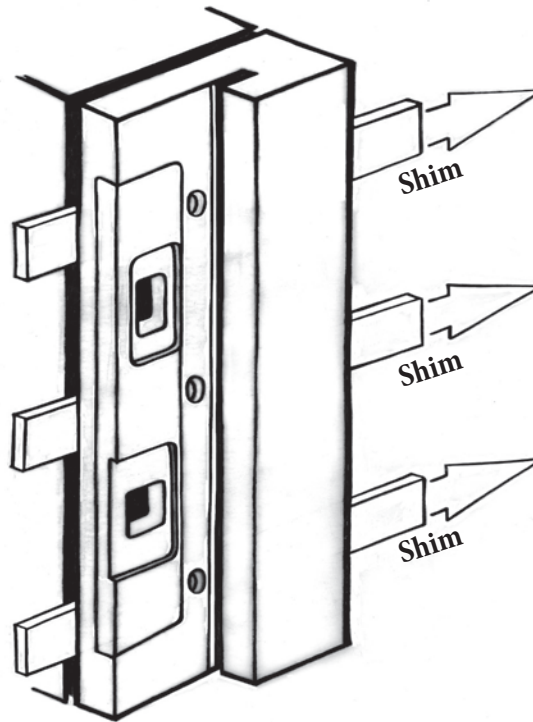

5. Screw the frame to the rough opening with #9 X 3" wood screws. Drive the screws through the hinge side and lock side jambs so that the weather stripping, once installed, will conceal the screw heads. Check that the frame is plumb, square, and level.

6. See illustration below. Drill a 3/16" diameter pilot hole through the center of each of the 3 cylindrical holes provided on the lock jamb. Drill approximately 3" deep into the wall studs. Pilot holes are smaller holes that will help guide the larger #14 X 4" wood screws. Next, drive the #14 X 4" wood screws into the pilot holes with the driver bit provided. Drive each wood screw slowly and firmly until it seats fully below the surface of the jamb. Do not overlook this step and use only the original screws provided with Bossjamb™.

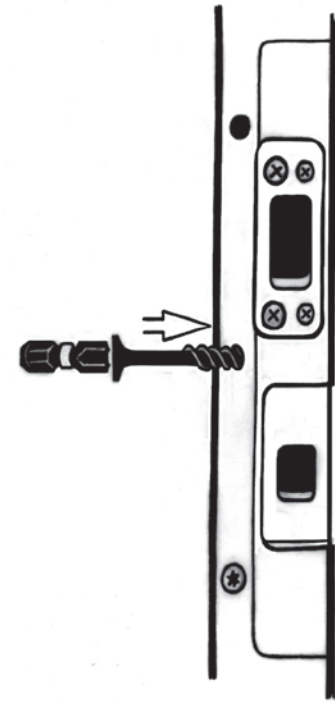

7. Mount strike plate hardware, hinges (not included), and weather stripping to the frame. Use #9 X 3" wood screws in the hinge holes nearest the weather stripping for additional frame strength and security.