



## TJERNLUND PRODUCTS, INC.

1601 Ninth Street • White Bear Lake, MN 55110-6794  
PHONE (800) 255-4208 • (651) 426-2993 • FAX (651) 426-9547  
Visit our web site • [www.tjernlund.com](http://www.tjernlund.com)



## MODEL X2D

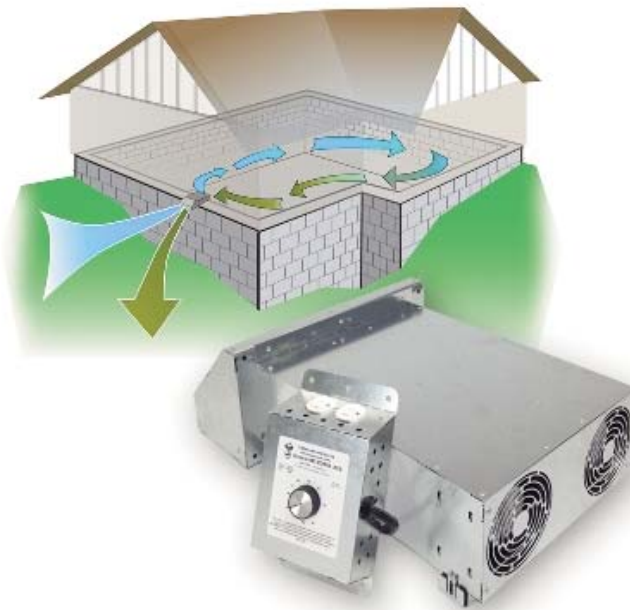

## INSTALLATION INSTRUCTIONS

**OWNER'S INSTRUCTIONS, DO NOT DESTROY**

THIS DEVICE MUST BE INSTALLED BY A  
QUALIFIED PERSON.

READ INSTRUCTIONS CAREFULLY PRIOR TO  
INSTALLATION AND OPERATION OF THE XCHANGER.

## TABLE OF CONTENTS

Descriptions and Specifications.....	1
Installation Restrictions.....	1
Cautions .....	2
Recommended Methods and Patterns of Operation.....	2-3
Recommended Installation and Termination Locations.....	3-4
XCHANGER™ Installation.....	4-6
Dehumidistat Control Module Installation & Operation .....	6
XCHANGER™ Ladder Diagram .....	6
Maintenance .....	7
How to Obtain Service & Warranty.....	7
Replacement Parts & Accessories .....	7

XCHANGER™ is a trademark of Tjernlund Products, Inc.

Tjernlund Products welcomes your comments and questions. Call us at (651) 426-2993, (800) 255-4208, Fax (651) 426-9547, email us at fanmail@tjfans.com or write to: Customer Service, Tjernlund Products, Inc., 1601 Ninth Street, White Bear Lake, MN 55110-6794.

## DESCRIPTION

The XCHANGER™ model X2D is a dual fan mechanical ventilator capable of exhausting inside air, providing fresh outside air or providing a balanced air exchange. The fans can be independently switched on or off or be easily reversed to provide fresh outside air or exhaust inside air. The X2D includes a dehumidistat control which operates the fan(s) based on the relative humidity sensed by the control inside the home. The dehumidistat control includes an "On" setting that will operate the fan(s) continuously or the switch can be turned "Off" so the fan(s) do not operate during undesirable seasons. The XCHANGER™ can also be operated by a standard plug-in timer. Tjernlund's optional SCP speed control kit is also available if desired.

## SPECIFICATIONS

### MODEL X2D XCHANGER

	1 FAN	2 FANS
Voltage	120	120
Watts	20	40
Amps	0.3	0.6
CFM	90	180

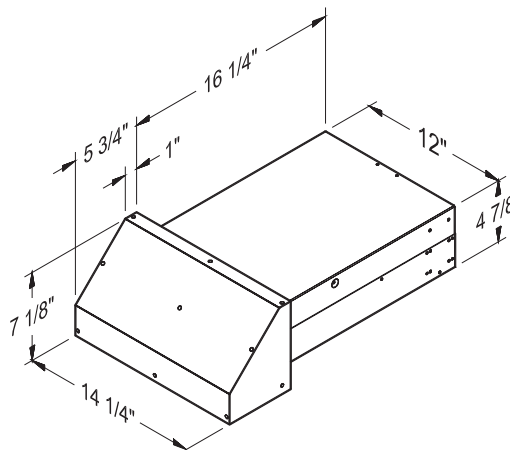

Dehumidistat: 20% - 80% RH Range

Rough-in Wall Opening Dimensions: 12 1/4" x 5 1/4"

## GENERAL INFORMATION

Each XCHANGER™ is electrically factory line tested before shipment. After opening carton, inspect thoroughly for hidden damage.

## INSTALLATION RESTRICTIONS

**WARNING:** Improper installation, adjustment, alterations, service or maintenance can cause injury or property damage. Refer to this manual. For assistance or additional information consult a qualified installer, service agency or the equipment supplier.

**WARNING:** Sufficient air is needed for proper combustion and exhausting of gases through the flue (chimney) of fuel burning equipment to prevent backdrafting. Follow the heating equipment manufacturer's guideline and safety standards such as those published by the National Fire Protection Association (NFPA), and the American Society for Heating, Refrigeration and Air Conditioning Engineers (ASHRAE), and the local code authorities.

**WARNING:** Do not exhaust air from mechanical room unless makeup air is also supplied or equipment in mechanical room is sealed combustion. Carbon monoxide poisoning may result. Use the DT2-6 6" duct take-off kit so exhaust can be removed from outside the mechanical room if necessary.

Observe proper location of hood as described on page 3. The XCHANGER™ must only be installed with the hood on an exterior wall.

Only XCHANGER™ fans can be plugged into dehumidistat control module or damage may result.

Do not discharge intake air onto water pipes or other equipment which may be affected by temperature extremes.

## CAUTIONS

**WARNING:** Failure to install, maintain and/or operate the XCHANGER™ in accordance with manufacturer's instructions may result in conditions that can produce bodily injury and property damage.

Disconnect power supply to fans and/or control when reversing fan direction or servicing the XCHANGER™. Failure to do so may result in personal injury and/or equipment damage.

Make certain the power source is adequate for the XCHANGER™ requirements. Do not add the XCHANGER™ to a circuit where the total electrical load is unknown.

## XCHANGER DEHUMIDISTAT CONTROL MODULE OPERATION

The XCHANGER™ control module includes an adjustable dehumidistat control which activates the fan(s) if the relative humidity rises above the selected set-point. It is generally recommended to maintain a Relative Humidity (RH) below 60% to inhibit mold growth. The dehumidistat can be turned fully clockwise to the 'on' position for constant fan(s) operation or it can be turned fully counter-clockwise to 'off' during seasons or times when it is not desired for the XCHANGER™ fan(s) to run. Each fan can be independently turned on/off by its fan switch on control module.



## STANDARD PLUG-IN TIMER OPERATION

A standard adjustable timer can also be utilized for timed operation of the XCHANGER™ fan(s). Plug timer into standard outlet and plug XCHANGER™ control module into wall timer. Turn dehumidistat control fully clockwise to the 'on' position. Both outlets in XCHANGER™ control module will be controlled by the wall timer. Each fan can be independently turned on/off by its fan switch on dehumidistat control module. You can also allow the dehumidistat control to turn the XCHANGER™ on during certain times of the day if you use a timer and keep the dehumidistat control at the desired set-point.



## TJERNLUND OPTIONAL SCP SPEED CONTROL OPERATION

Tjernlund's optional SCP speed control can be used to vary the speed of both XCHANGER™ fans. Plug SCP speed control into standard outlet and plug XCHANGER™ control module into SCP speed control. Both outlets in XCHANGER™ control module will be controlled by the SCP speed control. Each fan can be independently turned on/off by its fan switch on dehumidistat control module.



## RECOMMENDED PATTERNS OF OPERATION

The XCHANGER™ X2D model includes a dehumidistat control which can cycle the XCHANGER™ fan(s) automatically based on the relative humidity level of the house or it can be operated based on recommendations below. It is generally recommended to maintain a Relative Humidity (RH) below 60% to inhibit mold growth.

A standard plug-in wall timer can be programmed based on the lifestyle or needs of the occupants. For example, a family with smokers may want to cycle the XCHANGER™ more frequently than a family of non-smokers.

Another timed method may be to cycle the XCHANGER™ during peak usage of exhaust fans, such as bathroom, kitchen, laundry or utility. Outdoor air should be brought in at these peak times to help balance out pressure inside the house.

The XCHANGER™ can be cycled on and off at regular intervals to periodically provide fresh air to the home, exhaust stale air or have one fan bring air in and the other fan exhaust air for a balanced air exchange. It can also be ran like an economizer to bring outside air in during evening time when it is cooler outside.

## HYPOTHETICAL XCHANGER OPERATION BASED ON LIFESTYLE

The example below shows a possible way in which cycling times of the XCHANGER™ may be determined based on household occupant lifestyles.

**6:00 A.M. to 9:00 A.M.** = Outside fresh air should be brought into the house to compensate for morning routines. Bathing, cooking, laundry and other activities such as smoking necessitate that outside fresh air to be brought in. Depressurization of the house at these times is common with many exhaust fans running at one time.

**9:00 A.M. to 4:00 P.M.** = House is normally vacant with occupants at work or school. Cycle XCHANGER™ on and off for 15 minute intervals per hour to assure fresh air is supplied to the house.

**4:00 P.M. to 8:00 P.M.** = Outside fresh air should be brought into the house to compensate for evening routines. Bathing, cooking, laundry and other activities such as smoking necessitate that outside fresh air to be brought in. Depressurization of the house at these times is common with many exhaust fans running at one time.

**8:00 P.M. to 6:00 A.M.** = All members of the household are usually present. Outside fresh air is needed to dilute occupant generated carbon dioxide during sleeping. Cycle XCHANGER™ on and off for 15 minute intervals, with occasional 30 minute intervals to assure fresh air is supplied to house.

## XCHANGER OPERATION BASED ON AIR CHANGES PER HOUR

This method of operation can be used to supplement or provide for guaranteed air change rates. Table 1 shows the constant Cubic Feet Per Minute (CFM) of air necessary to produce the desired Air Change Per Hour rate (ACH), assuming natural infiltration of outside air at a rate of .10 ACH. Square footage is determined by calculating the finished living space of the house. Garages and crawl space should not be included. The constant CFM figures shown assume that the living space has standard 8 foot ceilings.

TABLE 1 DESIRED AIR CHANGES PER HOUR (ACH)

		0.15	0.20	0.25	0.30	0.35
SQUARE FOOTAGE OF LIVING SPACE	1000	7	13	20	27	33
	1500	10	20	30	40	50
	2000	13	27	40	53	67
	2500	17	33	50	67	83
	3000	20	40	60	80	100

1. Determine square footage of house living space on left hand column.
2. Pick desired air change rate from top row.
3. Locate intersection of these points to determine constant CFM that should be obtained to meet desired ACH.

The XCHANGER™ will provide 180 CFM with both fans and 90 CFM with one fan operating. Where the CFM delivery of the XCHANGER™ exceeds that listed in Table 1, a standard plug-in timer can be set so the XCHANGER™ is cycled to obtain the desired ACH or Tjernlund's optional SCP speed control may be used.

### EXAMPLE

3000 square feet of living space  
 .2 ACH desired ventilation rate equals 40 CFM  
 XCHANGER™ capacity of 90 CFM (with one fan running)

In this example the plug-in timer may be set so that the XCHANGER™ operates for one half hour straight each hour or two fifteen minute periods each hour.

## RECOMMENDED INSTALLATION LOCATION

The XCHANGER™ may be mounted anywhere in the house. The best place to mount it is the basement through the rim joist on top of the foundation wall.

**WARNING:** Do not exhaust air from mechanical room unless makeup air is also supplied or equipment in mechanical room is sealed combustion. Carbon monoxide poisoning may result. Use the optional DT2-6 6" duct take-off kit so exhaust can be removed from outside the mechanical room if necessary.

It is required that the XCHANGER™ be installed in a location where it will not be directed at the occupants. Do not discharge intake air onto water pipes or other equipment which may be affected by temperature extremes.

Do not terminate adjacent to thermostat. Outside temperatures can disrupt normal thermostat operation.

Do not terminate within three feet from a barometric draft control or intake grille of a heating appliance.

## XCHANGER HOOD TERMINATION CLEARANCES

Install XCHANGER™ in accordance with BOCA national Mechanical Codes M-306.1 and M-306.1.1 as follows, (See Diagram A).

**M-306.1 LOCATION:** Outside air exhaust and intake openings shall be located a minimum of 10 feet (3048mm) from lot lines or buildings on the same lot. When openings front on a street or public way, the distance shall be measured to the centerline of the street or public way.

**M-306.1.1 INTAKE OPENINGS:** Outside air intake openings shall be located a minimum of 10 feet (3048mm) from any hazard or noxious contaminant such as vents, chimneys, plumbing vents, streets, alleys, parking lots and loading docks. When a source contaminant is located within 10 feet (3048mm) of an intake opening, such opening shall be located a minimum of 2 feet (610mm) below the contaminant source.

### IN ADDITION TO THESE CODES THE MANUFACTURER RECOMMENDS THAT:

- The XCHANGER™ hood should be a minimum of 1 foot above grade or anticipated snow line.
- The XCHANGER™ hood should be a minimum of 3 feet from an inside corner of the building.

DIAGRAM A

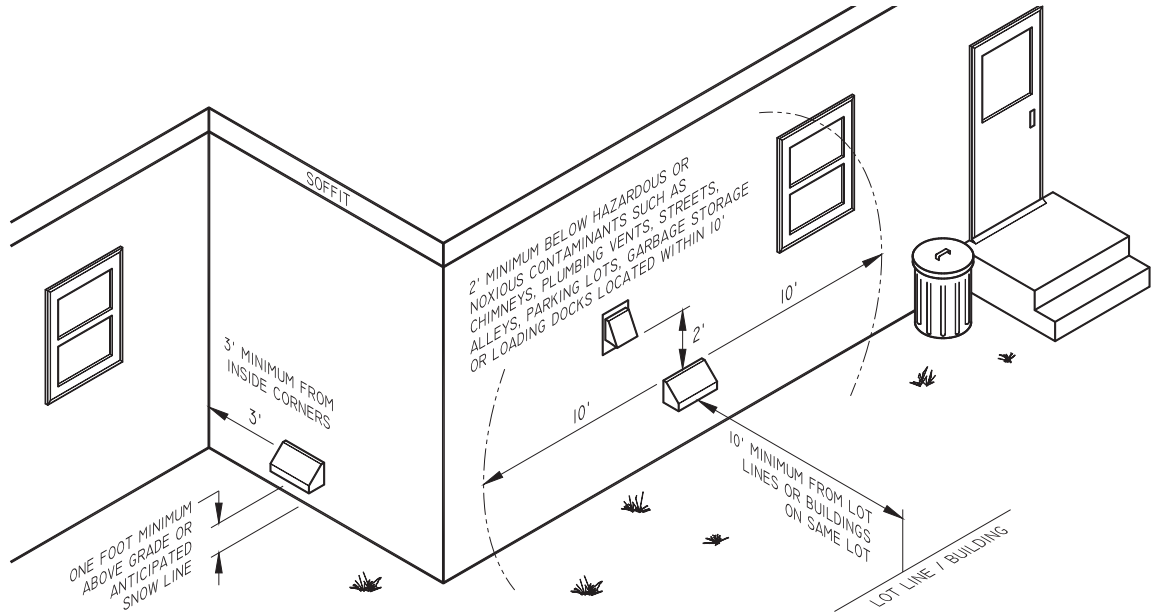

**INSTALLATION (TOOLS REQUIRED)**

- Reciprocating saw
- Drill and 1/2" bit
- 5/16" nut runner or socket
- Phillips screwdriver
- Siding tools (dependent on exterior finish)
- Level

**INSTALLATION**

**NOTE:** Before cutting opening through wall, confirm XCHANGER™ hood termination clearances are met as noted on bottom of page 3.

1. A) Center template and tape to the rim joist between the floor joists/trusses XCHANGER™ will be mounted through, (See Diagram B).  
 B) If XCHANGER™ is not installed between floor joists or trusses, attach the template to the wall it will be exiting, ensuring XCHANGER™ will be level.
2. **CAUTION:** When cutting or drilling into wall, do not damage electrical wiring and other hidden utilities. Using a 1/2" bit, drill pilot holes noted on the template from inside through rim joist, wall board, siding, etc., keeping drill bit perpendicular to the wall. 1/2" bit must be long enough to penetrate through exterior.
3. Use a level to mark (4) holes drilled in step 2 and connect the holes on building exterior, (See Diagram C). Use a saw to remove material between marks, (See Diagram D).

DIAGRAM B



CENTER TEMPLATE BETWEEN JOIST OR PLACE ON WALL XCHANGER WILL EXIT.

DIAGRAM C



DRILL (4) 1/2" CORNER HOLES THROUGH WALL FROM INTERIOR AND CONNECT HOLES ON EXTERIOR WITH A LEVEL.

DIAGRAM D



CUT OPENING ALONG MARKED LINES.

- Remove fans if necessary and insert XCHANGER™ housing through exterior wall opening with fan openings facing down, (See Diagram G). For vinyl or other types of lap siding, level XCHANGER™ and trace outer flange on XCHANGER™ housing and trim siding back enough to install J channel or appropriate flashing, (See Diagram E).
- Place a bead of caulk on XCHANGER™ mounting flange or building sheathing before inserting housing, (See Diagram F).
- Remove fans if necessary and insert XCHANGER™ housing through exterior wall opening with fan openings facing down, (See Diagram G).

DIAGRAM E



LEVEL XCHANGER AND TRACE FLANGE. TRIM SIDING BACK SO XCHANGER FLANGE CAN BE MOUNTED FLUSH TO EXTERIOR SHEATHING.

DIAGRAM F



PLACE A BEAD OF CAULK ON XCHANGER MOUNTING FLANGE OR BUILDING SHEATHING BEFORE INSERTING HOUSING.

DIAGRAM G



INSERT XCHANGER HOUSING THROUGH WALL. FAN OPENINGS MUST FACE DOWN.

- Level housing and secure to wall using (4) screws, (See Diagram H). Install J channel or appropriate flashing around XCHANGER™ mounting flange. Do not cover up mounting flange or hood may not fit in J channel, (See Diagram I).

DIAGRAM H



LEVEL HOUSING AND SECURE TO WALL USING (4) SCREWS.

DIAGRAM I



INSTALL J CHANNEL OR APPROPRIATE FLASHING AROUND XCHANGER MOUNTING FLANGE.

DIAGRAM J



HOOK X2D HOOD ON HOUSING TOP FLANGE, CENTER AND BEND TAB OVER ON EACH SIDE ON BOTTOM OF HOOD.

- Apply a bead of caulk around hood and siding, (See Diagram K).

- Insert plastic nut into XCHANGER™ base. Assemble mounting bracket as shown, (See Diagram M). Attach assembled bracket to bottom of XCHANGER™. Mark bracket mounting location on wall with a slight upward pitch in rear of XCHANGER™ and connect to wall using provided wall anchor, (See Diagram L).

DIAGRAM K



APPLY A BEAD OF CAULK AROUND HOOD AND SIDING.

DIAGRAM L



ATTACH MOUNTING BRACKET TO BOTTOM OF XCHANGER. INSTALL BRACKET SO XCHANGER HAS A SLIGHT UPWARD PITCH IN REAR.

DIAGRAM M

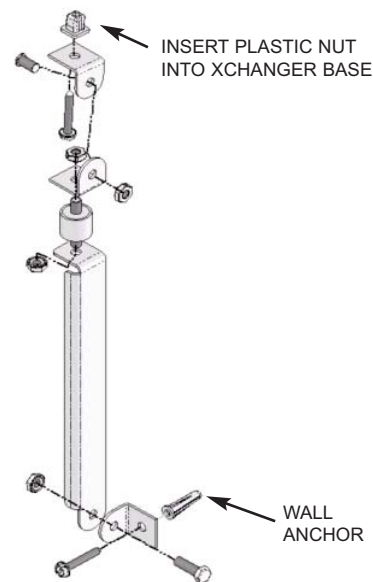

ASSEMBLE XCHANGER MOUNTING BRACKET.

11. The XCHANGER™ comes with (2) air infiltration magnetic draft stops to block incoming air during seasons or periods when the XCHANGER™ is not in use if desired. Place magnet(s) over XCHANGER™ fan opening(s) when fan is not in use to block air infiltration. Place magnet(s) on side of XCHANGER™ cabinet so they are not lost if not in use to block fan openings, (See Diagram N).
12. **WARNING:** Unplug fans from dehumidistat control when changing fan direction to prevent damage or injury. Insert fans in desired direction for either exhaust or intake. See arrow on bottom of fan cartridge or side of fan shroud for air flow direction. Once installed confirm the air is being exhausted or supplied depending upon application, (See Diagram O).
13. Insulate around XCHANGER™ housing, (See Diagram P).

DIAGRAM N



PLACE MAGNETIC DRAFT STOPS OVER XCHANGER FAN OPENING(S) WHEN FAN IS NOT IN USE TO BLOCK AIR INFILTRATION IF DESIRED. PLACE ON SIDE OF CABINET IF NOT IN USE SO THEY ARE NOT LOST.

DIAGRAM O



**WARNING:** UNPLUG FANS WHEN CHANGING DIRECTION. SEE ARROW ON BOTTOM OF FAN CARTRIDGE OR SIDE OF FAN SHROUD FOR AIR FLOW DIRECTION.

DIAGRAM P



INSULATE AROUND XCHANGER HOUSING.

### XCHANGER DEHUMIDISTAT CONTROL MODULE INSTALLATION & OPERATION

Install XCHANGER™ dehumidistat control module on wall with provided screws and wall anchors and plug XCHANGER™ fans into side outlets.

**IMPORTANT:** Do not plug other devices into dehumidistat control or damage may result. Once fans are installed in XCHANGER™, plug dehumidistat control into standard outlet.

The XCHANGER™ control module includes an adjustable dehumidistat control which activates the fan(s) if the relative humidity rises above the selected set-point. It is generally recommended to maintain a Relative Humidity (RH) below 60% to inhibit mold growth. The dehumidistat can be turned fully clockwise to the 'on' position for constant fan(s) operation or it can be turned fully counter-clockwise to 'off' during seasons or times when it is not desired for the XCHANGER™ fan(s) to run. Each XCHANGER™ fan is independently controlled by its own on/off switch. Turn switch(s) off during seasons or applications where it is not desired to run that fan, (See Diagram Q).

DIAGRAM Q



SCREW DEHUMIDISTAT CONTROL TO WALL AND PLUG FANS INTO SIDE OUTLETS.

### XCHANGER LADDER DIAGRAM

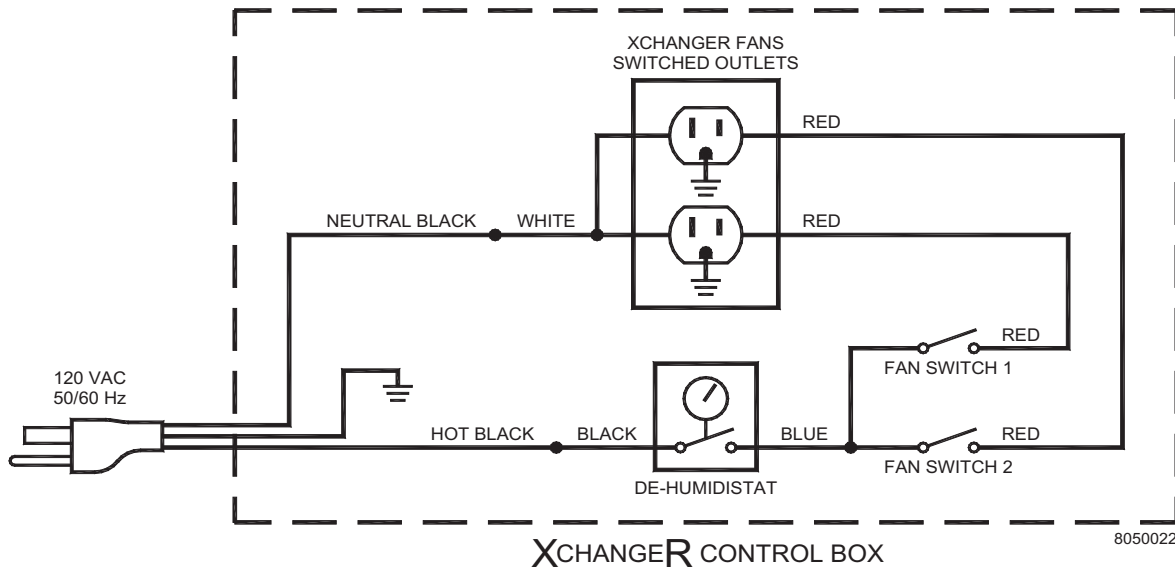

8050022

## MAINTENANCE

The XCHANGER™ hood screen must be inspected every 3 to 6 months. Remove any foreign material such as leaves, lint, cottonwood or other items. Remove screen to clean if necessary, (See Diagram R).

INSERT HOOD  
SCREEN IN HOOD  
GUIDES.

DIAGRAM R



## HOW HOW TO OBTAIN SERVICE ASSISTANCE

1. If you have any questions about your XCHANGER™ or if it requires adjustment, repair or routine maintenance, we suggest that you contact your installer, contractor or service agency.
2. If you require technical information contact Tjernlund Products, Inc. at 1-800-255-4208 or email us at fanmail@tjfans.com.

When contacting Tjernlund Products, Inc., please have the following information available:

1. Model number and date code of the XCHANGER™
2. Name and address of installer and service agency
3. Date of original installation and dates any service work was performed
4. Details of the problem

## LIMITED PARTS WARRANTY AND CLAIM PROCEDURE

Tjernlund Products, Inc. warrants the components of the XCHANGER™ for one year from date of installation. This warranty covers defects in material and workmanship. This warranty does not cover normal maintenance, transportation or installation charges for replacement parts or any other service calls or repairs. This warranty DOES NOT cover the complete XCHANGER™ if it is operative, except for the defective part.

Tjernlund Products, Inc. will issue credit or provide a free part to replace one that becomes defective during the one year warranty period. All receipts should include the date code of the XCHANGER™ to ensure that the defective component corresponds with the complete unit. This will help prevent possible credit refusal.

- 1.) Follow troubleshooting guide to determine defective component. If unable to determine faulty component, contact your Tjernlund distributor, Tjernlund Products Technical Customer Service Department at 1-800-255-4208 for troubleshooting assistance or email us at fanmail@tjfans.com.
- 2.) After the faulty component is determined, return it to your Tjernlund distributor for replacement. Please include XCHANGER™ date code component was taken from. Credit or replacement will only be issued to a Tjernlund distributor after the defective part has been returned prepaid to Tjernlund.

## WHAT IS NOT COVERED

Product installed contrary to our installation instructions  
Product that has been altered, neglected or misused  
Any freight charges related to the return of the defective part  
Any labor charges related to evaluating and replacing the defective part

### TJERNLUND LIMITED 1 YEAR WARRANTY

Tjernlund Products, Inc. warrants to the original purchaser of this product that the product will be free from defects due to faulty material or workmanship for a period of (1) year from the date of original purchase or delivery to the original purchaser, whichever is earlier. Remedies under this warranty are limited to repairing or replacing, at our option, any product which shall, within the above stated warranty period, be returned to Tjernlund Products, Inc. at the address listed below, postage prepaid. THERE ARE NO WARRANTIES WHICH EXTEND BEYOND THE DESCRIPTION ON THE FACE HEREOF, AND TJERNLUND PRODUCTS, INC. EXPRESSLY DISCLAIMS LIABILITY FOR INCIDENTAL OR CONSEQUENTIAL DAMAGES ARISING FROM THE USE OF THIS PRODUCT. THIS WARRANTY IS IN LIEU OF ALL OTHER EXPRESS WARRANTIES AND NO AGENT IS AUTHORIZED TO ASSUME FOR US ANY LIABILITY ADDITIONAL TO THOSE SET FORTH IN THIS LIMITED WARRANTY. IMPLIED WARRANTIES ARE LIMITED TO THE STATED DURATION OF THIS LIMITED WARRANTY. Some states do not allow limitation on how long an implied warranty lasts, so that limitation may not apply to you. In addition, some states do not allow the exclusion or limitation of incidental or consequential damages, so that above limitation or exclusion may not apply to you. This warranty gives you specific legal rights and you may also have other rights which may vary from state to state. Send all inquiries regarding warranty work to Tjernlund Products, Inc. 1601 9th Street, White Bear Lake, MN 55110-6794. Phone (651) 426-2993 • (800) 255-4208 • Fax (651) 426-9547 • Email fanmail@tjfans.com.

## XCHANGER PARTS AND ACCESSORIES

### REPLACEMENT PARTS

XCHANGER™ Fan Assembly	950-8350
XCHANGER™ Dehumidistat	950-8351
XCHANGER™ X2D Hood Screen	950-8352
XCHANGER™ X2D Hood with Screen	950-8353
XCHANGER™ Magnetic Draft Stops (2)	950-8354

### ACCESSORIES

6" Duct Take-Off Kit	DT2-6
Plug-In Speed Control	SCP