



OUTDOOR STORAGE

MODEL N° 60065

OWNER'S MANUAL

Keep this Identification Number in case you must contact our Customer Service Department.

REGISTER YOUR LIFETIME PRODUCT TODAY!

There are benefits to registering your Lifetime product. With our new online product registration form, it's fast and easy! Register with us at www.lifetime.com and enjoy these great benefits:

- Receive exclusive money-saving offers from BuyLifetime.com, our online store, as well as NEW product notifications and special closeout promotions!
- In the unlikely event of a product recall or safety modification, we will notify you.
- Registering your product guarantees you warranty service. If you do not register your product, your warranty rights will not be diminished. But you will need to provide a sales receipt to verify your product purchase date before warranty service will be provided.

LIFETIME'S PROMISE TO YOU:

Maintaining your privacy is our long-standing policy at Lifetime. And you can rest assured that Lifetime will not sell or provide your personal data to other third parties, or allow them to use your personal data for their own purposes.

We invite you to read our privacy policy at www.lifetime.com

REGISTER today!

****U.S. and Canada customers ONLY****

IF ASSISTANCE IS NEEDED,

DO NOT CONTACT THE STORE!

CALL OUR CUSTOMER SERVICE DEPARTMENT at 1 (800) 225-3865

HOURS: 7:00 a.m. to 5:00 p.m. Monday through Friday (Mountain Standard Time)

Call, or visit our Web site for Saturday hours

For customers outside the U.S. or Canada, please contact the store for assistance.



SAFETY INSTRUCTIONS



FAILURE TO FOLLOW THESE WARNINGS MAY RESULT IN SERIOUS INJURY OR PROPERTY DAMAGE AND WILL VOID WARRANTY.

To ensure safety, do not attempt to assemble this product without following the instructions carefully. Check entire box and inside all packing material for parts and/or additional instruction material. Before beginning assembly, read the instructions and identify parts using the hardware identifier and parts list in this document. Proper and complete assembly, use, and supervision are essential to reduce the risk of accident or injury. A high probability of serious injury exists if this system is not installed, maintained, and/or operated properly.

- Follow any and all warnings and cautions carefully
- Assembly on level ground.
- Do not stand on Raised Garden Bed Panels.

Most injuries are caused by misuse and/or not following instructions. Use caution when using this system.

STOP!

BEFORE BEGINNING ASSEMBLY

STOP!



Keep the hardware bags and their contents separate. If any parts are missing, call our Customer Service Department.



Identify and inventory all parts and hardware using the parts and hardware lists and identifiers in this document.

**Only adults should set up the product. Do not allow children
in the setup area until assembly is complete.**



TOOLS REQUIRED FOR THIS ASSEMBLY

Safety Glasses

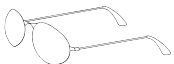

(1 pair for each person)

ASSEMBLY GUIDES

Refer to the following areas throughout the instructions to assist in the assembly process:

This area is located at the top, left-hand corner of the page and indicates which tools and hardware are needed to complete the assembly steps on a page.



TOOLS AND HARDWARE REQUIRED FOR THIS PAGE



This area is located at the top, right-hand corner of the page and shows an image of the product with shaded parts indicating which section is being assembled.

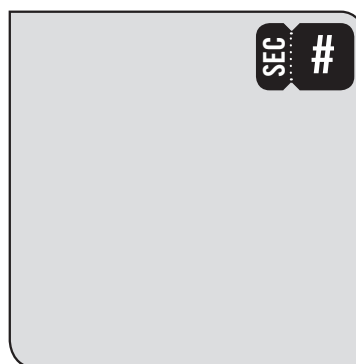

This area is usually located in the bottom, left-hand corner of a step and indicates that special attention is needed to perform a particular part of a step.



Note:

These areas are usually located in the bottom, right-hand corner of a step and indicate that damage to the product or serious injury may occur if the caution or warning is not heeded.



CAUTION



WARNING

Throughout the Parts & Hardware List, Part & Hardware Identifiers, and instructions are three-letter IDs. These IDs are below the images of the parts and hardware to help you locate and identify the parts and hardware during assembly. These IDs are not necessarily on the parts themselves.

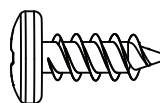

ADZ (x10)
1/4" x 5/8" Pan-Head Screw

PARTS LIST

PARTS BOX

ID	Description	Qty	ID	Hardware Description	Qty
CTJ	Bed Panel	4	CUI	SMALL PARTS BAG	
			CUC	Panel Clip	4
			CWA	Blow Hole Plug	8

PARTS IDENTIFIER

Part shown at 8% of actual size

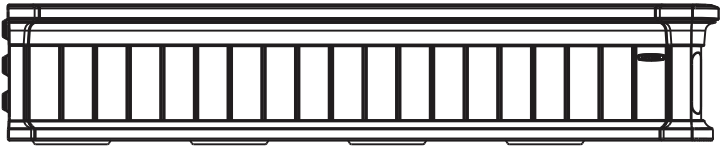

CTJ (x4)
Bed Panel

SMALL PARTS IDENTIFIER

RAISED GARDEN BED HARDWARE [CUI]

Hardware shown at actual size

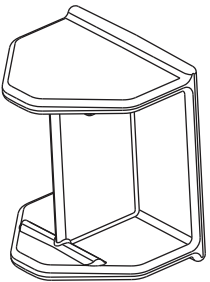

CUC (x4)
Panel Clip



CWA (x8)
Blow Hole Plug



TOOLS AND HARDWARE REQUIRED FOR THIS PAGE

SEC 1



NO HARDWARE OR PARTS PROVIDED FOR THIS STEP

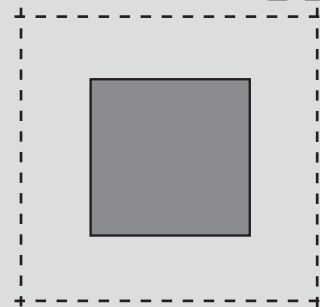

SEC

SITE PREPARATION

1.1

The actual dimensions of your Raised Garden Bed (at its widest and longest points) are 48 3/4" x 48 3/4". Ensure you select a site that will accommodate these measurements with **at least 24"** of additional space for maneuvering around each Raised Garden Bed as you garden. Ensure ground is level.

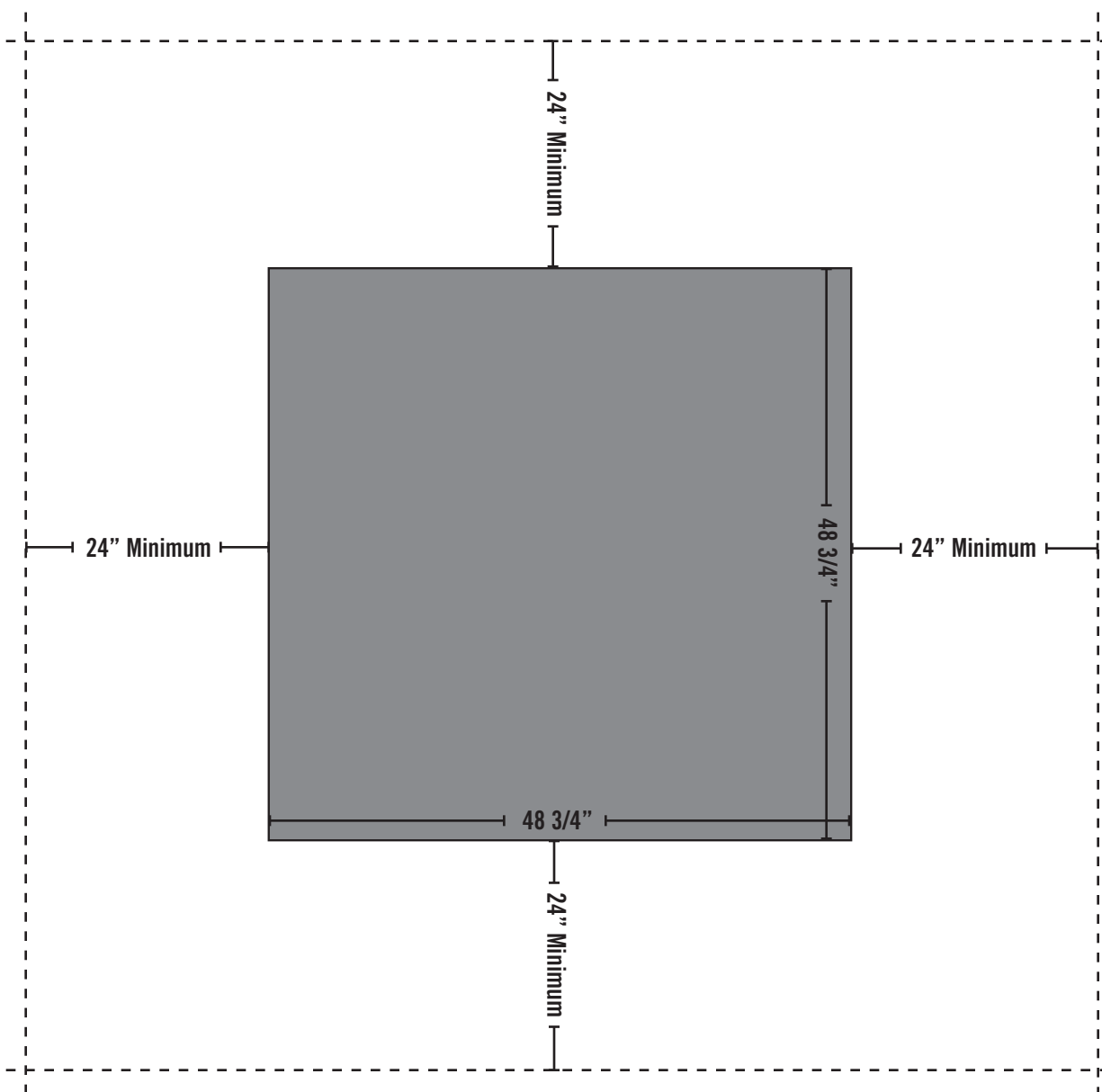

Note: The Raised Garden Bed is not recommended for placement on a patio. The organic materials used may stain the concrete.

SEC 2 RAISED GARDEN BED ASSEMBLY

SMALL PARTS REQUIRED

SMALL PARTS BAG REQUIRED: CUI

Hardware shown at actual size

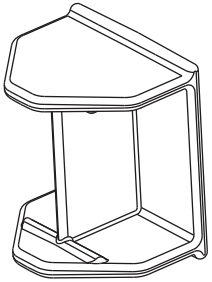

CUC (x4)
Panel Clip



CWA (x8)
Blow Hole Plug

PARTS REQUIRED

Part shown at 8% of actual size

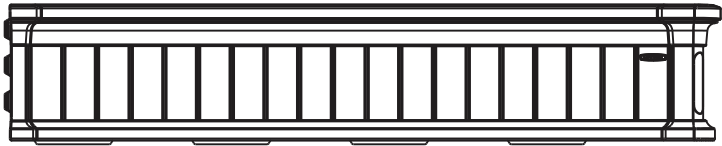

CTJ (x4)
Bed Panel

TOOLS REQUIRED

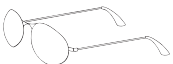

Safety Glasses



TOOLS AND SMALL PARTS REQUIRED FOR THIS PAGE

SEC 2



CWA (x8)

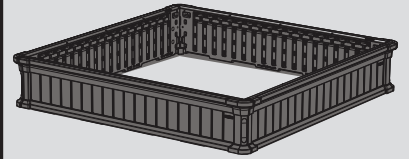

SEC

2.1

Insert a **Blow Hole Plug (CWA)** into the hole at each end of a **Bed Panel (CTJ)** as shown. **Twist the Plugs** as you insert them until they are just above the plastic of the Panel. Repeat this step for each Bed Panel.

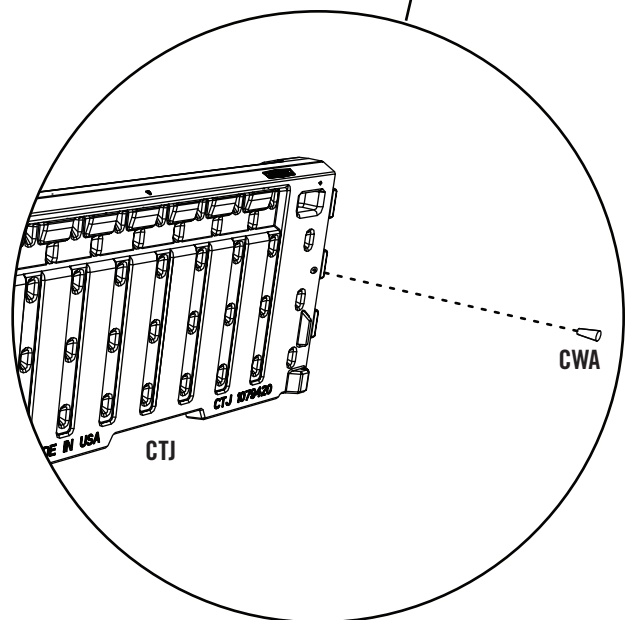
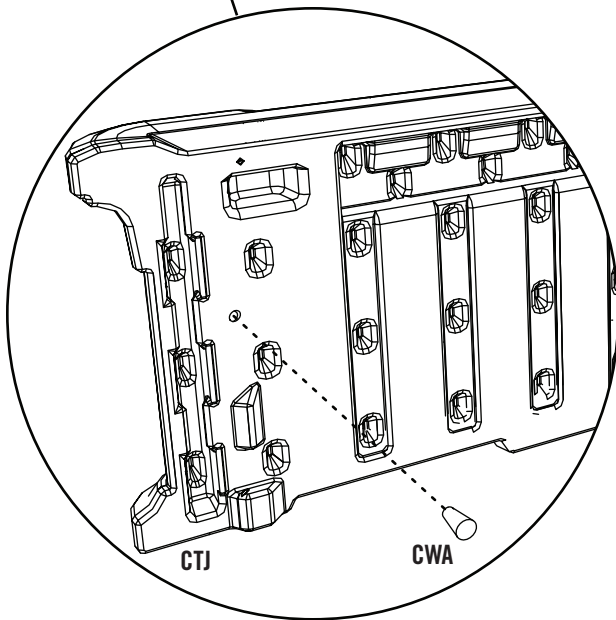
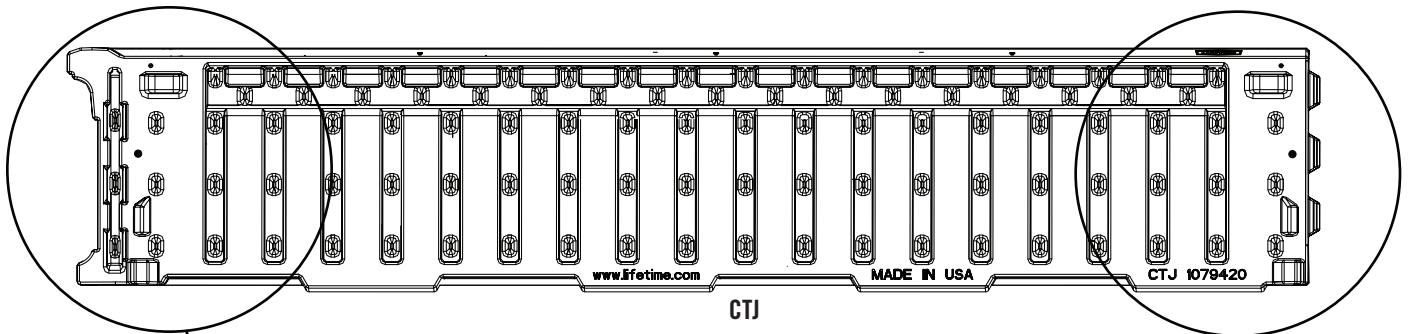



TOOLS AND SMALL PARTS REQUIRED FOR THIS PAGE

SEC. 2



NO SMALL PARTS REQUIRED FOR THIS PAGE

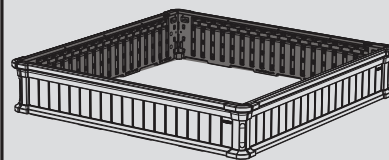

SEC

2.2

RAISED GARDEN BED ASSEMBLY

Connect two (2) Bed Panels by sliding the three tabs at the end of the 1st Bed Panel into the three slots in the end of the 2nd Panel. Then, slide the 2nd Bed Panel downward as shown.

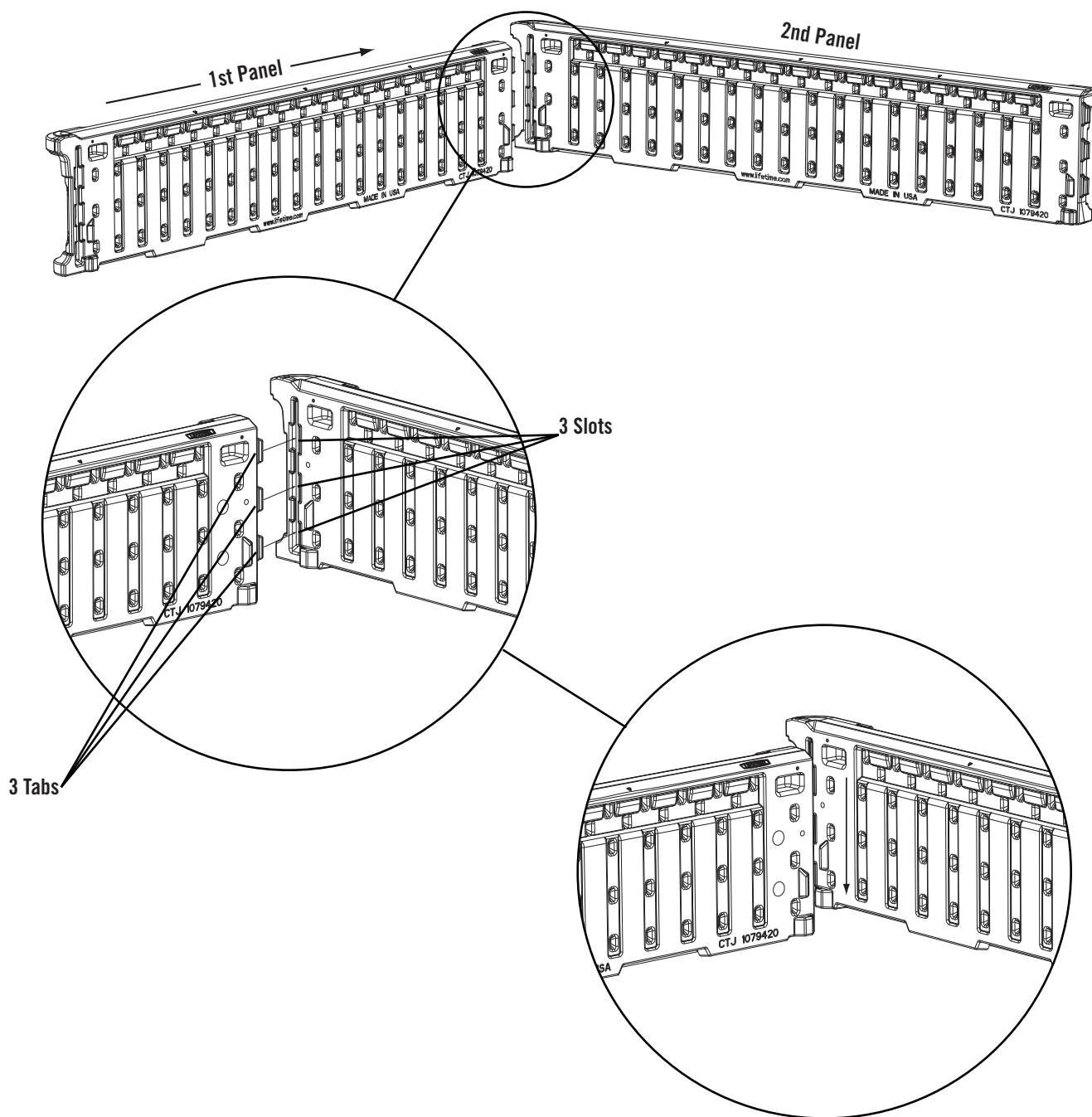



TOOLS AND SMALL PARTS REQUIRED FOR THIS PAGE

SEC 2

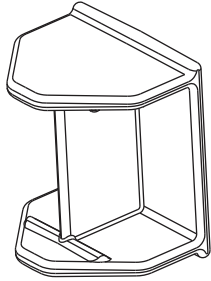

CUC (x1)

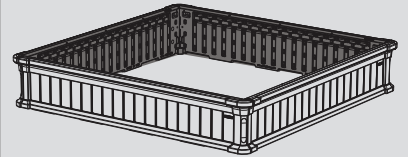

SEC

2.3

Insert a **Panel Clip (CUC)** between and over the adjacent nubs to hold the two Bed Panels together.

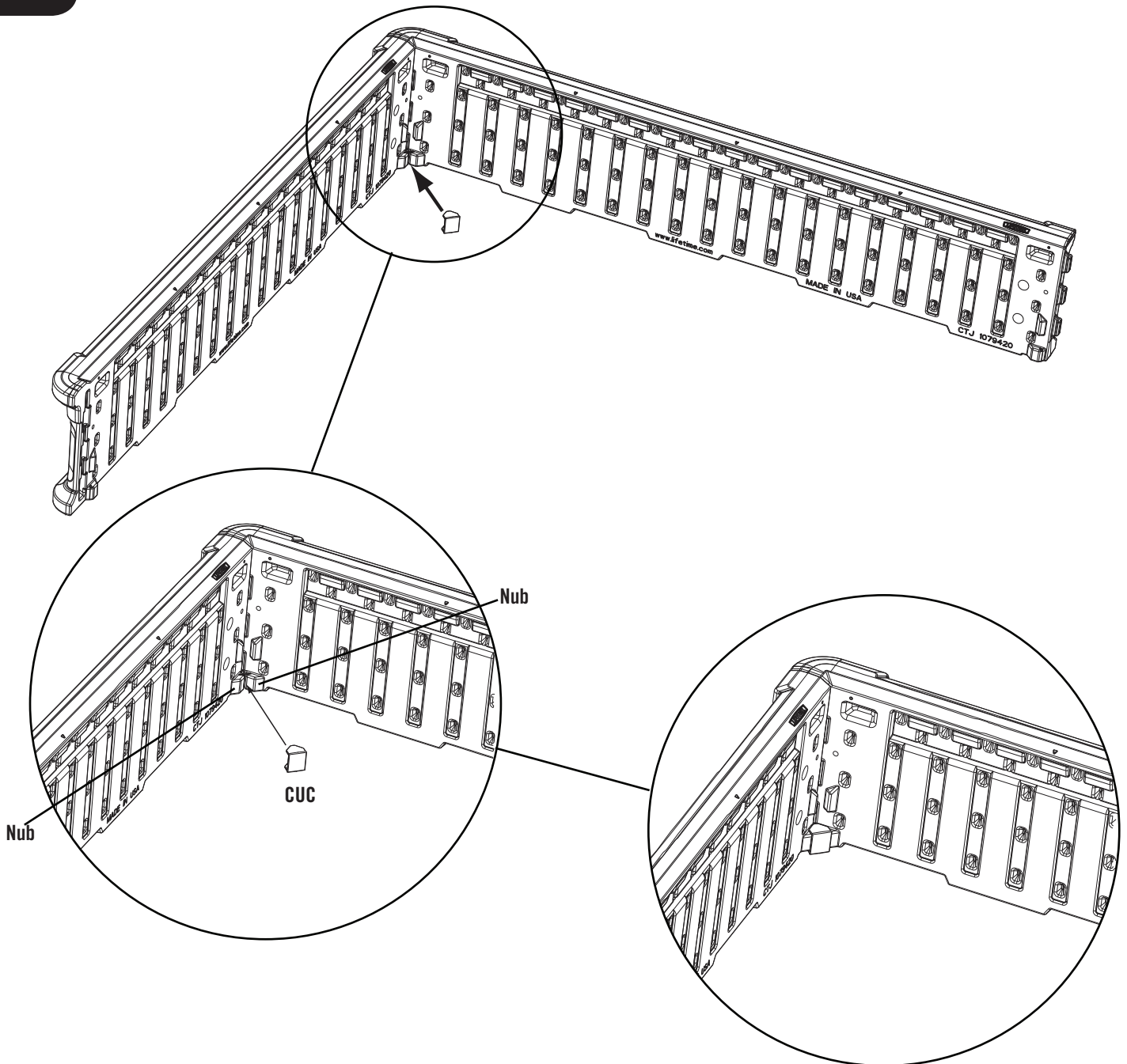



TOOLS AND SMALL PARTS REQUIRED FOR THIS PAGE

SEC 2

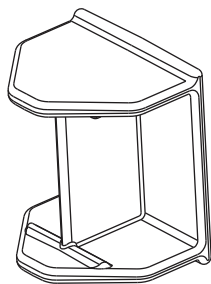

CUC (x3)

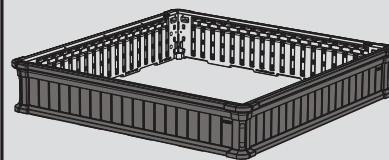

SEC

2.4

Connect the 2nd and 3rd **Bed Panels (CTJ)** in the same manner as the first two followed by a **Panel Clip (CUC)** to hold them together.

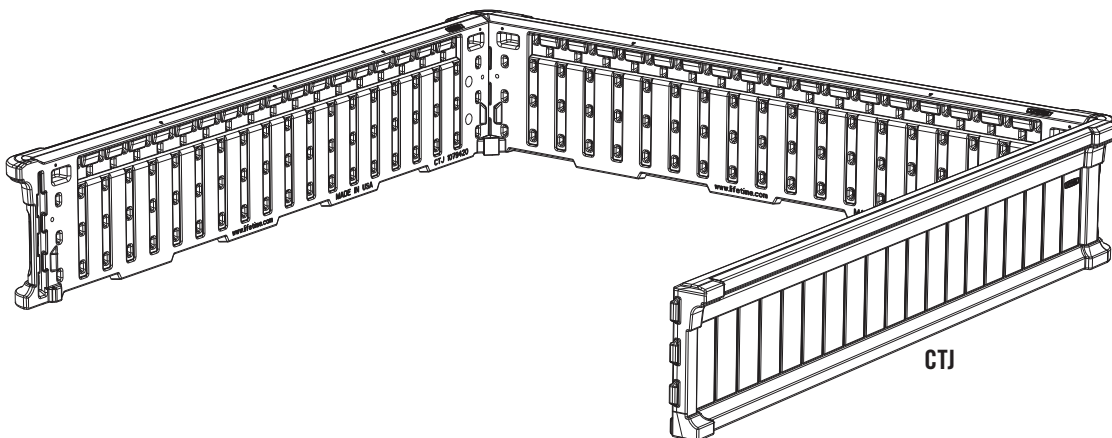

SEC

2.5

Connect the last **Bed Panel (CTJ)** to the 3rd and 1st Bed Panels in the same manner as the first two followed by a **Panel Clip (CUC)** in each corner to hold them together. Place Raised Garden Bed in desired location.

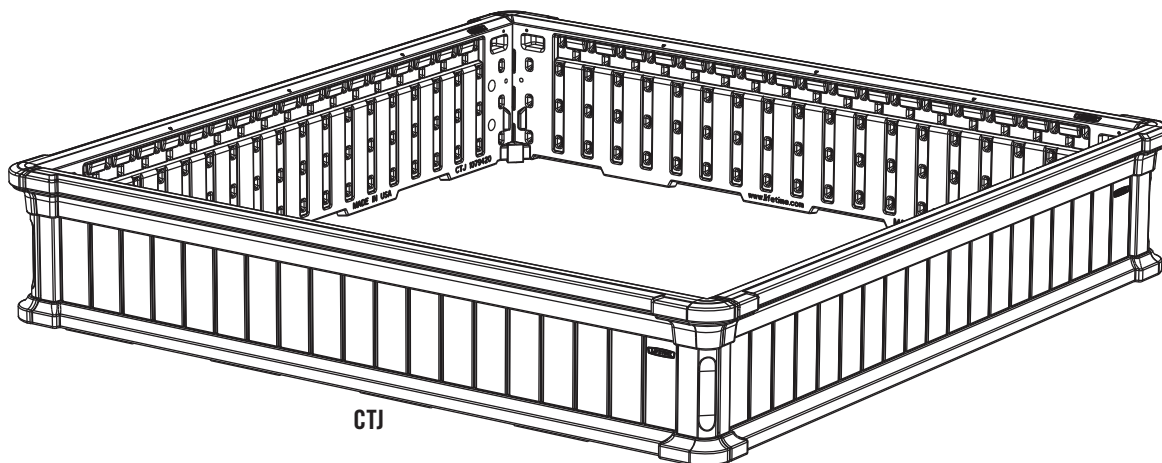

CLEANING & CARE

Congratulations on your Lifetime® product purchase. By following the instructions below, your new Lifetime product should provide you with years of service and enjoyment.

Cleaning and Care

The polyethylene panels are stain- and solvent-resistant. Most stains can be removed, using a mild soap and a soft-bristled brush. Abrasive cleaning materials may scratch the plastic and are not recommended. Repair scratches or rust spots on the metal by sanding the affected area lightly; using a rust preventative spray primer; and finally, spraying with a high-gloss spray enamel paint. Avoid placing a direct heat source on or near surfaces unless using a heat barrier.

5-YEAR LIMITED LIFETIME WARRANTY

THE MANUFACTURER RESERVES THE RIGHT TO MAKE SUBSTITUTIONS TO WARRANTY CLAIMS IF PARTS ARE UNAVAILABLE OR OBSOLETE.

1. Lifetime raised garden beds are warranted to the original purchaser to be free from defects in material or workmanship for a period of five years from the date of original retail purchase. The word “defects” is defined as imperfections that impair the use of the product. Defects resulting from misuse, abuse or negligence will void this warranty. This warranty does not cover defects due to improper installation, alteration or accident. This warranty does not cover damage caused by vandalism, rusting, “acts of nature” or any other event beyond the control of the manufacturer.
2. This warranty is nontransferable and is expressly limited to the repair or replacement of defective product. If the product is defective within the terms of this warranty, Lifetime Products, Inc. will repair or replace defective parts at no cost to the purchaser. Shipping charges to and from the factory are not covered and are the responsibility of the purchaser. Labor charges and related expenses for removal, installation or replacement of the raised garden bed or its components are not covered under this warranty.
3. This warranty does not cover scratching or scuffing of the product that may result from normal usage. In addition, defects resulting from intentional damage, negligence, unreasonable use will void this warranty.
4. Liability for incidental or consequential damages is excluded to the extent permitted by law. While every attempt is made to embody the highest degree of safety in all equipment, freedom from injury cannot be guaranteed. The user assumes all risk of injury resulting from the use of this product. All merchandise is sold on this condition, and no representative of the company may waive or change this policy.
5. This product is not intended for institutional or commercial use; Lifetime Products, Inc. does not assume any liability for such use. Institutional or commercial use will void the warranty.
6. This warranty is expressly in lieu of all other warranties, expressed or implied, including warranties of merchantability or fitness for use to extent permitted by Federal and state law. Neither Lifetime Products, Inc., nor any representative assumes any other liability in connection with this product. This warranty gives you specific legal rights, and you may also have other rights which vary from state to state.

PLEASE INCLUDE YOUR DATED SALES RECEIPT AND PHOTOGRAPHS OF DAMAGED PARTS.

REPORT PRODUCT DEFECTS IN WRITING TO:

Lifetime Products, Inc., PO Box 160010 Clearfield, UT 84016-0010
or call 1-800-225-3865 M-F 7 a.m. to 5 p.m. MST.

REGISTER YOUR PRODUCT FOR QUICKER CUSTOMER SERVICE.

Visit www.lifetime.com or call 1-800-225-3865 to register your product today.

FOR INTERNATIONAL WARRANTY CLAIMS:

All warranty claims must be accompanied by a sales receipt. Report all warranty claims in writing to your regional sales support representative. Please include your dated sales receipt and photographs of damaged parts.

To Identify the representative for your region — Please visit: www.lifetime.com/international



www.lifetime.com