

# **POWERMATIC<sup>®</sup>**

## **Operating Instructions and Parts Manual 10-inch Contractor Table Saw Model 64B**



**Powermatic**  
427 New Sanford Road  
LaVergne, Tennessee 37086  
Ph.: 800-274-6848  
[www.powermatic.com](http://www.powermatic.com)

**Part No. M-1791229**  
Revision B2 10/2018  
Copyright © 2018 Powermatic

# 1.0 Warranty and Service

Powermatic® warrants every product it sells against manufacturers' defects. If one of our tools needs service or repair, please contact Technical Service by calling 1-800-274-6846, 8AM to 5PM CST, Monday through Friday.

## Warranty Period

The general warranty lasts for the time period specified in the literature included with your product or on the official Powermatic branded website.

- Powermatic products carry a limited warranty which varies in duration based upon the product. (See chart below)
- Accessories carry a limited warranty of one year from the date of receipt.
- Consumable items are defined as expendable parts or accessories expected to become inoperable within a reasonable amount of use and are covered by a 90 day limited warranty against manufacturer's defects.

## Who is Covered

This warranty covers only the initial purchaser of the product from the date of delivery.

## What is Covered

This warranty covers any defects in workmanship or materials subject to the limitations stated below. This warranty does not cover failures due directly or indirectly to misuse, abuse, negligence or accidents, normal wear-and-tear, improper repair, alterations or lack of maintenance. Powermatic woodworking machinery is designed to be used with Wood. Use of these machines in the processing of metal, plastics, or other materials outside recommended guidelines may void the warranty. The exceptions are acrylics and other natural items that are made specifically for wood turning.

## Warranty Limitations

Woodworking products with a Five Year Warranty that are used for commercial or industrial purposes default to a Two Year Warranty. Please contact Technical Service at 1-800-274-6846 for further clarification.

## How to Get Technical Support

Please contact Technical Service by calling 1-800-274-6846. **Please note that you will be asked to provide proof of initial purchase when calling.** If a product requires further inspection, the Technical Service representative will explain and assist with any additional action needed. Powermatic has Authorized Service Centers located throughout the United States. For the name of an Authorized Service Center in your area call 1-800-274-6846 or use the Service Center Locator on the Powermatic website.

## More Information

Powermatic is constantly adding new products. For complete, up-to-date product information, check with your local distributor or visit the Powermatic website.

## How State Law Applies

This warranty gives you specific legal rights, subject to applicable state law.

## Limitations on This Warranty

POWERMATIC LIMITS ALL IMPLIED WARRANTIES TO THE PERIOD OF THE LIMITED WARRANTY FOR EACH PRODUCT. EXCEPT AS STATED HEREIN, ANY IMPLIED WARRANTIES OF MERCHANTABILITY AND FITNESS FOR A PARTICULAR PURPOSE ARE EXCLUDED. SOME STATES DO NOT ALLOW LIMITATIONS ON HOW LONG AN IMPLIED WARRANTY LASTS, SO THE ABOVE LIMITATION MAY NOT APPLY TO YOU. POWERMATIC SHALL IN NO EVENT BE LIABLE FOR DEATH, INJURIES TO PERSONS OR PROPERTY, OR FOR INCIDENTAL, CONTINGENT, SPECIAL, OR CONSEQUENTIAL DAMAGES ARISING FROM THE USE OF OUR PRODUCTS. SOME STATES DO NOT ALLOW THE EXCLUSION OR LIMITATION OF INCIDENTAL OR CONSEQUENTIAL DAMAGES, SO THE ABOVE LIMITATION OR EXCLUSION MAY NOT APPLY TO YOU.

Powermatic sells through distributors only. The specifications listed in Powermatic printed materials and on the official Powermatic website are given as general information and are not binding. Powermatic reserves the right to effect at any time, without prior notice, those alterations to parts, fittings, and accessory equipment which they may deem necessary for any reason whatsoever.

## Product Listing with Warranty Period

90 Days – Parts; Consumable items
1 Year – Motors, Machine Accessories
2 Year – Woodworking Machinery used for industrial or commercial purposes
5 Year – Woodworking Machinery

NOTE: Powermatic is a division of JPW Industries, Inc. References in this document to Powermatic also apply to JPW Industries, Inc., or any of its successors in interest to the Powermatic brand.

## 2.0 Table of contents

Section	Page
1.0 Warranty and Service.....	2
2.0 Table of contents.....	3
3.0 Safety warnings.....	4
3.1 Kickback.....	5
4.0 About this manual.....	6
5.0 Glossary.....	7
6.0 Features.....	8
7.0 Specifications.....	8
8.0 Setup and Assembly.....	10
8.1 Shipping contents.....	10
8.2 Unpacking and cleanup.....	11
8.3 Stand assembly.....	12
8.4 Mounting saw to stand.....	13
8.5 Installing handwheels/hooks.....	13
8.6 Installing table extensions.....	14
8.7 Leveling table extensions.....	14
8.8 Rails and Fence.....	14
8.9 Wood Extension Table.....	14
8.10 Switch bracket.....	15
8.11 Motor cover.....	15
8.12 Table insert.....	15
8.13 Installing and removing blade.....	15
8.14 Riving knife.....	16
8.15 Blade guard.....	16
9.0 Electrical connections.....	16
9.1 Grounding instructions.....	16
9.2 Voltage conversion.....	17
9.3 Extension cords.....	17
9.4 Switch lockout.....	18
10.0 Adjustments.....	18
10.1 Fence alignment.....	18
10.2 Blade raising/tilt mechanism.....	18
10.3 Miter gauge.....	18
10.4 Positive blade stops.....	19
10.5 Riving knife alignment.....	20
10.6 Low profile riving knife.....	20
10.7 Trunnion adjustment.....	20
10.8 Table to blade alignment.....	20
10.9 Belt tension and replacement.....	21
11.0 Operations.....	21
12.0 Safety devices.....	26
13.0 Maintenance.....	27
14.0 Optional accessories.....	28
15.0 Troubleshooting the 64B Table Saw.....	29
16.0 Replacement Parts.....	30
16.1.1 Table and Cabinet Assembly – Exploded View.....	30
16.1.2 Table and Cabinet Assembly – Parts List.....	31
16.2.1 Motor and Trunnion Assembly – Exploded View.....	32
16.2.2 Motor and Trunnion Assembly – Parts List.....	33
16.3.1 Stand Assembly – Exploded View.....	35
16.3.2 Stand Assembly – Parts List.....	35
16.4.1 Blade Guard and Miter Gauge Assemblies – Exploded View.....	36
16.4.2 Blade Guard and Miter Gauge Assemblies – Parts List.....	37
17.0 Electrical Connections.....	38
17.1 Connections for 115 volt (64B Table Saw).....	38
17.2 Connections for 230 volt (64B Table Saw).....	39



### 3.0 Safety warnings

1. Read and understand the entire owner's manual before attempting assembly or operation.
2. Read and understand the warnings posted on the machine and in this manual. Failure to comply with all of these warnings may cause serious injury.
3. Replace the warning labels if they become obscured or removed.
4. This table saw is designed and intended for use by properly trained and experienced personnel only. If you are not familiar with the proper and safe operation of a table saw, do not use until proper training and knowledge have been obtained.
5. Do not use this table saw for other than its intended use. If used for other purposes, Powermatic disclaims any real or implied warranty and holds itself harmless from any injury that may result from that use.
6. Always wear approved safety glasses/face shields while using this table saw. Everyday eyeglasses only have impact resistant lenses; they are not safety glasses.
7. Before operating this table saw, remove tie, rings, watches and other jewelry, and roll sleeves up past the elbows. Remove all loose clothing and confine long hair. Non-slip footwear or anti-skid floor strips are recommended. Do not wear gloves.
8. Always use the blade guard on all "through-sawing" operations. A through-sawing operation is one in which the blade cuts completely through the workpiece.
9. Kickback occurs when the workpiece is thrown towards the operator at a high rate of speed. If you do not have a clear understanding of kickback and how it occurs, DO NOT operate this table saw!
10. Wear ear protectors (plugs or muffs) during extended periods of operation.
11. Do not operate this machine while tired or under the influence of drugs, alcohol or any medication.
12. Make certain switch is in the OFF position before connecting machine to power supply.
13. Make certain the machine is properly grounded.
14. Make all machine adjustments or maintenance with the machine unplugged from the power source.
15. Remove adjusting keys and wrenches. Form a habit of checking to see that keys and adjusting wrenches are removed from the machine before turning it on.
16. Keep safety guards in place at all times when the machine is in use. If removed for maintenance purposes, use extreme caution and replace the guards immediately after completion of maintenance.
17. Check damaged parts. Before further use of the machine, a guard or other part that is damaged should be carefully checked to determine that it will operate properly and perform its intended function. Check for alignment of moving parts, binding of moving parts, breakage of parts, mounting and any other conditions that may affect its operation. A guard or other part that is damaged should be properly repaired or replaced.
18. Provide for adequate space surrounding work area and non-glare, overhead lighting.
19. Keep the floor around the machine clean and free of scrap material, oil and grease.
20. Keep visitors a safe distance from the work area. Keep children away.
21. Make your workshop child proof with padlocks, master switches or by removing starter keys.
22. Give your work undivided attention. Looking around, carrying on a conversation and "horse-play" are careless acts that can result in serious injury.
23. Maintain a balanced stance at all times so that you do not fall into the blade or other moving parts. Do not overreach or use excessive force to perform any machine operation.
24. Use the right tool at the correct speed and feed rate. Do not force a tool or attachment to do a job for which it was not designed. The right tool will do the job better and more safely.
25. Use recommended accessories; improper accessories may be hazardous.
26. Maintain tools with care. Keep saw blades sharp and clean for the best and safest performance. Follow instructions for lubricating and changing accessories.
27. Turn off the machine before cleaning. Use a brush or compressed air to remove chips or debris — do not use your hands.
28. Do not stand on the machine. Serious injury could occur if the machine tips over.

29. Never leave the machine running unattended. Turn the power off and do not leave the machine until it comes to a complete stop.
30. Remove loose items and unnecessary work pieces from the area before starting the machine.
31. Keep hands out of the line of saw blade.
32. Use a push-stick when required.
33. Pay particular attention to instructions on reducing risk of kickback.
34. Do not perform any operation freehand.
35. Never reach around or over saw blade.
36. Don't use in dangerous environment. Don't use power tools in damp or wet location, or expose them to rain. Keep work area well lighted.

### 3.1 Kickback

The most common accidents among table saw users, according to statistics, can be linked to kickback, the high-speed expulsion of material from the table that can strike the operator. Kickback can also result in the operator's hands being pulled into the blade.

#### Kickback Prevention

Tips to avoid the most common causes of kickback:

- Make sure the riving knife is always aligned with the blade. A workpiece can bind or stop the flow of the cut if the riving knife is misaligned, and result in kickback.
- Use a riving knife during every cut. The riving knife maintains the kerf in the workpiece, which will reduce the chance of kickback.
- Never attempt freehand cuts. The workpiece must be fed parallel to the blade, otherwise kickback will likely occur. Always use the rip fence or miter gauge to support the workpiece.
- Make sure that rip fence is parallel to blade. If not, the chances of kickback are very high.

Take the time to check and adjust the rip fence.

- Feed cuts through to completion. Anytime you stop feeding a workpiece that is in the middle of a cut, the chance of binding, resulting in kickback, is greatly increased.

#### Protection Tips from Kickback

Kickback can happen even if precautions are taken to prevent it. Listed below are some tips to protect you if kickback *does* occur:

- Stand to the side of the blade when cutting. An ejected workpiece usually travels directly in front of the blade.
- Wear safety glasses or a face shield. Your eyes and face are the most vulnerable part of your body.
- Never place your hand behind the blade. If kickback occurs, your hand will be pulled into the blade.
- Use a push stick to keep your hands farther away from the moving blade. If a kickback occurs, the push stick will most likely take the damage that your hand would have received.

 **WARNING:** This product can expose you to chemicals including cadmium, which is known to the State of California to cause cancer and birth defects or other reproductive harm. For more information go to <http://www.p65warnings.ca.gov>.

 **WARNING:** Drilling, sawing, sanding or machining wood products generates wood dust and other substances known to the State of California to cause cancer. Avoid inhaling dust generated from wood products or use a dust mask or other safeguards for personal protection.

Wood products emit chemicals known to the State of California to cause birth defects or other reproductive harm. For more information go to <http://www.p65warnings.ca.gov/wood>.

**Familiarize yourself with the following safety notices used in this manual:**



This means that if precautions are not heeded, it may result in minor injury and/or possible machine damage.



This means that if precautions are not heeded, it may result in serious injury or possibly even death.

## 4.0 About this manual

This manual is provided by Powermatic covering the safe operation and maintenance procedures for a Powermatic Model 64B Contractor Table Saw. This manual contains instructions on installation, safety precautions, general operating procedures, maintenance instructions and parts breakdown. Your machine has been designed and constructed to provide consistent, long-term operation if used in accordance with the instructions as set forth in this document.

This manual is not intended to be an exhaustive guide to table saw operational methods, use of jigs or after-market accessories, choice of stock, etc. Additional knowledge can be obtained from experienced users or trade articles. Whatever accepted methods are used, always make personal safety a priority.

If there are questions or comments, please contact your local supplier or Powermatic. Powermatic can also be reached at our web site: [www.powermatic.com](http://www.powermatic.com).

Retain this manual for future reference. If the machine transfers ownership, the manual should accompany it.



**Read and understand the entire contents of this manual before attempting assembly or operation. Failure to comply may cause serious injury.**

## 5.0 Glossary

**Arbor:** Metal shaft that connects the drive mechanism to the blade.

**Bevel Edge Cut:** Tilt of the saw arbor and blade between 0° and 45° to perform an angled cutting operation.

**Blade Guard:** Mechanism mounted over the saw blade to prevent accidental contact with the cutting edge.

**Crosscut:** Sawing operation in which the *miter gauge* is used to cut across the grain of the workpiece.

**Dado Blade:** Blade used for cutting grooves and *rabbets*. A stacked dado set can be used for wider grooves.

**Dado Cut:** Flat bottomed groove in the face of the workpiece made with a *dado blade*.

**Featherboard:** Device used to keep a board against the rip fence or table that allows the operator to keep hands away from saw blade.

**Freehand:** Moving a workpiece into the blade using only the hands, without a fixed positioning device. (This is a dangerous, unacceptable procedure – **always** use appropriate devices to feed the workpiece though the saw blade during cutting operations.)

**Kerf:** The resulting cut or gap made by a saw blade.

**Kerf, Standard:** 1/8" gap made with a standard blade.

**Kickback:** An event in which the workpiece is lifted up and thrown back toward the operator, caused when a workpiece binds on the saw blade or between the blade and rip fence (or other fixed object). To minimize or prevent injury from kickbacks, see the *Operations* section.

**Miter Gauge:** A component that controls the workpiece movement while performing a crosscut of various angles.

**Non-Through Cut:** A sawing operation that requires the removal of the *blade guard* and standard *ripping knife*, resulting in a cut that does not protrude through the top of the workpiece (includes *Dado* and *rabbit cuts*).

The blade guard and ripping knife must be re-installed after performing a non-through cut to avoid accidental contact with the saw blade during operation.

**Parallel:** Two lines or surfaces lying at equal distance from each other at every point along their lengths. For example, a rip fence must be parallel to the side face of the saw blade.

**Pawls, Anti-Kickback:** Plates with a serrated edge, usually mounted to the *splitter*, that prevent the cut workpiece being drawn back toward the blade and producing *kickback*.

**Perpendicular:** 90° (right angle) intersection or position of the vertical and horizontal planes such as the position of the saw blade (vertical) to the table surface (horizontal).

**Push Board/Push Stick:** An instrument used to safely push the workpiece through the cutting operation.

**Rabbit:** A cutting operation that creates an L-shaped channel along the edge of the board.

**Resaw:** Process of cutting a thick workpiece into thinner pieces.

**Rip Cut:** A cut made along the grain of the workpiece.

**Riving Knife:** A metal plate fixed relative to the blade, which moves with the blade as cutting depth is adjusted. Thus, it maintains not only the kerf opening in the workpiece, but also the knife-to-blade distance. A *low-profile* riving knife sits lower than the top edge of the blade, and is used for *non-through cuts*.

**Splitter (Spreader):** A stationary metal plate to which the *blade guard* is attached that maintains the *kerf* opening in the workpiece when performing a cutting operation. A splitter that rises and lowers with the blade is called a *ripping knife*.

**Straightedge:** A tool used to check that a surface is flat or *parallel*.

**Through Sawing:** A sawing operation in which the workpiece thickness is completely sawn through. Proper blade height usually allows 1/8" of the top of blade to extend above the wood stock. Keep the blade guard down, the anti-kickback pawls down, and the riving knife in place over the blade.

## 6.0 Features

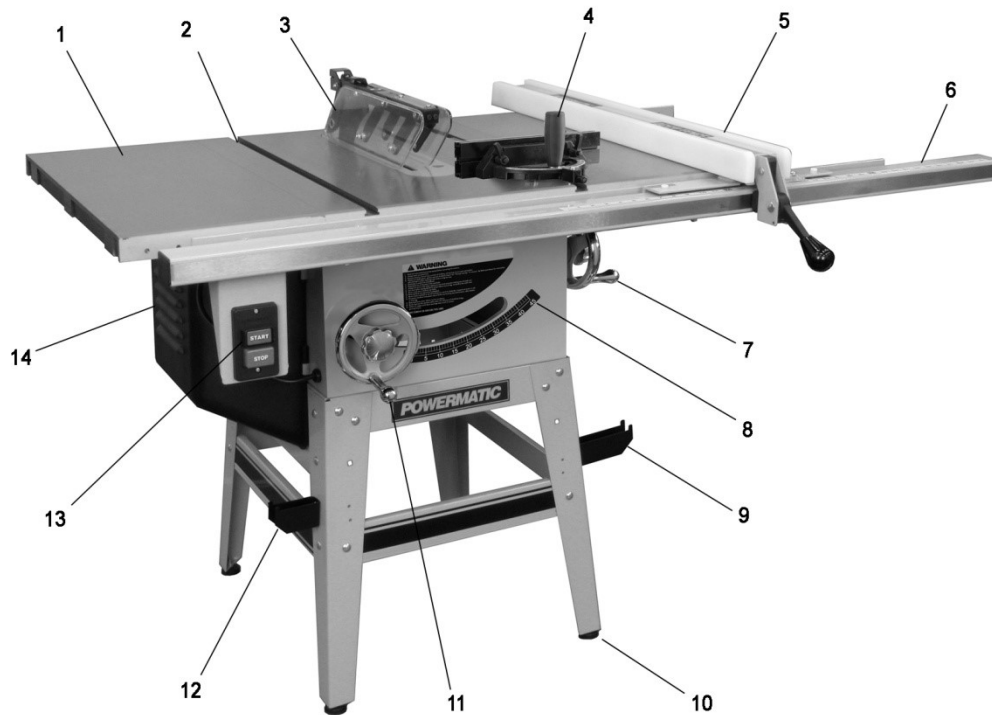

Figure 1

- |   |   |
|---|---|
| 1 – Cast iron table extensions                | 8 – Blade tilt angle scale                      |
| 2 – T-slots                                   | 9 – Accu-Fence storage hook                     |
| 3 – Transparent blade guard with riving knife | 10 – Adjustable foot pads                       |
| 4 – Precision miter gauge with extension face | 11 – Blade elevation handwheel (with lock knob) |
| 5 – Accu-Fence®                               | 12 – Miter gauge storage hook                   |
| 6 – Rail set (30" shown)                      | 13 – Industrial style push button switch        |
| 7 – Blade tilt handwheel (with lock knob)     | 14 – Motor cover                                |

## 7.0 Specifications

Model number ..... 64B

### Stock Numbers:

Model 64B basic saw – with stand, no fence or rails ..... 1791229  
 Model 64B basic saw – with 30" Rail Set, Accu-Fence®, 27"x17" Wood Extension Table ..... 1791229K  
 Model 64B basic saw – with 50" Rail Set, Accu-Fence®, 27"x36" Wood Extension Table, Legs ..... 1791230K

### Materials:

Stand ..... steel  
 Saw body ..... steel  
 Tables ..... ground cast iron  
 Handwheels ..... cast iron  
 Trunnion ..... cast iron  
 Fence body ..... steel with HDPE side plates



**Motor and Electricals:**

Motor type.....	totally enclosed fan cooled, induction, capacitor start
Horsepower.....	1-3/4 HP (1.3 kW)
Phase.....	single
Voltage.....	115/230V (prewired 115V)
Cycle.....	60 Hz
Motor speed.....	3450 RPM
Listed FLA (full load amps).....	15/7.5 A
Starting amps.....	52A
Running amps (no load).....	6A
Start capacitor.....	400MFD 125VAC
Run capacitor.....	30µF 250V
Power transfer.....	v-belt
On/off switch.....	manual industrial-style, with padlock hole
Power cord length.....	7 ft. (213cm)
Power plug installed.....	yes
Recommended circuit size <sup>1</sup> .....	30A (for 115V) or 20A (for 230V)
Noise emission:	
Without load.....	78 dB at 20 inches from blade
With load.....	85 dB at 20 inches from blade

**Arbor and blade:**

Blade Diameter <sup>2</sup> (in.).....	10" (254mm)
Arbor Diameter (in.).....	5/8" (16mm)
Arbor speed.....	3800 RPM
Arbor lock.....	yes
Maximum cut depth at 90 degrees.....	3-1/8" (79mm)
Maximum cut depth at 45 degrees.....	2-1/8" (54mm)
Maximum rip to right of blade.....	30" (762mm) or 50" (1270mm)
Maximum rip to left of blade.....	12" (305mm)
Dado maximum width.....	13/16" (20.7mm)
Dado maximum diameter.....	8" (200mm)
Blade height per one revolution of handwheel.....	5/32" (4mm) for 90°; 1/8" (2.9mm) for 45°
Blade tilt.....	left, 0 to 45°

**Table:**

Table working surface.....	20-1/8" L x 27" W (511 x 686mm)
Table working surface, with extensions.....	44-1/4" L x 27" W (1124 x 686mm)
Table working surface, with extensions and optional wood table:	
With 30" rip capacity.....	71-1/4" L x 27" W (1810 x 686mm)
With 50" rip capacity.....	80" L x 27" W (2022 x 686mm)
Table area in front of blade at maximum height.....	11-1/2" (292mm)
Table height from floor.....	36" (914mm)
Miter slot.....	two T-slots, 3/4" W x 3/8" D (19 x 10mm)
Edge bevel.....	front

**Dust collection:**

Dust port outside diameter.....	4" (100mm)
Minimum extraction volume required.....	350 cfm (9.9 cmm)

**Other:**

Stand style.....	open
Stand footprint.....	21-1/2"L x 24"W (546 x 610mm)
Overall Dimensions, shipping carton (basic saw only).....	39" L x 25" W x 22" H (98.6 x 63.6 x 56.4cm)
Overall Dimensions, fully assembled, accessories mounted:	
With 30" rip capacity.....	71-1/4" L x 43" W x 42" H (181 x 109 x 107cm)
With 50" rip capacity.....	79-5/8" L x 43" W x 42" H (202 x 109 x 107cm)

**Weights:**

Net.....	293 lb (133 kg)
Shipping.....	304 lb (138 kg)

<sup>1</sup> subject to local and national electrical codes.

<sup>2</sup> blade not included.

L=length, W=width, H=height

## 8.0 Setup and Assembly

### 8.1 Shipping contents

(Figures 2 through 7)

- 1 Saw body with switch – **A**
- 2 Cast iron table extensions – **B**
- 1 Motor cover – **C**
- 2 Handwheels – **D**
- 2 Handwheel locking knobs – **E**
- 2 Handles – **F**
- 1 Arbor wrench – **G**
- 2 Open end wrenches (14-17, 10-12mm) – **H**
- 4 Hex keys (2.5/3/4/6mm) – **I**
- 1 Blade guard with anti-kickback pawls – **J**
- 1 Riving knife – **K**
- 1 Low profile riving knife – **L**
- 1 Miter gauge – **M**
- 1 Push stick – **N**
- 1 Table insert – **O**
  
- 1 Hardware package (p/n 64B-HP):
  - 6 Hex cap screws M10x30 – **HP-1**
  - 6 Lock washers 10mm – **HP-2**
  - 6 Flat washers 10mm – **HP-3**
  
- 1 Stand assembly:
  - 1 Upper brace, with cutout – **P**
  - 1 Upper brace, long – **Q**
  - 2 Upper braces, short – **R**
  - 2 Lower braces, long – **S**
  - 2 Lower braces, short – **T**
  - 4 Legs – **U**
  - 4 Foot pads – **V**
  - 2 Fence hooks – **W**
  - 1 Miter gauge hook – **X**
  - 1 Small hook – **Y**
  
- 1 Stand hardware package (p/n 64B-SHP)
  - 4 Hex cap screws M8x25 – **SHP-1**
  - 8 Pan head screws M5x15 – **SHP-2**
  - 24 Carriage bolts M8x16 – **SHP-3**
  - 40 Flat washers 8mm – **SHP-4**
  - 28 Lock washers 8mm – **SHP-5**
  - 36 Hex nuts M8 – **SHP-6**
  - 8 Hex nuts M5 – **SHP-7**
  
- 1 Instructions and Parts Manual
- 1 Warranty Card

NOTE: The Accu-Fence, rail set, optional wood extension table and legs, are all packaged separately and supplied with their own hardware.

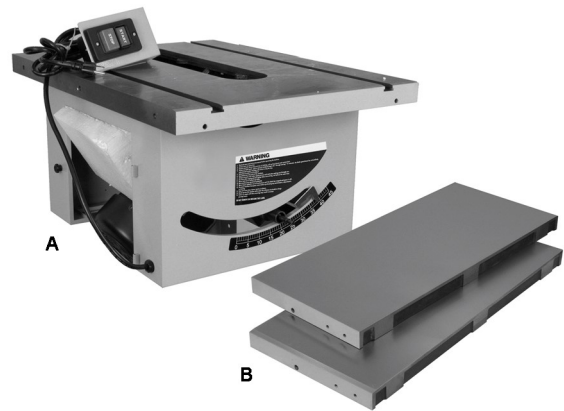

Figure 2

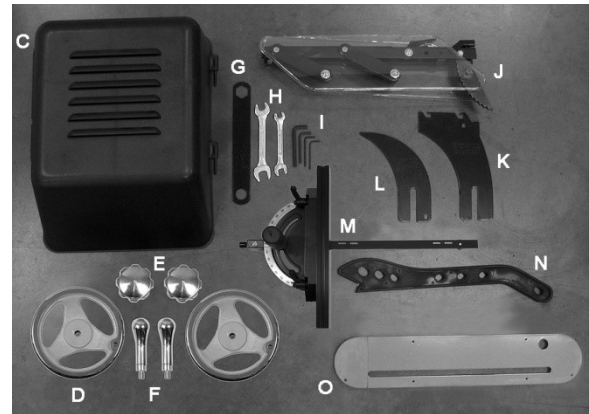

Figure 3



Figure 4 – Hardware package (64B-HP)

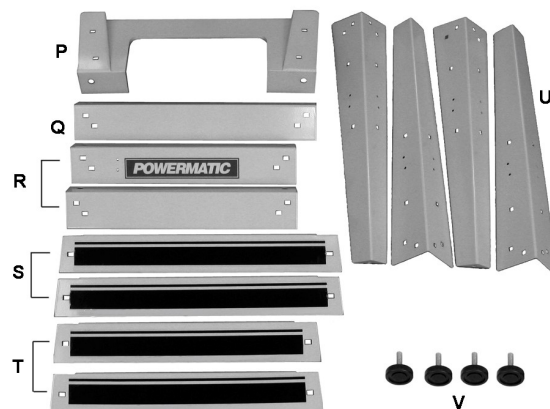

Figure 5 – Stand assembly

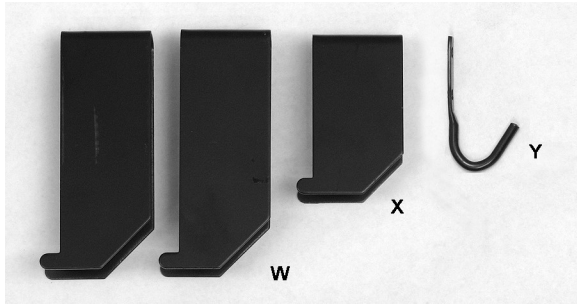

Figure 6

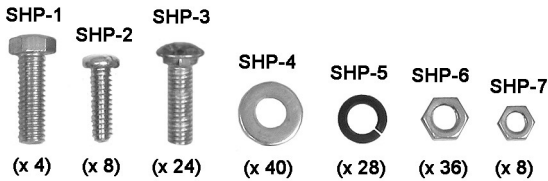

Figure 7 – Stand hardware package (64B-SHP)

## 8.2 Unpacking and cleanup

Open shipping container and check for shipping damage. Report any damage immediately to your distributor and shipping agent. Do not discard any shipping material until the Table Saw is assembled and running properly.

Compare the contents of your container with the previous list to make sure all parts are intact. Missing parts, if any, should be reported to your distributor. Read the instruction manual thoroughly for assembly, maintenance and safety instructions.

### Tools required for assembly (provided):

10, 12, 14 and 17 mm wrenches  
Hex key set  
Arbor wrench

### Additional tools required (not supplied):

Cross point screwdriver  
Rubber mallet or dead-blow hammer (or steel hammer over a block of wood)

### 8.3 Stand assembly

Assembly tip: A ratchet wrench with sockets and extensions will speed assembly time.

1. Assemble stand, using Figure 8 as a guide. Use the provided carriage bolts, flat washers, lock washers, and hex nuts (SHP-3/4/5/6).

**Only make fasteners snug at this time.** They will be fully tightened later, after stand has settled under the weight of the saw.

2. Note the orientation of the cut-out brace (P) to the front brace with Powermatic label (R). The cut-out brace must be to the left, to allow protrusion of the motor.

3. When stand has been assembled, turn it over and install the rubber foot pads (V). (Should you ever need height adjustment on the foot pad, loosen the two hex nuts, rotate the pad, then retighten the hex nuts against the metal of the stand.)
4. Turn stand right-side up. The fasteners are not fully tight, but they should be snug enough to withstand the weight of the saw. If the stand needs more stability, snug fasteners a little more.
5. The four large holes on top of the stand should be reasonably aligned through the upper braces for easy insertion of the screws.

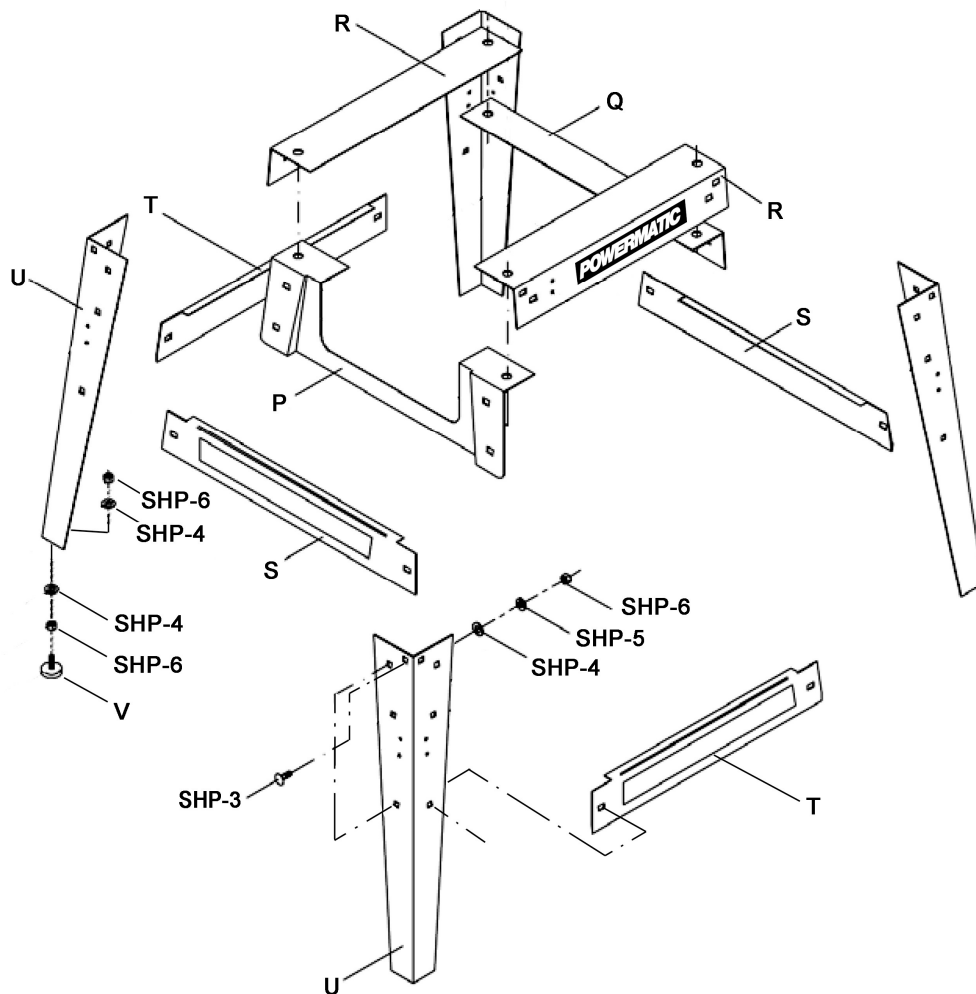

Figure 8

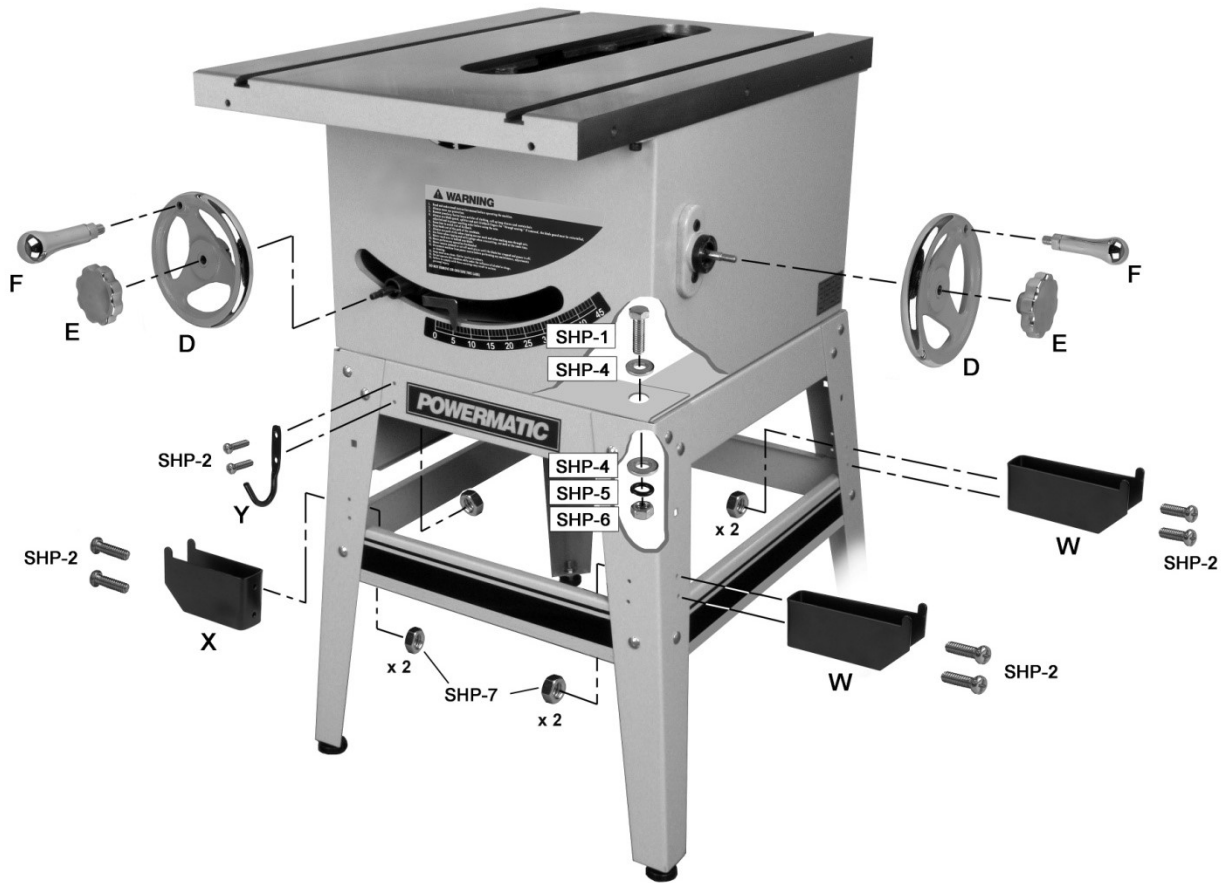

Figure 9

## 8.4 Mounting saw to stand

Refer to Figure 9

**⚠ WARNING** The table saw is heavy! Get persons to assist you in lifting it. Failure to comply may result in serious personal injury and/or damage to the machine.

1. Carefully lift table saw out of carton.
2. Place table saw atop the stand, orienting the motor in the cut-out of the stand, and aligning the four holes on its bottom edge with those in the stand.
3. Insert four screws, with flat washers, lock washers and hex nuts (SHP-1/4/5/6), as shown.
4. Securely tighten all four hex nuts (SHP-6), using a 12mm wrench and an additional wrench to hold the screw steady while tightening the nut. (NOTE: If you need more room to wrench the back screws, follow instructions below for tilting motor out of the way.)
5. Finish tightening all fasteners in the stand.

## 8.5 Installing handwheels/hooks

Refer to Figure 9.

1. Install a handwheel onto the tilting and raising shafts, as shown. Fit the slot of the handwheel onto the roll pin on the shaft, then secure by screwing on the locking knob.
2. Install a handle onto each handwheel, using a 14mm wrench on the flat to tighten it.
3. Install hooks (W and X) with two screws and hex nuts (SHP-2/7). Placement is personal preference, as all legs have holes for them.  
NOTE: The two larger hooks will be on the same side, to hold the fence. The smaller hook holds the miter gauge.
4. Mount small hook (Y) to the front, to hold additional accessories such as arbor wrench, push stick, riving knife, etc.
5. Tilt arbor using right handwheel, and remove Styrofoam packing from above motor.

## 8.6 Installing table extensions

Refer to Figure 10.

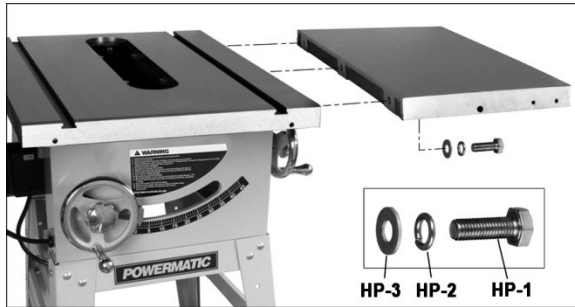

Figure 10

1. Attach a table extension to the saw table. *Make sure edge bevel on table extension faces front, to match that of saw table.* Use three screws, lock washers and flat washers (HP-1/2/3). Lightly snug screws with 17mm wrench.

**Assembly Tip:** If you are doing this without an assistant, lift table extension *vertically* to the table edge. Install center screw and washer, and make snug. Then pivot the extension parallel to saw table to insert the other two screws.

2. Repeat for opposite table extension. Lightly snug screws.
3. The front edge of table extensions must be flush with front edge of saw table. If needed, tap front edge of extension with a rubber mallet to make flush. See Figure 11.

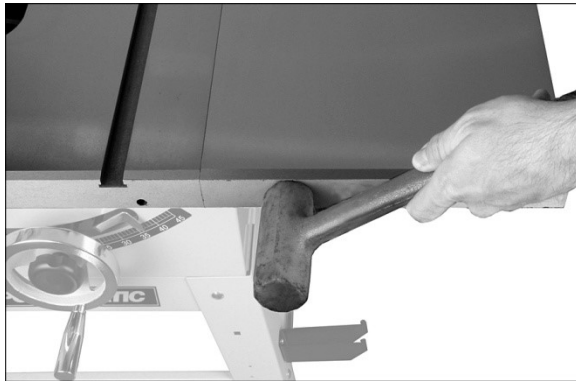

Figure 11

## 8.7 Leveling table extensions

Refer to Figure 12.

Level table extensions to saw table using a straight edge. A metal straight edge is ideal, though a carefully jointed board may also be used.

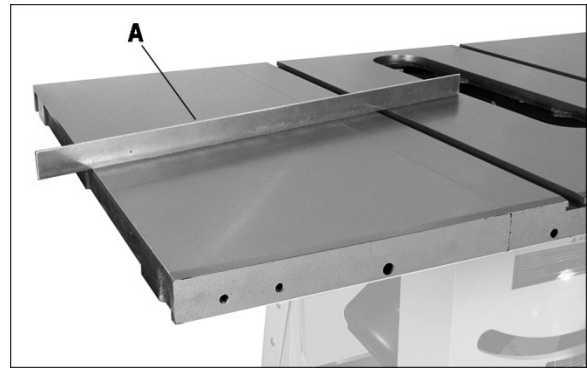

Figure 12

1. Start by tightening the three screws (17mm wrench) under the table extension that secure it to the saw table. Tighten these just enough to hold the extension in place but loose enough to change the extension height by tapping on it.
2. Lay the straight edge (A, Figure 12) across the saw table and extension, extending it out past the edge of the extension as shown.
3. Move the straight edge to several places along the table extension, as you continue to nudge the extension level with the saw table. When extension is level with saw table, securely tighten each of the three screws.
4. Repeat steps 1 through 3 for opposite table extension.

## 8.8 Rails and Fence

With table extensions properly aligned, the rails and Accu-Fence® assembly can now be mounted to the saw. Consult the manual, no. M-2195075Z, that accompanies the fence.

**NOTE:** The two tapped holes at the ends of the table extensions are not used. There may be additional holes in the table's edge that are not required for this rail installation.

## 8.9 Wood Extension Table

For instructions on mounting the accessory wood extension table, consult your Accu-Fence® manual, document no. M-2195075Z.

## 8.10 Switch bracket

Refer to Figure 13.

Remove existing screw and washers from the farthest left hole on the guide tube, and use them to secure the control switch to bottom of guide tube, as shown in Figure 13 (10mm wrench).



Figure 13

## 8.11 Motor cover

Refer to Figure 14.

1. At the motor side, slide the hinge pins of the motor cover down into the cylinders.
2. To secure cover, loosen knob (B), and swing cover shut, while pushing in on the side. The slot (C) should slide beneath the knob.
3. Tighten knob (B).



Figure 14

## 8.12 Table insert

Refer to Figure 15.

Place insert into table opening (the finger hole is toward front of saw). Verify that insert lies flush with table surface by resting a straight edge across it at various points. If insert is not flush along its length, turn any of six set screws (D) to raise or lower that area of the insert.

NOTE: If while lowering blade, the points on the anti-kickback pawls tend to catch in the seam between table and table insert, slightly raise that area of the table insert above main table surface.

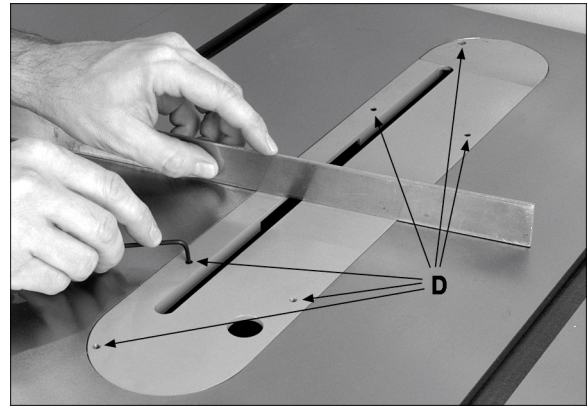

Figure 15

## 8.13 Installing and removing blade

A blade is not provided with the 64B.

1. Using front handwheel, raise blade arbor fully and tighten lock knob.

Refer to Figures 16 and 17.

2. Remove *nut* (A) and *flange* (B), and install blade onto arbor, making sure the teeth point downward toward front of saw.
3. Install *flange* (B) and *nut* (A).
4. Rotate arbor until hole (C, Figure 17) aligns with *arbor lock pin* (D). Push tab (E) to seat pin into hole, and hold to prevent blade rotation.
5. Tighten nut (A) with arbor wrench.
6. Release arbor lock (E).

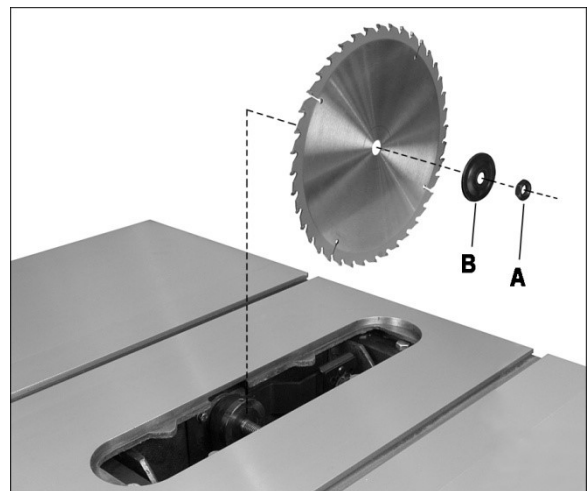

Figure 16

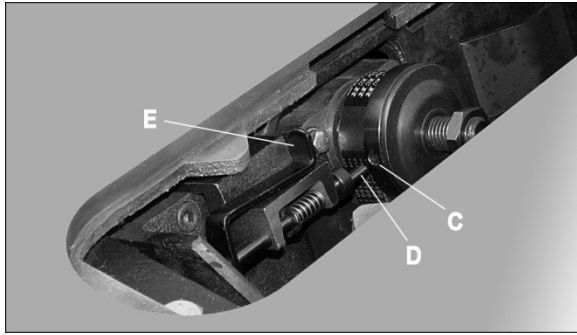

Figure 17

### 8.14 Riving knife

Refer to Figure 18.

The saw is supplied with two riving knives: One extends above the blade and accepts the blade guard; the other is a low-profile knife that acts alone for non-through cutting.

To install a riving knife:

1. Remove table insert, and raise arbor all the way up.
2. Slide prongs of riving knife into slot between block (F, Figure 18) and plate (G), and push riving knife down as far as it will go.
3. Push lever (H) downward, toward blade, until tight.
4. The riving knife must be parallel to saw blade. See section 10.5.

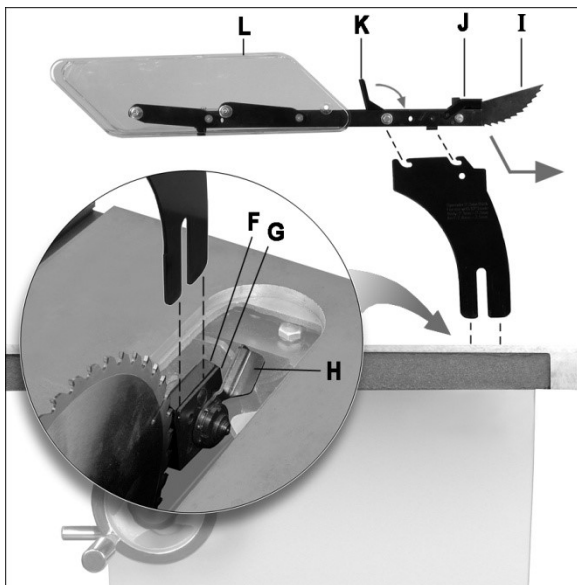

Figure 18

### 8.15 Blade guard

Refer to Figure 18.

1. Lift the anti-kickback pawls (I) and secure them with the latch (J).

2. Push guard down so that the pins slide into the slots in the riving knife, then pull guard backward to seat.
3. Secure with top latch (K).
4. The transparent guard leaves (L) should drop freely to the table.
5. Lift the latch (J) to free the pawls. *Pawls must be lowered into operating position before using the saw!*

## 9.0 Electrical connections

**⚠WARNING** Electrical connections must be made by a qualified electrician in compliance with all relevant codes. This machine must be properly grounded to help prevent electrical shock and possible fatal injury.

The 64B table saw is rated at 115/230V power, and is pre-wired for 115 volt. The table saw comes with a plug designed for use on a circuit with a *grounded outlet* that looks like the one pictured in A, Figure 19.

Before connecting to power source, be sure switch is in *off* position.

It is recommended that the table saw, when operated on **115 volt power**, be connected to a dedicated 30 amp circuit with a 30 amp circuit breaker or time-delay fuse marked "D". When operated on **230 volt power**, it is recommended that the table saw be connected to a dedicated 20 amp circuit with a 20 amp circuit breaker or time-delay fuse marked "D". **Local codes take precedence over recommendations.**

### 9.1 Grounding instructions

1. *All Grounded, Cord-connected Tools:*

In the event of a malfunction or breakdown, grounding provides a path of least resistance for electric current to reduce the risk of electric shock. This tool is equipped with an electric cord having an equipment-grounding conductor and a grounding plug. The plug must be inserted into a matching outlet that is properly installed and grounded in accordance with all local codes and ordinances.

Do not modify the plug provided - if it will not fit the outlet, have the proper outlet installed by a qualified electrician.

Improper connection of the equipment-grounding conductor can result in a risk of electric shock. The conductor with insulation having an outer surface that is green with or without yellow stripes is the equipment-grounding conductor.



If repair or replacement of the electric cord or plug is necessary, do not connect the equipment-grounding conductor to a live terminal.

Use only 3-wire extension cords that have 3-prong grounding plugs and 3-pole receptacles that accept the tool's plug.

Repair or replace damaged or worn cord immediately.

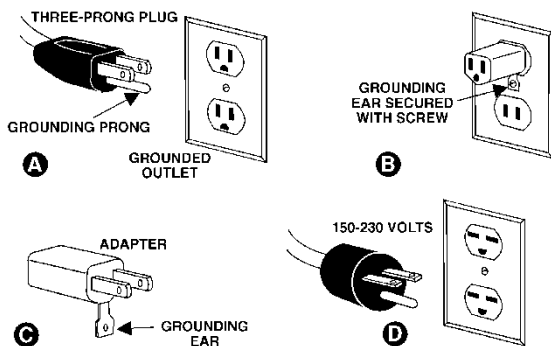

Figure 19

2. *Grounded, cord-connected tools intended for use on a supply circuit having a nominal rating less than 150 volts:*

This tool is intended for use on a circuit that has an outlet that looks like the one illustrated in **A**, Figure 19. An adapter, shown in **B** and **C**, may be used to connect this plug to a 2-pole receptacle as shown in **B** if a properly grounded outlet is not available. The temporary adapter should be used only until a properly grounded outlet can be installed by a qualified electrician. *This adapter is not permitted in Canada.* The green-colored rigid ear, lug, and the like, extending from the adapter must be connected to a permanent ground such as a properly grounded outlet box.

3. *Grounded, cord-connected tools intended for use on a supply circuit having a nominal rating between 150 - 250 volts, inclusive:*

This tool is intended for use on a circuit that has an outlet that looks like the one illustrated in **D**, Figure 19. The tool has a grounding plug that looks like the plug illustrated in **D**. Make sure the tool is connected to an outlet having the same configuration as the plug. No adapter is available or should be used with this tool. If the tool must be reconnected for use on a different type of electric circuit, the reconnection should be made by qualified service personnel; and after reconnection, the tool should comply with all local codes and ordinances.

**⚠ WARNING** Check with a qualified electrician or service personnel if the grounding instructions are not completely understood, or if in doubt as to whether the tool is properly grounded. Failure to comply may cause serious or fatal injury.

## 9.2 Voltage conversion

If 230V single phase operation is desired, follow these instructions:

1. Disconnect table saw from power source.
  2. Open the motor junction box, and consult the diagram on the inside of the junction box cover. Similar diagrams are shown in *section 17.0*.
- NOTE: In case of discrepancy, the junction box label takes precedence.
3. The four motor leads are connected for 115V operation; reconnect these leads for 230V operation, as shown in the diagrams.
  4. The 115 volt attachment plug, supplied with the saw, must be replaced with a UL/CSA listed plug suitable for 230 volt operation. Consult an electrician for proper procedures to install the plug. The saw must comply with all local and national codes after the 230 volt plug is installed.

**In all cases (115V or 230V) make certain the receptacle in question is properly grounded. If you are not sure, have a registered electrician check the receptacle.**

## 9.3 Extension cords

USE PROPER EXTENSION CORD. Make sure your extension cord is in good condition. When using an extension cord, be sure to use one heavy enough to carry the current your product will draw. An undersized cord will cause a drop in line voltage resulting in loss of power and overheating. Table 1 shows correct size to use depending on cord length and nameplate ampere rating. If in doubt, use the next heavier gauge. The smaller the gauge number, the heavier the cord.

Ampere Rating		Volts	Total length of cord in feet			
More Than	Not More Than	120	25	50	100	150
		240	50	100	200	300
			AWG			
0	6		18	16	16	14
6	10		18	16	14	12
10	12		16	16	14	12
12	16		14	12	Not Recommended	

Extension Cord Recommendations  
Table 1

## 9.4 Switch lockout

The table saw is equipped with a push-button switch that will accept a safety padlock, as shown in Figure 20. To safeguard your machine from unauthorized operation and accidental starting by young children, the use of a padlock (not included) is highly recommended. Place the key in a location that is inaccessible to children and others not qualified to use the tool.

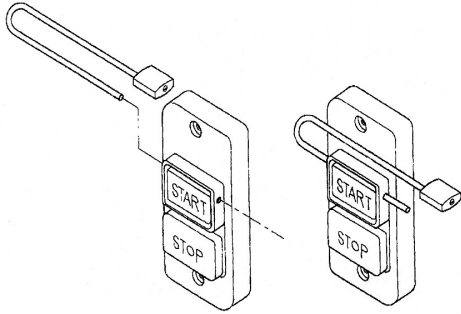

Figure 20: Switch Lock Out

## 10.0 Adjustments

### 10.1 Fence alignment

Before using the Accu-Fence®, verify that it is properly aligned with the blade. Consult the manual, no. M-2195075Z, that accompanied the fence.

### 10.2 Blade raising/tilt mechanism

**CAUTION** Do not try to force tilting mechanism past the 45° or 90° stops. This may cause blade to go out of alignment.

Refer to Figure 21:

To raise or lower blade, loosen *lock knob* (A) and turn *handwheel* (B) on front of saw until desired height is reached. Tighten lock knob. The blade should be adjusted about 1/8" above top surface of material being cut.

To tilt blade, turn *lock knob* (C) counter-clockwise to loosen, turn *handwheel* (D) until desired angle is obtained, and retighten *lock knob* (C).



Figure 21

## 10.3 Miter gauge

Refer to Figure 22.

### 10.3.1 Setting miter angle

The precision miter gauge has a rack and pinion adjustment for setting the angle. To operate:

1. Slide miter gauge into one of the slots on table top.
2. Loosen *lock handle* (A, Figure 22) by turning counterclockwise.
3. Pull out spring-loaded *knob* (C) and rotate knob until *body* (B) of miter gauge is at the desired angle as indicated on the scale.
4. Tighten *lock handle* (A).

### 10.3.2 Indent settings

There are indents at the 0°, 30° and 45° right and left positions. At these settings, release *knob* (C) to engage stop rod. Then tighten *lock handle* (A).

**Note:** Do not rely solely on the indents for an accurate setting. After the stop rod engages at the 0°, 30° and 45° positions, make a fine adjustment with the *knob* (C) if necessary, setting it against the *scale indicator* (G).

### 10.3.3 Extension plate

The *extension plate* (D, Figure 22) can be adjusted by sliding to the right or left or removed entirely.

To adjust, loosen two *lock handles* (E), position the extension plate and retighten lock handles. **Make sure end of extension plate is not in the blade's path.**

NOTE: The lock handles (E) are adjustable. Pull out on a handle, rotate it to different position, then release, making sure it seats itself upon the pin.

To remove extension plate, slide it completely off and remove lock handles (E) and mounting hardware.

### 10.3.4 Calibration

1. Place miter gauge in one of the slots on the table top.
2. Set miter gauge at 90° to blade (0° setting on the scale) by loosening lock handle (A), then pulling out spring-loaded knob (C) and turning the body (B) until 0° is indicated on scale.
3. Measure the accuracy of the gauge against the slot with a combination square.

If adjustment is necessary:

4. Adjust body (B) until it is perfectly square (90°) to miter slot.
5. Tighten lock handle (A).
6. Verify that *scale indicator* (G) reads 0°. If further adjustment is needed:

7. Loosen screw (F) and adjust *indicator* (G) until it reads 0°.
8. Tighten screw (F).

NOTE: The bar of the miter gauge has two slots with *set screws* (H). Adjust these set screws (4mm hex key) to eliminate any play between bar and miter slot.

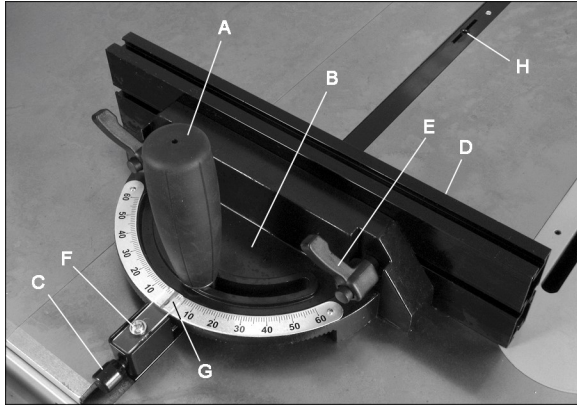

Figure 22

## 10.4 Positive blade stops

The stops for 90°, 45° blade tilt, and elevation settings have all been factory set, and should require no immediate adjustment. The settings should be confirmed by the operator, however, and especially if cuts become inaccurate.

### 10.4.1 90° Blade stop

1. Disconnect machine from power source.
2. Make sure table insert has been leveled with table surface. See *section 8.12*.
3. Raise blade all the way, and place a 90° square on the table and against the blade (Figure 23). Make sure that a blade tooth does not obstruct the actual reading.
4. Tilt blade with handwheel as needed until square and blade are flush.
5. If adjustment is required, loosen the two setscrews on 90° stop collar (A, Figure 25 – 3mm hex key) and rotate collar along the lead screw to needed position. Verify the new setting.
6. Loosen screw on pointer (B, Figure 25), and adjust pointer to zero. Retighten screw.

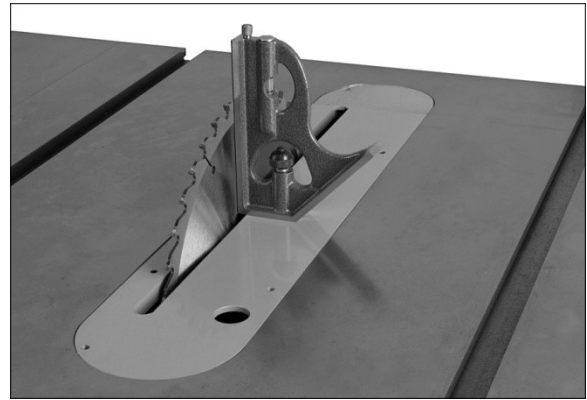

Figure 23

### 10.4.2 45° Blade stop

Repeat steps 1 through 4 above for 45° setting, as shown in Figure 24. The 45° stop is shown at C, Figure 25.

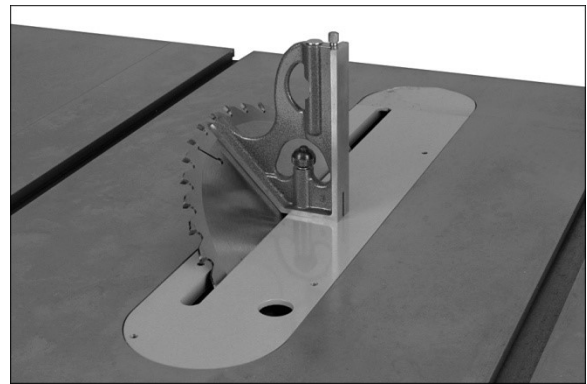

Figure 24

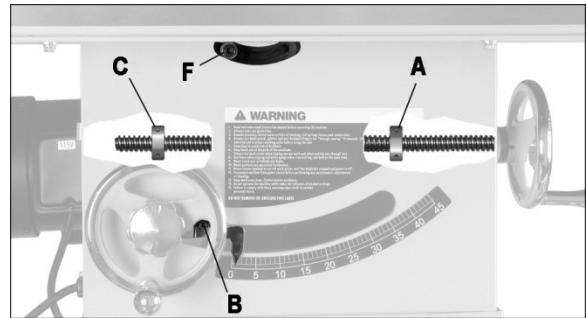

Figure 25

### 10.4.3 Blade elevation stops

Lower blade all the way; it should drop completely below the table surface. If it does not, adjust amount of drop using two stop screws (D, Figure 26).

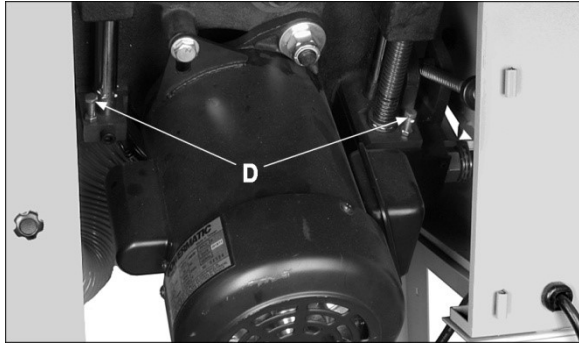

Figure 26

## 10.5 Riving knife alignment

The riving knife must be aligned with the blade for proper and safe operation of the table saw. This has been set by the manufacturer, but should be verified by the operator.

1. Disconnect machine from power source.
2. Install riving knife and tighten lever (H, Figure 18).
3. Place a straight edge against blade and riving knife; it should lie flush against both surfaces. See Figure 27.
4. If correction is needed, remove straight edge, table insert, and riving knife and locate four set screws (E, Figure 28) through the corner holes of clamp block.
5. Rotate any of the four set screws as needed to tilt the angle of the clamp block, and thus the riving knife.
6. Install riving knife and verify the setting with the straight edge. Make further adjustments as needed.

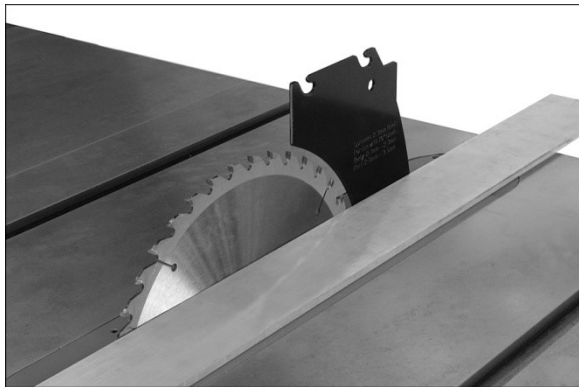

Figure 27

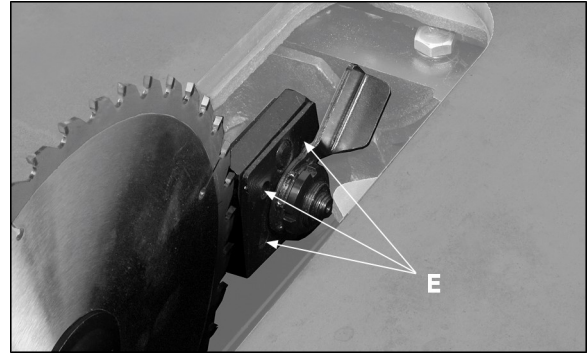

Figure 28

## 10.6 Low profile riving knife

A low profile riving knife is included with your saw. It mounts and adjusts in the same manner as the standard riving knife. The low profile riving knife sits just below top of blade and is used for making non-through cuts. *The blade guard is not used with this knife, so extra precautions should be taken during operation.*

## 10.7 Trunnion adjustment

If backlash develops in the trunnion assembly, it can be adjusted out using the screws (6mm hex key) at front and back of cabinet (F, Figure 25 shows front screw). Front and rear trunnions should receive the same amount of spring tension from the screws.

## 10.8 Table to blade alignment

Refer to Figures 29 and 30.

The table has been squared to the blade by the manufacturer and no adjustment is necessary now. If cuts become inaccurate, check table-blade squareness and correct if necessary. Use the miter slot to do this:

1. Disconnect saw from power source.
2. Raise blade to maximum height.
3. Mark one tooth (A, Figure 29) with a grease pencil and position the tooth slightly above the top edge of table at the front.
4. Raise the miter gauge slightly out of its slot to serve as a shoulder. Using a sliding square (B) against the side of the bar, slide the scale over until it touches the tip of the blade, and lock the scale in position.

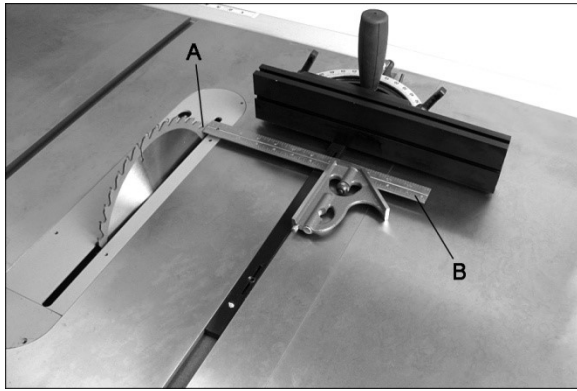

Figure 29



Figure 30

5. Rotate marked tooth (A) so that it is slightly above table top at the rear and, using the square as before, verify that the distance to the blade is the same. See Figure 30. If the distances are not the same, make a careful note of the difference.
6. Loosen table screws (item #30, section 16.1.1), and nudge table according to the distance you noted.
7. Retighten screws firmly.
8. Verify the alignment, angle pointer setting, fence setting, etc. Make any needed adjustments.

### 10.9 Belt tension and replacement

Tension of the drive belt should be inspected after the first few days of operation, as it may stretch slightly during initial use; also inspect it periodically thereafter.

To tighten belt:

1. Disconnect machine from power source.
2. Loosen screw (A, Figure 31) and hex nut (B, Figure 31).
3. Press down on motor while retightening screw (A) and hex nut (B).

If belt shows signs of wear, fraying, cracks, etc. it should be replaced:

1. Loosen screw (A) and hex nut (B) and pivot motor upward to release tension on belt. If greater movement is needed, remove screw (A) and pivot motor further.
2. Replace belt.
3. Reinstall screw (A) and push down on motor to tension new belt.
4. Tighten screw (A) and hex nut (B).



Figure 31

## 11.0 Operations

**NOTE:** If the saw is to be used without the metal stand provided, care must be taken to provide a hole in the stand or bench used by the operator to facilitate removal of sawdust.

**CAUTION** If there is any tendency to slide, walk, or tip over during operation, the stand or bench **MUST** be secured to the floor.

Familiarize yourself with the location and operation of all controls and adjustments and the use of accessories such as miter gauge and rip fence.

### 11.1 Start/stop switch

**CAUTION** This table saw has a manual switch. If the power goes out during operation, push the STOP button. Otherwise, the saw will start up when power is restored.

### 11.2 Kickback prevention

Serious injury can result from kickbacks which occur when a workpiece binds on the saw blade or binds between the blade and rip fence or other fixed object. This binding can cause the workpiece to lift up and be thrown toward the operator.

Listed below are conditions which can cause kickbacks:

- Confining the cutoff piece when crosscutting or ripping.

- Releasing the workpiece before completing operation or not pushing work piece all the way past saw blade.
- Not using the splitter/riving knife when ripping or not maintaining alignment of the splitter/riving knife with the saw blade.
- Using a dull saw blade.
- Not maintaining alignment of the rip fence so that it tends to angle toward rather than away from the saw blade front to back.
- Applying feed force when ripping to the cutoff (free) section of the workpiece instead of the section between saw blade and fence.
- Ripping wood that is twisted (not flat), or does not have a straight edge, or has twisted grain.

To minimize or prevent injury from kickbacks:

- Avoid conditions listed above.
- Wear a safety face shield, goggles, or glasses.
- Do not use the miter gauge and rip fence in the same operation unless provision is made by use of a facing board on the fence so as to allow the cutoff section of the workpiece to come free before the actual cut begins (See Figure 39).
- As the machine receives use, the operation of the anti-kickback pawls should be checked periodically (Figure 32). If the pawls do not stop the reverse motion of a workpiece, resharpen all the points.

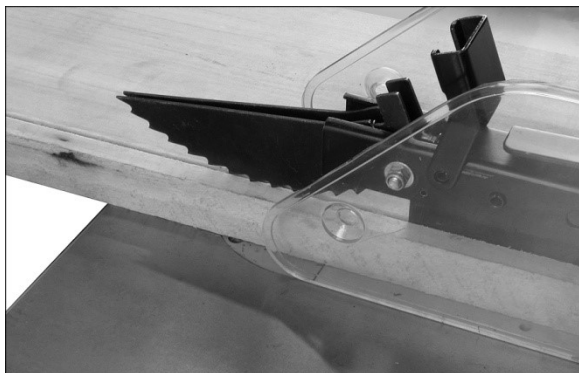

Figure 32

- Where possible, keep your face and body out of line with potential kickbacks including when starting or stopping the machine.
- Dull, badly set, improper, or improperly filed cutting tools, and cutting tools with gum or resin adhering to them can cause accidents. Never use a cracked saw blade. The use of a sharp, well maintained, and correct cutting tool for the operation will help avoid injuries.
- Support the work properly and hold it firmly against gauge or fence. Use a push stick or push block when ripping short,

narrow (6" width or less), or thin work. Use a push block or miter gauge hold-down when dadoing or molding.

- Never use the fence as a length stop when crosscutting. Do not hold or touch the free end or cutoff section of a workpiece. On through-sawing operations, the cutoff section must NOT be confined.
- Always keep your hands out of line of the saw blade and never reach back of the cutting blade with either hand to hold the workpiece.
- Bevel ripping cuts should always be made with the fence on the right side of saw blade so that the blade tilts away from the fence and minimizes the possibility of the work binding and the resulting kickback.

### 11.3 Rip sawing

Ripping is where the workpiece is fed with the grain into the saw blade using the fence or other positioning device as a guide to ensure desired width of cut (Figure 33).

**⚠WARNING** Before starting a ripping cut, verify that fence is clamped securely and aligned properly.

- Never rip freehand or use miter gauge in combination with the fence.
- Never rip workpieces shorter than the saw blade diameter.
- Never reach behind the blade with either hand to hold down or remove the cutoff piece with the saw blade rotating.



Figure 33

Always use blade guard, splitter/riving knife and anti-kickback pawls. Make sure splitter/riving knife is properly aligned. When wood is cut along the grain, the kerf tends to close and bind on the blade and kickbacks can occur.

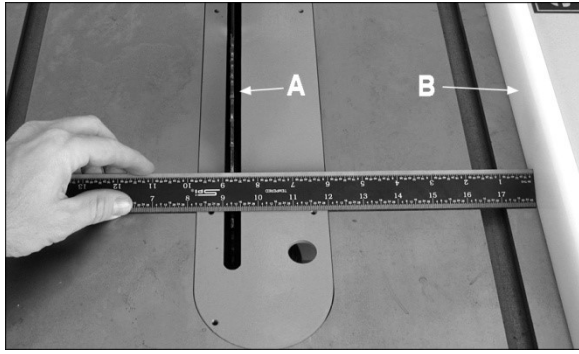

Figure 34

The rip fence (A, Fig. 34) should be set for the width of the cut by using the scale on the front rail, or by measuring the distance between blade (A) and fence (B). Stand out of line with saw blade and workpiece to avoid sawdust and splinters coming off the blade or a potential kickback.

If the work piece does not have a straight edge, nail an auxiliary straight edged board on it to provide one against the fence. To cut properly, the board must make good contact with the table. If it is slightly warped, turn the hollow side down. *Do not attempt to cut boards with significant warp.*

In ripping, use one hand to hold the board down against the fence or fixture, and the other to push it into the blade between blade and fence. If workpiece is narrower than 6" or shorter than 12", use a push stick or push block to push it through between fence and blade (Figure 35). Never push in a location such that the pushing hand is in line with the blade. Move the hand serving as a hold-down a safe distance from blade as cut nears completion.

For very narrow ripping where a push stick cannot be used, use a push block or auxiliary fence. Always push the workpiece completely past the blade at the end of a cut to minimize the possibility of a kickback.

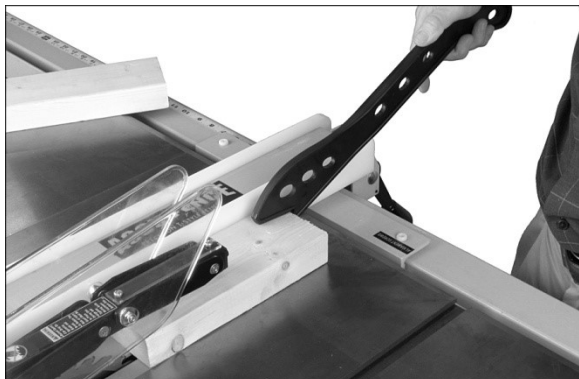

Figure 35

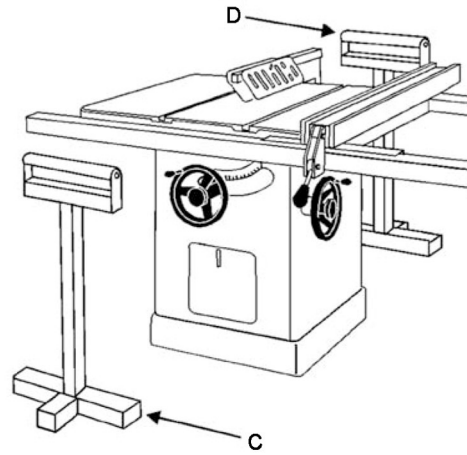

Figure 36

When ripping long boards, use a support at front of table (C, Figure 36), such as a roller stand, and a support or "tailman" at the rear (D).

Never use the rip fence beyond the point where the carriage is flush with the end of the rails.

Have the blade extend about 1/8" above the top of the workpiece. Exposing the blade above this point can be hazardous.

#### 11.4 Resawing

Resawing is a ripping operation in which thick boards are cut into thinner ones. Note: A band saw is the ideal tool for resawing.

**WARNING** If the table saw is used for resawing, take precautions such as using an auxiliary fence, resaw barrier or similar devices to stabilize the workpiece and provide operator safety.

Narrow boards up to 3" can be resawn in one pass. Wider boards up to 6" must be resawn in two passes.

In resawing wider boards, adjust the blade height so as to overlap the two cuts by 1/2" as shown in Figure 37. Too deep a first cut can result in binding and possible kickbacks on the second cut. Always use the same side of the board against the fence for both cuts.

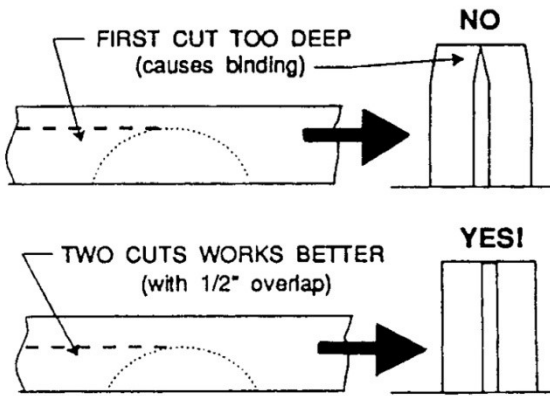

Figure 37

## 11.5 Crosscutting

Crosscutting is where the workpiece is fed cross grain into the saw blade using the miter gauge to support and position the workpiece (Figure 38).



Figure 38

Crosscutting should **never** be done freehand nor should the fence be used as an end stop unless an auxiliary block (E, Figure 39) is clamped to the front of the blade area such that the cutoff piece comes free of the block before cutting begins.

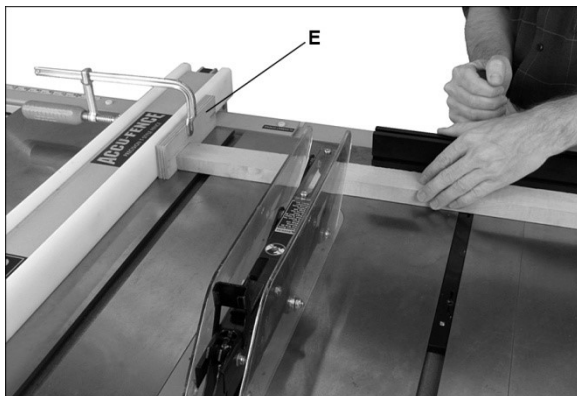

Figure 39

Length stops should not be used on the free end of the workpiece in the cutoff area.

Do **not** crosscut workpieces shorter than 6". Before starting a cut, be sure the miter gauge is securely

clamped at the desired angle. Hold the workpiece firmly against the table and back against the miter gauge. **Always** use the saw guard and riving knife and make sure the riving knife is properly aligned.

For 90 degree crosscutting, most operators prefer to use the left-hand miter gauge slot. When using it in this position, hold the workpiece against the gauge with the left hand and use the right hand to advance the workpiece. When using the right hand slot for miter and compound crosscutting so that the blade tilts away from the gauge, the hand positions are reversed.

When using the miter gauge, the workpiece must be held firmly and advanced smoothly at a slow rate. If the workpiece is not held firmly, it can vibrate causing it to bind on the blade and dull the saw teeth.

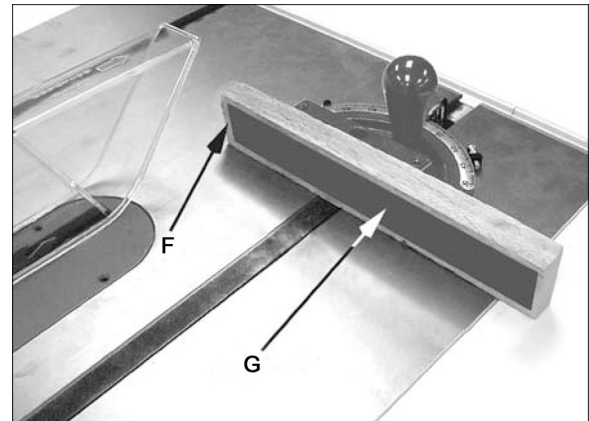

Figure 40

To augment the effectiveness of the miter gauge in crosscutting, some users mount an auxiliary wooden extension face (F, Figure 40) with a glued-on strip of sandpaper (G) to the miter gauge.

Provide auxiliary support for any workpiece extending beyond the table top with a tendency to sag and lift up off the table.

Have the blade extend about 1/8" above the top of the workpiece. Exposing the blade above this point can be hazardous.

## 11.6 Bevel and miter operations

**Bevel cut** – A bevel cut is a special type of operation where the saw blade is tilted at an angle less than 90 degrees to the table top (Figure 41). Operations are performed in the same manner as ripping or crosscutting, except the fence or miter gauge should be used on the right-hand side of the blade to provide added safety in avoiding a binding action between blade and table top. When beveling with the miter gauge, the workpiece must be held firmly to prevent creeping.



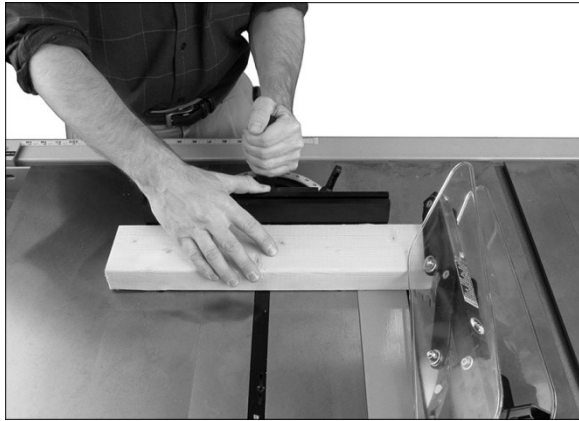

Figure 41

**Mitering** – Crosscuts made at an angle to the edge of the workpiece are called miters (Figure 42). Set the miter gauge at the required angle, and make the cut the same as a normal crosscut except the workpiece must be held extra firmly to prevent creeping.



Figure 42

**Note:** When making compound miters (with blade tilted) use the miter gauge in the **right** hand slot to provide more hand clearance and safety.

Have the blade extend only 1/8" above the top of the workpiece. Exposing the blade above this point can be hazardous.

## 11.7 Dado cutting

Dadoing is cutting a wide groove into a workpiece or cutting a rabbet along the edge of a workpiece. A dado insert (optional accessory, not provided) shown in Figure 43, is necessary for this type of operation.

**CAUTION** Do not use the standard table insert for dadoing operations.



Figure 43

The process of cutting 1/8" to 13/16" grooves in workpieces is accomplished by the use of a stacked dado blade set or an adjustable type blade mounted on the saw arbor. By using various combinations of stacked dado blades, or properly setting the dial on an adjustable blade, an accurate width dado can be made. This is very useful for shelving, making joints, tenoning, etc.

The guard, riving knife, and anti-kickback pawls supplied with the saw should be used for all cutting operations where they can be used. When performing operations where the guard cannot be used, as in some dadoing operations, alternative safety precautions should be taken. These include push sticks, feather boards, filler pieces, fixtures, jigs and any other appropriate device that can be utilized to keep operators' hands away from the blade. Upon completion of the operation requiring removal of the guard, the entire guard assembly must be placed back on the machine in its proper working order.

**CAUTION** Never use a dado head in a tilted position. Never operate the saw without the blade guard, riving knife and anti-kickback pawls for operations where they can be used.

## 12.0 Safety devices

### Feather board

Feather boards can be purchased at most tool stores, or made by the operator to suit particular applications. The feather board (Figure 44) should be made of straight grain hardwood approximately 1" thick and 4" to 8" wide depending on the size of the machine. The length is developed in accordance with intended use.

Feather boards can be fastened to the table or rip fence by use of C-clamps. Alternatively, drilled and tapped holes in the table top allow the use of wing nuts and washers as a method of clamping. If this method of fastening is used, provide slots in the feather board for adjustment. (The illustration shows a method of attaching and use of the feather board as a vertical comb. The horizontal application is essentially the same except that the attachment is to the table top.)

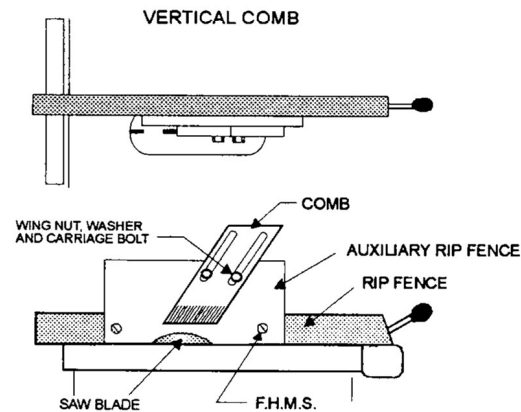
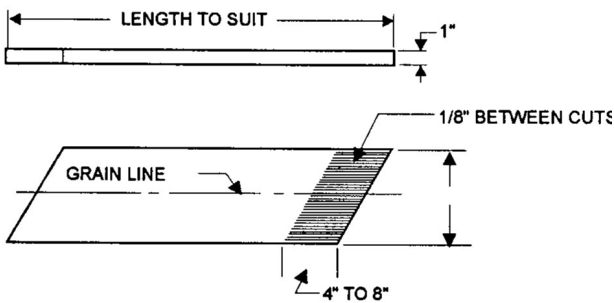

Figure 44

### Filler piece

A filler piece (Figure 45) is necessary for narrow ripping and permits the blade guard to remain on the machine. It also provides space for the safe use of a push stick.

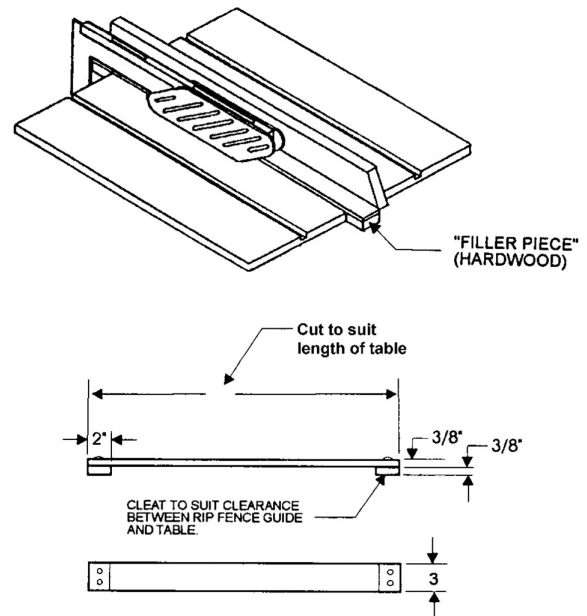

Figure 45 – Filler Piece

### Push stick and push block

The use of a push block or push stick provides an added level of safety for the operator. A push stick is included with your table saw, but you may wish to make others personalized for different cutting procedures. The templates in Figures 46 and 47 offer construction details.

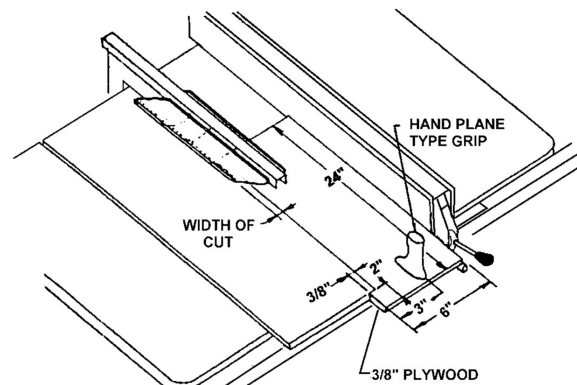

Figure 46 – Push Block Template

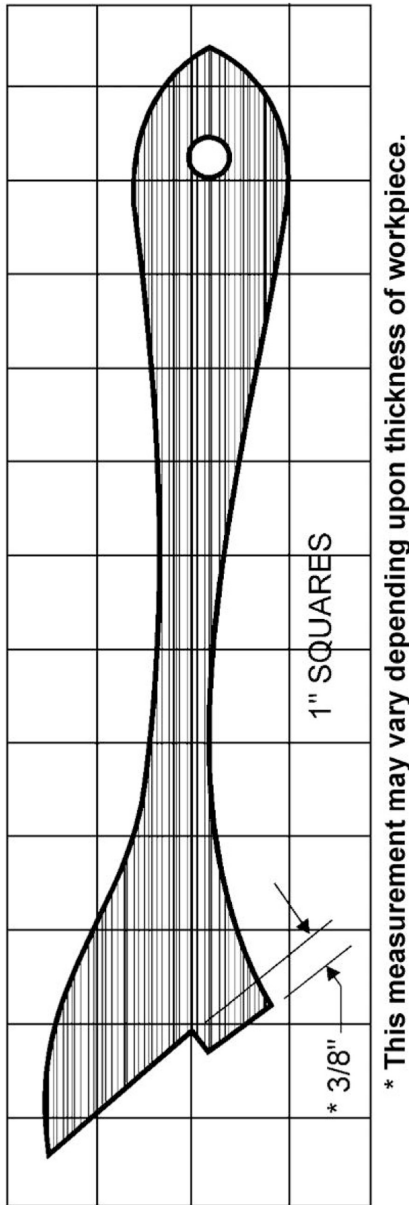

Figure 47 – Push stick template

## 13.0 Maintenance

**⚠ WARNING** Always disconnect power to the machine before performing maintenance. Failure to do this may result in serious personal injury.

### Cleaning

Clean the table saw according to the schedule below to ensure maximum performance. The schedule assumes the saw is being used every day.

#### Daily:

- Wipe down table surface and T-slots, and apply a rust preventive to them.
- Clean pitch and resin from saw blade.

#### Weekly:

- Clean motor housing with compressed air.
- Wipe down fence rails with a dry silicon lubricant.

### Lubrication

Refer to Figure 48.

Lower the arbor all the way, and lubricate the following elements with a lithium grease every 12 months, or more frequently if needed. Clean the elements first with a solvent/degreaser and a soft rag.

- Blade angling trunnions (A, Figure 48).
- Wipe a light coat of grease on the elevating rods (B).
- Threads of blade elevating screw (C)
- Threads of blade tilting screw (D).

Raise and lower arbor, and tilt it back and forth, to distribute the grease.

Check all adjustments after lubricating.

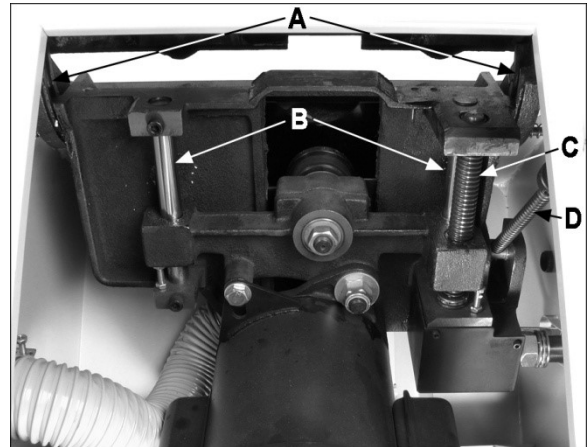

Figure 48

### Miscellaneous

Always be aware of the condition of your machine. Routinely check the condition of the following items and repair or replace as necessary:

- Mounting bolts (tighten)
- Power switch
- Saw blade (cracks, worn or dull teeth, etc.)
- Blade guard and riving knife
- Drive belt (cracks, frays, worn areas, etc.)

## 14.0 Optional accessories

These accessory items, purchased separately, can enhance the functionality of your table saw. Contact your dealer to order, or call Powermatic at the phone number on the cover.



p/n 1791088 – Dado insert for 64B table saw



p/n 708118 – Universal mobile base

*Figure 49*

# 15.0 Troubleshooting the 64B Table Saw

Table 2

Trouble	Probable Cause	Remedy
Table saw will not start.	No incoming power.	Check all plug connections.
	Fuse blown, or circuit breaker tripped.	Replace fuse, or reset circuit breaker.
	Cord damaged.	Replace cord.
Excessive vibration.	Tilting or raising lock knobs not tightened.	Tighten lock knobs on handwheels.
	Machine not resting evenly on floor.	Adjust foot pad(s). If saw is secured to floor, use shims as needed.
	Blade out of balance.	Replace blade.
	Pulley loose.	Check motor pulley and spindle pulley. Tighten set screws if needed.
	Belt is worn, cracked or frayed.	Replace belt.
	Motor not functioning properly.	Have motor checked by a qualified inspector. Repair or replace.
Cuts out-of-square when crosscutting.	Miter gauge out of adjustment.	Re-set stops and pointer on gauge. (Section 10.3).
	Miter slot misaligned.	Realign table to blade (Section 10.8).
Motor stalls or workpiece binds or burns.	Excessive feed.	Reduce feed.
	Dull or incorrect blade.	Replace blade; use proper type of blade for cut needed.
	Miter slot misaligned.	Realign table to blade (Section 10.8).
	Fence misaligned.	Realign fence (see Accu-Fence® manual).
	Motor malfunction.	Have motor checked by a qualified inspector. Repair or replace.
	Cuts not true at 90 or 45 degrees.	Stop screws not set properly.
Tilting or Raising handwheel difficult to turn.	Lock knob not released.	Loosen lock knob.
	Worm and worm gear segment caked with sawdust and pitch.	Clean and regrease worm and worm gear segment.
	Worm and worm gear segment out of alignment.	Realign worm with segment.
Motor overheats	Motor overloaded.	Identify and correct overload condition, e.g. excessive feed rate of stock.
	Improper cooling of motor; lack of air circulation.	Clean sawdust from fan and duct areas of motor.
Motor starts slowly or fails to come up to full speed.	Low voltage.	Request voltage check from power company and correct low voltage condition.
	Centrifugal switch not operating.	Replace centrifugal switch (qualified personnel only).
	Motor malfunction.	Have motor checked by a qualified inspector. Repair or replace.
Motor fails to develop full power.	Power line overloaded.	Correct overload condition.
	Undersized wires in supply system.	Increase supply wire size.
	Low voltage.	Request voltage check from power company and correct low voltage condition.
	Motor malfunction.	Have motor checked by a qualified inspector. Repair or replace.

# 16.0 Replacement Parts

Replacement parts are listed on the following pages. To order parts or reach our service department, call 1-800-274-6848 Monday through Friday, 8:00 a.m. to 5:00 p.m. CST. Having the Model Number and Serial Number of your machine available when you call will allow us to serve you quickly and accurately.

Non-proprietary parts, such as fasteners, can be found at local hardware stores, or may be ordered from Powermatic.

Some parts are shown for reference only, and may not be available individually.

## 16.1.1 Table and Cabinet Assembly – Exploded View

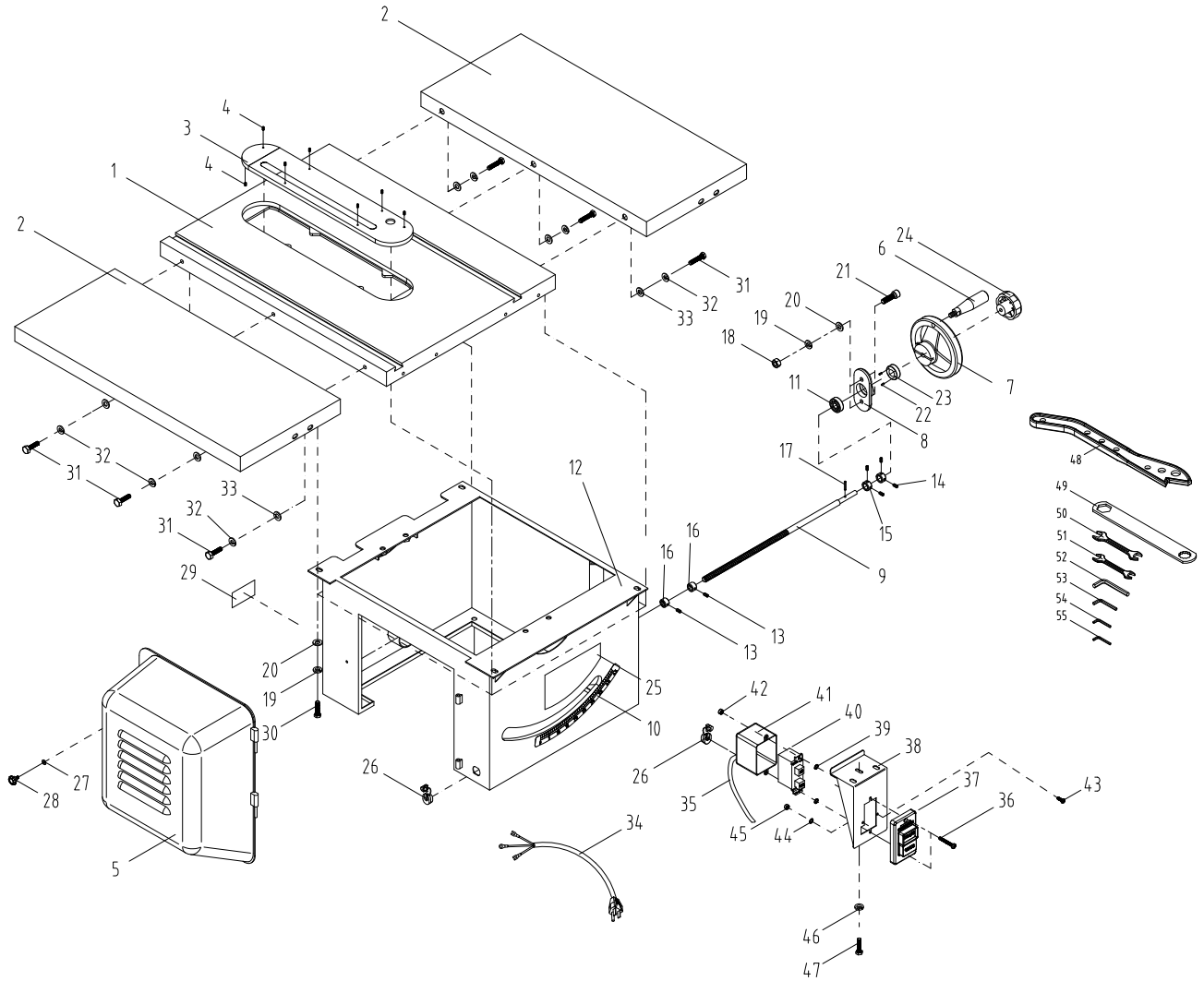

## 16.1.2 Table and Cabinet Assembly – Parts List

Index No	Part No	Description	Size	Qty
1	64B-101	Table		1
2	64B-102	Table Extension		2
	64B-TIA	Table Insert Assembly (#3 thru #4)		1
3	64B-103	Table Insert		1
4	TS-1522011	Socket Set Screw	M5x5	6
5	64B-105	Cover		1
6	3520B-126	Handle		1
7	64B-107	Handwheel		1
8	64B-108	Cover Plate		1
9	64B-109	Lead Screw		1
10	64B-110	Angle Scale		1
11	BB-6201ZZ	Ball Bearing	6201ZZ	1
12	64B-112	Cabinet		1
13	TS-1523021	Socket Set Screw	M6x8	4
14	TS-1523011	Socket Set Screw	M6x5	4
15	64B-115	Bushing		2
16	64B-116	Bushing		2
17	64B-117	Spring Pin	Ø4x25 mm	1
18	TS-1540061	Hex Nut	M8	2
19	TS-2361081	Lock Washer	M8	6
20	TS-1550061	Flat Washer	M8	6
21	TS-1504071	Socket Head Cap Screw	M8x35	2
22	64B-122	Spring Pin	Ø3x12 mm	2
23	64B-123	Lock Bushing		1
24	64B-124	Lock Knob		1
25	LM000636	Warning Label		1
26	6290630	Strain Relief	7W-2	3
27	TS-1550031	Flat Washer	M5	1
28	64B-128	Lock Knob		1
29	64B-129	I.D label		1
30	TS-1490031	Hex Cap Screw	M8x20	4
31	TS-1491041	Hex Cap Screw	M10x30	6
32	TS-2361101	Lock Washer	M10	6
33	TS-1550071	Flat Washer	M10	6
34	64B-134	Power Cord		1
35	64B-135	Motor Cord		1
36	TS-081C082	Phillips Pan Head Machine Screw	#10-24x1-1/2"	2
37	6296133	Switch Push Button		1
38	6291367	Switch Bracket		1
39	TS-0733031	Star Washer	#10	2
40	6296128	Switch		1
41	6291366	Switch Box		1
42	TS-0560071	Hex Nut	#10-24	2
43	TS-1533032	Phillips Pan Head Machine Screw	M5x10	2
44	TS-0733041	Star Washer	1/4"	2
45	TS-1540031	Hex Nut	M5	2
46	TS-0720071	Lock Washer	1/4"	1
47	TS-0050031	Hex Cap Screw	1/4"-20x3/4"	1
48	JPS10TSR-103	Push Block		1
49	6290642	Arbor Wrench		1
50	JBOS5-105	Open End Wrench	#14-#17	1
51	JBOS5-106	Open End Wrench	#10-#12	1
52	TS-152707	Hex Key	6mm	1
53	TS-152705	Hex Key	4mm	1
54	TS-152704	Hex Key	3mm	1
55	JPS10TSR-105	Hex Key	2.5mm	1
	64B-HP	Hardware Package (includes #31-33)		1

### 16.2.1 Motor and Trunnion Assembly – Exploded View

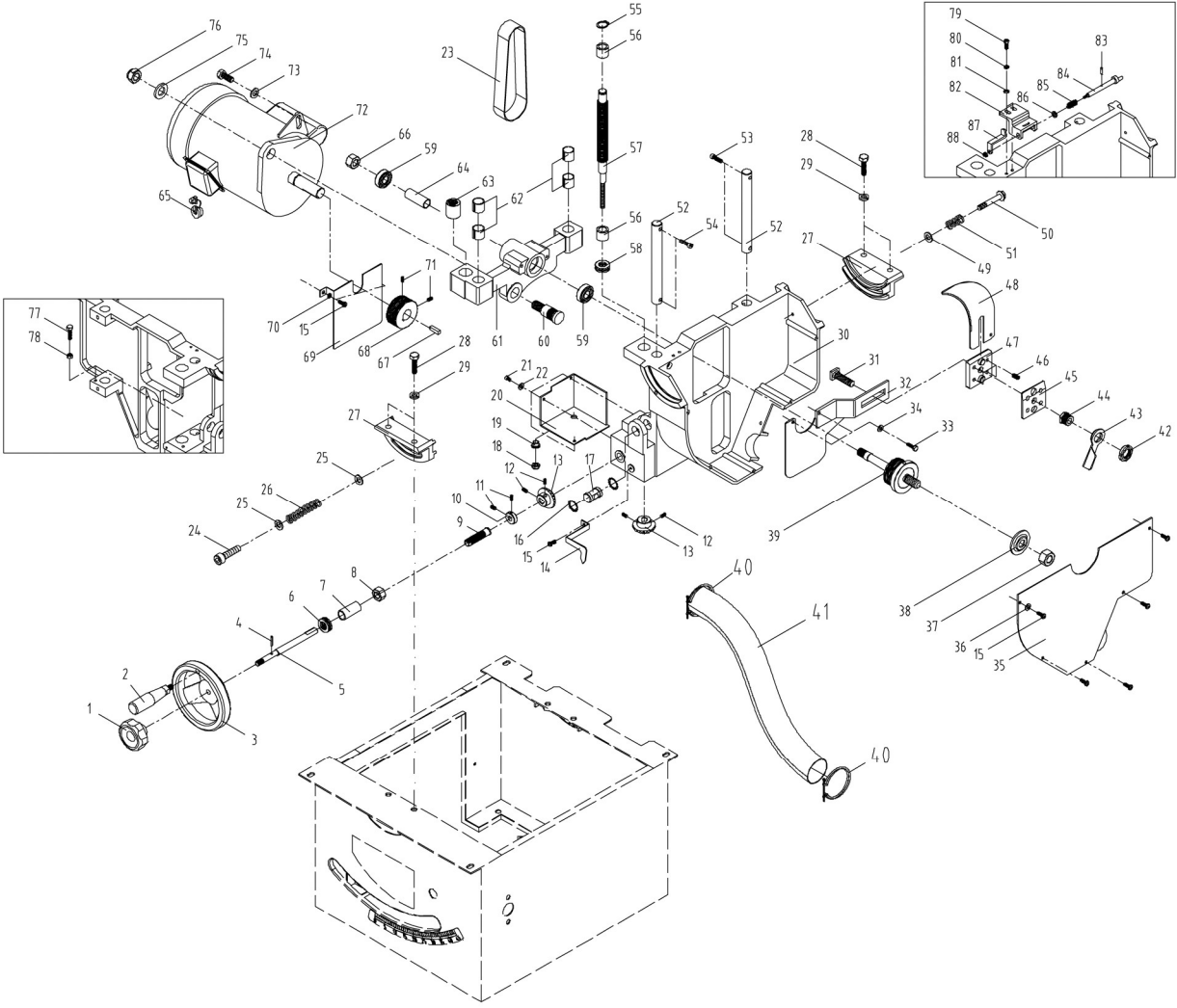



## 16.2.2 Motor and Trunnion Assembly – Parts List

Index No	Part No	Description	Size	Qty
1	64B-124	Lock Knob		1
2	3520B-126	Handle		1
3	64B-107	Handwheel		1
4	64B-117	Spring Pin	Ø4x25 mm	1
5	64B-205	Lead Screw		1
6	64B-206	Thrust Bearing	51104	1
7	64B-207	Bushing		1
8	TS-154012	Hex Nut	M20-2.5P	1
9	64B-209	Bushing		1
10	64B-210	Spacer		1
11	TS-1522031	Socket Set Screw	M5x10	2
12	TS-0267041	Socket Set Screw	1/4"-20x3/8"	4
13	64B-213	Gear		2
14	64B-214	Pointer		1
15	TS-1533052	Phillips Pan Head Machine Screw	M5x15	8
16	64B-216	Lock Washer		2
17	64B-217	Guide Shaft		1
18	TS-1541031	Nylon Lock Hex Nut	M8	1
19	64B-219	Bearing		1
20	64B-220	Gear Cover		1
21	TS-1532042	Phillips Pan Head Machine Screw	M4x12	3
22	TS-1550021	Flat Washer	M4	3
23	64B-223	Poly-V Belt	188J	1
24	64B-224	Socket Head Cap Screw	M8x65	1
25	TS-1550061	Flat Washer	M8	2
26	64B-226	Spring		1
27	64B-227	Trunnion		2
28	TS-1491031	Hex Cap Screw	M10x25	4
29	TS-2361101	Lock Washer	M10	4
30	64B-230	Center Trunnion		1
31	64B-231	Screw		1
32	64B-232	Support Base		1
33	TS-1482031	Hex Cap Screw	M6x16	2
34	TS-1550041	Flat Washer	M6	2
35	64B-235	Cover		1
36	TS-1550031	Flat Washer	M5	5
37	6290693	Arbor Nut		1
38	6290598	Flange		1
39	64B-239	Arbor		1
40	64B-240	Clamp	3"	2
41	64B-241	Hose		1
42	64B-242	Nut		1
43	64B-243	Lock Handle		1
44	64B-244	Bolt		1
45	64B-245	Holding Plate		1
46	TS-1524011	Socket Set Screw	M8x8	4
47	64B-247	Support Base		1
48	64B-248	Low Profile Riving Knife		1
49	TS-1550041	Flat Washer	M6	1
50	64B-250	Bolt		1
51	64B-251	Spring		1
52	64B-252	Moving Rod		2
53	TS-1504041	Socket Head Cap Screw	M8x20	2
54	TS-1504071	Socket Head Cap Screw	M8x35	2
55	64B-255	S-Ring	S15	1
56	64B-256	Bushing		2
57	64B-257	Lead Screw		1
58	64B-258	Thrust Bearing		1
59	64B-259	Ball Bearing	6202-5/8" bore	2

Index No	Part No	Description	Size	Qty
60	64B-260	Shaft		1
61	64B-261	Bracket		1
62	64B-262	Bearing		4
63	64B-263	Thread Housing		1
64	64B-264	Bushing		1
65	6290630	Strain Relief	7W-2	1
66	64B-266	Hex Nut (L.H Thread)	M14-2.0P	1
67	64B-267	Key	5x5x25 mm	1
68	64B-268	Motor Pulley		1
69	64B-269	Plate		1
70	TS-2361051	Lock Washer	M5	2
71	TS-1523031	Socket Set Screw	M6x10	2
72	64B-272	Motor		1
	64B-272MF	Motor Fan (not shown)		1
	64B-272MFC	Motor Fan Cover (not shown)		1
	64B-272CS	Centrifugal Switch (not shown)		1
	64B-272SCC	Starting Capacitor Cover (not shown)		1
	64B-272RCC	Running Capacitor Cover (not shown)		1
	64B-272SC	Starting Capacitor (not shown)	400MFD, 125VAC	1
	64B-272RC	Running Capacitor (not shown)	30µf, 250VAC	1
	64B-272JB	Junction Box (not shown)		1
	64B-272JBC	Junction Box Cover (not shown)		1
	64B-272OL	Overload (not shown)		1
	64B-272DC	Dust Cover (not shown)		1
73	TS-1550071	Flat Washer	M10	1
74	TS-1491031	Hex Cap Screw	M10x25	1
75	TS-0680081	Flat Washer	5/8"	1
76	64B-276	Nylon Lock Hex Nut	5/8"-11	1
77	TS-1482061	Hex Cap Screw	M6x30	2
78	TS-2311061	Hex Nut	M6	2
	64B-ALA	Arbor Lock Assembly (#82 thru 88)		1
79	TS-1502041	Socket Head Cap Screw	M5x16	2
80	TS-2361051	Lock Washer	M5	2
81	TS-1550031	Flat Washer	M5	2
82	64B-282	Bracket		1
83	64B-283	Spring Pin	Ø3x25 mm	1
84	64B-284	Lock Shaft		1
85	64B-285	Spring		1
86	TS-1550061	Flat Washer	M8	1
87	64B-287	Handle		1
88	TS-1541001	Hex Nylon Lock Nut	M4	1

### 16.3.1 Stand Assembly – Exploded View

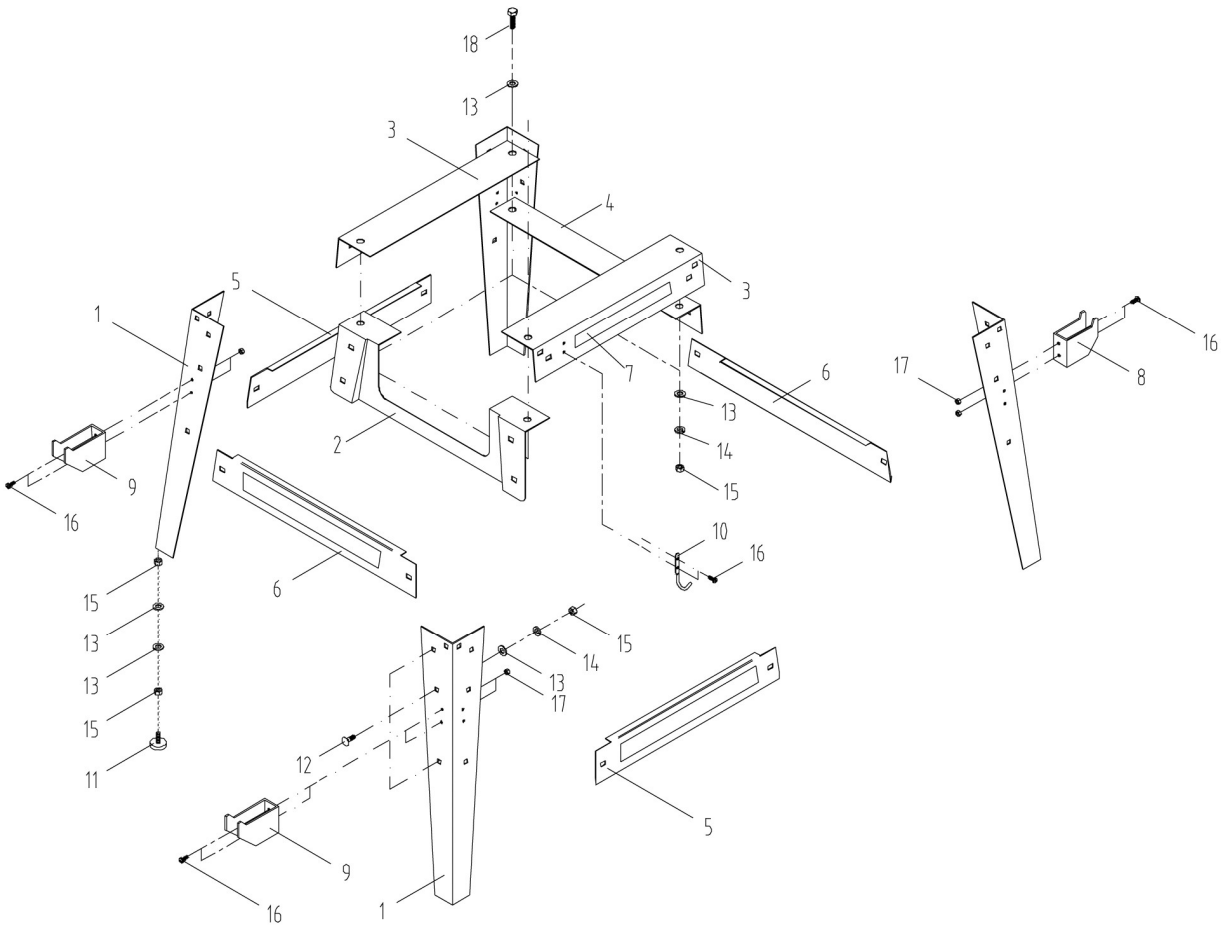

### 16.3.2 Stand Assembly – Parts List

Index No	Part No	Description	Size	Qty
1	64B-301	Leg		4
2	64B-302	Upper Side Brace		1
3	64B-303	Upper Short Brace		2
4	64B-304	Upper Long Brace		1
5	64B-305	Lower Short Brace (includes stripe)		2
6	64B-306	Lower Long Brace (includes stripe)		2
7	64B-307	Powermatic Nameplate Label	1-1/2"W x 10"L	1
8	64B-308	Miter Gauge Hook		1
9	64B-309	Fence Body Hook		2
10	64B-310	Hook		1
11	64B-311	Rubber Foot Pad		4
12	64B-312	Carriage Bolt	M8x16	24
13	TS-1550061	Flat Washer	M8	40
14	TS-2361081	Lock Washer	M8	28
15	TS-1540061	Hex Nut	M8	36
16	TS-1533052	Phillips Pan Head Machine Screw	M5x15	8
17	TS-1540031	Hex Nut	M5	8
18	TS-1490041	Hex Cap Screw	M8x25	4
	64B-SHP	Stand Hardware Package (#12 thru 18)		1
	3520B-158	Black Stripe		per ft.

### 16.4.1 Blade Guard and Miter Gauge Assemblies – Exploded View

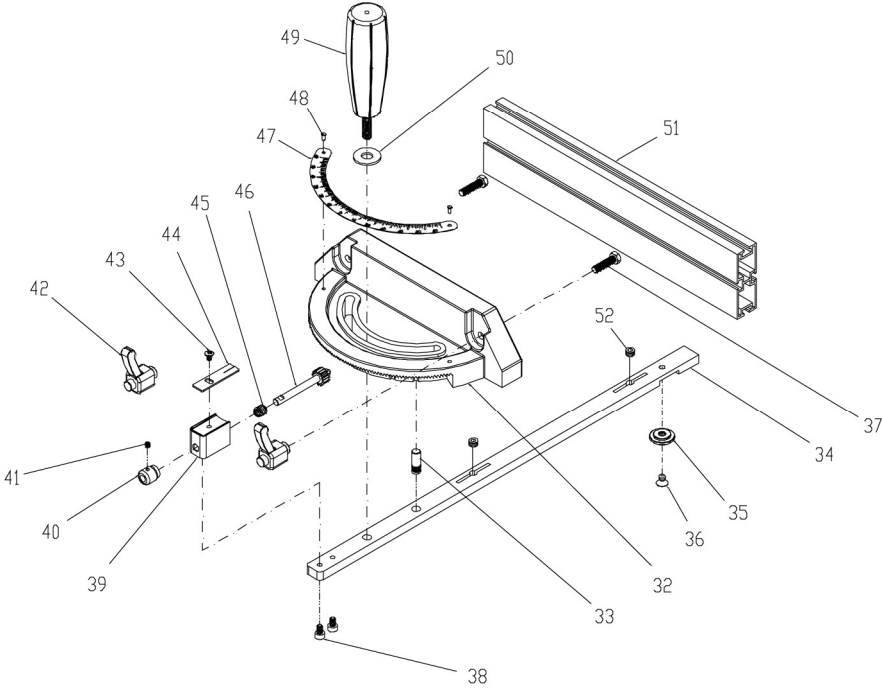
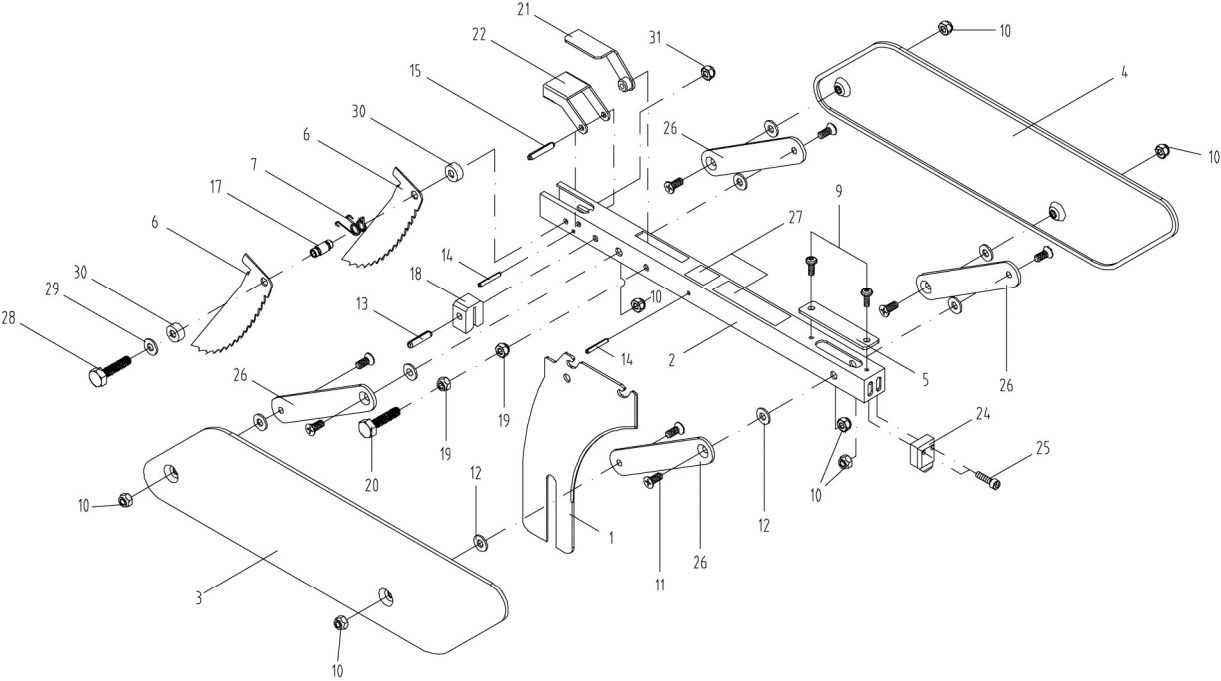

## 16.4.2 Blade Guard and Miter Gauge Assemblies – Parts List

Index No	Part No	Description	Size	Qty
	64B-BGA	Blade Guard Assembly (#1 thru 31)		1
1	64B-401	Riving Knife		1
	64B-UGA	Upper Guard Assembly (#2 thru 31)		1
2	64B-402	Support Arm		1
3	64B-403	Left side Blade Guard		1
4	64B-404	Right Side Blade Guard		1
5	64B-405	Plate		1
6	64B-406	Anti-Kickback Pawl		2
7	64B-407	Spring		1
9	TS-1533032	Phillips Pan Head Machine Screw	M5x10	2
10	TS-0640071	Nylon Lock Hex Nut	1/4"-20	8
11	TS-0813051	Flat Head Screw	1/4"-20x5/8"	8
12	TS-0680021	Flat Washer	1/4"	8
13	64B-413	Spring Pin	Ø6x30 mm	1
14	64B-414	Spring Pin	Ø3.5x28 mm	2
15	64B-415	Spring Pin	Ø5x35 mm	1
17	64B-417	Shaft		1
18	64B-418	Holding Bracket		1
19	TS-1541021	Nylon Lock Hex Nut	M6	2
20	TS-1482071	Hex Cap Screw	M6x35	1
21	64B-421	Lock Handle		1
22	64B-422	Holding Bracket		1
24	64B-424	Front Shield		1
25	TS-1502021	Socket Head Cap Screw	M5x10	2
26	64B-426	Pivot Arm		4
27	64B-427	Warning Label		1
28	TS-1481081	Hex Cap Screw	M5x35	1
29	TS-1550031	Flat Washer	M5	1
30	64B-430	Bushing		2
31	TS-1541011	Nylon Lock Hex Nut	M5	1
	1791789	Miter Gauge Assembly (#32 thru 52)		1
32	PM2000-323	Miter Gauge Body		1
33	PM2000-324	Pin		1
34	PM2000-325	Miter Bar		1
35	PM2000-326	Guide Washer		1
36	PM2000-327	Flat Head Machine Screw	M6x9	1
37	TS-0050051	Hex Cap Screw	1/4"-20x1"	2
38	PM2000-329	Socket Head Cap Screw	M5x8	2
39	PM2000-330	Support Base		1
40	PM2000-331	Knob		1
41	TS-1521011	Socket Set Screw	M4x4	1
42	PM2000-333	Locking Handle		2
43	TS-0810012	Phillips Pan Head Machine Screw	#10-24x1/4"	1
44	PM2000-335	Pointer		1
45	PM2000-336	Spring		1
46	PM2000-337	Gear Shaft		1
47	PM2000-338	Scale		1
48	PM2000-339	Rivet		2
49	PM2000-340	Handle		1
50	TS-0680031	Flat Washer	5/16"	1
51	PM2000-342	Fence		1
52	PM2000-343	Socket Set Screw	M8x6	2

# 17.0 Electrical Connections

## 17.1 Connections for 115 volt (64B Table Saw)

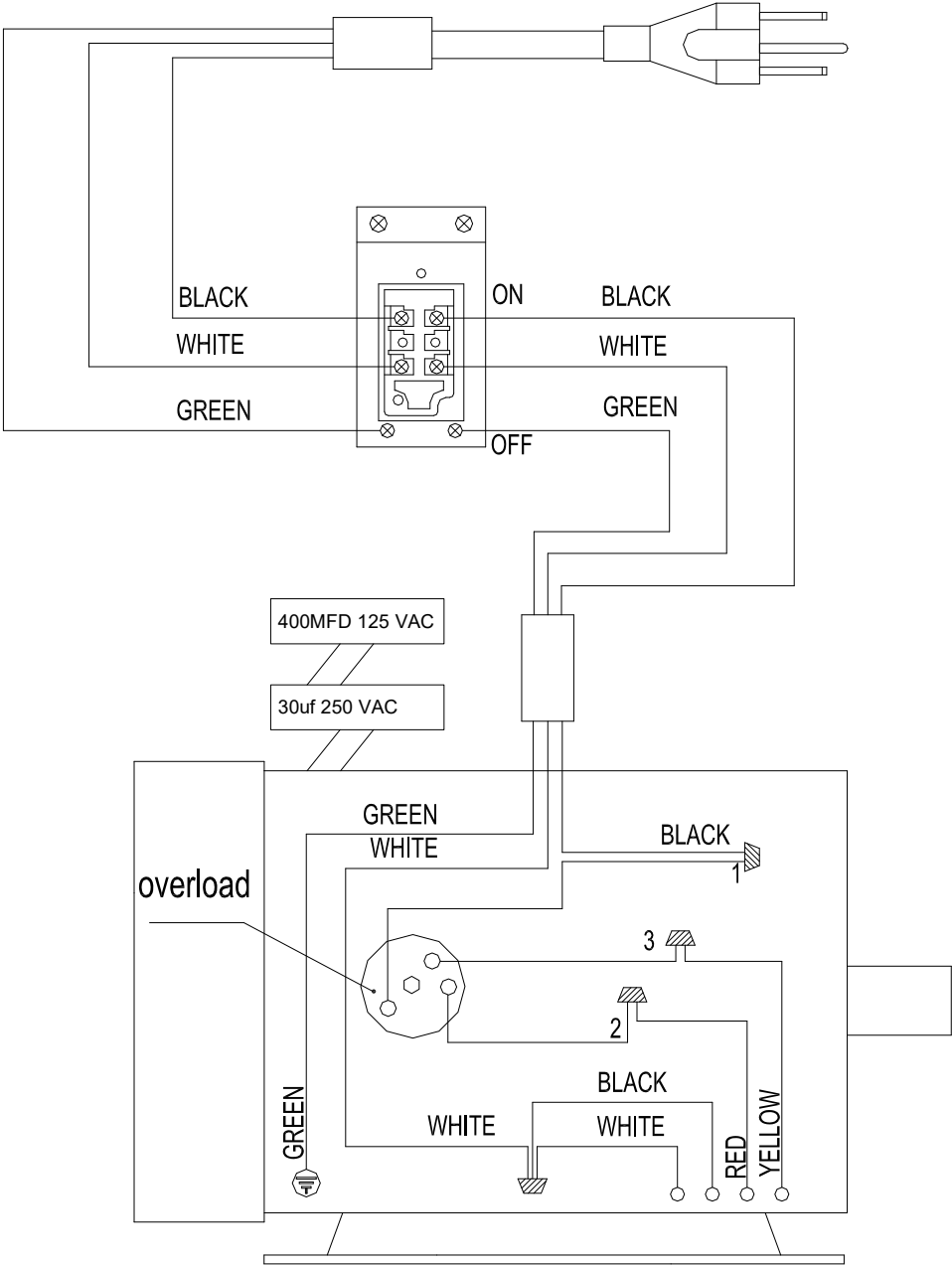

**115V**

17.2 Connections for 230 volt (64B Table Saw)

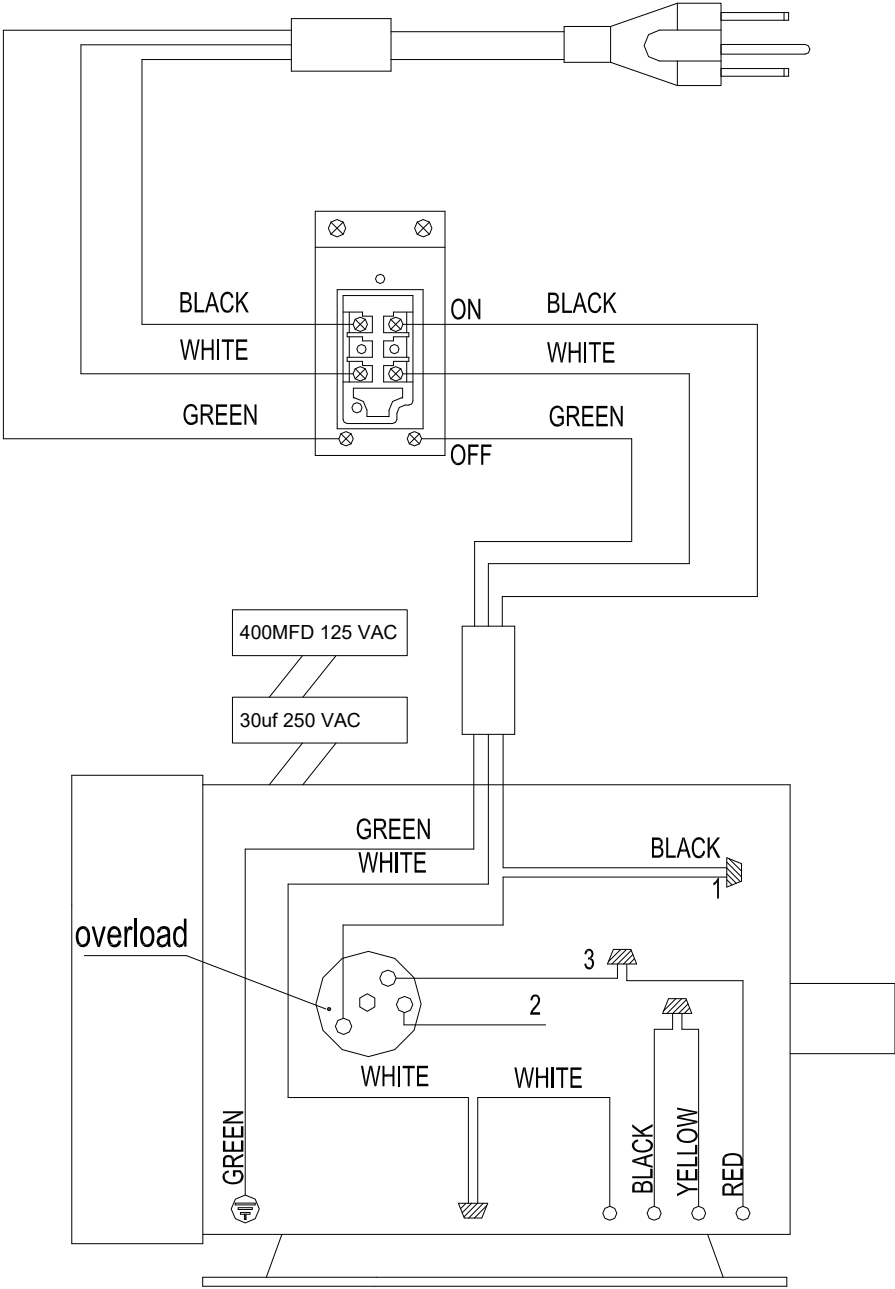

**230V**



427 New Sanford Road  
LaVergne, Tennessee 37086  
Phone: 800-274-6848  
[www.powermatic.com](http://www.powermatic.com)