

JOHN DEERE
WORLDWIDE COMMERCIAL & CONSUMER
EQUIPMENT DIVISION

Lawn Care Tools
Tow-Behind

OMM138188 G0

OPERATOR'S MANUAL



North American Version
Litho in U.S.A.

FWU

OMM138188

INTRODUCTION

Thank You for Purchasing a John Deere Product

We appreciate having you as a customer and wish you many years of safe and satisfied use of your machine.

Using Your Operator's Manual

This manual is an important part of your machine and should remain with the machine when you sell it.

Reading your operator's manual will help you and others avoid personal injury or damage to the machine. Information given in this manual will provide the operator with the safest and most effective use of the machine. Knowing how to operate this machine safely and correctly will allow you to train others who may operate this machine.

This manual and safety signs on your machine may also be available in other languages (see your John Deere dealer to order).

Sections in your operator's manual are placed in a specific order to help you understand all the safety messages and learn the controls so you can operate this machine safely. You can also use this manual to answer any specific operating or servicing questions. A convenient index located at the end of this book will help you to find needed information quickly.

The machine shown in this manual may differ slightly from your machine, but will be similar enough to help you understand our instructions.

RIGHT-HAND and LEFT-HAND sides are determined by facing in the direction the machine will travel when going forward. When you see a broken line arrow (----->), the item referred to is hidden from view.

Before delivering this machine, your dealer performed a predelivery inspection to ensure best performance.

Special Messages

Your manual contains special messages to bring attention to potential safety concerns, machine damage as well as helpful operating and servicing information. Please read all the information carefully to avoid injury and machine damage.

IMPORTANT: Avoid damage! This text is used to tell the operator of actions or conditions that might result in damage to the machine.

NOTE: General information is given throughout the manual that may help the operator in the operation or service of the machine.



CAUTION: Avoid injury! This symbol and text highlight potential hazards or death to the operator or bystanders that may occur if the hazards or procedures are ignored.

PRODUCT INFORMATION

Record Product Information

Tow-Behind Lawn Care Tools

Thatcherator, Plug Aerator, Spiker Aerator, Aerator/ Spreader, and Lawn Roller

In the event you need to contact an Authorized Service Center for information on servicing your product, record the following information in the spaces provided below.

DATE OF PURCHASE:

DEALER NAME:

DEALER PHONE:

TABLE OF CONTENTS

Safety	1
Installing	4
Removing	5
Operating - Thatcherator	6
Operating - Plug Aerator.....	9
Operating - Spiker Aerator.....	11
Operating - Aerator-Spreader.....	13
Operating - Lawn Roller.....	17
Service	18
Storage	19
Assembly - Thatcherator	20
Assembly - Plug Aerator.....	24
Assembly - Spiker Aerator.....	27
Assembly - Aerator-Spreader.....	30
Assembly - Lawn Roller.....	35
Specifications	37
Index.....	39

All information, illustrations and specifications in this manual are based on the latest information at the time of publication. The right is reserved to make changes at any time without notice.

COPYRIGHT© 2000
Deere & Co.
John Deere Worldwide Commercial and
Consumer Equipment Division
Horicon, WI
All rights reserved
Previous Editions
COPYRIGHT©

OMM138188 G0 - English

SAFETY

Understanding The Machine Safety Labels

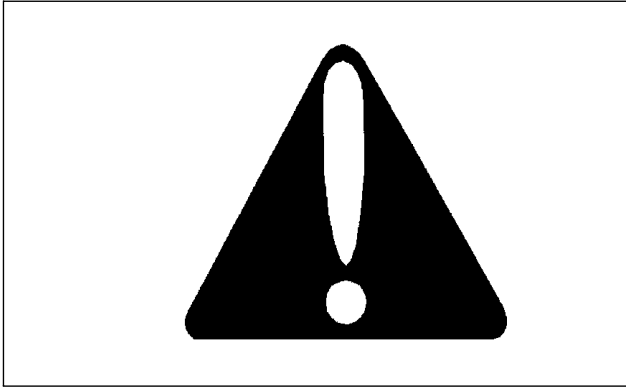

The machine safety labels shown in this section are placed in important areas on your machine to draw attention to potential safety hazards.

On your machine safety labels, the words DANGER, WARNING, and CAUTION are used with this safety-alert symbol, (▲). DANGER identifies the most serious hazards.

The operator's manual also explains any potential safety hazards whenever necessary in special safety messages that are identified with the word, CAUTION, and the safety-alert symbol, (▲).

WARNING



To avoid injury, read operator's manual. Never carry riders. Keep hands and feet away from all moving parts.

Operate Safely

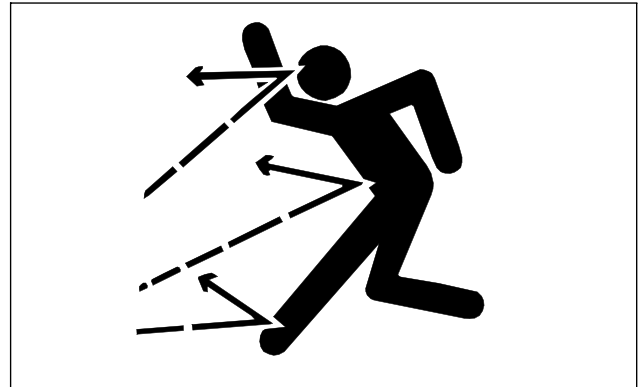

- Know your controls and how to stop quickly. Read your machine Operator's Manual.
- Keep hands and feet away from all moving parts.
- To avoid possible personal injury and/or equipment damage, never exceed the recommended operating speed range of 5 to 8 km/hr (3 to 5 mph).
- DO NOT attempt to disconnect attachment from tractor with weight or spreading material remaining in the attachment.
- Tines and plugging spoons have extremely sharp points. Wear gloves and handle with care.
- Store attachment with tines against wall or floor to avoid accidental contact.
- Watch out for traffic when crossing or near roadways.
- Only tow your attachment behind machines for which it was designed. See your John Deere dealer for product information.
- Check vehicle brake action before you operate. Adjust or service brakes as necessary.
- Inspect machine and attachment before you operate. Be sure hardware is tight. Repair or replace damaged, badly worn, or missing parts. Be sure guards and shields are in good condition and fastened in place. Make any necessary adjustments before you operate.
- Clear work area of objects that might be thrown or struck. Keep people and pets out of the work area. Stop machine if anyone enters the area.
- If you hit an object, stop and inspect machine and attachment. Make repairs before you operate. Keep machine and attachment properly maintained and in good working order.
- DO NOT leave machine unattended when it is running.
- Only operate during daylight or with good artificial light.
- DO NOT let anyone, especially children, stand or ride on machine or attachment.

SAFETY

- DO NOT let children or an untrained person operate machine.
- Do not wear radio or music headphones while operating the machine. Safe operation requires your full attention.

Wear Appropriate Clothing

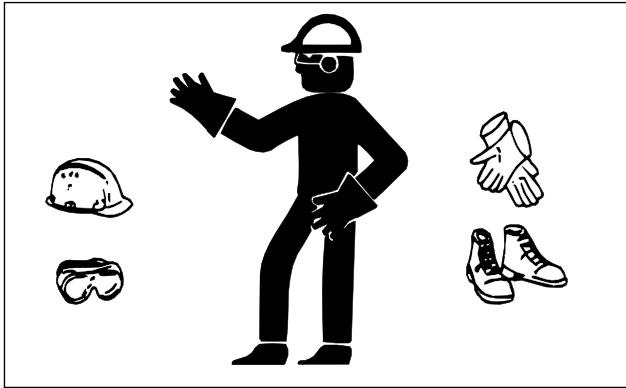

- Wear close fitting clothing and safety equipment appropriate for the job.
- Always wear safety goggles or safety glasses with side shields when operating the mower.
- Wear a suitable protective device such as earplugs. Loud noise can cause impairment or loss of hearing.
- Do not wear radio or music headphones. Safe service and operation requires your full attention.

Handling Waste Product and Chemicals

Waste products, such as, used oil, fuel, coolant, brake fluid, and batteries, can harm the environment and people:

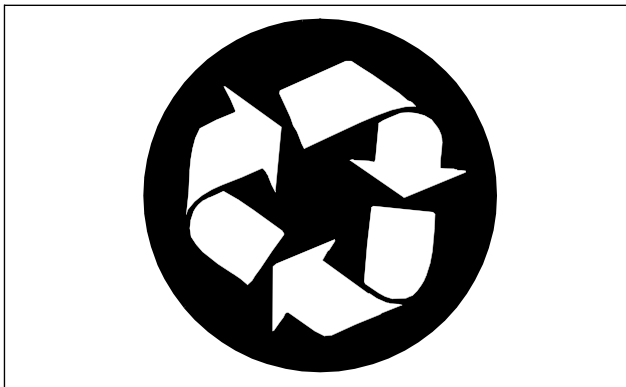

- DO NOT use beverage containers for waste fluids - someone may drink from them.
- See your local Recycling Center or John Deere dealer to learn how to recycle or get rid of waste products.
- A Material Safety Data Sheet (MSDS) provides specific

details on chemical products: physical and health hazards, safety procedures, and emergency response techniques. The seller of the chemical products used with your machine is responsible for providing the MSDS for that product.

Practice Safe Maintenance



- Understand service procedure before doing work. Keep area clean and dry.
- Plugging spoons and tines are sharp. Wear gloves and handle with care.
- Remove all weight and/or material from attachment before disconnecting unit from tractor.
- Never lubricate, service, or adjust machine while it is moving. Keep safety devices in place and in working condition. Keep hardware tight.
- Keep hands, feet, clothing, jewelry, and long hair away from any moving parts, to prevent them from getting caught.
- Lower attachments to the ground before servicing machine. Disengage all power and stop the engine. Lock park brake and remove the key. Let machine cool.
- Keep all parts in good condition and properly installed. Fix damage immediately. Replace worn or broken parts. Replace all worn or damaged safety and instruction decals.
- Do not modify machine or safety devices. Unauthorized modifications may impair its function and safety.
- Do not wear radio or music headphones while servicing the machine. Safe service requires your full attention.

Parking Safely

1. Stop machine on a level surface, not on a slope.
2. Disengage mower blades.
3. Lower attachments to the ground.
4. Lock the park brake.

SAFETY

5. Stop the engine.
6. Remove the key.
7. Wait for engine and all moving parts to stop before you leave the operator's seat.
8. Close fuel shut-off valve, if your machine is equipped.

Tire Safety

Explosive separation of a tire and rim parts can cause serious injury or death:



- Do not attempt to mount a tire without the proper equipment and experience to perform the job.
- Always maintain the correct tire pressure. Do not inflate the tires above the recommended pressure. Never weld or heat a wheel and tire assembly. The heat can cause an increase in air pressure resulting in a tire explosion. Welding can structurally weaken or deform the wheel.
- When inflating tires, use a clip-on chuck and extension hose long enough to allow you to stand to one side and NOT in front of or over the tire assembly.
- Check tires for low pressure, cuts, bubbles, damaged rims or missing lug bolts and nuts.

INSTALLING

Installing Tow-Behind Attachment

1. Park tractor safely. (See Parking Safely in the SAFETY section.)
2. Place the attachment behind the tractor.

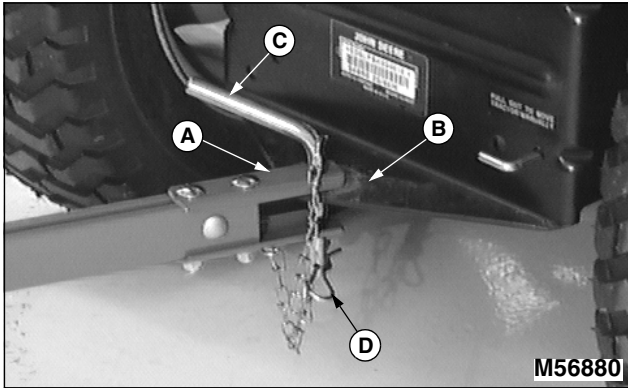

3. Place clevis (A) onto tractor hitch plate (B). Align the hitch pin holes.
4. Install hitch pin (C) through holes in clevis and hitch plate.
5. Secure spring locking pin (D) through hole in hitch pin.

REMOVING

Removing Tow-Behind Attachment

1. Park tractor safely. (See Parking Safely in the SAFETY section.)



CAUTION: Avoid injury! Do not attempt to disconnect attachment from tractor with weight or spreading material remaining in the unit. Attachment could become unstable causing injury.

2. Remove all weight and/or material from attachment.

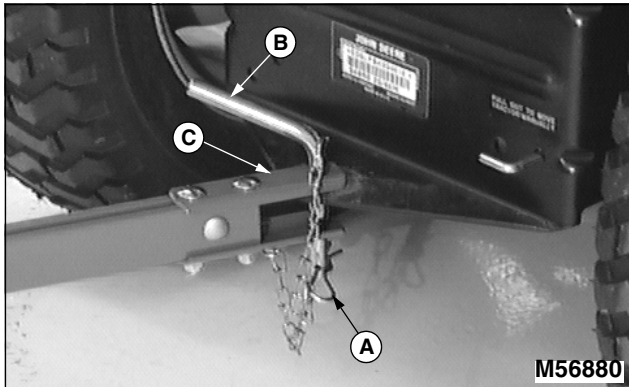

3. Remove spring locking pin (A).
4. Remove hitch pin (B).
5. Move attachment off tractor hitch plate.
6. Install hitch pin and spring locking pin to clevis (C) for storage.

OPERATING - THATCHERATOR

When to Use the Thatcherator

The best times to dethatch are spring and fall. Grass should be less than 76 mm (3 in.) high for proper tine action.

Spring dethatching gives the grass a chance to grow strong before summer takes its toll, while a fall treatment will prevent pests from finding a fertile breeding ground in your lawn.

Use John Deere's tow-behind thatcherator to pull up excess thatch.

Selecting the Operating Positions



CAUTION: Avoid injury! Do not operate lift handle unless attachment is installed to tractor.

Lift handle is under tension when using ballast in weight tray. Use caution when moving handle into different positions.

Keep hands and feet away from tines when lowering to the ground.

1. Park tractor safely. (See Parking Safely in the SAFETY section.)
2. Install thatcherator to tractor.

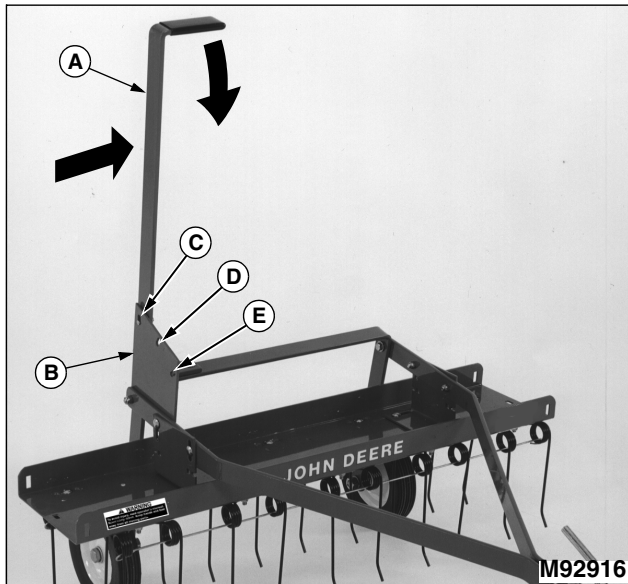

3. Push lift handle (A) toward left side of machine, away from lift lock plate (B).
4. Move handle forward or rearward to engage lock pin into desired position:
 - TRANSPORT (C) - Use top hole to raise tines so unit

can be towed without tines contacting the ground.

- DETHATCH (D) - Use center hole for general dethatching.
- SCARIFY (E) - Use bottom hole to scarify a seed bed.

Using the Weight Tray



CAUTION: Avoid injury! Never add weight to tray unless attachment is installed to tractor.

1. Install thatcherator to tractor.
2. Place lift handle in top hole for transport position.

IMPORTANT: Avoid damage! Never exceed the weight tray capacity of 45 kg (100 lb).

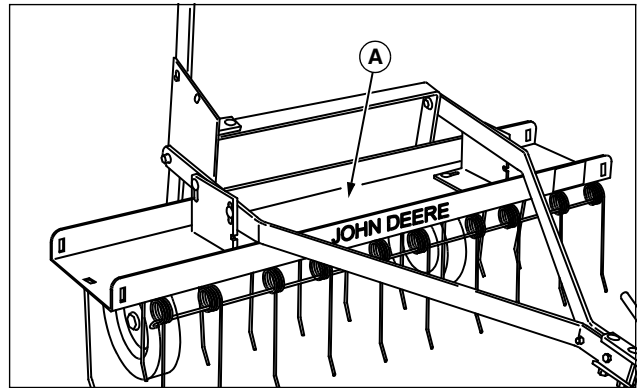

3. Add sand bags, concrete blocks, or other type of weight to weight tray (A). Do not exceed 45 kg (100 lb) of weight. Distribute weight evenly across tray to ensure equal tine pressure.
4. If necessary, secure weight in tray using straps.

Checking for Proper Tine Action

Grass should be less than 76 mm (3 in.) high for proper tine action during dethatching. The lift handle must be in the DETHATCH (center) position.

When in use, all tines on the thatcherator should deflect back and "flip" the thatch forward. If tines seem to drag without flipping forward, the tine tray is too low and should be raised. If all the tines stay in the free position, the tray should be lowered.

If the tines are not moving through the full range of motion, make up or down adjustments as required.

OPERATING - THATCHERATOR

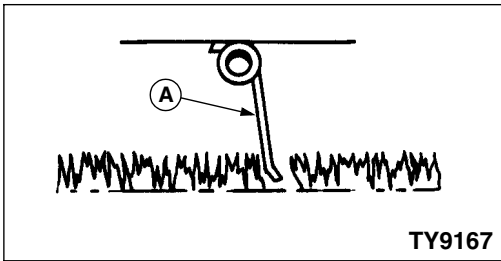

- In free position (A), tines are relaxed and not working.

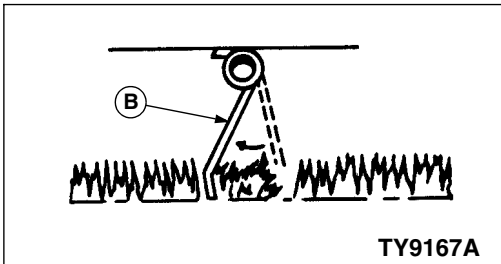

- In position (B), tines are under tension and working.

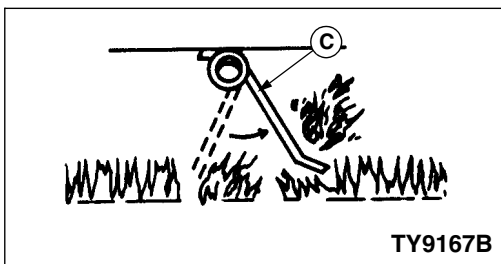

- In position (C), tines are released and flipping thatch upward.

Adjusting for Proper Tine Action

NOTE: Make up or down adjustments by no more than 6.4 mm (1/4 in.) each time, until proper results are achieved.

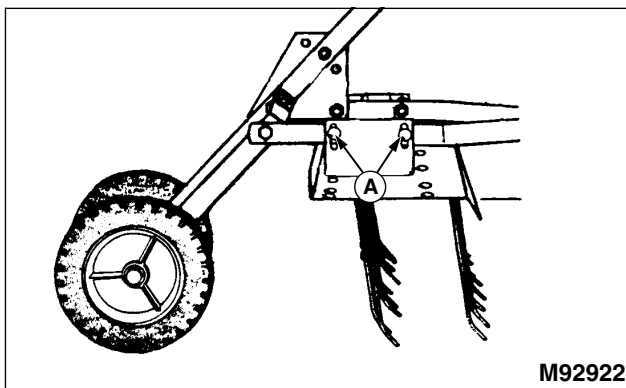

1. Install thatcherator to tractor.
2. Add recommended weight to weight tray.

3. Tow thatcherator to a level concrete or asphalt surface.
4. Park tractor safely. (See Parking Safely in the SAFETY section.)
5. Place lift handle in center hole for detaching position.
6. Loosen bolts (A) on each side of weight tray mounting brackets.
7. Raise or lower weight tray to place tine tips about 13 mm (1/2 in.) above ground surface.
8. Tighten the weight tray bolts completely.
9. Push tines rearward to check adjustment. Tine tips should touch ground surface. If not, repeat the adjustment.

Checking Tractor Ground Speed

- Check ground speed in an open area.
- Measure a test area that is 30.5 m (100 ft) in length.
- Operate the tractor at wide open throttle. Operate tractor at a low speed and drive the tractor the test distance. Record the time needed to travel that distance.
- Make three passes, recording the time for each pass. The average time should be 14 to 23 seconds to achieve the recommended operating speed range:
 - at 4.8 km/h (3 mph), the average time traveling the test distance should be 23 seconds.
 - at 8 km/h (5 mph), the average time traveling the test distance should be 14 seconds.
- Adjust speed accordingly to achieve the recommended speed range.

Operating Thatcherator



CAUTION: Avoid injury! Keep hands and feet away from all moving parts. Never carry riders.

IMPORTANT: Avoid damage! Never exceed the weight tray capacity of 45 kg (100 lb).

Never operate with broken tines or without the safety wires installed through all tine sets.

Engage wheels to transport position when crossing concrete or asphalt surfaces.

Always back carefully in a straight line to avoid jackknifing the attachment.

1. Park tractor safely. (See Parking Safely in the SAFETY section.)

OPERATING - THATCHERATOR

2. Install thatcherator to tractor.
3. Place unit in transport position.
4. Add recommended weight to weight tray.
5. Place unit in desired operating position.
6. Adjust unit to proper depth.
7. Place unit in transport position.
8. Drive to work area.
9. Park tractor safely. (See Parking Safely in the SAFETY section.)
10. Place thatcherator in desired operating position.
11. Start machine.
12. Tow thatcherator at 5 to 8 km/hr (3 to 5 mph) for safe and effective operation.
13. Check for proper tine action. Park tractor safely before making any adjustments.

OPERATING - PLUG AERATOR

When to Use the Plug Aerator

The plug aerator will remove plugs of soil up to 76 mm (3 in.) deep, allowing penetration of water and nutrients for a healthier lawn. It also helps reduce compaction of soil.

Use the plug aerator only on an established lawn, never on newly laid sod. The plug aerator should not be used when lawn conditions are too wet or too dry. To determine condition, dig a small amount of your soil, about 76 mm (3 in.) deep:

- If soil appears powdery and brittle, it is too dry. Wait until a later date, after a rainfall. If soil is too dry, the plugging spoons will not penetrate properly.
- If soil appears damp, attempt to roll a small amount into a ball in the palm of your hand. If it forms a ball, the soil is too wet. Ideally, the soil should fall apart. Wait until the soil is more dry. If the soil is too wet, the plugging spoons will stop up and your tractor could lose traction and damage the lawn.

Selecting the Operating Positions



CAUTION: Avoid injury! Do not operate lift handle unless attachment is installed to tractor.

Lift handle is under tension when using ballast in weight tray. Use caution when moving handle into different positions.

Keep hands and feet away from plugging spoons when lowering to the ground.

1. Park tractor safely. (See Parking Safely in the SAFETY section.)
2. Install plug aerator to tractor.

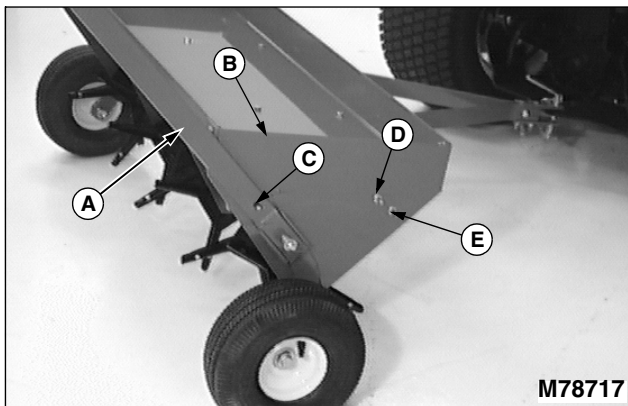

3. Push lift handle (A) toward right side of machine, away from side plate (B).
4. Move handle forward or rearward to engage lock pin into

desired position:

- TRANSPORT (C) - Use top lock pin to raise tines so unit can be towed without plugging spoons contacting the ground.
- OPERATE HIGH (D) - Use middle lock pin for minimum plugging spoon penetration.
- OPERATE LOW (E) - Use lowest lock pin for maximum plugging spoon penetration.

Using the Weight Tray



CAUTION: Avoid injury! Never add weight to tray unless attachment is installed to tractor.

1. Install plug aerator to tractor.
2. Place lift handle in top hole for transport position.

IMPORTANT: Avoid damage! Never exceed the weight tray capacity of 79 kg (175 lb) for 40 in. model, 113 kg (250 lb) for 48 in. model.

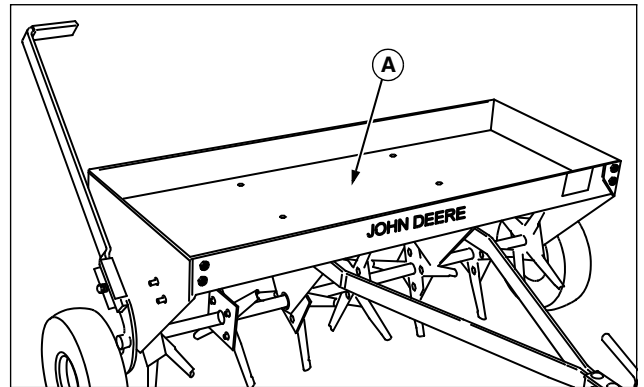

3. Add sand bags, concrete blocks, or other type of weight to weight tray (A). Do not exceed 79.4 kg (175 lb) of weight in 40 in. models, 113.4 kg (250 lb) in 48 in. models. Distribute weight evenly across tray to ensure equal pressure on plugging spoons.
4. If necessary, secure weight in tray using straps.

Checking the Plugging Spoon Operation

Operation of the plugging spoons will vary with soil type, condition, and amount of weight in weight tray. Make sure soil conditions are appropriate for operation. Do not exceed the weight tray capacity to try and improve penetration in overly dry conditions.

Test operation of the plugging spoons by driving the tractor forward about 3 m (10 ft). Observe the operation. A Plug

OPERATING - PLUG AERATOR

hole should appear every 25 to 30 cm (10 to 12 in.) and not more than 76 mm (3 in.) deep.

Add or remove weight to obtain this condition.

9. Tow plug aerator at 5 to 8 km/hr (3 to 5 mph) for safe and effective operation.

10. Check for proper hole pattern and depth. Park tractor safely before making any adjustments.

Checking Tractor Ground Speed

- Check ground speed in an open area.
- Measure a test area that is 30.5 m (100 ft) in length.
- Operate the tractor at wide open throttle. Operate tractor at a low speed and drive the tractor the test distance. Record the time needed to travel that distance.
- Make three passes, recording the time for each pass. The average time should be 14 to 23 seconds to achieve the recommended operating speed range:
 - at 4.8 km/h (3 mph), the average time traveling the test distance should be 23 seconds.
 - at 8 km/h (5 mph), the average time traveling the test distance should be 14 seconds.
- Adjust speed accordingly to achieve the recommended speed range.

Operating Plug Aerator



CAUTION: Avoid injury! Keep hands and feet away from all moving parts. Never carry riders.

IMPORTANT: Avoid damage! Never exceed the weight tray capacity of 79 kg (175 lb) for 40 in. model, 113 kg (250 lb) for 48 in. model.

The 48 in. model is approved for use with GT, 300, and 400 Series lawn and garden tractors only.

Engage wheels to transport position when crossing concrete or asphalt surfaces.

Always back carefully in a straight line to avoid jackknifing the attachment.

1. Park tractor safely. (See Parking Safely in the SAFETY section.)
2. Install plug aerator to tractor.
3. Place unit in transport position.
4. Add recommended weight to weight tray.
5. Drive to work area.
6. Park tractor safely.
7. Place unit in desired operating position.
8. Start machine.

OPERATING - SPIKER AERATOR

When to Use the Spiker Aerator

The spiker aerator will actively penetrate soil, allowing much needed air, water, and nutrients to enter the lawn. It will also relieve soil compaction.

A moderate soil moisture content is important to proper operation of the spiker aerator. Penetration will not occur in extremely dry soil, and very wet conditions will cause the unit to “bog down,” possibly causing lawn damage.

Use the spiker aerator only on an established lawn, never on newly laid sod. The spiker aerator should not be used when lawn conditions are too wet or too dry. To determine condition, dig a small amount of your soil, about 76 mm (3 in.) deep:

- If soil appears powdery and brittle, it is too dry. Wait until a later date, after a rainfall.
- If soil appears damp, roll a small amount into a ball in the palm of your hand, if it forms a ball, then it is too wet. Ideally, the soil should fall apart when rolled in the palm of your hand. Wait till a later date for soil to dry. If soil is too wet, the aerator tines will penetrate too deep and your tractor could lose traction, causing lawn damage. If soil is too dry, the aerator tines will not penetrate soil properly.

Selecting the Operating Positions



CAUTION: Avoid injury! Do not operate lift handle unless attachment is installed to tractor.

Lift handle is under tension when using ballast in weight tray. Use caution when moving handle into different positions.

Keep hands and feet away from tines when lowering to the ground.

1. Park tractor safely. (See Parking Safely in the SAFETY section.)
2. Install spiker aerator to tractor.

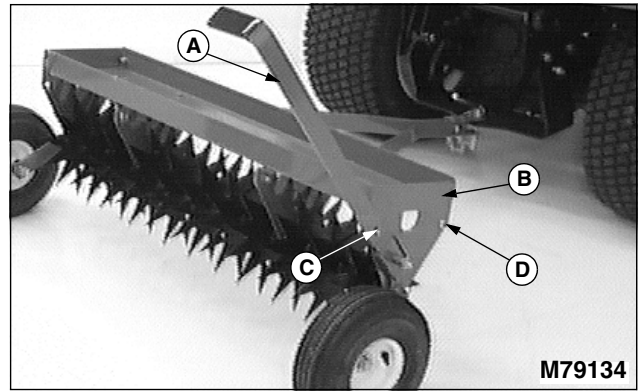

3. Push lift handle (A) toward right side of machine, away from side plate (B).
4. Move handle forward or rearward to engage lock pin into desired position:
 - **TRANSPORT (C)** - Use rear lock pin to raise tines so unit can be towed without tines contacting the ground.
 - **OPERATE (D)** - Use front lock pin to lower tines to ground for operation.

Using the Weight Tray



CAUTION: Avoid injury! Never add weight to tray unless attachment is installed to tractor.

1. Install spiker aerator to tractor.
2. Place lift handle in rear hole for transport position.

IMPORTANT: Avoid damage! Never exceed the weight tray capacity of 45 kg (100 lb).

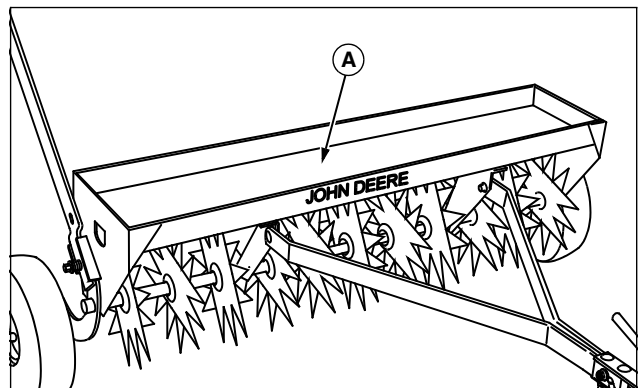

3. Add sand bags, concrete blocks, or other type of weight to weight tray (A). Do not exceed 45 kg (100 lb) of weight. Distribute weight evenly across tray to ensure equal pressure on tines.
4. If necessary, secure weight in tray using straps.

OPERATING - SPIKER AERATOR

Checking the Tine Operation

Operation of the tines will vary with soil type, condition, and amount of weight in weight tray. Make sure soil conditions are appropriate for operation. Do not exceed the weight tray capacity to try and improve penetration in overly dry conditions.

Test operation of the tines by driving the tractor forward about 3 m (10 ft). Observe the operation. Check for uniform hole pattern and depth.

Add, remove, or distribute the weight better to obtain proper results.

Periodically, check the tines. Remove any debris build up that might restrict or cause damage to the tines.

section.)

2. Install spiker aerator to tractor.
3. Place unit in transport position.
4. Add recommended weight to weight tray.
5. Drive to work area.
6. Park tractor safely.
7. Place unit in operating position.
8. Start machine.
9. Tow spiker aerator at 5 to 8 km/hr (3 to 5 mph) for safe and effective operation.
10. Check for uniform hole pattern and depth. Park tractor safely before making any adjustments.

Checking Tractor Ground Speed

- Check ground speed in an open area.
- Measure a test area that is 30.5 m (100 ft) in length.
- Operate the tractor at wide open throttle. Operate tractor at a low speed and drive the tractor the test distance. Record the time needed to travel that distance.
- Make three passes, recording the time for each pass. The average time should be 14 to 23 seconds to achieve the recommended operating speed range:
 - at 4.8 km/h (3 mph), the average time traveling the test distance should be 23 seconds.
 - at 8 km/h (5 mph), the average time traveling the test distance should be 14 seconds.
- Adjust speed accordingly to achieve the recommended speed range.

Operating Spiker Aerator



CAUTION: Avoid injury! Keep hands and feet away from all moving parts. Never carry riders.

IMPORTANT: Avoid damage! Never exceed the weight tray capacity of 45 kg (100 lb).

Engage wheels to transport position when crossing concrete or asphalt surfaces.

Always back carefully in a straight line to avoid jackknifing the attachment.

Periodically remove debris build up that can restrict or damage the tines.

1. Park tractor safely. (See Parking Safely in the SAFETY

OPERATING - AERATOR-SPREADER

When to Use the Aerator-Spreader

The aerator-spreader will actively penetrate soil, allowing much needed air, water, and nutrients to enter the lawn. It will also relieve soil compaction and can be used to spread seed or fertilizer while aerating.

A moderate soil moisture content is important to proper operation of the aerator-spreader. Penetration will not occur in extremely dry soil, and very wet conditions will cause the unit to “bog down,” possibly causing lawn damage.

Use the aerator-spreader only on an established lawn, never on newly laid sod. The aerator-spreader should not be used when lawn conditions are too wet or too dry. To determine condition, dig a small amount of your soil, about 76 mm (3 in.) deep:

- If soil appears powdery and brittle, it is too dry. Wait until a later date, after a rainfall.
- If soil appears damp, roll a small amount into a ball in the palm of your hand, if it forms a ball, then it is too wet. Ideally, the soil should fall apart when rolled in the palm of your hand. Wait till a later date for soil to dry. If soil is too wet, the aerator tines will penetrate too deep and your tractor could lose traction, causing lawn damage. If soil is too dry, the aerator tines will not penetrate soil properly.

Selecting the Operating Positions



CAUTION: Avoid injury! Do not operate lift handle unless attachment is installed to tractor.

Lift handle is under tension when using ballast in weight tray or material in hopper. Use caution when moving handle into different positions.

Keep hands and feet away from tines when lowering to the ground.

1. Park tractor safely. (See Parking Safely in the SAFETY section.)
2. Install aerator-spreader to tractor.

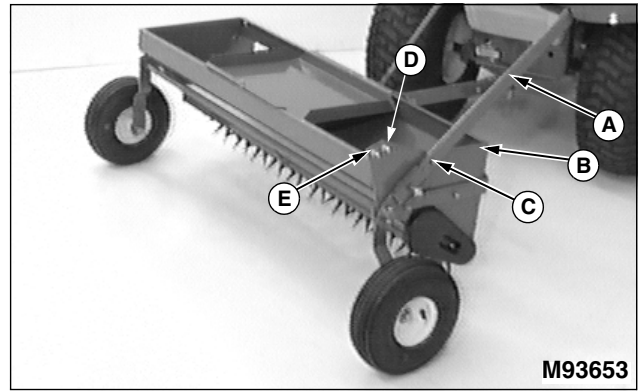

3. Push lift handle (A) toward right side of machine, away from side plate (B).

4. Move handle forward or rearward to engage lock pin into desired position:

- **TRANSPORT (C)** - Use front lock pin to raise tines so unit can be towed without tines contacting the ground.
- **OPERATE HIGH (D)** - Use middle lock pin for minimum tine penetration.
- **OPERATE LOW (E)** - Use rear lock pin for maximum tine penetration.

Using the Flow Control

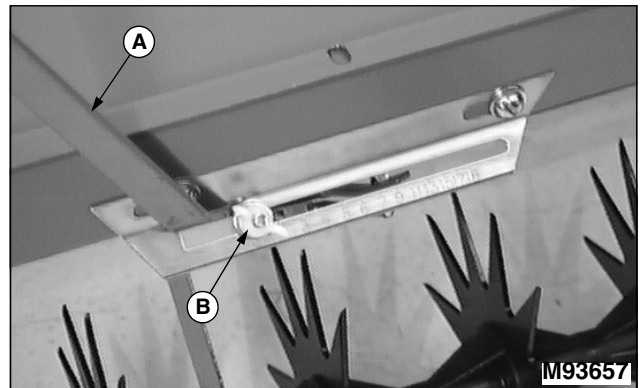

Open/Close Hopper

Move flow control lever (A) to the left and lock into V-notch on calibration plate to shut off material flow. Unlock lever to open hopper and allow material flow.

Adjust Flow Rate

1. Determine the correct flow rate setting for your spreading application.
2. Loosen flow control adjustment stop (B).
3. Slide adjustment stop to desired flow rate setting.
4. Tighten the adjustment stop.

OPERATING - AERATOR-SPREADER

5. Unlock the flow control lever. It will open the hopper to the pre-set flow rate setting.

Using the Weight Tray and Hopper



CAUTION: Avoid injury! Never add weight to tray or material to hopper unless attachment is installed to tractor.

1. Install aerator-spreader to tractor.
2. Place lift handle in front hole for transport position.

IMPORTANT: Avoid damage! Never exceed the total weight capacity of 68 kg (150 lb) or the individual weight capacities of the weight tray and hopper.

- Weight Tray – 34 kg (75 lb).
- Hopper – 34 kg (75 lb).

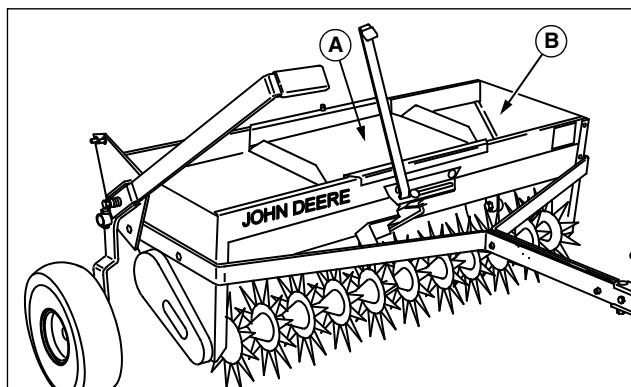

3. Add sand bags, concrete blocks, or other type of weight to weight tray (A). Do not exceed 34 kg (75 lb) of weight in the tray.
4. If necessary, secure weight in tray using straps.
5. Fill hopper (B) with desired material. Do not exceed 34 kg (75 lb) of weight in the hopper.

Checking the Tine and Spreader Operation

Operation of the tines will vary with soil type, condition, and amount of weight in unit. Make sure soil conditions are appropriate for operation. Do not exceed the weight tray or hopper capacities to try and improve penetration in overly dry conditions.

Aerating tines must be in the lowered position in order for the aerator-spreader to operate. Agitator is driven off of the aerator tines.

Test operation of the tines and spreader by driving the

tractor forward about 3 m (10 ft). Observe the operation. Check for uniform hole pattern, depth, and spread.

Add or remove weight if needed to obtain proper aeration results. Adjust ground speed and/or flow control setting to achieve proper spreading results.

Fertilizer application rates can be affected by humidity and the amount of moisture in the material. Poor spreading results can occur if the material has been allowed to become wet or packed in the hopper.

Avoid stopping unit with flow control in open position, material will continue to flow through hopper opening. If fertilizer is deposited too heavily in a small area, soak down thoroughly with a garden hose to prevent burning of lawn.

Periodically, check the tines. Remove any debris build up that might restrict or cause damage to the tines.

Determining the Flow Control Setting

NOTE: Fertilizer application rates as provided are affected by humidity and moisture content of the material. Minor setting adjustments may be necessary to compensate for these conditions.

APPLICATION RATE CHART

Material Type	Average Recommended Usage	Flow Control Setting
Kentucky Bluegrass Seed	.49 kg/100 m ² (1 lb/1000 sq ft)	4
Rye Seed	.96 kg/100 m ² (2 lb/1000 sq ft)	7
Tall Lawn & #31 Fescue	1.44 kg/100 m ² (3 lb/1000 sq ft)	12
10-10-10 Fertilizer	24.4 kg/500 m ² (50 lb/5000 sq ft)	9
10-18-10 (Winter Green 2 Way) Fertilizer	29.3 kg/2000 m ² (60 lb/20000 sq ft)	5

Determining the Flow Control Setting (Alternative Method)

To determine the required setting for materials not listed on the APPLICATION RATE CHART, proceed using the following Metric or English example:

OPERATING - AERATOR-SPREADER

Metric Applications

1. Determine from material bag, the amount of material to be spread over a designated area. Example: The contents of this bag, 11 kg, will cover 465 m².
2. Determine the amount of material required to cover 10 m² as follows:
 - Add one zero to the bag weight. Example: 110 kg.
 - Divide this number by the number of square meters on the bag. Example: 110 divided by 465 = 0.24 kg of material for 10 m². To convert this weight to grams, multiply by 1000 (1000 g /kg). Example: 0.24 kg x 1000 = 240 grams.
3. Determine approximate Flow Control Setting by using the following ALTERNATIVE FLOW CONTROL SETTING CHART showing type of material to spread.
4. Measure a distance of 10 m in your yard. This is the distance your 40 in. spreader must travel in order to cover 10 m².
5. Set spreader flow control at the approximate flow control setting.
6. Place 2.3 kg of material in hopper. Weigh the material before and after spreading 10 m² to determine amount of material used.
7. Move unit to measured area, lower the aerator tines, and open the flow control lever. Drive the 10 m² course, stop unit, and close the flow control lever.
8. Remove and weigh remaining material. Subtract this weight from 2.3 kg to determine material used. If too much material is used, set Flow Control ONE number LOWER and try again. If too little material is used, set Flow Control ONE number HIGHER and try again.
9. After determining proper setting always record the type of material and the setting for future use.

English Applications

1. Determine from material bag, the amount of material to be spread over a designated area. Example: The contents of this bag, 25 lb, will cover 5000 sq ft.
2. Determine the amount of material required to cover 100 sq ft as follows:
 - Add two zeros to the bag weight. Example: 2500 lb.
 - Divide this number by the number of square feet on the bag. Example: 2500 divided by 5000 = 0.5 lb of material for 100 sq ft. To convert this weight to ounces, multiply by 16 (16 oz/lb). Example: 0.5 lb x 16 = 8 oz.
3. Determine approximate Flow Control Setting by using the following ALTERNATIVE FLOW CONTROL SETTING CHART showing type of material to spread.
4. Measure off a distance of 30 ft in your yard. This is the

distance your 40 in. spreader must travel in order to cover 100 sq ft.

5. Set the spreader flow control at the approximate flow control setting.
6. Place 5 lb of material in hopper. Weigh the material before and after spreading 100 sq ft to determine amount of material used.
7. Move unit to measured area, lower the aerator tines, and open the flow control lever. Drive the 30 ft course, stop unit, and close the flow control lever.
8. Remove and weigh remaining material. Subtract this weight from 5 lb to determine material used. If too much material is used, set Flow Control ONE number LOWER and try again. If too little material is used, set Flow Control ONE number HIGHER and try again.
9. After determining proper setting always record the type of material and the setting for future use.

ALTERNATIVE FLOW CONTROL SETTING CHART		
Material Coarseness	Approximate Coverage	Approximate Flow Control Setting
Large Seeds (#31 Fescue, etc.)	.15 kg/10 m ² (.3 lb/100 sq ft)	12
	.24 kg/10 m ² (.5 lb/100 sq ft)	16
	.34 kg/10 m ² (.7 lb/100 sq ft)	19
Medium Seeds (Rye, etc.)	.10 kg/10 m ² (.2 lb/100 sq ft)	7
	.19 kg/10m ² (.4 lb/100 sq ft)	11
	.29 kg/10 m ² (.6 lb/100 sq ft)	14
Fine Seeds (Bluegrass, Lawn Fescue, etc.)	.05 kg/10 m ² (.1 lb/100 sq ft)	4
	.10 kg/10 m ² (.2 lb/100 sq ft)	4-1/2
	.15 kg/10 m ² (.3 lb/100 sq ft)	5

OPERATING - AERATOR-SPREADER

ALTERNATIVE FLOW CONTROL SETTING CHART		
Very Coarse Fertilizers (Large, heavy pellets and granules)	.24 kg/10 m ² (.5 lb/100 sq ft)	9
	.49 kg/10 m ² (1.0 lb/100 sq ft)	12
	.73 kg/10 m ² (1.5 lb/100 sq ft)	15
Medium Coarse Fertilizers (Pellets and granules)	.24 kg/10 m ² (.5 lb/100 sq ft)	7
	.49 kg/10 m ² (1.0 lb/100 sq ft)	10
	.73 kg/10 m ² (1.5 lb/100 sq ft)	13
Light Fertilizers (Nitrogen, etc.)	.05 kg/10 m ² (.1 lb/100 sq ft)	3-1/2
	.10 kg/10 m ² (.2 lb/100 sq ft)	4-1/2
	.15 kg/10 m ² (.3 lb/100 sq ft)	5-1/2

Operating Aerator-Spreader



CAUTION: Avoid injury! Keep hands and feet away from all moving parts. Never carry riders.

IMPORTANT: Avoid damage! Never exceed the weight tray capacity of 45 kg (100 lb).

Engage wheels to transport position when crossing concrete or asphalt surfaces.

Always back carefully in a straight line to avoid jackknifing the attachment.

Periodically remove debris build up that can restrict or damage the tines.

1. Park tractor safely. (See Parking Safely in the SAFETY section.)

2. Install aerator-spreader to tractor.

3. Place unit in transport position.

4. Add recommended weight to weight tray.

NOTE: Do not fill hopper and transport over long distances without dropping material. This will result in packing the material, causing poor or erratic discharge. Fill hopper only at operation site.

5. Drive to work area for filling of hopper.

6. Park tractor safely.

7. Lock the flow control lever in the closed position.

8. Set the flow control rate to proper setting.

9. Fill hopper with material to be spread. Break up all lumps while filling.

10. Place unit in desired operating position.

11. Start machine.

12. Drive tractor forward and unlock the flow control lever to begin aerating and spreading.

13. Tow aerator-spreader at 5 to 8 km/hr (3 to 5 mph) for safe and effective operation.

14. Check for uniform hole pattern and depth. Close the flow control lever and park tractor safely before making any adjustments.

Checking Tractor Ground Speed

- Check ground speed in an open area.
- Measure a test area that is 30.5 m (100 ft) in length.
- Operate the tractor at wide open throttle. Operate tractor at a low speed and drive the tractor the test distance. Record the time needed to travel that distance.
- Make three passes, recording the time for each pass. The average time should be 14 to 23 seconds to achieve the recommended operating speed range:
 - at 4.8 km/h (3 mph), the average time traveling the test distance should be 23 seconds.
 - at 8 km/h (5 mph), the average time traveling the test distance should be 14 seconds.
- Adjust speed accordingly to achieve the recommended speed range.

OPERATING - LAWN ROLLER

When to Use the Lawn Roller

Use the lawn roller at any time to pack down new sod, seed, and unlevel ground.

Adding Weight to the Lawn Roller



CAUTION: Avoid injury! Never add weight to lawn roller unless unit is installed to tractor.

Do not overload your tractor. Fully loaded roller can weigh 177 kg (390 lb).

1. Install lawn roller to tractor.

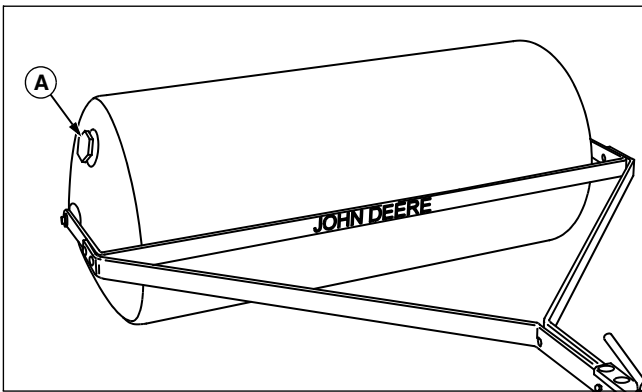

2. Remove plug (A).
3. Fill roller with water or sand.

IMPORTANT: Avoid damage! Threaded plug might start hard. Use care not to strip or cross-thread the plug.

4. Install and tighten plug securely.

Operating Lawn Roller Safely

- DO NOT overload your tractor. Fully loaded roller can weigh 176.9 kg (390 lb).
- Refer to tractor manual to determine proper towing capacity of your tractor.
- When backing, carefully back straight to avoid jackknifing which could result in damage to equipment.
- Stay alert for holes in the terrain and other hidden hazards.
- Do not drive close to creeks, ditches and public highways.
- Watch out for traffic when crossing or near roadways.
- Only tow your Lawn Roller behind vehicles for which it

was designed – lawn tractors and lawn and garden tractors.

Checking Tractor Ground Speed

- Check ground speed in an open area.
- Measure a test area that is 30.5 m (100 ft) in length.
- Operate the tractor at wide open throttle. Operate tractor at a low speed and drive the tractor the test distance. Record the time needed to travel that distance.
- Make three passes, recording the time for each pass. The average time should be 14 to 23 seconds to achieve the recommended operating speed range:
 - at 4.8 km/h (3 mph), the average time traveling the test distance should be 23 seconds.
 - at 8 km/h (5 mph), the average time traveling the test distance should be 14 seconds.
- Adjust speed accordingly to achieve the recommended speed range.

Operating Lawn Roller



CAUTION: Avoid injury! Keep hands and feet away from all moving parts. Never carry riders.

IMPORTANT: Avoid damage! Always back carefully in a straight line to avoid jackknifing the attachment.

1. Park tractor safely. (See Parking in the SAFETY section.)
2. Install lawn roller to tractor.
3. Fill roller with water or sand.
4. Drive tractor to work area.
5. Tow lawn roller at 5 to 8 km/hr (3 to 5 mph) for safe and effective operation.

SERVICE

Servicing the Attachment



CAUTION: Avoid injury! Plugging spoons and tines are sharp. Wear gloves and handle with care. Shield sharp parts during service work.

To prevent or eliminate rust on tines or plugging spoons, apply a light oil on them after each use.

For rust appearing on any part of your attachment, sand lightly and coat with enamel.

Apply a drop of lubricating oil to each nylon/tine bearing assembly, axles, and working areas of the plugging spoons before each use.

Periodically check the aerating tines or plugging spoons. Remove any debris that might build up and restrict their action.

Periodically check tightness of all fasteners.

Be sure to remove all unused fertilizers from hopper immediately after use and clean with water to prevent corrosion.

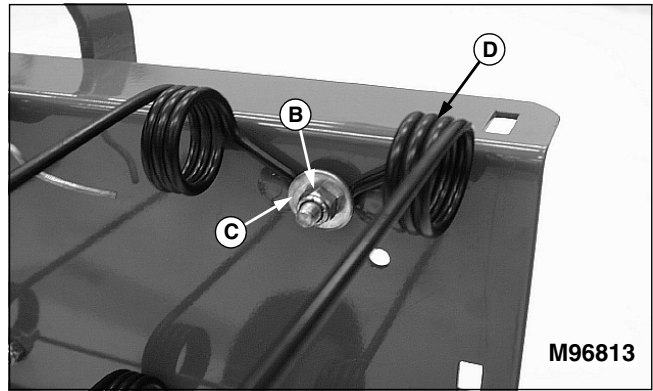

3. Remove and retain locknut (B) and washer (C). Then remove and discard the damaged tine set.
4. Install new tine set making sure tine tips are pointed in same direction as the other tines on the unit. Secure with original hardware.
5. Slide safety wire through all tine coils. Bend ends of safety wire over last coil (D) at each end of unit.

Replacing Thatcherator Tines

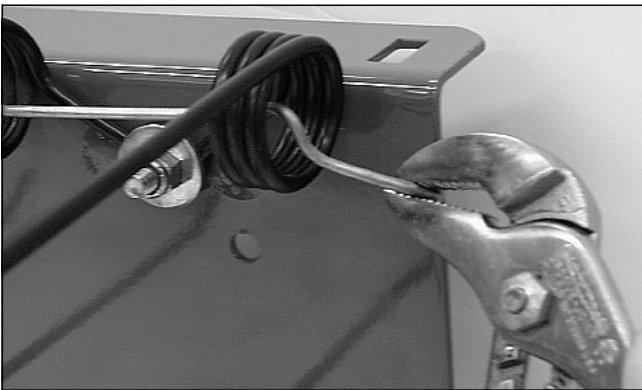

1. Straighten end of retention safety wire (A) with pliers.
2. Remove safety wire from damaged tine set.

STORAGE

Storing the Attachment



CAUTION: Avoid injury! Plugging spoons and tines are sharp. Wear gloves and handle with care. Store attachments so sharp parts are shielded from contact.

1. Park tractor safely. (See Parking Safely in the SAFETY section.)
2. Remove all weight and material from attachment.
3. Remove attachment from tractor.
4. Wash attachment thoroughly. Allow to dry completely.
5. Replace all worn, damaged, or missing parts.
6. Sand any rusted areas lightly and paint with enamel.
7. Lubricate moving parts.
8. Apply a light coverage of oil to all tines and plugging spoons to prevent rust.
9. Reduce air pressure in tires.
10. Store attachment in a dry area with tines against wall or floor to avoid accidental contact.
11. Block up attachment off the ground to prevent contact with moisture and take weight of the tires.
12. Place a waterproof cover over the attachment if it must be stored outside.

Removing the Attachment from Storage



CAUTION: Avoid injury! Plugging spoons and tines are sharp. Wear gloves and handle with care. Store attachments so sharp parts are shielded from contact.

1. Wash the attachment if necessary. Allow to dry completely.
2. Inspect tires for deterioration.
3. Inflate tires to proper pressure.
4. Make sure all parts are in place and hardware is secure.

ASSEMBLY - THATCHERATOR

Identify Parts

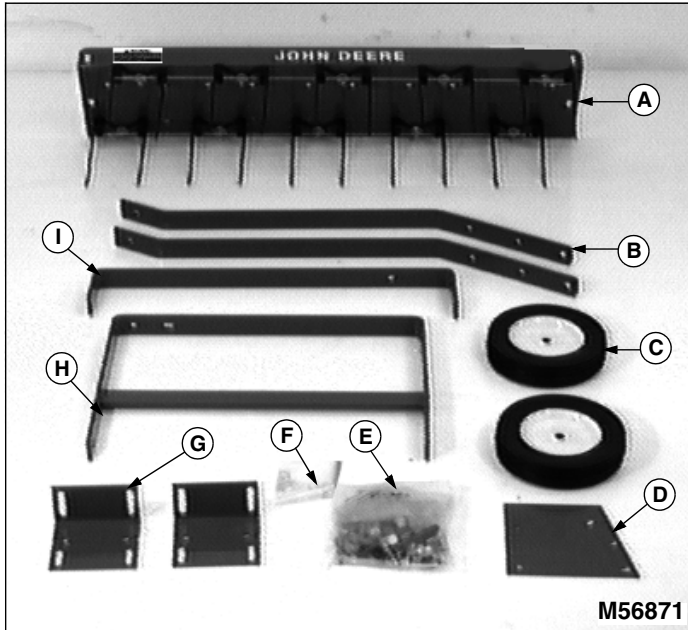

Box of Parts

Qty.	Part Description
1	Tray Assembly (A)
2	Tow Bar (B)
2	Wheel Assembly (C)
1	Lock Plate (D)
1	Bag of Parts (E)
1	Tethered Pin Assembly (F)
2	Mounting Bracket (G)
1	Carriage Frame (H)
1	Lift Handle (I)

Bag of Parts

Qty.	Part Description
1	Vinyl Handle Grip
2	Plated Pivot Bushing, 3/8 in.
2	Painted Clevis
1	Spring
2	Carriage Bolt, 5/16 x 1-1/4 in.
1	Hex Bolt, 5/16 x 1-1/2 in.

Qty.	Part Description
1	Carriage Bolt, 5/16 x 2 in.
2	Carriage Bolt, 5/16 x 2-1/4 in.
1	Hex Bolt, 3/8 x 1-1/4 in.
1	Hex Bolt, 3/8 x 1-1/2 in.
2	Hex Bolt, 5/8 x 3-1/4 in.
4	Hex Nut, 5/8 in.
2	Lockwasher, 5/8 in.
2	Flat Washer, 5/16 in.
2	Flat Washer, 3/8 in.
4	Flat Washer, 5/8 in.
2	Hex Locknut, 3/8 in.
1	Hex Nut, 5/16 in.
1	Lockwasher, 5/16 in.
1	Lift Lock Pin
7	Carriage Bolt, 5/16 x 1 in.
13	Hex Nuts w/Nylon Insert, 5/16 in.

Assemble Tow Bars

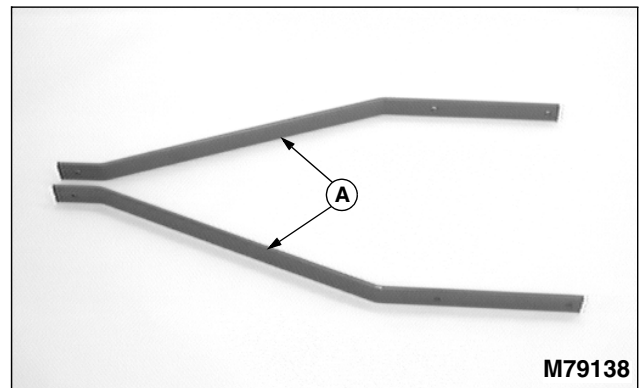

1. Align tow bars (A) as shown.

ASSEMBLY - THATCHERATOR

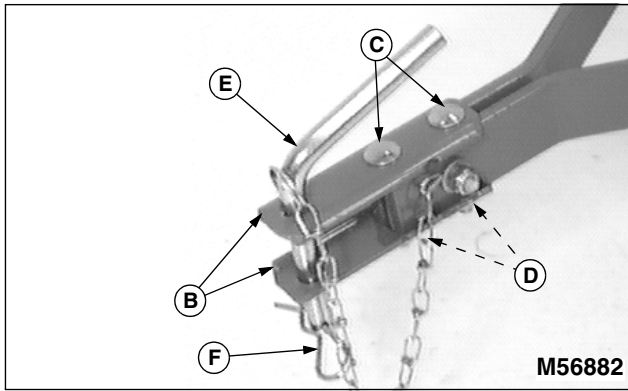

2. Assemble two clevis straps (B) to front of tow bars using two 5/16 x 2-1/4 in. carriage bolts (C) and two locknuts (D). Hand tighten only.

3. Slide clevis assembly forward until front carriage bolt is within 6 mm (1/4 in.) from the end of tow bars.

4. Install hitch pin (E) in clevis and fasten with spring locking pin (F) through chain loop.

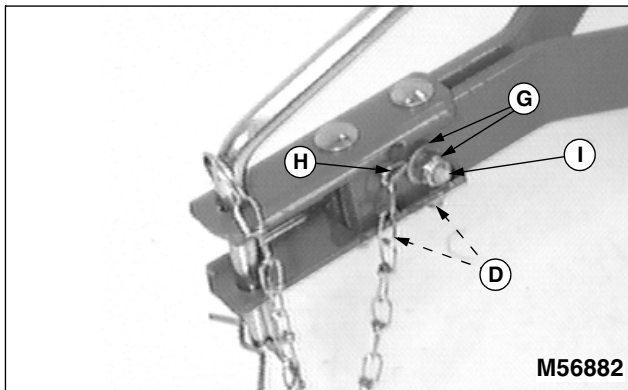

5. Install 5/16 x 1-1/2 in. cross hex bolt (I). Place chain hook (H) around bolt and secure with 5/16 in. flat washer and locknut (I).

6. Align tow bars and clevis. Tighten nuts (D) completely.

7. Tighten nylock nut (G) while holding chain hook forward and centered between clevis halves.

Install Tow Bars to Tray Assembly

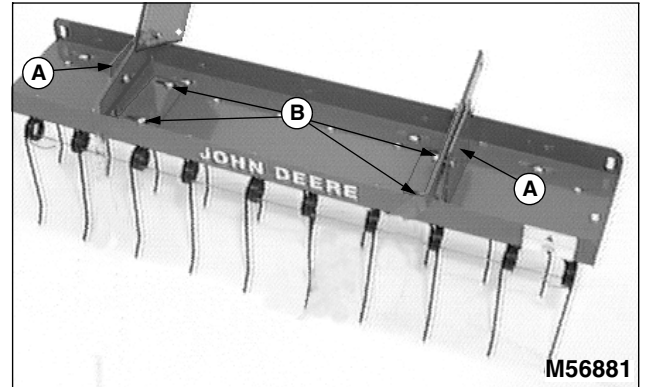

1. Using second set of holes on left side of tray and third set of holes on right side of tray, fasten two mounting brackets (A) to the tine tray with the small flange resting on the tray surface and facing inward. Secure with four 5/16 x 1 in. carriage bolts and hex nuts (B). Hand tighten only.

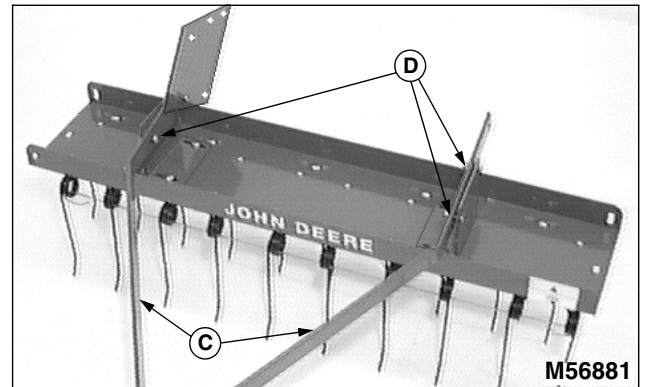

2. Attach tow bars (C) to the inside surfaces of the mounting brackets using three 5/16 x 1 in. carriage bolts and locknuts (D). Hand tighten only.

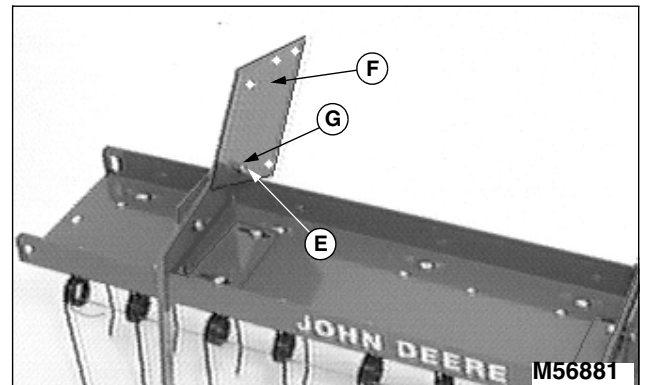

3. Align hole (E) in the lift lock plate (F) with holes in the right tow bar and mounting bracket. Attach the lift lock plate to the inside of the tow bar with a 5/16 x 1-1/4 in. carriage bolt and locknut (G). Hand tighten only.

ASSEMBLY - THATCHERATOR

Install Carriage Frame Assembly and Lift Handle

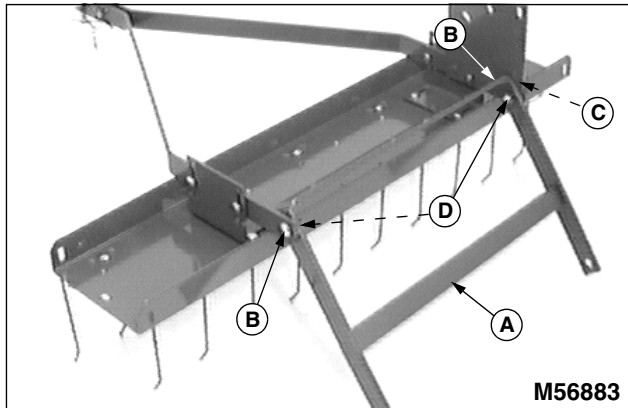

1. Attach carriage frame assembly (A) (side with two holes should be next to lift lock plate) to rear holes (B) in tow bars and lift lock plate at right side (C). Secure with 3/8 x 1-1/4 in. hex bolt (left side) and 3/8 x 1-1/2 in. (right side lift lock plate), 3/8 in. bushings, 3/8 in. flat washers, and fasten with 3/8 in. locknuts (D). Tighten so bar is secure but free to pivot.

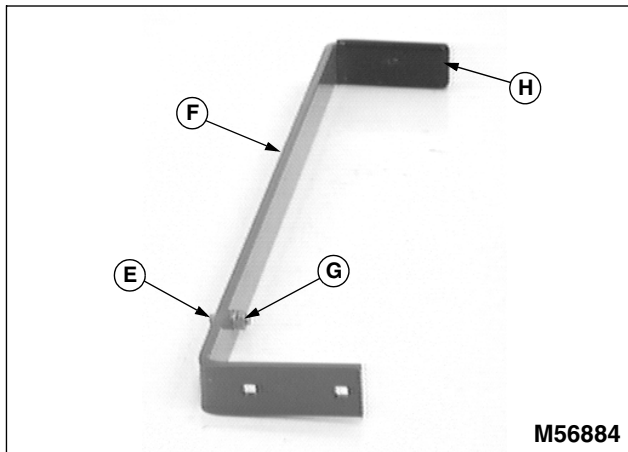

2. Pre-assemble lift lock pin (E) into hole in lift handle (F) with pin extending away from bend in lift handle. Secure with 5/16 in. lockwasher and 5/16 in. hex nut (G). Tighten securely.
3. Slide vinyl handle grip (H) over end of lift handle.

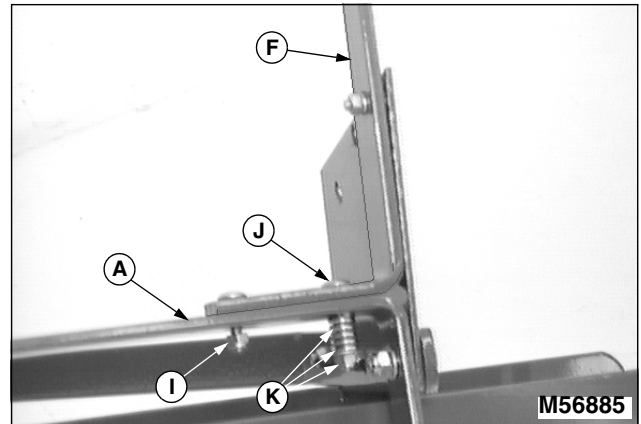

4. Attach the lift handle (F) to holes in top of carriage frame (A) using one 5/16 x 1-1/4 in. carriage bolt and locknut (I) and one 5/16 x 2 in. carriage bolt (J), spring, flat washer, and locknut (K).
5. Push the lift handle against lift lock plate and tighten bolts until locknuts have two bolt threads exposed.

Install Wheels

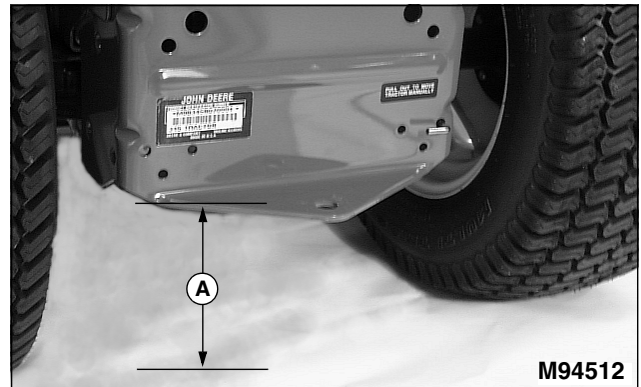

1. Measure length (A) from ground to top of hitch plate with tractor parked on a level surface.

ASSEMBLY - THATCHERATOR

NOTE: If length (A) is 22.9 cm (9 in.) or more, wheel is attached at top hole shown in wheel strap (B). Use lower hole if length is less.

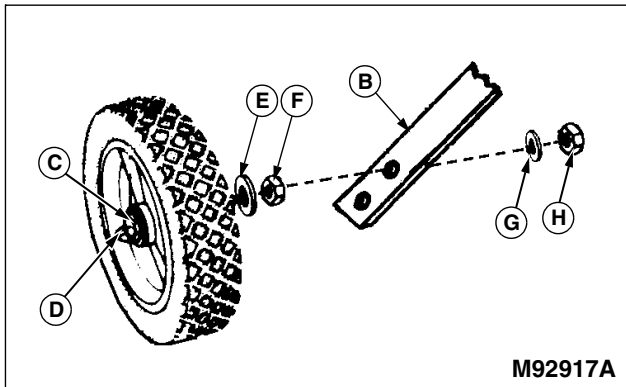

2. Install one 5/8 in. flat washer (C) onto 5/8 x 3 in. hex bolt (D).
3. Slide wheel onto bolt so side with flat hub surface (not rounded) is seated against washer and bolt head.
4. Install 5/8 in. flat washer (E) and 5/8 in. hex nut (F) onto threaded end of bolt. Tighten nut enough so the wheel can still spin freely.
5. Install wheel assembly to outside of wheel strap (B) using top or bottom hole as required. Secure with lockwasher (G) and 5/8 in. hex nut (H).
6. Hold a wrench on nut (F) and tighten nut (H) completely.
7. Repeat for other wheel assembly.

ASSEMBLY - PLUG AERATOR

Identify Parts

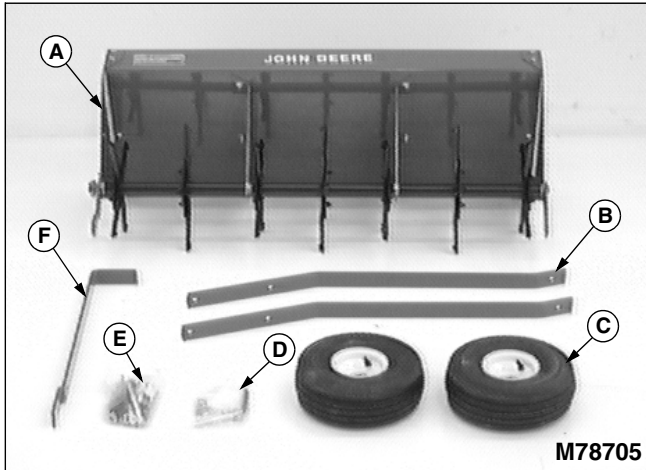

Picture Note: 40-Inch model shown.

NOTE: The following assembly instructions apply to both the 40-Inch and 48-Inch models.

Box of Parts

Qty.	Part Description
1	Plug Tray Assembly (A)
2	Tow Bar (B)
2	Wheel Assembly (C)
1	Hitch Pin Assembly (D)
1	Bag of Parts (E)
1	Lift Handle (F)

Bag of Parts

Qty.	Part Description
3	Transport Pin, 5/16 in.
2	Carriage Bolt, 5/16 x 2 1/4 in.
1	Flat-Top Carriage Bolt, 3/8 x 2 in.
4	Hex Bolt, 5/16 x 1 in.
1	Hex Bolt, 5/16 x 1-1/2 in.
2	Hex Bolt, 1/2 x 3-3/4 in.
3	Hex Nut, 5/16 in.
4	Hex Nut, 1/2 in.
1	Oblong Locknut, 3/8 in.

Qty.	Part Description
7	Nylock Nut, 5/16 in.
3	Medium Lockwasher, 5/16 in.
2	Medium Lockwasher, 1/2 in.
5	Flat Washer, 11/32 x 11/16 x 1/16 in.
1	Flat Washer, 13/32 x 13/16 x 1/16 in.
4	Flat Washer, 17/32 x 1/16 x 3/32 in.
1	Vinyl Handle Grip
2	Clevis
1	Spring

Assemble Tow Bars

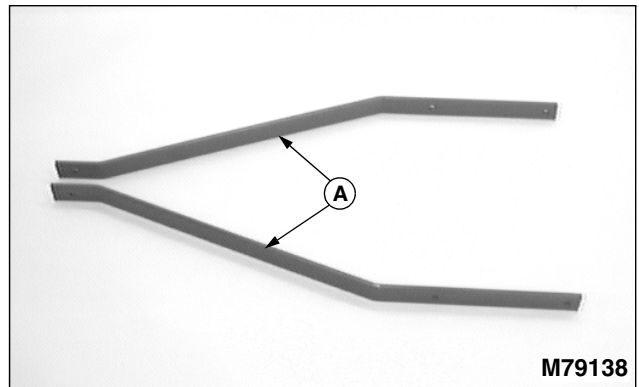

1. Align tow bars (A) as shown.

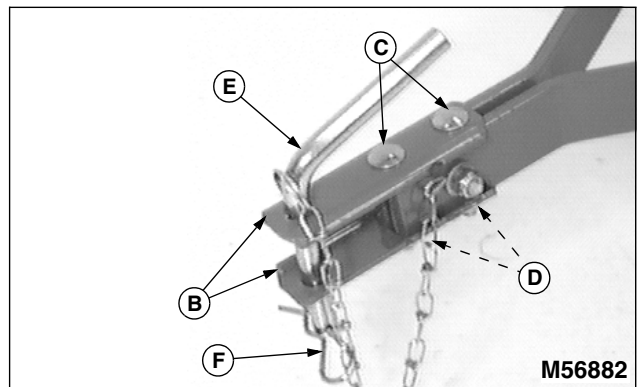

2. Assemble two clevis straps (B) to front of tow bars using two 5/16 x 2-1/4 in. carriage bolts (C) and two locknuts (D). Hand tighten only.
3. Slide clevis assembly forward until front carriage bolt is within 6 mm (1/4 in.) from the end of tow bars.
4. Install hitch pin (E) in clevis and fasten with spring locking pin (F) through chain loop.

ASSEMBLY - PLUG AERATOR

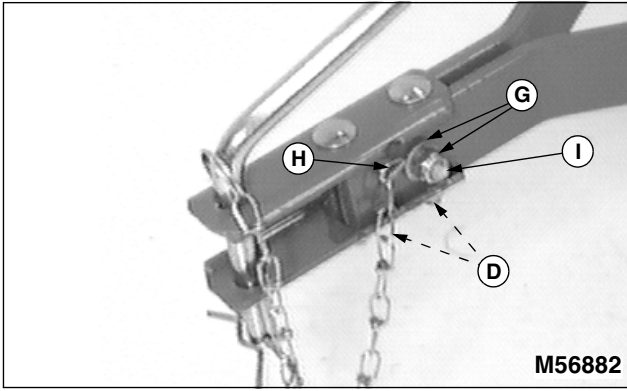

5. Install 5/16 x 1-1/2 in. cross hex bolt (I). Place chain hook (H) around bolt and secure with 5/16 in. flat washer and locknut (I).
6. Align tow bars and clevis. Tighten nuts (D) completely.
7. Tighten nylock nut (G) while holding chain hook forward and centered between clevis halves.

Install Tow Bars to Tray Assembly



CAUTION: Avoid injury! Plug spoons have sharp edges. Wear gloves and handle with care.

1. Stand plug tray assembly on its rear side.

NOTE: You may want to get a helper or use a hoist to steady tow bars during alignment.

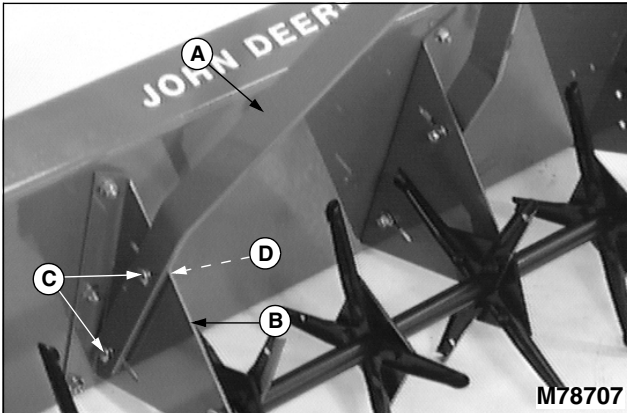

2. Align tow bars (A) to outside of brackets (B) and fasten with two 5/16 x 1 in. hex bolts (C). Secure with 11/32 x 11/16 x 1/16 in. flat washers and nylock nuts (D) to the inside of the bracket. Hand tighten only. Repeat for other side.
3. Hold tow bars all the way to top of slots and tighten nylock nuts (D).

Install Lift Lever



CAUTION: Avoid injury! Plug Spoons have sharp points. Wear gloves and handle with care.

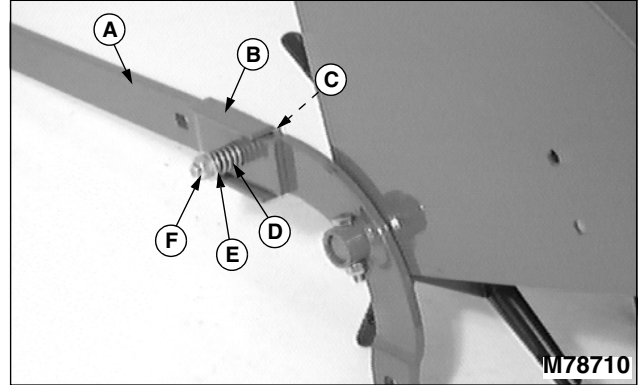

1. Slide lift handle (A) into lift arm channel (B). Lift handle offset goes to outside of lift arm.
2. Install 3/8 x 2 in. flat-top carriage bolt (C) with bolt head to inside of lift arm. Slide spring (D) and 13/32 x 13/16 x 1/16 in. flat washer (E) onto bolt.

NOTE: Make sure bolt head (C) is properly seated when tightening locknut.

3. Install and tighten locknut (F) until one full thread is exposed.

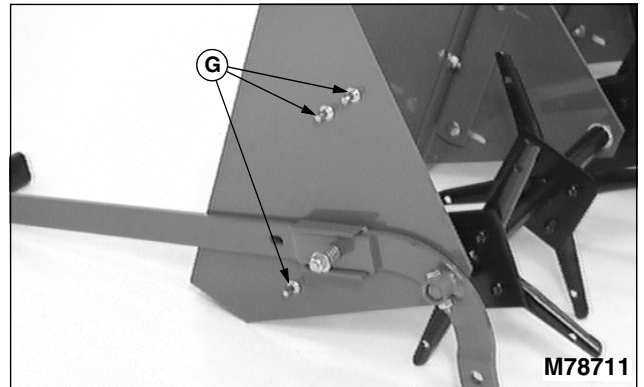

4. Install three transport pins (G) with threaded end to the inside. Secure with 5/16 in. lockwashers and 5/16 in. hex nuts on the inside. Tighten nuts completely.

ASSEMBLY - PLUG AERATOR

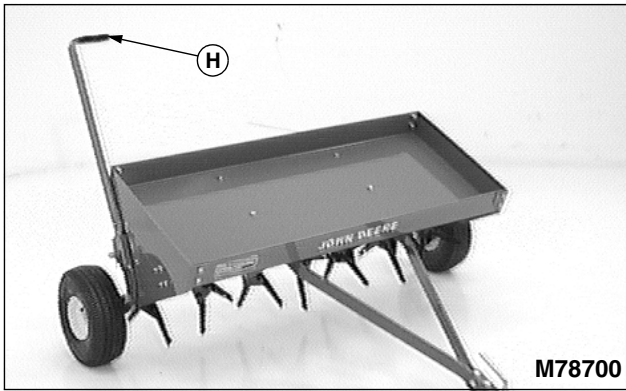

5. Install vinyl handle grip (H) on lift handle.

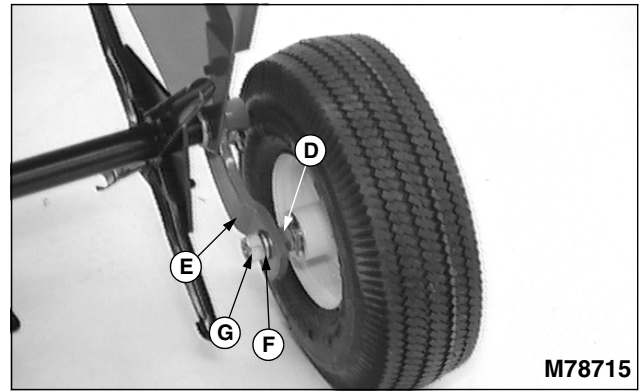

5. Install wheel assembly on lift arm (E). Then install 1/2 in. lockwasher (F) and 1/2 in. hex nut (G). Hold wrench on nut (D) and tighten nut (G) completely. This will ensure the wheel hub remains properly adjusted.
6. Repeat for other wheel assembly.

Assemble Transport Wheels

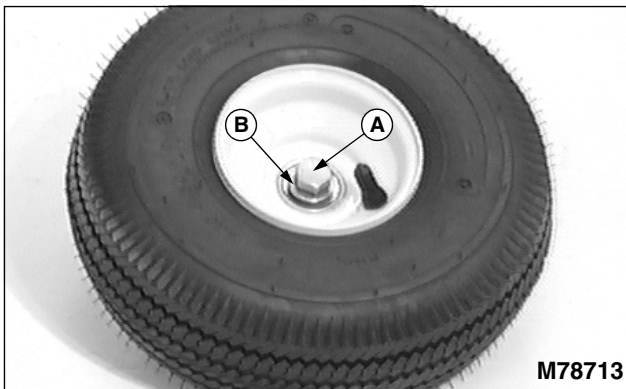

1. Install 1/2 x 3 3/4 in. hex bolt (A) and 17/32 x 1/16 x 3/32 in. flat washer (B) on valve stem side of wheel hub.

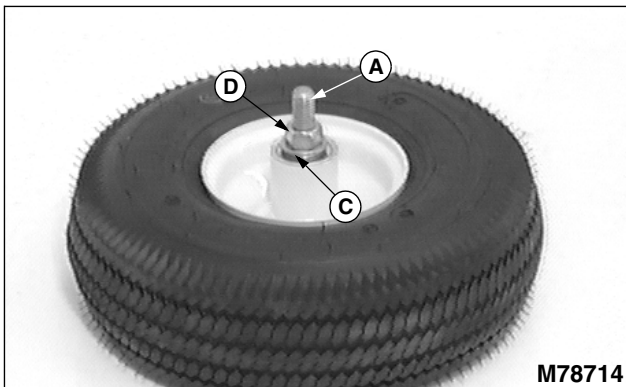

2. Turn wheel over and install 17/32 x 1/16 x 3/32 in. flat washer (C) and 1/2 in. hex nut (D).
3. Tighten nut (D) until washers (B) and (C) keep bearing from turning on bolt without forcing bearings to be pressed inward. After tightening, make sure the wheel can be turned by hand with the bearing remaining stationary on the bolt.
4. Repeat for other wheel assembly.

ASSEMBLY - SPIKER AERATOR

Identify Parts

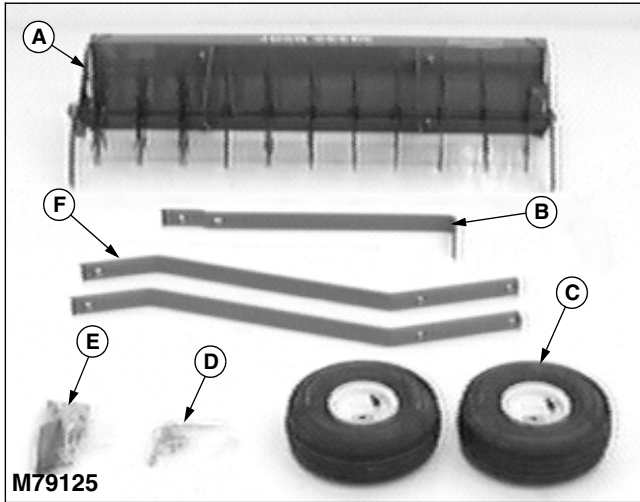

Qty.	Part Description
4	Flat Washer, 1/2 in.
1	Hex Bolt, 5/16 x 1-1/2 in.
7	Nylock Nut, 5/16 in.
5	Flat Washer, 5/16 in.
1	Special Plow Bolt, 3/8 x 2 in.
1	Flat Washer, 3/8 in.
1	Oblong Locknut, 3/8 in.

Box of Parts

Qty.	Part Description
1	Tine Tray Assembly (A)
1	Lift Handle (B)
2	Wheel Assembly (C)
1	Hitch Pin Assembly (D)
1	Bag of Parts (E)
2	Tow Bar (F)

Assemble Tow Bars

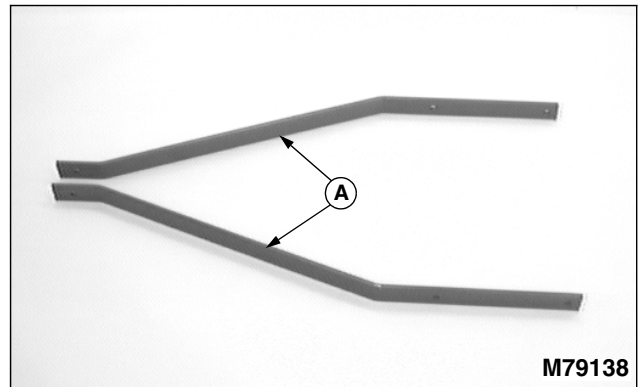

1. Align tow bars (A) as shown.

Bag of Parts

Qty.	Part Description
1	Vinyl Handle Grip
2	Painted Clevis
2	Transport Lock Pin
2	Hex Nut, 5/16 in.
2	Lockwasher, 5/16 in.
1	Spring
4	Hex Bolt, 5/16 x 1 in.
2	Carriage Bolt, 5/16 x 2-1/4 in.
2	Hex Bolt, 1/2 x 3-3/4 in.
4	Hex Nut, 1/2 in.
2	Lockwasher, 1/2 in.

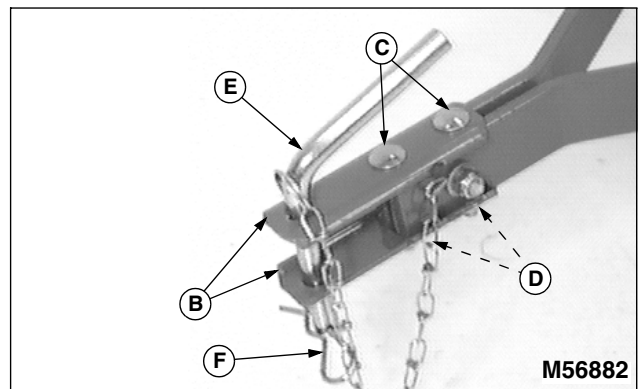

2. Assemble two clevis straps (B) to front of tow bars using two 5/16 x 2-1/4 in. carriage bolts (C) and two locknuts (D). Hand tighten only.
3. Slide clevis assembly forward until front carriage bolt is within 6 mm (1/4 in.) from the end of tow bars.
4. Install hitch pin (E) in clevis and fasten with spring locking pin (F) through chain loop.

ASSEMBLY - SPIKER AERATOR

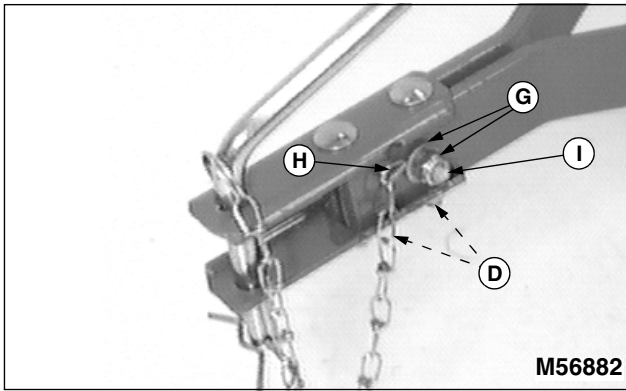

M56882

5. Install 5/16 x 1-1/2 in. cross hex bolt (I). Place chain hook (H) around bolt and secure with 5/16 in. flat washer and locknut (I).
6. Align tow bars and clevis. Tighten nuts (D) completely.
7. Tighten nylock nut (G) while holding chain hook forward and centered between clevis halves.

Install Tow Bars to Tray Assembly



CAUTION: Avoid injury! Tines have extremely sharp points. Wear gloves and handle with care.

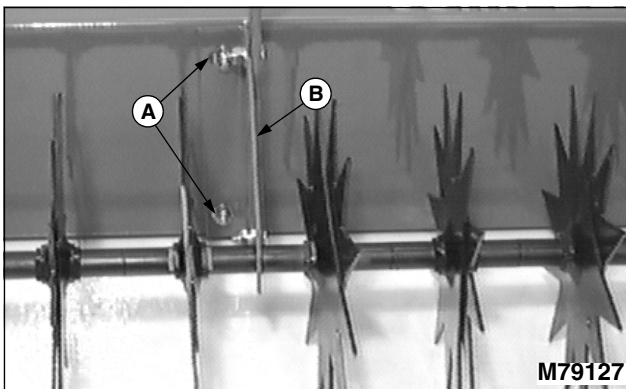

M79127

1. Stand tray assembly on its back. Loosen nylock nuts (A) on mounting brackets (B) to ensure proper bracket alignment while installing tow bars.

NOTE: You may want to have a helper or use a hoist to steady tow bars during alignment.

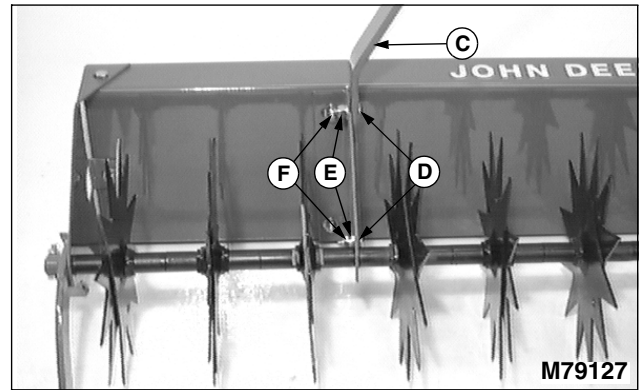

M79127

2. Align tow bars (C) to insides of brackets (B) and fasten with two 5/16 x 1 in. hex bolts (D), flat washer (E), and nylock nuts (F). Hand tighten only. Repeat for other side.
3. Hold tow bars all the way to top of slots and tighten nylock nuts (F).
4. Tighten nylock nuts (A) on mounting brackets.

Assemble Transport Wheels

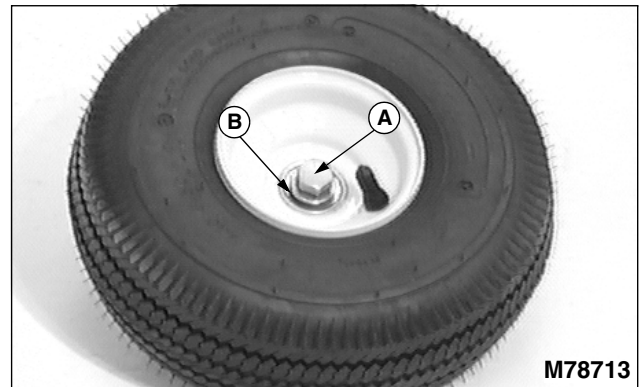

M78713

1. Install 1/2 x 3-3/4 in. hex bolt (A) and 1/2 in. flat washer (B) on valve stem side of wheel hub.

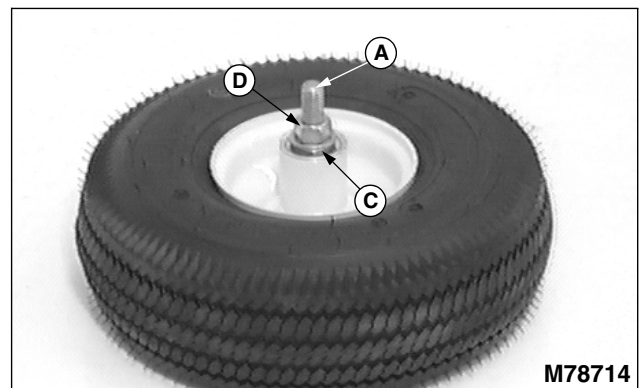

M78714

2. Turn wheel over to install second 1/2 in. flat washer (C)

ASSEMBLY - SPIKER AERATOR

and 1/2 in. hex nut (D).

3. Tighten nut (D) until washers (B) and (C) keep bearing from turning on bolt without forcing bearings to be pressed inward. This causes wheel hub to rotate on bearings.

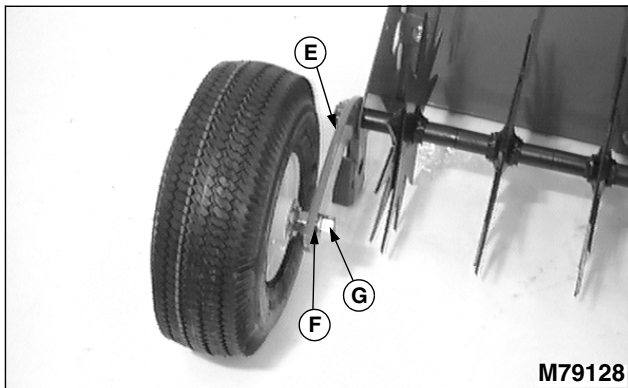

4. Install wheel assembly on lift arm (E), one on each side, and secure with 1/2 in. lockwasher (F) and 1/2 in. hex nut (G). Tighten nut securely so wheel hubs are free to turn on bearings.

Install Lift Lever



CAUTION: Avoid injury! Tines have extremely sharp points. Wear gloves and handle with care.

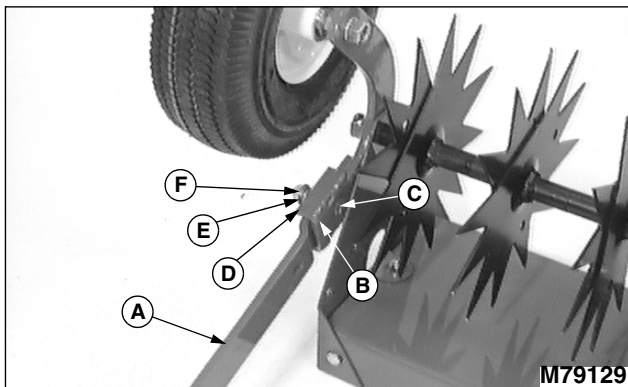

1. Turn tray on its top and align lift lever (A), with offset to outside, to right side of lift arm (B).

2. Fasten with 3/8 x 2 in. flat-top beveled carriage bolt (C), head of bolt to the inside, and on outside spring (D), 3/8 in. flat washer (E), and 3/8 in. oblong locknut (F).

NOTE: Be sure head of carriage bolt (C) is properly seated in square hole of wheel assembly bracket during tightening of locknut.

3. Tighten locknut (F) until one full thread is exposed.

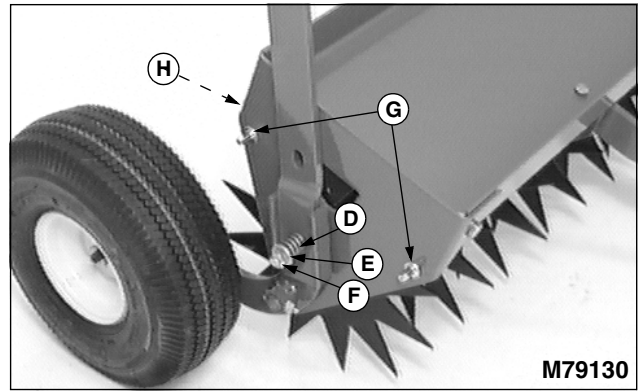

4. Turn tray upright and install two 5/16 in. transport lock pins (G), extending pin to the outside, and fasten with 5/16 in. lockwashers, and 5/16 in. hex nuts (H) to the inside. Tighten nuts.

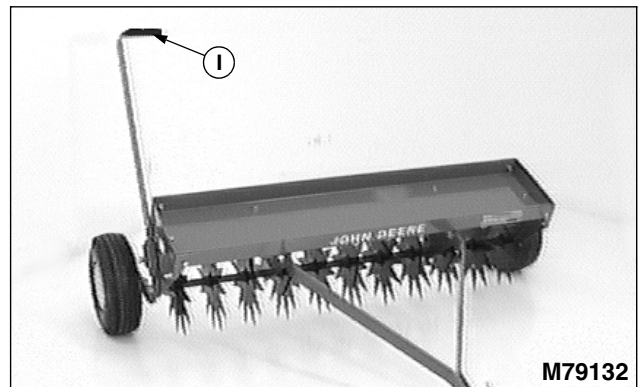

5. Install hand grip (I) on lift lever.

ASSEMBLY - AERATOR-SPREADER

Identify Parts

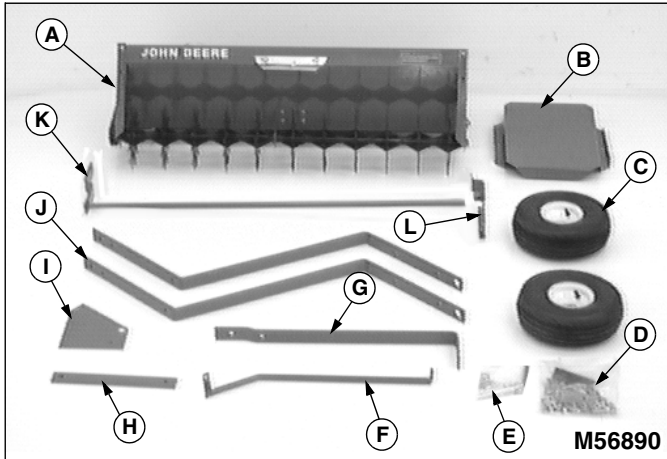

Box of Parts

Qty.	Part Description
1	Hopper Assembly (A)
1	Weight Tray (B)
2	Wheel Assembly (C)
1	Bag of Parts (D)
1	Tethered Pin Assembly (E)
1	Flow Control Lever (F)
1	Lift Handle (G)
1	Tow Bar Support Strap (H)
1	Lift Plate (I)
2	Tow Bar (J)
1	Lift Shaft Assembly (K)
1	Wheel/Lift Lever Mounting Bracket (L)

Bag of Parts

Qty.	Part Description
1	Shutter Link
4	Transport Lock Pin
1	Vinyl Handle Grip
2	Clevis
1	Spring
4	Hex Bolt, 5/16 x 1-1/2 in.

Qty.	Part Description
2	Carriage Bolt, 5/16 x 2-1/4 in.
1	Special Plow Bolt, 3/8 x 2 in.
3	Hex Head Bolt, 5/16 x 3/4 in.
1	Hex Bolt, 5/16 x 1-1/4 in.
2	Hex Bolt, 1/2 x 3-3/4 in.
4	Hex Nut, 5/16 in.
4	Hex Nut, 1/2 in.
4	Lockwasher, 5/16 in.
2	Lockwasher, 1/2 in.
1	Flat Washer, 5/16 in.
1	Flat Washer, 3/8 in.
4	Flat Washer, 1/2 in.
1	Locknut, 3/8 in.
10	Nylock Nut, 5/16 in.

Assemble Transport Wheels

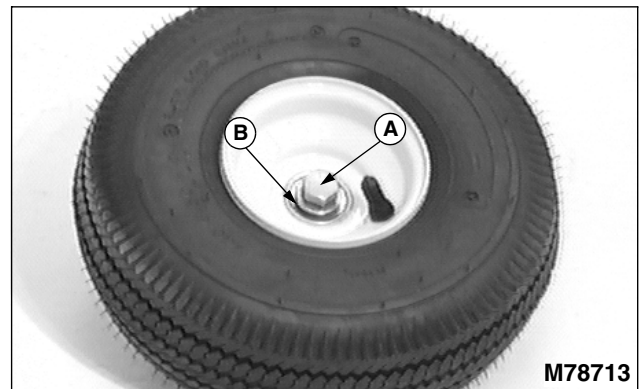

1. Install 1/2 x 3-3/4 in. hex bolt (A) and 1/2 in. flat washer (B) on valve stem side of wheel hub.

ASSEMBLY - AERATOR-SPREADER

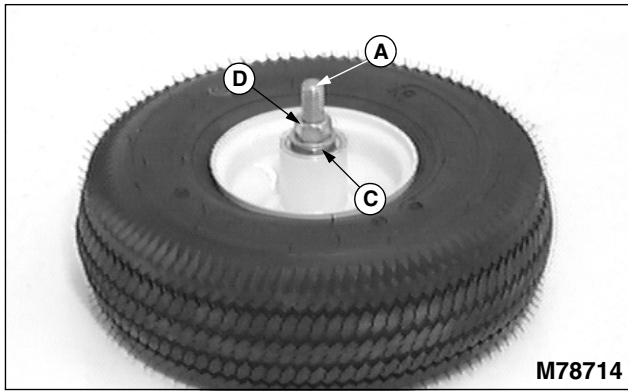

2. Turn wheel over to install second 1/2 in. flat washer (C) and 1/2 in. hex nut (D).
3. Tighten nut (D) until washers (B) and (C) keep bearing from turning on bolt without forcing bearings to be pressed inward. This causes wheel hub to rotate on bearings.

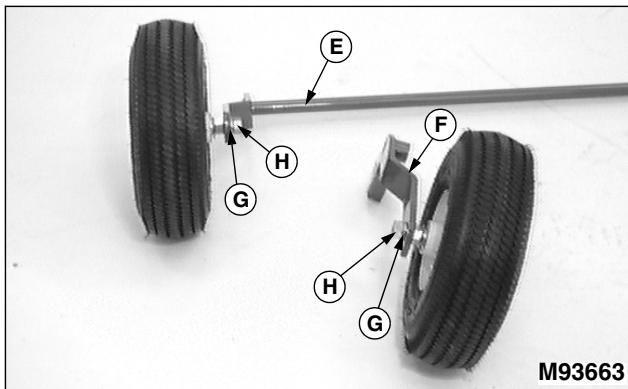

4. Install wheel assemblies to support brackets (E) and (F) and fasten with 1/2 in. lockwasher (G) and 1/2 in. hex nut (H).
5. Tighten nut securely so wheel hubs are free to turn on bearings.
6. Set wheel assemblies aside.

Assemble Tow Bars

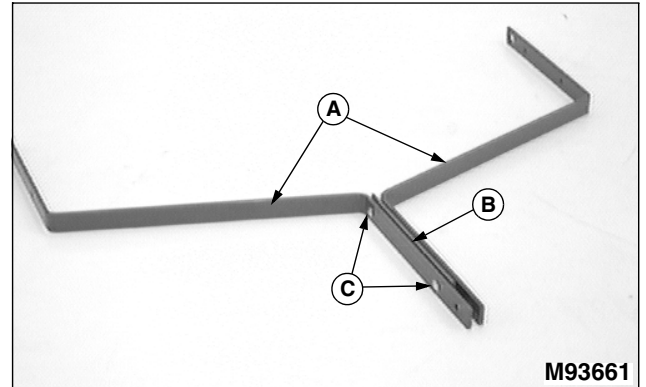

1. Align tow bars (A) as shown.
2. Align support strap (B) between tow bars and fasten with two 5/16 x 1-1/2 in. hex bolts and nylock nuts (C). Hand tighten only.

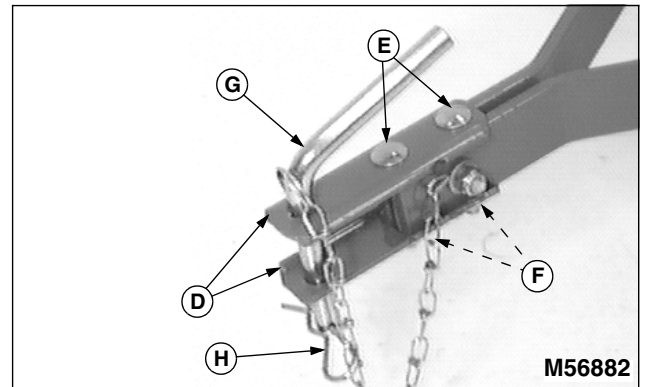

3. Assemble two clevis straps (D) to front of tow bars using two 5/16 x 2-1/4 in. carriage bolts (E) and two locknuts (F). Hand tighten only.
4. Slide clevis assembly forward until front carriage bolt is within 6 mm (1/4 in.) from the end of tow bars.
5. Install hitch pin (G) in clevis and fasten with spring locking pin (H) through chain loop.

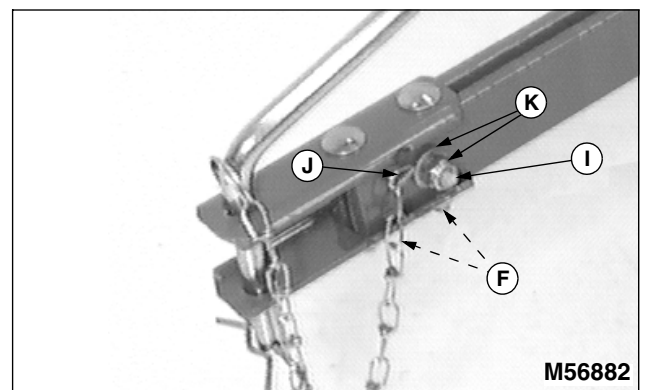

6. Install 5/16 x 1-1/2 in. cross hex bolt (I). Place chain hook (J) around bolt and secure with 5/16 in. flat washer (K).

ASSEMBLY - AERATOR-SPREADER

and locknut (K).

- Align tow bars and clevis. Tighten nuts (F) completely.
- Tighten nylock nut (K) while holding chain hook forward and centered between clevis halves.

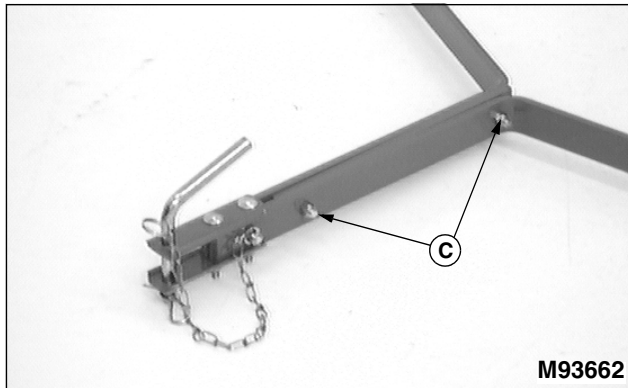

- Tighten tow bar nylock nuts (C).

Install Tow Bars, Wheel Assembly, and Lift Lever to Hopper

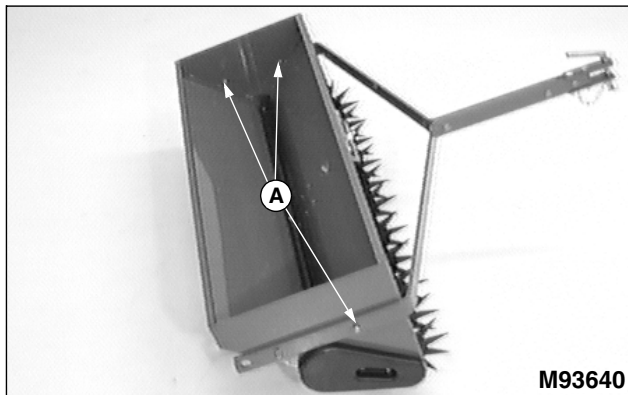

- Align four tow bar holes with four hopper side holes.
- Fasten tow bar to hopper with three 5/16 x 3/4 in. hex bolts, bolt heads to the inside, and nylock nuts (A). Hand tighten only.

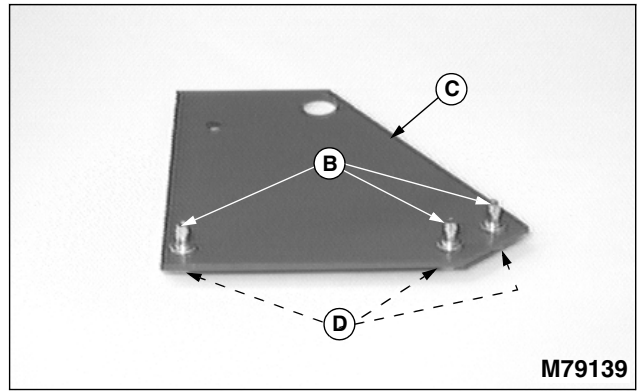

- Install three transport lock pins (B) into lift plate (C) as shown and fasten with three 5/16 in. lockwashers and hex nuts (D).

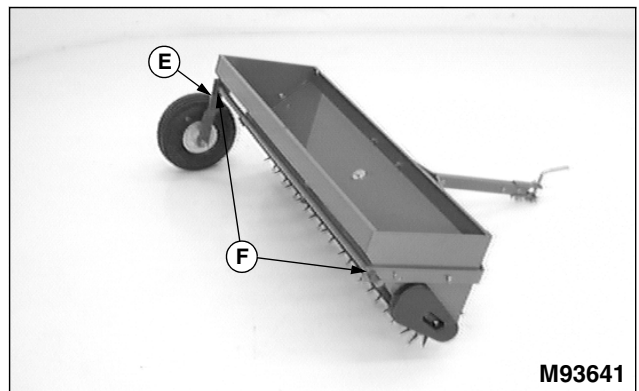

- Install left wheel assembly (E) with long shaft through large holes (F) of tow bar.
- Install lift plate assembly (C) onto end of long shaft.

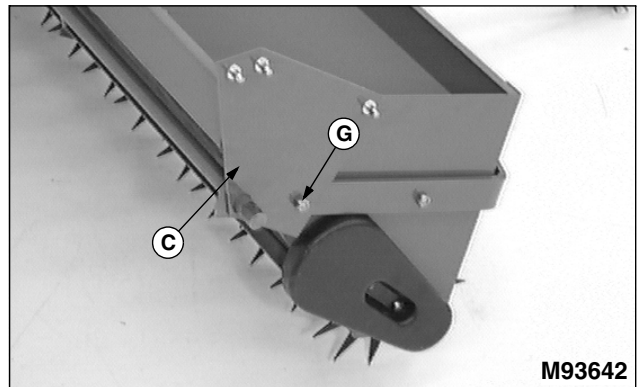

- Align small hole of lift plate with tow bar and hopper small holes.
- Fasten with 5/16 x 1-1/4 in. hex bolt and nylock nut (G).
- Hold tow bar so top edge of tow bar is parallel with top edge of hopper.
- Tighten three nylock nuts (A) and last installed nylock nut (G).

ASSEMBLY - AERATOR-SPREADER

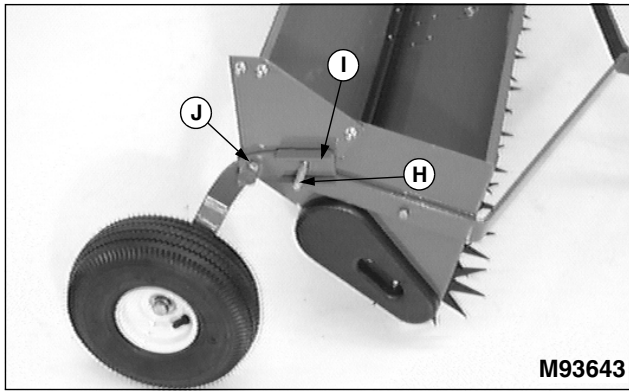

10. Install 3/8 x 2 in. special bolt (H), head of bolt to the inside, into right wheel assembly bracket (I).

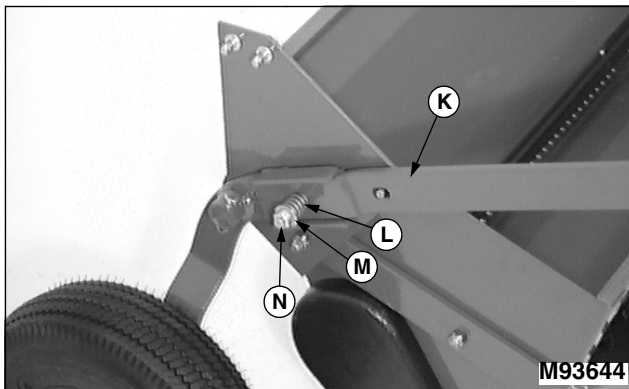

11. Install right wheel assembly (I) on to end of long shaft and fasten with 5/16 x 1-1/2 in. hex bolt and nylock nut (J).

12. Install lift lever (K), with offset to the outside, onto special bolt (H) and fasten with spring (L), 3/8 in. flat washer (M), and 3/8 in. locknut (N).

NOTE: Be sure head of special bolt (H) is properly seated in square hole of wheel assembly bracket during tightening of locknut.

13. Tighten locknut (N) until one full thread is exposed.

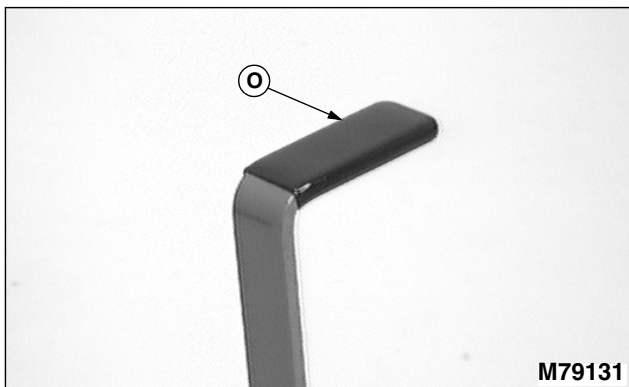

14. Slide vinyl handle grip (O) over end of lift lever.

Install Hopper Flow Control Lever



CAUTION: Avoid injury! Aerator Tines are extremely sharp. Wear gloves and handle with care.

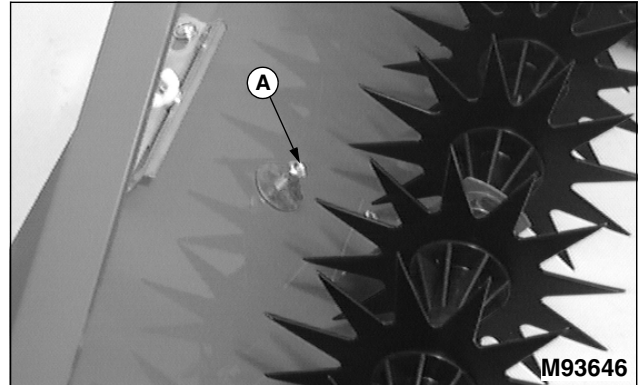

1. Stand hopper assembly on its back.
2. Remove 5/16 x 1-1/2 in. hex bolt, two large flat washers, and locknut (A) from hopper.

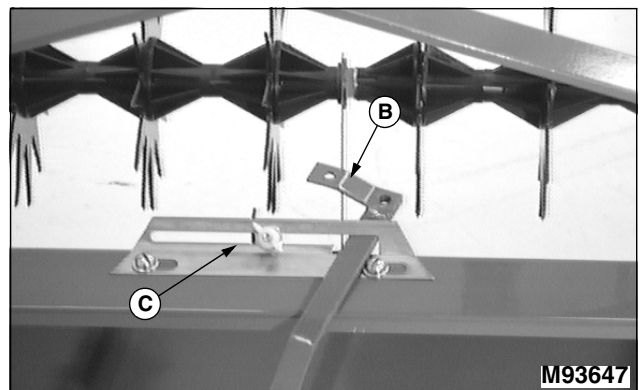

3. Install "L"-shaped end (B) of flow control lever into slot of calibration plate (C).

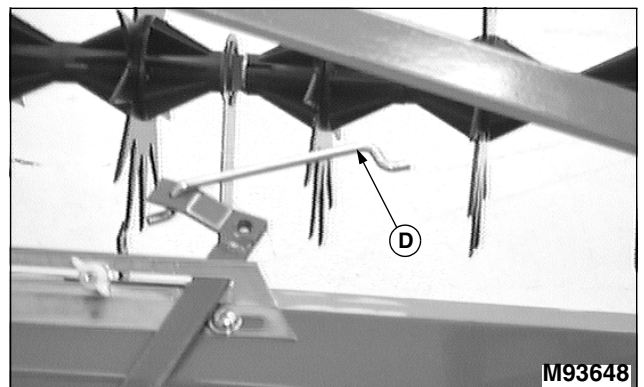

4. Install one end of shutter link (D) into end of flow control lever.

ASSEMBLY - AERATOR-SPREADER

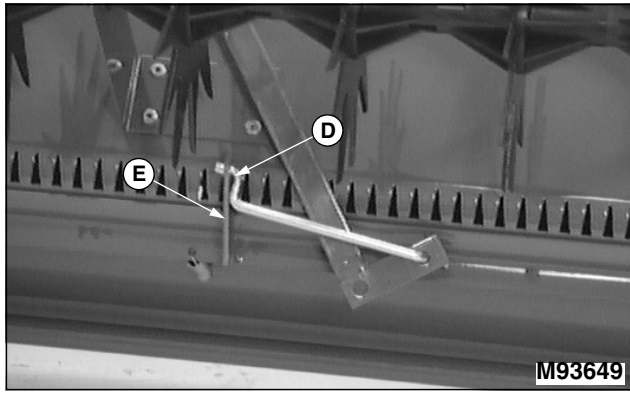

5. Slide lever down between hopper and spike assembly and install other end of shutter link (D) into shutter arm (E).

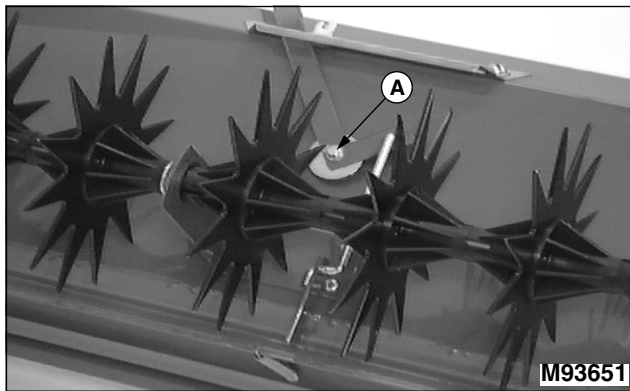

6. Slide lever up to align pivot hole with hopper hole and fasten with 5/16 x 1-1/2 in. hex bolt and large washer, (inside-out), and second large washer and locknut (A), (from the outside).

7. Tighten locknut until lever has sufficient drag to hold its position when released.

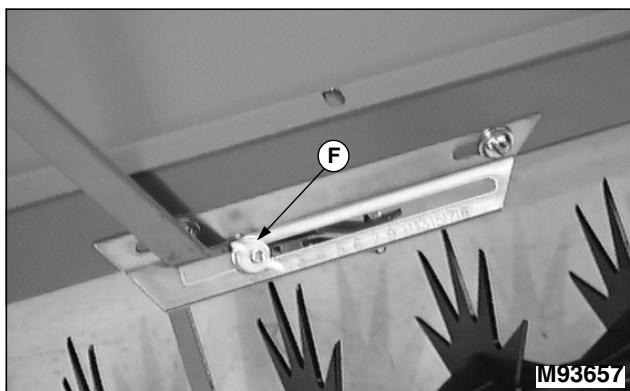

8. Return hopper assembly to the upright position.

9. Move lever into closed position and lock it with wing nut lock assembly (F).

Install Weight Tray

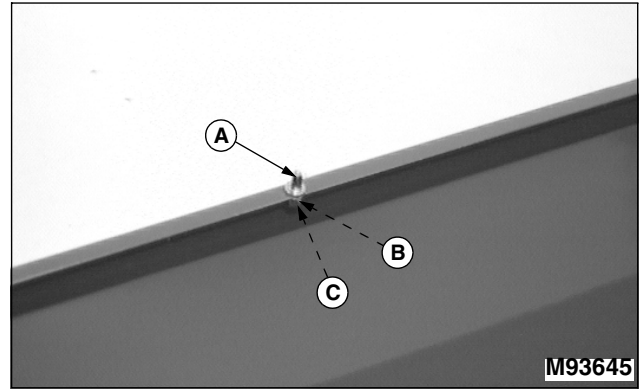

1. Install last transport lock pin (A) into center hole of rear hopper lip and fasten with 5/16 in. lockwasher (B) and hex nut (C).

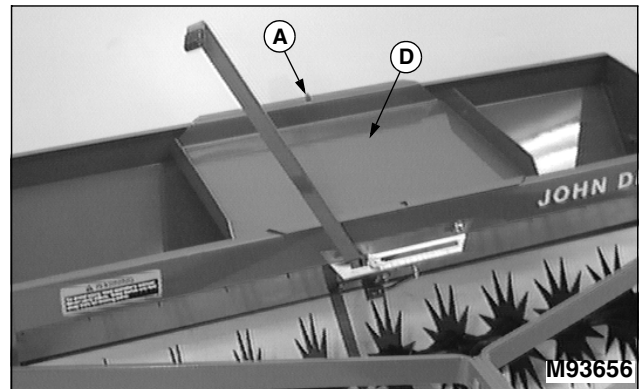

2. Install weight tray (D) over pin (A) and hopper lips as shown.

ASSEMBLY - LAWN ROLLER

Identify Box of Parts

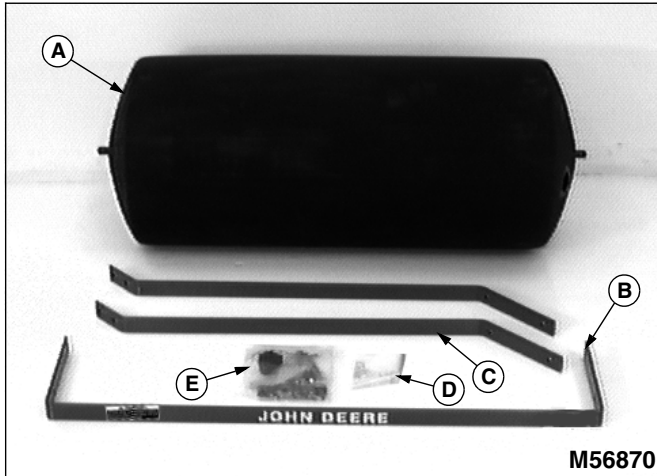

Box of Parts

Qty.	Part Description
1	Roller Drum (A)
1	Scraper Bar Frame (B)
2	Bar Frame (C)
1	Tethered Pin Assembly (D)
1	Bag of Parts (E)

Bag of Parts

Qty.	Part Description
2	Painted Clevis
1	Plastic Plug
4	Hex Bolt, 5/16 x 1 in.
2	Hex Bolt, 5/16 x 1-1/2 in.
2	Carriage Bolt, 5/16 x 2-1/4 in.
2	Flat Washer, 5/16 in.
4	Flat Washer, 5/8 in.
8	Nylock Nut, 5/16 in.
2	Nylon Bearing, 5/8 in.
2	Snap Ring, 5/8 in.
1	Frame Spacer

Install Scraper Frame Bar

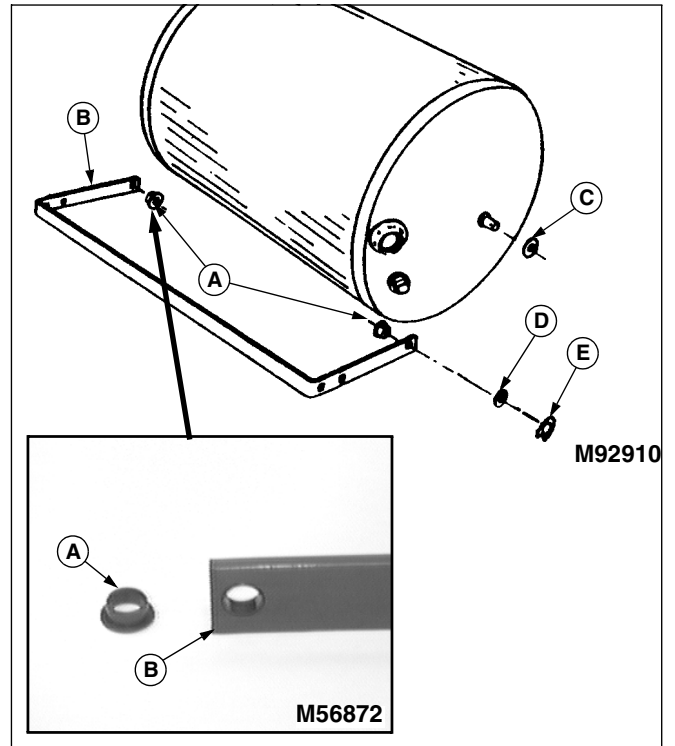

1. Insert a 5/8 in. nylon bearing (A), from inside out, into round hole at each end of scraper frame bar (B).

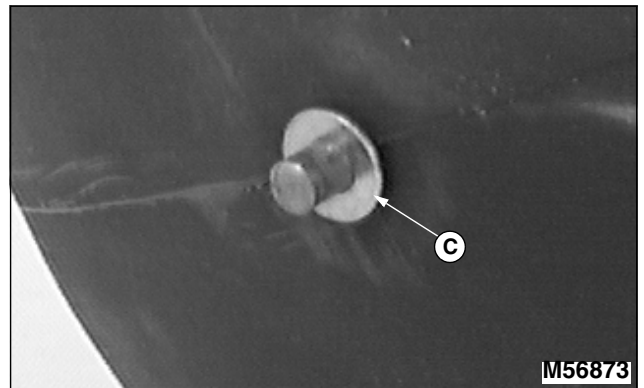

2. Remove the vinyl caps that are over ends of roller assembly axle and slide a 5/8 in. flat washer (C) onto each end.

ASSEMBLY - LAWN ROLLER

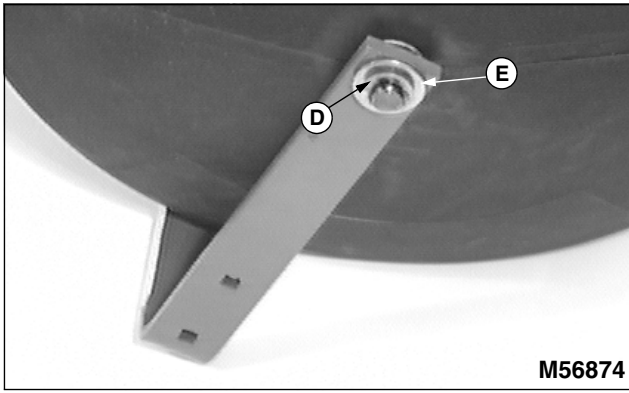

3. Slide one end of the scraper frame bar on one end of roller assembly and then spring the other end of scraper frame bar open and slide it over the opposite end of roller axle as shown.

4. Install another 5/8 in. flat washer (D) over each end of axle and secure with a 5/8 in. snap ring (E).

Install Frame Extension Bars

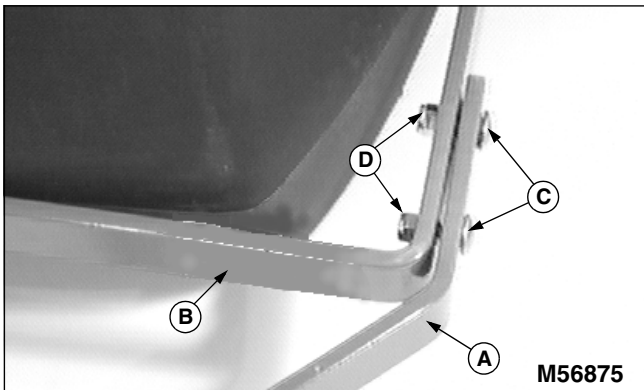

1. Attach short end of each frame extension bar (A) to scraper frame bar (B) and fasten with two 5/16 x 1 in. hex bolts (C) and two 5/16-18 in. nylock nuts (D) on each side. Frame extension bars will meet at center. Hand tighten only.

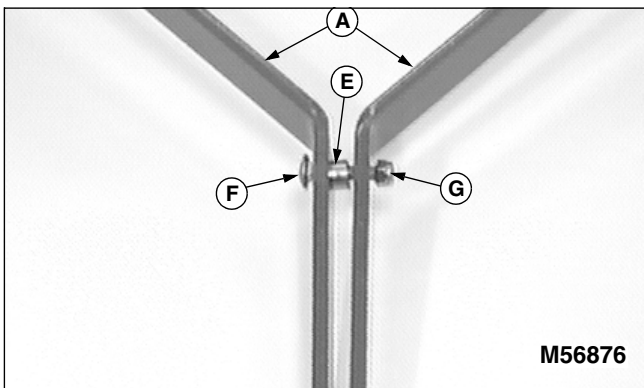

2. Position spacer (E) between frame extension bars (A),

using rear set of holes, and secure with a 5/16 x 1-1/2 in. hex bolt (F) and 5/16 in. nylock nut (G). Hand tighten only.

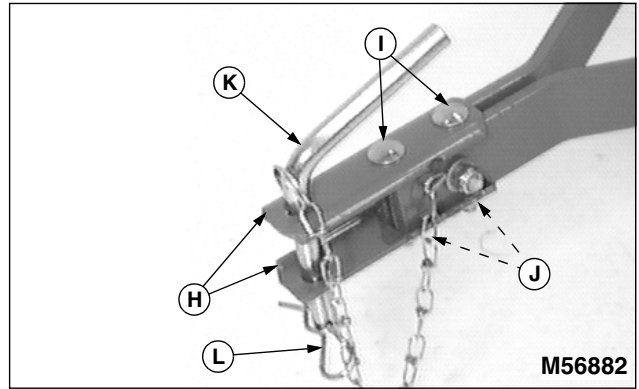

3. Assemble two clevis straps (H) to front of tow bars using two 5/16 x 2-1/4 in. carriage bolts (I) and two locknuts (J). Hand tighten only.

4. Slide clevis assembly forward until front carriage bolt is within 6 mm (1/4 in.) from the end of tow bars.

5. Install hitch pin (K) in clevis and fasten with spring locking pin (L) through chain loop.

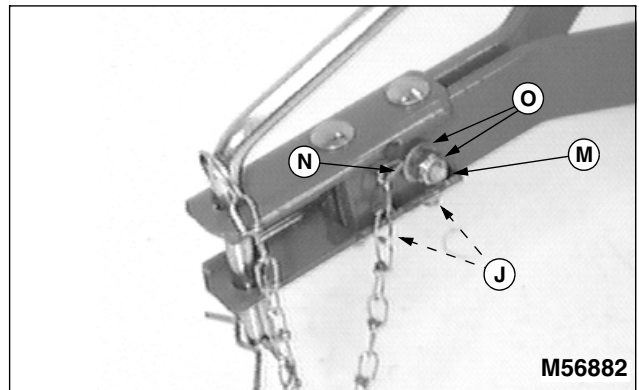

6. Install 5/16 x 1-1/2 in. cross hex bolt (M). Place chain hook (N) around bolt and secure with 5/16 in. flat washer and locknut (O).

7. Align tow bars and clevis. Tighten nuts (J) completely.

8. Tighten nylock nut (M) while holding chain hook forward and centered between clevis halves.

9. Tighten all bolts completely.

SPECIFICATIONS

Thatcherator

Width	101.6 cm (40 in.)
Number of Tines	20, spring-loaded
Weight Tray Capacity	45 kg (100 lb)

Plug Aerator

Width

40 in. Model	102 cm (40 in.)
48 in. Model	122 cm (48 in.)

Tine Penetration	Up to 76 mm (3 in.)
------------------------	---------------------

Number of Tines

40 in. Model	28
48 in. Model	48

Tine Spacing

40 in. Model	15.2 cm (6 in.)
48 in. Model	10.2 cm (4 in.)

Weight Tray Capacity

40 in. Model	79.4 kg (175 lb)
48 in. Model	113.4 kg (250 lb)

Tires

Size	4.10 x 3.50-4
Maximum Air Pressure	206 kPa (30 psi)

Spiker Aerator

Width	102 cm (40 in.)
-------------	-----------------

Tine Penetration	Up to 51 mm (2 in.)
------------------------	---------------------

Number of Tines	132
-----------------------	-----

Tine Spacing	89 mm (3.5 in.)
--------------------	-----------------

Weight Tray Capacity	45 kg (100 lb)
----------------------------	----------------

Tires

Size	4.10 x 3.50-4
Maximum Air Pressure	206 kPa (30 psi)

Aerator-Spreader

Width	101.6 cm (40 in.)
-------------	-------------------

SPECIFICATIONS

Tine Penetration	Up to 51 mm (2 in.)
Number of Tines	132
Tine Spacing	89 mm (3.5 in.)
Hopper Capacity	34 kg (75 lb)
Weight Tray Capacity	34 kg (75 lb)

Tires

Size	4.10 x 3.50-4
Maximum Air Pressure	206 kPa (30 psi)

Lawn Roller

Width	91 cm (36 in.)
Fill Capacity	159 L (42 gal)
Weight (filled)	176 kg (390 lb)

INDEX

A

- Aerator-Spreader Flow Control, Using 13
- Aerator-Spreader Operating Positions, Selecting 13
- Aerator-Spreader, Operating 16
- Aerator-Spreader, When to Use the 13

F

- Flow Control Setting (Alternative Method), Determining 14
- Flow Control Setting, Determining 14
- Flow Control, Using the Aerator-Spreader 13
- Frame Extension Bars, Install (Lawn Roller) 36

H

- Hopper Flow Control Lever, Install (Aerator/Spreader) .. 33
- Hopper and Weight Tray, Using the Aerator-Spreader .. 14

I

- Installing Tow-Behind Attachment 4

L

- Lawn Roller, Operating Safely 17
- Lawn Roller, Operating the 17
- Lift Handle, Using Aerator-Spreader 13
- Lift Handle, Using Plug Aerator 9
- Lift Handle, Using Spiker Aerator 11
- Lift Handle, Using Thatcherator 6
- Lift Lever, Install (Plug Aerator) 25
- Lift Lever, Install (Spiker Aerator) 29

M

- Maintenance, Practice Safe 2
- Mounting Brackets, Tow Bars, and Lift Lock Plate, Install (Thatcherator) 21

O

- Operating Safety 1

P

- Parking Safely 2
- Parts for Assembly (Aerator/Spreader) 30
- Parts for Assembly (Lawn Roller) 35
- Parts for Assembly (Plug Aerator) 24
- Parts for Assembly (Spiker Aerator) 27
- Parts for Assembly (Thatcherator) 20
- Plug Aerator Operating Positions, Selecting 9
- Plug Aerator, Operating 10
- Plug Aerator, Parts for Assembly 24
- Plug Aerator, When to Use the 9
- Plugging Spoon Operation, Checking the 9

R

- Rate of Flow (Alternative Method), Determining 14
- Rate of Flow, Determining 14
- Removing Tow-Behind Attachment 5
- Roller, Operating the Lawn 17

S

- Safety, Operating 1
- Safety, Tire 3
- Scraper Frame Bar, Install (Lawn Roller) 35
- Service Safety 2
- Servicing the Attachment 18
- Speed, Checking Tractor Ground 7, 10, 12, 16, 17
- Spiker Aerator Operating Positions, Selecting 11
- Spiker Aerator, Operating 12
- Spiker Aerator, When to Use the 11
- Storing the Attachment 19

T

- Thatcherator Assembly 22
- Thatcherator Operating Positions, Selecting 6
- Thatcherator Tine Action 6
- Thatcherator Tines, Replacing 18
- Thatcherator, Operating 7
- Thatcherator, Parts for Assembly 20
- Thatcherator, When to Use the 6
- Tine Action, Adjusting for Proper Thatcherator 7
- Tine Action, Thatcherator 6
- Tine Operation, Checking the Spiker Aerator 12
- Tine and Spreader Operation, Checking the Aerator-Spreader 14
- Tines, Replacing Thatcherator 18
- Tow Bars to Plug Tray Assembly 25
- Tow Bars to Tine Tray (Spiker Aerator) 28
- Tow Bars, Assemble (Aerator/Spreader) 31
- Tow Bars, Wheel Assembly, and Lift Lever to Hopper, Install (Aerator/Spreader) 32

W

- Weight Tray and Hopper, Using the Aerator-Spreader ... 14
- Weight Tray, Install (Aerator/Spreader) 34
- Weight Tray, Using the Plug Aerator 9
- Weight Tray, Using the Spiker Aerator 11
- Weight Tray, Using the Thatcherator 6
- Wheels, Assemble (Aerator/Spreader) 30
- Wheels, Assemble (Plug Aerator) 26
- Wheels, Assemble (Spiker Aerator) 28
- Wheels, Installing on Thatcherator 22

JOHN DEERE QUALITY STATEMENT

John Deere Quality



John Deere equipment is more than just a purchase, it's an investment in quality. That quality goes beyond our equipment to your John Deere dealer's parts and service support. This support is needed to keep you a satisfied customer.

That's why John Deere has initiated a process to handle your questions or problems, should they arise. The following three steps will help guide you through the process.

Step 1

Refer to your operator's manual

- A. It has many illustrations and detailed information on the safe and proper operation of your equipment.
- B. It gives troubleshooting procedures, and specification information.
- C. It gives ordering information for parts catalogs, service and technical manuals.
- D. If your questions are not answered in the operator's manual, then go to Step 2.

Step 2

Contact your dealer

- A. Your John Deere dealer has the responsibility, authority, and ability to answer questions, resolve problems, and fulfill your parts and service needs.
- B. First, discuss your questions or problems with your dealer's trained parts and service staff.
- C. If the parts and service people are unable to resolve your problem, see the dealership manager or owner.
- D. If your questions or problems are not resolved by the dealer, then go to Step 3.

Step 3

Call the John Deere Customer Communications Center

- A. Your John Deere dealer is the most efficient source in addressing any concern, but if you are not able to resolve your problem after checking your operator's manual and contacting your dealer, call the Customer Communications Center.
- B. For prompt, effective service, please have the following ready before you call:
 - The name of the dealer with whom you've been working.
 - Your equipment model number.
 - Number of hours on machine (if applicable).
 - Your 13-digit serial number which you recorded on the inside front cover of this manual.
 - If the problem is with an attachment, your attachment identification number.
- C. Then call 1-800-537-8233 and our advisor will work with your dealer to investigate your concern.