



1.5HP 115V IN/ABOVE GROUND POOL PUMP 5280GPH

ITEM #75038



OWNER'S MANUAL AND SAFETY INSTRUCTIONS

SAVE THIS MANUAL: KEEP THIS MANUAL FOR SAFETY WARNINGS, PRECAUTIONS, ASSEMBLY, OPERATING, INSPECTION, MAINTENANCE AND CLEANING PROCEDURES. WRITE THE PRODUCT'S SERIAL NUMBER ON THE BACK OF THE MANUAL NEAR THE ASSEMBLY DIAGRAM (OR MONTH AND YEAR OF PURCHASE IF PRODUCT HAS NO NUMBER).

FOR QUESTIONS PLEASE CALL OUR CUSTOMER SUPPORT: (909) 628 0880 MON-FRI 9AM TO 3PM PST

IMPORTANT SAFETY INFORMATION



GENERAL SAFETY WARNINGS

Read all safety warnings and instructions. Failure to follow the warnings and instructions may result in electric shock, fire and/or serious injury. Save all warnings and instructions for future reference.

SAFETY

The warnings, precautions, and instructions discussed in this instruction manual cannot cover all possible conditions and situations that may occur. It must be understood by the operator that common sense and caution are factors which cannot be built into this product, but must be supplied by the operator. Read carefully and understand all ASSEMBLY AND OPERATION INSTRUCTIONS before operating. Failure to follow the safety rules and other basic safety precautions may result in serious personal injury.

- **Read and understand all instructions.** Failure to follow all instructions may result in serious injury or property damage.
- **DO NOT** allow persons to operate or assemble the product until they have read this manual and have developed a thorough understanding of how it works.
- **DO NOT modify this product in any way.** Unauthorized modification may impair the function and/or safety and could affect the life of the product. There are specific applications for which the product was designed.
- **Use the right tool for the job. DO NOT** attempt to force small equipment to do the work of larger industrial equipment. There are certain applications for which this equipment was designed. This product will be safer and do a better job at the capacity for which it was intended. **DO NOT** use this equipment for a purpose for which it was not intended.
- Industrial or commercial applications must follow OSHA requirements.
- **Keep children and bystanders away from the work area while operating the tool. DO NOT** allow children to handle the product.
- This pump is intended for use on permanently installed swimming pools and may also be used with hot tubs and spas if so marked. **DO NOT** use with storable pools. A permanently installed pool is constructed in or on the ground or in a building such that it cannot be readily disassembled for storage. A storable pool is constructed so that it is capable of being readily disassembled for storage and reassembled to its original integrity.
- Though this product is designed for outdoor use, it is strongly advised to protect the electrical components from the weather. Select a well-drained area, one that will not flood when it rains. It requires free circulation of air for cooling. **DO NOT install in a damp or non-ventilated location.**
- Pool and spa components have a finite life. All components should be inspected frequently and replaced at least every five years, or if found to be damaged, broken, cracked, missing, or not securely attached.
- **Hazardous voltage can shock, burn, or cause death.** To reduce the risk of electric shock, **DO NOT** use an extension cord to connect unit to electric supply. Provide a properly located outlet. It is required that licensed electricians do all electrical wiring. All electrical wiring **MUST** be in conformance with applicable local and national codes and regulations. Before working on pump or motor, disconnect motor wiring.

- To reduce the risk of electric shock replace damaged cord immediately. **DO NOT** bury cord. Locate cord to prevent abuse from lawn mowers, hedge trimmers and other equipment.
- Risk of Electric Shock. Connect only to a branch circuit protected by a ground-fault circuit-interrupter (GFCI). Contact only to a electrician if you cannot verify that the receptacles is protected by a GFCI.
- Failure to bond pump to pool structure will increase risk for electrocution and could result in injury or death. To reduce the risk of electric shock, see installation instructions and consult a professional electrician on how to bond pump. Also, contact a licensed electrician for information on local electrical codes for bonding requirements.
- Use a solid copper conductor, size 8 or larger. Run a continuous wire from external bonding lug to reinforcing rod or mesh. Connect a No. 8 AWG (8.4 mm²) solid copper bonding wire to the pressure wire connector provided on the motor housing and to all metal parts of swimming pool, spa, or hot tub, and to all electrical equipment, metal piping (except gas piping), and conduit within 5 ft. (1.5m) of inside walls of swimming pool, spa, or hot tub.

IMPORTANT - Reference NEC codes for all wiring standards including, but not limited to, grounding, bonding and other general wiring procedures.

NOTE - The National Electrical Code (NEC) permits use of a cord with a maximum 3 ft. (1 m) length. If your pump is equipped with a cord complying with the NEC

- **DO NOT** install within an outer enclosure or beneath the skirt of a hot tub or spa.
- **Suction Entrapment Hazard: Suction in suction outlets and/or suction outlet covers, which are damaged, broken, cracked, missing or unsecured cause severe injury and/or death due to the following entrapment hazards:**
 - Hair Entrapment-** Hair can become entangled in suction outlet cover.
 - Limb Entrapment-** A limb inserted into an opening of a suction outlet sump or suction outlet cover that is damaged, broken, cracked, missing, or not securely attached can result in a mechanical bind or swelling of the limb.
 - Body Suction Entrapment-** A pressure applied to a large portion of the body or limbs can result in an entrapment.
 - Evisceration/ Disembowelment-** A negative pressure applied directly to the intestines through an unprotected suction outlet sump or suction outlet cover which is damaged, broken, cracked, missing, or unsecured can result in evisceration/disembowelment.
 - Mechanical Entrapment-** There is potential for jewelry, swimsuits, hair decorations, fingers, toes, or knuckles to be caught in an opening of a suction outlet cover resulting in mechanical entrapment.
- **To Reduce the risk of Entrapment Hazards: When outlets are small enough to be blocked by a person, a minimum of two functioning suction outlets per pump must be installed. Suction outlets in the same plane (i.e. floor or wall), must be installed a minimum of three feet (3') [0.91 meter] apart, as measured from near point to near point.**
 - Dual suction fittings shall be placed in such locations and distances to avoid “dual blockage” by a user.
 - Dual suction fittings shall not be located on seating areas or on the backrest for such seating areas.
 - The maximum system flow rate shall not exceed the values shown in the “Pipe Sizing Chart” found at this manual.
 - **NEVER** use pool or spa if any suction outlet component is damaged, broken, cracked, missing, or not securely attached.
 - Replace damaged, broken, cracked, missing, or not securely attached suction outlet components immediately.
 - Installation of a vacuum release or vent system, which relieves entrapping suction, is recommended.

- **Hazardous Pressure:** Pool and spa water circulation systems operate under hazardous pressure during start-up, normal operation, and after pump shut-off. Stand clear of circulation system equipment during pump start-up. Failure to follow safety and operation instructions could result in violent separation of the pump housing and cover due to pressure in the system, which could cause property damage, severe personal injury, or death. Before servicing pool and spa water circulation system, all system and pump controls must be in off position and filter manual air relief valve must be in open position. Before starting system pump, all system valves must be set in a position to allow system water to return back to the pool. **DO NOT** change filter control valve position while system pump is running. Before starting system pump, fully open filter manual air relief valve. **DO NOT** close filter manual air relief valve until a steady stream of water (not air or air and water) is discharged. All suction and discharge valves **MUST** be **OPEN** when starting the circulation system. Failure to do so could result in severe personal injury and/or property damage.
- **Separation Hazard:** Failure to follow safety and operation instructions could result in violent separation of pump components. Strainer cover must be properly secured to pump housing with strainer cover lock ring. Before servicing pool and spa circulation system, all system and pump controls must be in off position and filter manual air relief valve must be in open position. **DO NOT** operate pool and spa circulation system if a system component is not assembled properly, damaged, or missing. **DO NOT operate pool and spa circulation system unless filter air relief valve body is in locked position in filter upper body.** All suction and discharge valves **MUST be OPEN** when starting the circulation system. Failure to do so could result in severe personal injury and/or property damage. **NEVER** operate or test the circulation system at more than 40 PSI.
- **Fire and Burn Hazard:** Motors operate at high temperatures and if they are not properly isolated from any flammable structures or foreign debris they can cause fires, which may cause severe personal injury or death. It is also necessary to allow the motor to cool for at least 20 minutes prior to maintenance to minimize the risk for burns.
- This product should be installed and serviced only by a qualified professional.
- If pump is being pressure tested (40 PSI MAXIMUM), be sure pressure has been released, using the filter manual air relief valve, before removing strainer cover.
- **NEVER** run pump dry. Running pump dry may damage seals, causing leakage, flooding, and voids warranty. Fill strainer housing with water before starting motor.
- Match supply voltage to motor nameplate voltage. Insure that the electrical supply available agrees with the motor's voltage, phase, and cycle, and that the wire size is adequate for the H.P. (KW) rating and distance from the power source.
- All suction and discharge valves **MUST be OPEN**, as well as filter air relief valve (if available) on filter, when starting the circulating pump system. Failure to do so could result in severe personal injury.
- To avoid dangerous or fatal electrical shock hazard, turn **OFF** power to motor before draining pump. Failure to disconnect power may result in serious personal injury or death.
- **DO NOT** use anti-freeze solutions (except propylene glycol) in your pool/spa system. Propylene glycol is non-toxic and will not damage plastic system components; other anti-freezes are highly toxic and may damage plastic components in the system.

DIAGRAM AND SPECIFICATIONS

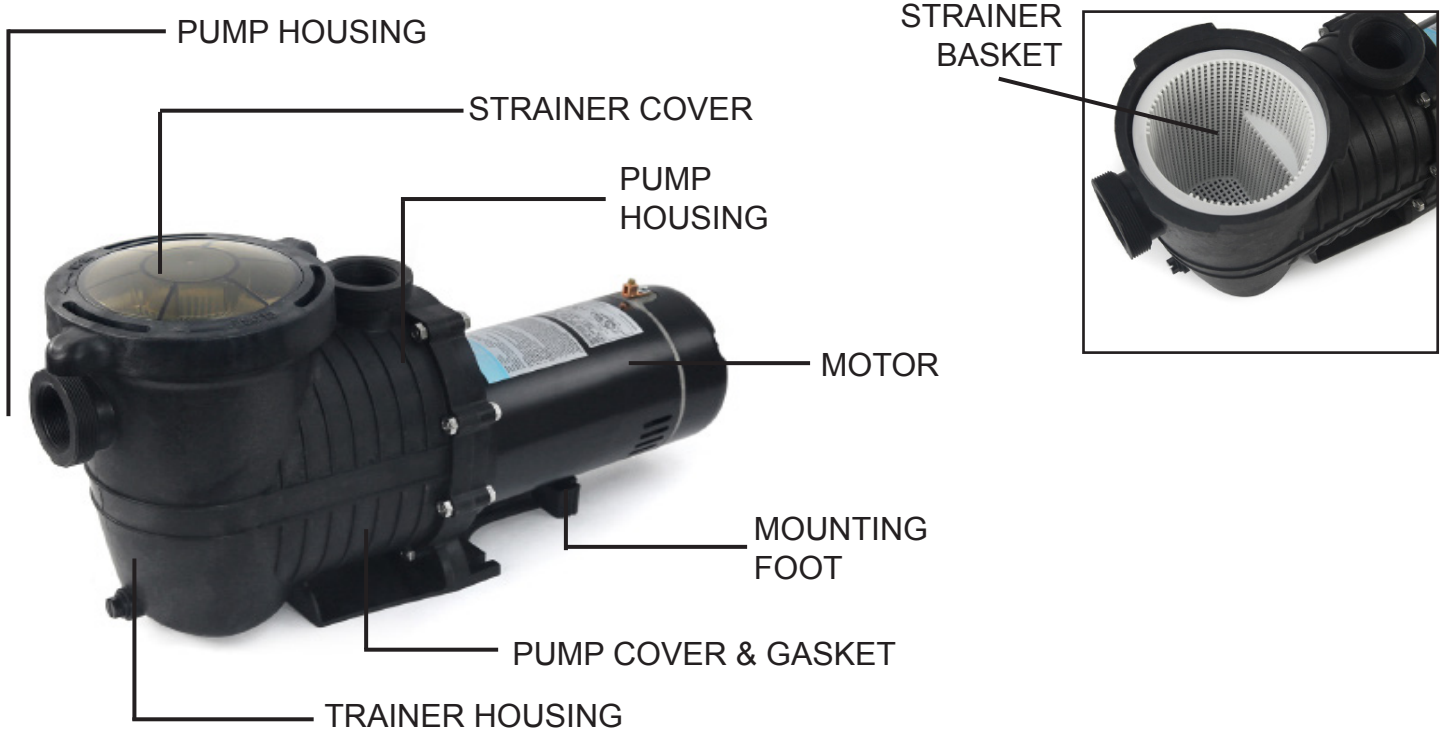

Assembled Product Dimensions (L x W x H) 25.0 x 14.0 x 9.0 Inches

FEATURES AND SPECIFICATIONS

1.5 HP In-Ground Pump also work with above. Compatible with DE, sand, and cartridge filter. Self-priming for in-ground functionality/font. Can be installed as 115V or 230V.

- Heavy Duty Long Lasting Case
- In-ground pools of all types and sizes (including in-floor cleaning systems, solar heating systems, water features)
- In-ground spas or in-ground pool/spa combinations Fountains
- Full flow hydraulics allow greater flow at a lower cost of operation
- Save electricity and money with high efficiency single-speed motor
- Heavy-duty, high-performance motor with airflow ventilation for quieter, cooler operation
- See-through cover so pool owners know exactly when to empty the extra-large debris basket
- Uni-Bracket mounting base provides stable, stress-free support, plus versatility for any installation requirements.
- 1.5HP 3450RPM
- Single Phase
- 5280GPH
- Max 66FT
- 115/230V Dual Watt
- AMP15 / 7.5
- MAX WATER TEMP 104 F
- Dual threaded 1.5" and 2"
- Thermal Protected
- Dimension 24" L x 12" (H) x 9" (W)
- UL Listed
- CSA Certificated
- ETL Listed

INSTALLATION

PUMP LOCATION

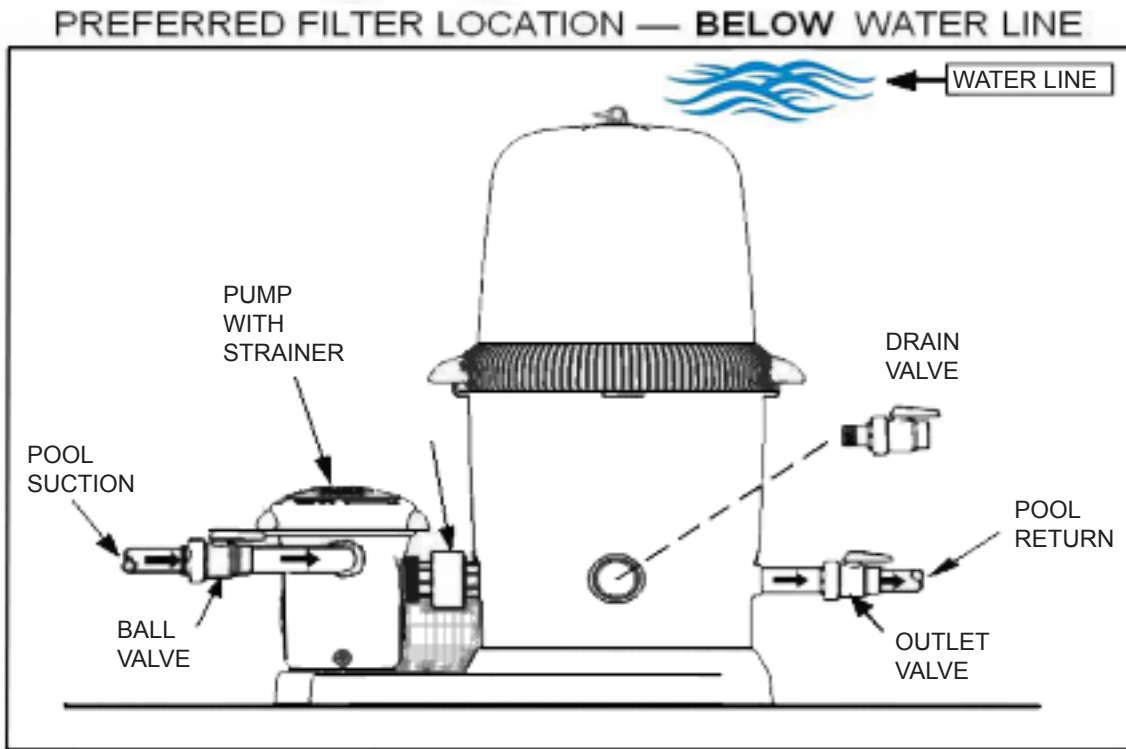

Locate the system below the pool water line, for best pump performance. Install pump on a firm, level base or pad to meet all local and national codes. The field supplied base or pad must be level. Though the pump is designed for outdoor use, it is strongly advised to protect the electrical components from the weather. Select a well-drained area, one that will not flood when it rains. Pump motors require free circulation of air for cooling. **DO NOT** install pump in a damp or non-ventilated location.

1. Pump Mounting

Install pump on a firm, level base or pad to meet all local and national codes. Fasten pump to base or pad with screws or bolts to further reduce vibration and stress on pipe or hose joints. The base **MUST** be solid, level, rigid, and vibration free.

Pump mount must:

- Allow pump inlet height to be as close to water level as possible.
- Allow use of short, direct suction pipe (to reduce friction losses).
- Allow for gate valves in suction and discharge piping.
- Be protected from excess moisture and flooding.
- Allow adequate access for servicing pump and piping.

PIPE SIZING CHART

| PIPE SIZE (mm) | 1" (32) | 1 1/4" (40) | 1 1/2" (50) | 2" (63) | 2 1/2" (75) | 3" (90) |
|---------------------------|---------|-------------|-------------|----------|-------------|-----------|
| FLOW RATE GPM (Liter/Min) | 20 (75) | 30 (110) | 45 (170) | 80 (300) | 110 (415) | 160 (600) |

NOTE: It is recommended that a minimum length of piping, equivalent to 10 pipe diameters, be used between the pump suction inlet and any plumbing fittings.

INSTALLATION

- Fasten pump to base or pad with screws or bolts to reduce vibration and stress on pipe or hose joints.
- We recommend a minimum clearance around the pad of 18" to allow adequate access for servicing pump and piping.

PLUMBING

- Installing union connections at the suction and outlet ports is recommended, to facilitate servicing of pump and to allow for indoor storage during the winter months.
- Use Teflon tape to seal threaded connections on molded plastic components. All plastic fittings must be new or thoroughly cleaned before use. **NOTE: DO NOT** use Plumber's Pipe Dope as it may cause cracking of the plastic components.
- When applying Teflon tape to plastic threads, wrap the entire threaded portion of the male fitting with one to two layers of tape. Wind the tape clockwise as you face the open end of the fitting, beginning at the end of the fitting.
- The pump suction and outlet ports have molded-in thread stops. **DO NOT** attempt to force hose connector fitting past this stop. It is only necessary to tighten fittings enough to prevent leakage. Tighten fitting by hand and then use a tool to engage fitting an additional 1 ½ turns. Use care when using Teflon tape as friction is reduced considerably; **DO NOT** over-tighten fitting or you may cause damage. If leaks occur, remove connector, clean off old Teflon tape, re-wrap with one to two additional layers of Teflon tape, and re-install connector.



Risk of Electric Shock. All electrical wiring **MUST** be in conformance with applicable local codes, regulations, and the National Electric Code (NEC). All electrical wiring should be performed by a qualified professional. Hazardous voltage can shock, burn, and cause death or serious property damage. To reduce the risk of electric shock, **DO NOT** use an extension cord to connect unit to electric supply. Provide a properly located electrical receptacle. Before working on any electrical equipment, turn off power supply to the equipment. To reduce the risk of electric shock replace damaged wiring immediately. **DO NOT** ground to a gas supply line.

The electrical equipment must be connected only to a supply circuit that is protected by a ground-fault circuit-interrupter (GFCI). Such a GFCI should be provided by the installer and should be tested on a routine basis. To test the GFCI, push the test button. The GFCI should interrupt power. Push reset button. Power should be restored. If the GFCI fails to operate in this manner, the GFCI is defective. If the GFCI interrupts power to the electrical equipment without the test button being pushed, a ground current is flowing, indicating the possibility of an electrical shock. **DO NOT** use this electrical equipment. Disconnect the electrical equipment and have the problem corrected by a qualified service representative before using. Insure that the electrical supply available agrees with the motor's voltage, phase, and cycle, and that the wire size is adequate for the KW rating and distance from the power source.

Voltage at motor **MUST NOT** be more than 10% above or below motor name plate rated voltage, or motor may overheat, causing overload tripping and reduced component life. If voltage is less than 90% or more than 110% of rated voltage when motor is running at full load, consult power company.

Failure to bond all electrical equipment to pool structure will increase risk for electrocution and could result in injury or death. To reduce the risk of electric shock, see installation instructions and consult a professional electrician on how to bond all electrical equipment. Also, contact a licensed electrician for information on local electrical codes for bonding requirements.

START-UP AND OPERATION

PUMP DISCHARGE POSITION

- **Step 1:** Remove ALL plumbing attached to pump.
Remove pump from base (if applicable).
- **Step 2:** Remove strainer housing.
 - Disengage and lift off strainer cover.
 - Remove strainer basket.
 - Lift up on strainer 'C' clip and remove.
 - Slide strainer housing forward and remove.
- **Step 3:** Press positioning button located on pump housing and rotate discharge port to desired position.
- **Step 4:** Assemble the pump by following the above directions in the reverse manner.

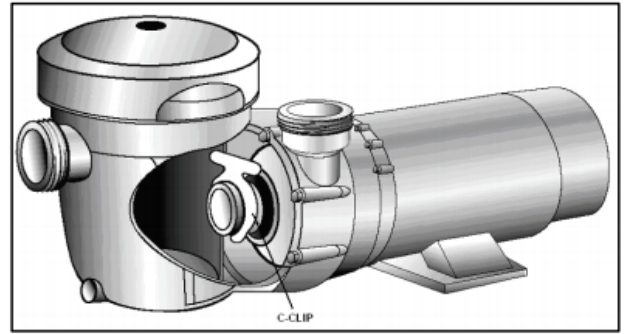

PRIOR TO START-UP

Fill strainer housing with water to suction pipe level. **NEVER** operate the pump without water. Water acts as a coolant and lubricant for the mechanical shaft seal.



NEVER run pump dry. Running pump dry may damage seals, causing leakage and flooding. Fill strainer housing with water before starting motor.

DO NOT add chemicals to pool/spa system directly in front of pump suction. Adding undiluted chemicals may damage pump and voids warranty.

Before removing strainer cover:

1. **STOP PUMP** before proceeding.
2. **CLOSE VALVES** in suction and outlet pipes.
3. **RELEASE ALL PRESSURE** from pump and piping system.

If pump is being pressure tested, be sure pressure has been released before removing strainer cover.

PRIMING THE PUMP

- Clean and lubricate strainer cover O-ring with "Jack's 327" each time it is removed.
- Clean and inspect O-ring; re-install on strainer cover.
- Replace strainer cover on strainer housing; turn clockwise to tighten cover. **NOTE: Tighten strainer cover by hand only (no wrenches) ¼ turn.**
- Open all valves before starting system.
- Release all air from filter and piping system.
- With suction and outlet valves open and water source higher than the pump and flowing, pump will prime itself.

If pump does **NOT** prime within ten minutes, stop motor and determine cause. Be sure all suction and discharge valves are open when pump is running. See Troubleshooting Guide.

OPERATION



EXPLOSION HAZARD: Purging the system with compressed air can cause components to explode, with risk of severe injury or death to anyone nearby. Use only a low pressure (below 5 PSI), high volume blower when air purging the pump, filter, or piping.

Allowing the pump to freeze will void the warranty.

DO NOT use anti-freeze solutions (except propylene glycol) in your pool/spa system. Propylene glycol is non-toxic and will not damage plastic system components; other anti-freezes are highly toxic and may damage plastic components in the system. Gravity drain system as far as possible.

PUMP WINTERIZATION STORAGE



ELECTRICAL HAZARD: To avoid dangerous or fatal electrical shock hazard, turn **OFF** power to motor before draining pump.

Drain all water from pump and piping when expecting freezing temperatures or when storing pump.

1. Drain water level below all inlets to the pool.
2. Remove drain plug from bottom of strainer body.
3. Disconnect pump from base.
4. Once the pump is drained of water, re-install the strainer lid and strainer plug.
5. Store pump in a dry enclosure. Keep motor dry and covered during storage. To avoid condensation/corrosion problems, **DO NOT** cover or wrap pump with plastic film or bags.

START-UP FOR WINTERIZED EQUIPMENT

1. Securely mount pump to base.
2. Install all intake and output fittings and piping.
3. Refill pool to proper water level.
4. Prime pump according to instructions.

SHAFT SEAL CHANGE INSTRUCTIONS



Only qualified personnel should attempt rotary seal replacement. Risk of Electric Shock Failure to turn off power can cause serious or fatal electrical shock hazard. Disconnect all electrical power service to pump before beginning shaft seal replacement.

Exercise extreme care in handling both the rotating and the stationary sections of the two-part replacement seal. Foreign matter or improper handling will easily scratch the graphite and ceramic sealing surfaces.

SHAFT SEAL CHANGE INSTRUCTIONS

1. Shut off water flow to pump by closing appropriate valves or by plugging both the skimmer outlet port and return port to pool. Disconnect piping or hoses from the motor/pump assembly.
2. Remove the strainer by disengaging and removing the strainer cover. Remove the basket. Lift up on strainer 'C' clip and remove. Finally, slide strainer housing forward and remove.
3. Unscrew screws and remove pump cover, exposing the impeller.
4. Remove the canopy or the shaft cover plate from the end of motor opposite the impeller.
5. Hold the motor shaft securely by either inserting a screwdriver in slot at end of shaft or by using an open-end wrench to engage the flat surfaces provided near end of motor shaft. Rotate the impeller in a counter-clockwise direction and remove it from the motor shaft.
6. Note how the steel spring section of the old seal is positioned on impeller hub and remove it by pulling from the impeller.
7. Loosen motor through bolts from the back of motor and remove pump housing/shroud from the front of the motor.
8. Remove the ceramic stationary portion of the old seal by pressing the white ceramic seat out of the pump housing recess. If assembly is tight, tap lightly from the "motor" side.
9. Clean and lubricate the impeller stem and the pump housing recess with a dilute solution of non-granulated liquid type soap. Do not use petroleum or silicone lubricants as these can contribute to seal leakage.
10. Press the new rotating portion of the seal assembly onto the impeller stem with the polished black graphite surface facing away from the impeller.
11. Carefully press the stationary ceramic portion of the seal into the recess of the pump housing/shroud, with the polished flat surface facing out.
12. Carefully insert the motor shaft through the pump housing/shroud and align with white ceramic stationary seal assembly in place and secure the motor to pump housing/shroud with motor through bolts. Be sure motor base and pump discharge port are positioned properly. Alternately tighten the motor through bolts until the pump housing is secure. Make certain motor shaft turns freely before proceeding.
13. Screw the impeller (clockwise) with the rotating portion of seal in place onto the motor shaft. Hand-tighten the impeller in place.
14. Clean (replace if necessary) the O-ring and replace on pump cover. Assemble the pump cover to the pump housing/ shroud with the screws. Tighten screws alternately and evenly.
15. Re-assemble strainer by sliding strainer housing onto pump cover. Install strainer 'C' clip by pushing clip down onto grooved pump cover coupling. Insert basket and fasten strainer cover.
16. Reconnect pump to the piping or hoses provided. Open all valves and make sure that the pump strainer housing is full of water before restarting the pump.

TROUBLESHOOTING

| ISSUE | POSSIBLE SOLUTION |
|-------------------------------|---|
| MOTOR WILL NOT START | Improper or loose wiring connections; open switches or relays; tripped circuit breakers, GFCI's, or blown fuses. |
| | Manually check rotation of motor shaft for free movement and lack of obstruction. |
| | If you have a timer, be certain it is working properly. Bypass it if necessary. |
| MOTOR SHUTS OFF | Undersized wiring; loose connections; etc. |
| | Low voltage at motor or power drop (frequently caused by undersized wiring or extension cord use). |
| | Mechanical binding and electrical overload. |
| MOTOR HUMS BUT DOES NOT START | Centrifugal switch stuck in OPEN position. |
| | Binding of motor shaft. |
| PUMP WON'T PRIME | Make sure pump/strainer housing is filled with water and the cover O-ring is clean, also be sure it is properly seated in the cover O-ring groove. Make sure strainer cover is locked firmly in position and lubricated with "Jack's 327." |
| | Make sure all suction and discharge valves are fully open and not blocked, that pool water level is at proper level, and that skimmer weir is not hung up or stuck on skimmer wall. |
| | Block off to determine if pump will develop a vacuum. You should have 5"-6" of vacuum at the strainer cover. You may be able to check by removing the skimmer basket and holding your hand over the bottom port with skimmer full and pump running. If no suction is felt, check for line blockage. |
| | a. If pump develops a vacuum, check for blocked suction line or dirty strainer basket, an air leak in the suction piping may be the cause. |
| | b. If pump does not develop a vacuum and pump has sufficient "priming water": i. Re-check strainer housing cover and all threaded connections for suction leaks. Check if all hose clamps are tight. ii. Check voltage to ensure that the motor is rotating at full RPM's. iii. Open housing cover and check for clogging or obstruction in suction. Check impeller for debris. iv. Remove and replace shaft seal only if it is leaking. |
| LOW FLOW | Clogged or restricted strainer or suction line; undersized pool piping. |
| | Plugged or restricted discharge line or filter, valve partially closed (high gauge reading). How to correct: Sand filters – backwash as per manufacturer's instructions; D.E. filters – backwash as per manufacturer's instructions; Cartridge filters – clean or replace cartridges. |
| | Air leak in suction (bubbles issuing from return fittings). Re-tighten using Teflon tape. |
| | Plugged or restricted impeller or impeller sheared off. Replace including new seal assembly. |
| NOISY PUMP | Air leak in suction piping causing rumbling in pump. |
| | Cavitation due to restricted or undersized suction line or leak at any joint, low water level in pool, and unrestricted discharge return lines. Correct suction condition or throttle return lines, if practical. Holding hand over return fitting will sometimes prove this point or putting in a smaller eyeball fitting. |
| | Vibration due to improper mounting, etc. Put a rubber pad under metal mounting feet. |
| | Foreign matter in pump housing. Loose stones/debris hitting impeller could be cause, remove any of the above. |
| | Motor bearings noisy from normal wear, rust, overheating, or concentration of chemicals causing seal damage which will allow chlorinated water to seep into bearings wiping out the grease causing bearing to whine. All seal leaks should be replaced at once. |
| Equipment base vibrating. | |

MAINTENANCE

- Clean strainer basket regularly. **DO NOT** strike basket to clean. Inspect strainer cover gasket regularly and replace as necessary.
- Keep motor clean. Insure air vents are free from obstruction.
- Occasionally, shaft seals must be replaced, due to wear or damage.

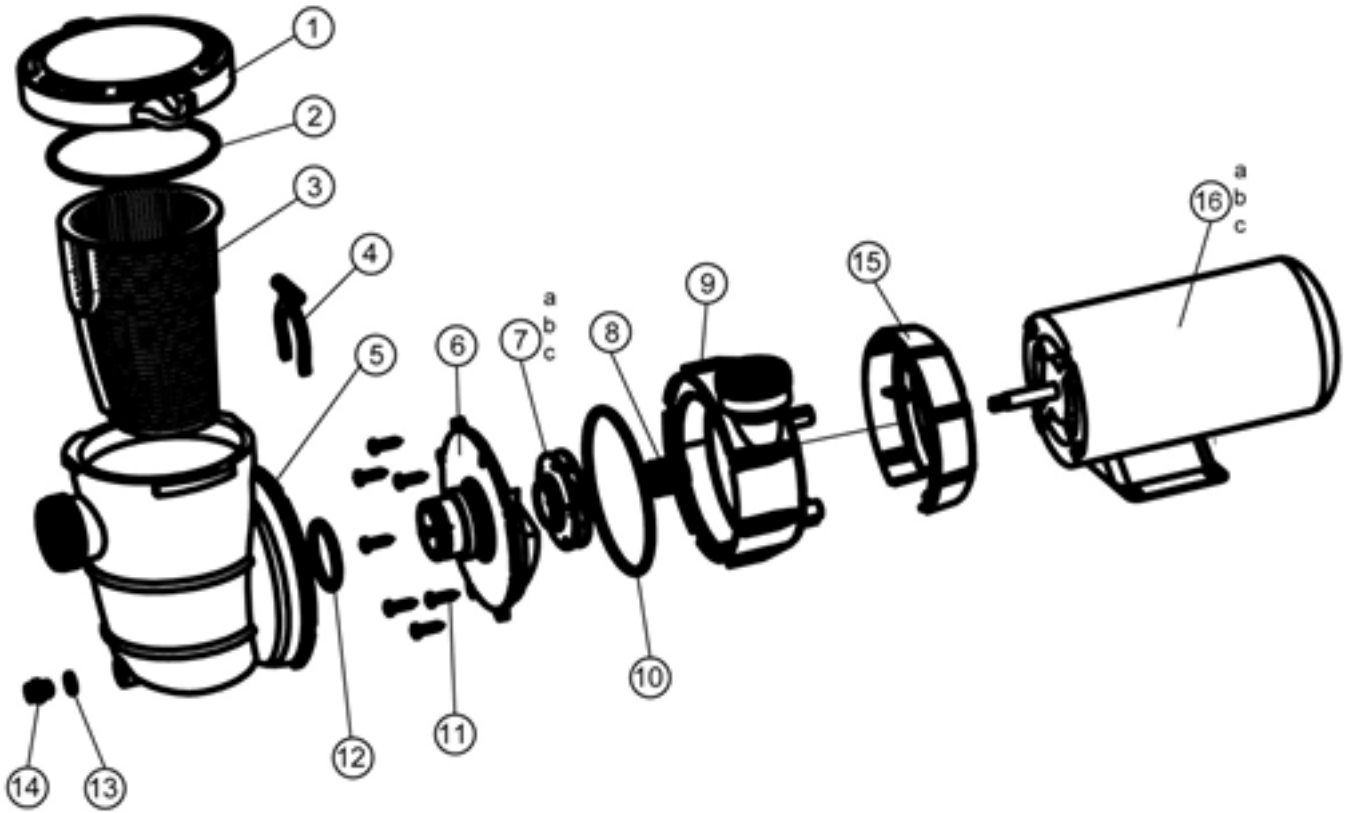

| # | DESCRIPTION | QTY |
|----|----------------------|-----|
| 1 | COVER | 1 |
| 2 | O-RING | 1 |
| 3 | BASKET | 1 |
| 4 | CLIP | 1 |
| 5 | STRAINER HOUSING | 1 |
| 6 | PUMP COVER | 1 |
| 7 | IMPELLER | 1 |
| 8 | SEAL ASSEMBLY | 1 |
| 9 | PUMP HOUSING | 1 |
| 10 | O-RING | 1 |
| 11 | SCREW 5 X 25 | 8 |
| 12 | O-RING | 1 |
| 13 | GASKET | 1 |
| 14 | DRAIN PLUG | 1 |
| 15 | MOTOR MOUNTING PLATE | 1 |
| 16 | MOTOR | 1 |

PLEASE READ THE FOLLOWING CAREFULLY

THE MANUFACTURER AND/OR DISTRIBUTOR HAS PROVIDED THE PARTS LIST AND ASSEMBLY DIAGRAM IN THIS MANUAL AS A REFERENCE TOOL ONLY. NEITHER THE MANUFACTURER OR DISTRIBUTOR MAKES ANY REPRESENTATION OR WARRANTY OF ANY KIND TO THE BUYER THAT HE OR SHE IS QUALIFIED TO MAKE ANY REPAIRS TO THE PRODUCT, OR THAT HE OR SHE IS QUALIFIED TO REPLACE ANY PARTS OF THE PRODUCT. IN FACT, THE MANUFACTURER AND/OR DISTRIBUTOR EXPRESSLY STATES THAT ALL REPAIRS AND PARTS REPLACEMENTS SHOULD BE UNDERTAKEN BY CERTIFIED AND LICENSED TECHNICIANS, AND NOT BY THE BUYER. THE BUYER ASSUMES ALL RISK AND LIABILITY ARISING OUT OF HIS OR HER REPAIRS TO THE ORIGINAL PRODUCT OR REPLACEMENT PARTS THERETO, OR ARISING OUT OF HIS OR HER INSTALLATION OF REPLACEMENT PARTS THERETO.

Record Product's Serial Number Here: _____

Note: If product has no serial number, record month and year of purchase instead.

Note: Some parts are listed and shown for illustration purposes only and are not available individually as replacement parts.



SAVE THESE INSTRUCTIONS.



Questions, problems, missing parts?

Before returning to your retailer, our exceptional customer service is available.

Call us Tel: **909 628 0880**

Hour : **9am To 3pm PST (Monday to Friday)**

Email : **customer@xtremepowerusa.com**