

REVISIONS		
REV.	DESCRIPTION	DATE
AB	Added 2" to tray and changed ba	9/27/06
AC	Remove welding operations	2/14/07
AD	Changed to .875 bearing	11/1/07
AE	Changed to 1.0325 slot, changed tray sides, added rear rubber stops	8/8/12
AF	moved front guide bearing hole back 2"	10/11/13
AG	Change BA and material on tray (3/16)	8/24/15
AH	changed width from 50" to 49.375"	10/26/16
AI	Update to handle under tray	1/10/17

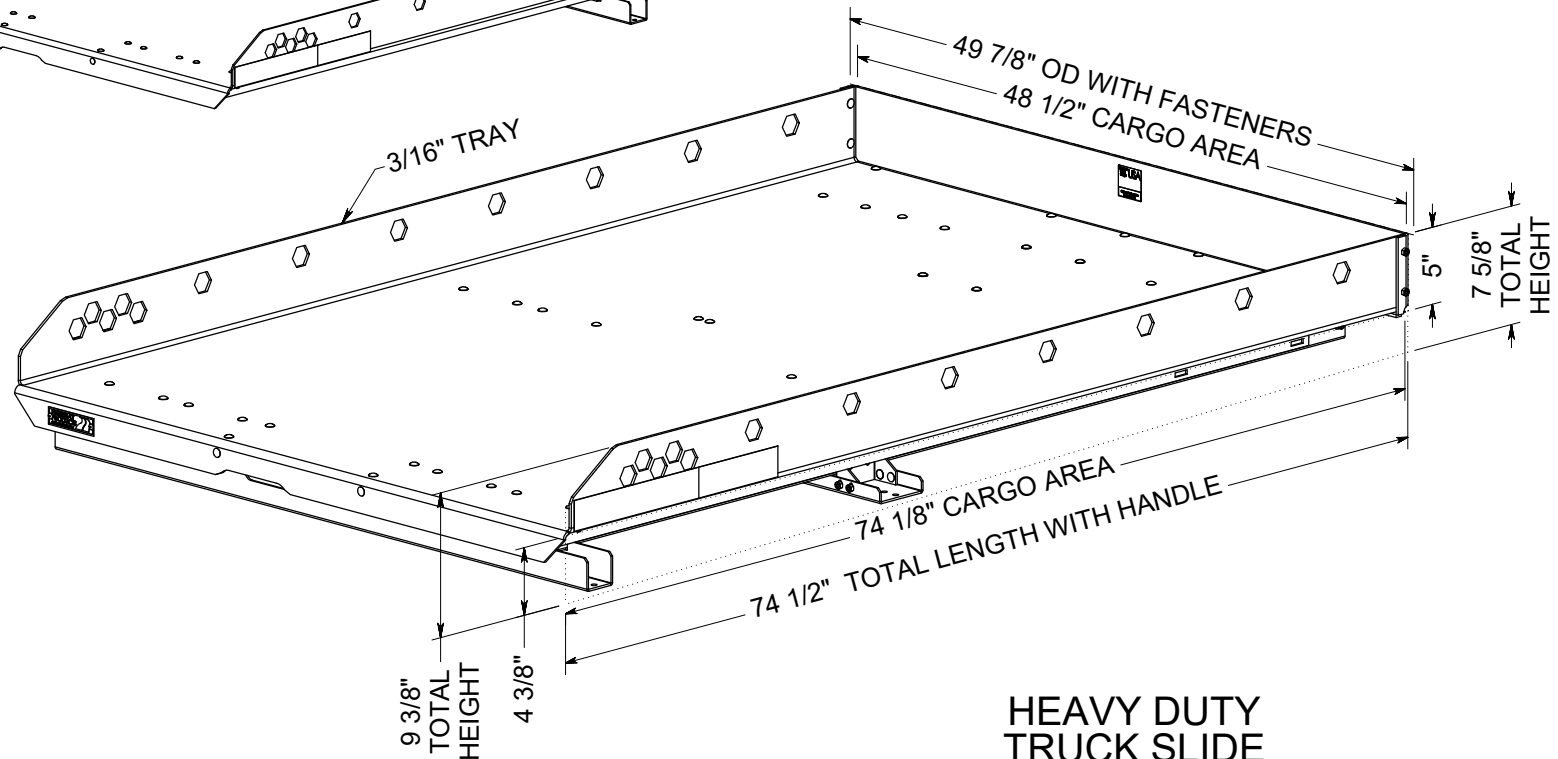
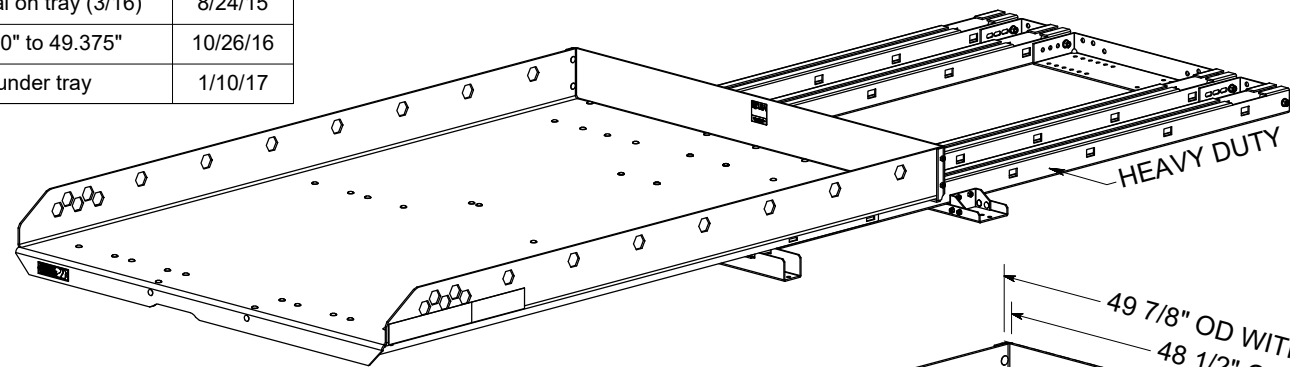
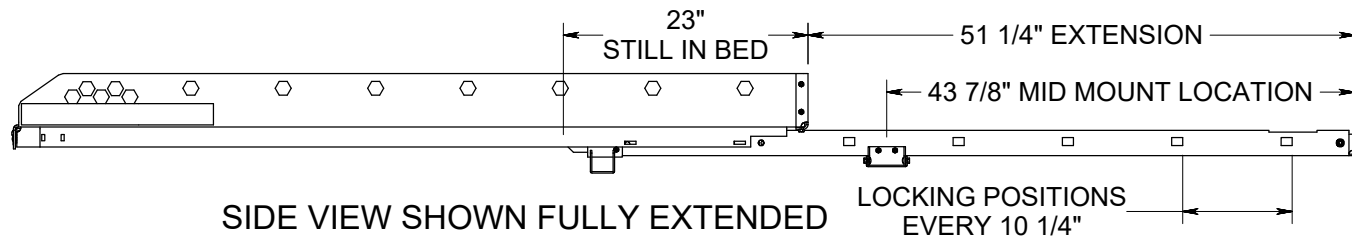

**HEAVY DUTY
TRUCK SLIDE
OVERALL DIMENSIONS
49 7/8" x 9 3/8" x 74 1/2"**

SPECIAL INSTRUCTIONS:

MATERIAL: AL & 10ga GALV		PROJECT #: 491
FINISH: SMOOTH		DRAWN BY: Sheldon Bywater
REVISION: AI	APVL BY: EBF	ENG DATE: 10/06/2015
Ov1	SALE BY:	TOLERANCES: ANGULAR $\pm 2^\circ$ FRACTIONAL $\pm 3/16"$ TWO PLACE DECIMAL $\pm .125$ THREE PLACE DECIMAL $\pm .0625$

HIGHWAY PRODUCTS
1-800-TOOL BOX
FAX 1-800-465-9545
800TOOLBOX.COM

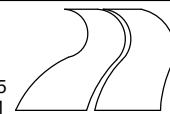

CUSTOMER:

APPROVAL SIGNATURE _____

YOUR PRODUCTION LEAD TIME WILL BEGIN AS SOON AS WE RECEIVE YOUR SIGNATURE APPROVAL ON THE PRINTS WITHOUT ANY REQUESTS FOR CHANGES. THANK YOU.

CUSTOMER SPECIAL INSTRUCTIONS:

PC LX FI