



Pro-Panel II[®] Install Guide

The application and detail drawings in this manual are strictly for illustration purposes and may not be applicable to all building designs or product installations. All projects should conform to applicable building codes for that particular area. It is recommended to follow all building regulations and standard industry practices.

Metal Sales Manufacturing Corporation is not responsible for the performance of the roof system if it is not installed in accordance with the suggested instructions referenced in this installation manual or in the product overview. (See Product Manual or Product Technical Literature). If there is a conflict between this manual and the actual erection drawings, the erection drawings are to take precedence.

Prior to ordering and installing materials, all dimensions should be verified by field measurements.

Metal Sales reserves the right to modify, without notice, any details, recommendations or suggestions. Any questions you may have regarding proper installation of the roofing system should be directed to your Metal Sales representative, see pages 2 and 3.

Consult Metal Sales for any additional information not outlined in this manual.

This manual is designed to be utilized as a guide when installing Post Frame and Residential roofing systems. It is the responsibility of the erector to ensure the safe installation of this product system.

SAFETY

STUDY APPLICABLE OSHA AND OTHER SAFETY REQUIREMENTS BEFORE FOLLOWING THESE INSTRUCTIONS.

The installation of metal roof systems is a dangerous procedure and should be supervised by trained knowledgeable erectors. **USE EXTREME CARE WHILE INSTALLING ROOF PANELS.** It is not possible for Metal Sales to be aware of all the possible job site situations that could cause an unsafe condition to exist. The erector of the roof system is responsible for reading these instructions and determining the safest way to install the roof system.

These instructions are provided only as a guide to show a knowledgeable, trained erector the correct part placement one to another. If following any of the installation steps would endanger a worker, the erector should stop work and decide upon a corrective action.

Provide required safety railing, netting, or safety lines for crew members working on the roof.

Do not use the roof panel as a walking platform. The roof panels will not withstand the weight of a person standing at the edge of the panel.

Do not stand on the roof panel until the panels have been attached.

ms metal sales
manufacturing corporation

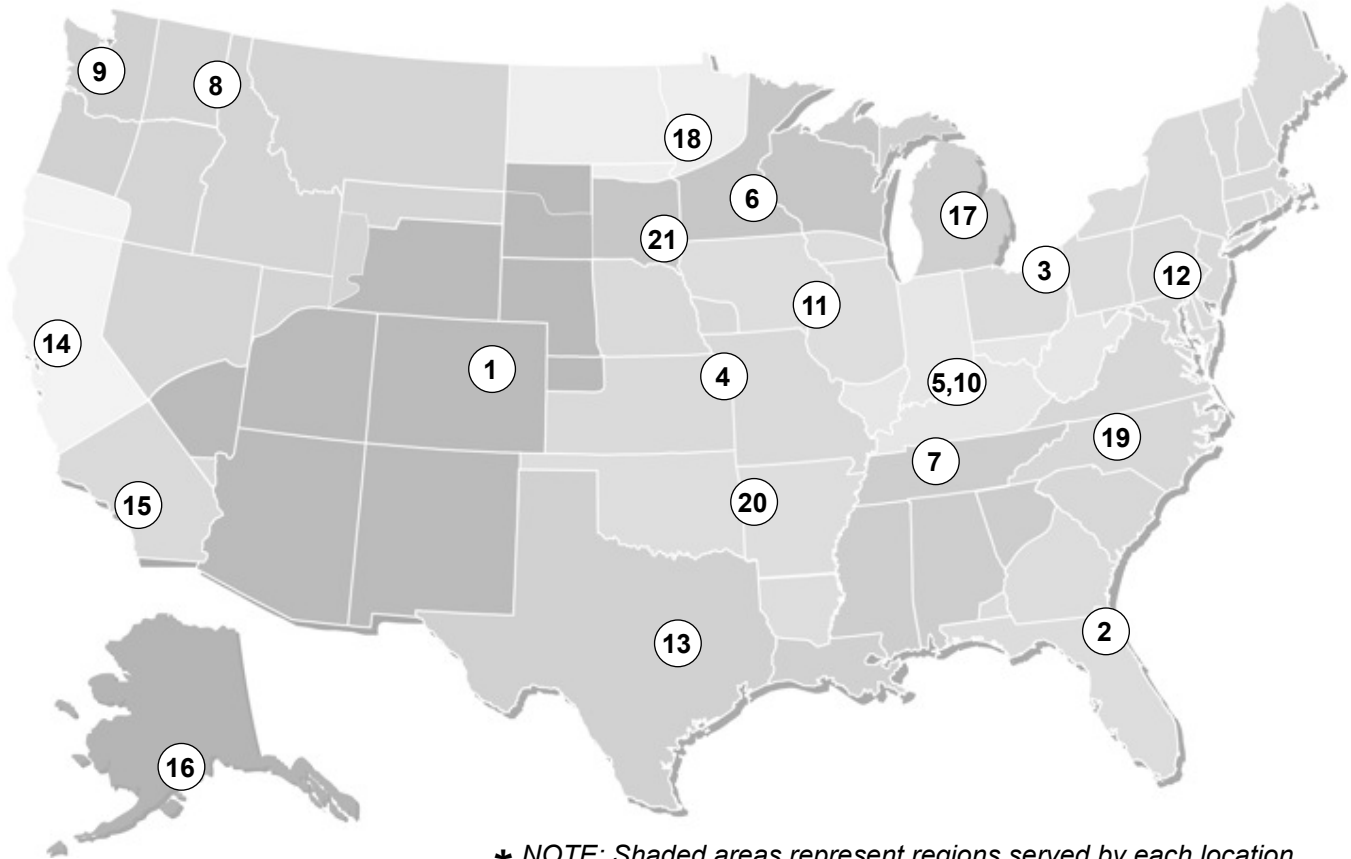

* NOTE: Shaded areas represent regions served by each location.

For more than 50 years, Metal Sales Manufacturing Corporation has earned a reputation as the premier provider of innovative metal building components and accessories.

We've backed this reputation with the industry's largest professional sales and services team. We offer a full line of exceptional quality metal roof and wall panels for agricultural, commercial, architectural, industrial, and residential projects of every shape and size, new construction or retro-fit.

1.) DENVER BRANCH

7990 E. I-25 Frontage Road
Longmont, CO 80504
303.702.5440 Phone
800.289.7663 Toll Free
800.289.1617 Toll Free Fax

2.) JACKSONVILLE BRANCH

7110 Stuart Avenue
Jacksonville, FL 32254
904.783.3660 Phone
800.394.4419 Toll Free
904.783.9175 Fax
800.413.3292 Toll Free Fax

3.) JEFFERSON BRANCH

352 East Erie Street
Jefferson, OH 44047
440.319.3779 Phone
800.321.5833 Toll Free
440.576.9242 Fax
800.233.5719 Toll Free Fax

4.) INDEPENDENCE BRANCH

1306 South Powell Road
Independence, MO 64057
816.796.0900 Phone
800.747.0012 Toll Free
816.796.0906 Fax

5.) SELLERSBURG BRANCH

7800 State Road 60
Sellersburg, IN 47172
812.246.1866 Phone
800.999.7777 Toll Free
812.246.0893 Fax
800.477.9318 Toll Free Fax

6.) ROGERS BRANCH

22651 Industrial Boulevard
Rogers, MN 55374
763.428.8080 Phone
800.328.9316 Toll Free
763.428.8525 Fax
800.938.9119 Toll Free Fax

7.) NASHVILLE BRANCH

4314 Hurricane Creek Boulevard
Antioch, TN 37013
615.229.6570 Phone
800.251.8508 Toll Free
615.283.4283 Fax
800.419.4372 Toll Free Fax

8.) SPOKANE BRANCH

East 2727 Trent Avenue
Spokane, WA 99202
509.536.6000 Phone
800.572.6565 Toll Free
509.534.4427 Fax

9.) SEATTLE BRANCH

20213 84th Avenue, South
Kent, WA 98032
253.872.5750 Phone
800.431.3470 Toll Free (Outside WA)
800.742.7900 Toll Free (Inside WA)
253.872.2008 Fax

10.) NEW ALBANY BRANCH

999 Park Place
New Albany, IN 47150
812.944.2733 Phone
812.944.1418 Fax

11.) ROCK ISLAND BRANCH

8111 West 29th Street
Rock Island, IL 61201
309.787.1200 Phone
800.747.1206 Toll Free
309.787.1833 Fax

12.) DEER LAKE BRANCH

29 Pinedale Industrial Road
Orwigsburg, PA 17961
570.366.2020 Phone
800.544.2577 Toll Free
570.366.1648 Fax
800.544.2574 Toll Free Fax

13.) TEMPLE BRANCH

3838 North General Bruce Drive
Temple, TX 76501
254.791.6650 Phone
800.543.4415 Toll Free
254.791.6655 Fax
800.543.4473 Toll Free Fax

14.) WOODLAND BRANCH

1326 Paddock Place
Woodland, CA 95776
530.668.5690 Phone
800.759.6019 Toll Free
530.668.0901 Fax

15.) FONTANA BRANCH

14213 Whittram Avenue
Fontana, CA 92335
909.829.8618 Phone
800.782.7953 Toll Free
909.829.9083 Fax

16.) ANCHORAGE BRANCH

4637 Old Seward Highway
Anchorage, AK 99503
907.646.7663 Phone
866.640.7663 Toll Free
907.646.7664 Fax

17.) BAY CITY BRANCH

5209 Mackinaw Road
Bay City, MI 48706
989.686.5879 Phone
888.777.7640 Toll Free
989.686.5870 Fax
888.777.0112 Toll Free Fax

18.) DETROIT LAKES BRANCH

1435 Egret Avenue
Detroit Lakes, MN 56501
218.847.2988 Phone
888.594.1394 Toll Free
218.847.4835 Fax
888.594.1454 Toll Free Fax

19.) MOCKSVILLE BRANCH

188 Quality Drive
Mocksville, NC 27028
704.859.0550 Phone
800.228.6119 Toll Free
704.859.0157 Fax
800.228.7916 Toll Free Fax

20.) FORT SMITH BRANCH

7510 Ball Road
Fort Smith, AR 72908
479.646.1176 Phone
877.452.3915 Toll Free
479.646.5204 Fax

21.) SIOUX FALLS BRANCH

2700 West 3rd Street, Suite 4
Sioux Falls, SD 57104
605.335.2745 Phone
888.299.0024 Toll Free

TECHNICAL SUPPORT**TECHNICAL SERVICES**

545 South 3rd Street, Suite 200
Louisville, KY 40202
502.855.4300 Phone
800.406.7387 Toll Free
502.855.4290 Fax
800.944.6884 Toll Free Fax

General Information	PAGE NO.
Important Information	1
Metal Sales' Locations	2
Customer Service	3
Panel Information	
Panel Overview	6
Testing and Approvals	6
Fastening Patterns	6
Panel Lap Detail	7
Section Properties	7
Pro-Panel II Fastener Installation.....	8
Post Frame Flashing Profiles	9-11
Residential Flashing Profiles	12
Accessory Profiles	13
Handling Material	
Receiving Material	14
General Handling	14
Mechanical Handling	14
Manual Handling	15
Storage	
General	16
Foot Traffic	16
Required Tools.....	16
Design / Installation Considerations	
General.....	17
Condition of Substructure	17
Field Cutting and Touch-Up	
Field Cutting.....	18
Touch-Up Paint	18
Ventilation	18
Fastener Selection Guide	19
Installation Overview	20
Post Frame Panel Installation	
Installing Inside Closures (Step 1).....	21
Installing First Panel (Step 2).....	21
Installing Endlap Panel (Step 3)	22
Installing Sidelap Panel (Step 4).....	22
14" Universal Ridge Detail.....	23
Low Profile Ridge Vent	23
Outside Corner Detail	23
Inside Corner Detail	23
Gable Trim Detail	24
Rake Trim Detail	24
Universal Sidewall Detail	24
Universal Endwall Detail.....	24
Eave Molding Detail.....	25
Universal Gambrel Detail.....	25

	PAGE NO.
Angle Base Detail	25
Double Angle Detail	25
Drip Cap Detail	26
Base Molding Detail.....	26
Cannonball Track Cover Detail	26
National Track Cover Detail	26
Door Jamb Molding Detail	27
Mini-Angle - U-Flashing Detail	27
Post Trim Detail	27
Door Post Trim Detail.....	27
Overhead Door Trim Detail	28
Soffit Detail	28
12" Soffit Detail	28
24" Soffit Detail	28
Installation Overview	29
Residential Panel Installation	
Installing Inside Closures (Step 1)	30
Installing First Panel (Step 2).....	30
Installing Second Panel (Step 3)	31
Installing Second Eave Panel (Step 4)	31
14" Universal Ridge Detail	32
Ridge / Hip Cover Detail	32
Vented Ridge Detail	32
Gable Trim Detail	32
Eave Detail	33
Gutter Detail.....	33
Valley Detail	33
Pitch Break Detail	33
Chimney / Cricket Detail	34
Roof Penetration Detail.....	34
Care and Maintenance	35

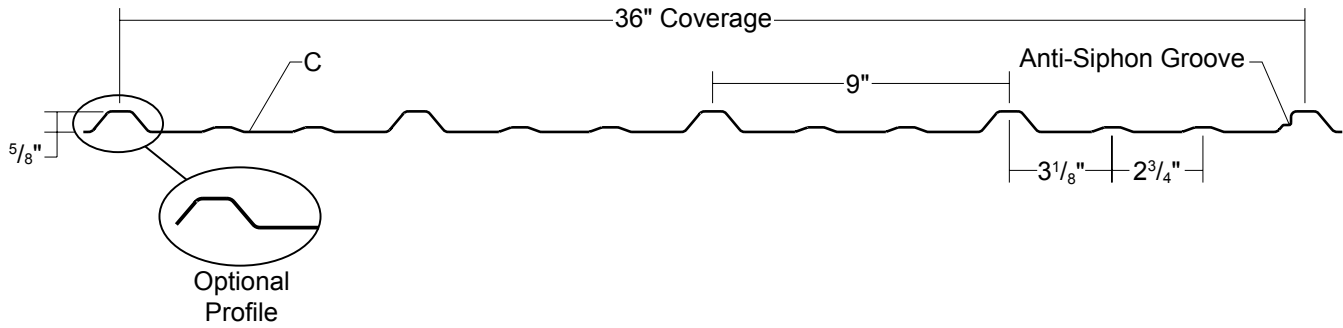

PANEL OVERVIEW

- ▶ Finishes: MS Colorfast45® and Acrylic Coated Galvalume®
- ▶ Corrosion Protection: AZ55 per ASTM A 792 for unpainted Galvalume®
AZ50 per ASTM A 792 for painted Galvalume®
G60, G90 or G100 per ASTM A 653 for Galvanized
- ▶ Gauges: 29 ga and 26 ga standard
- ▶ 36" panel coverage, 5/8" rib height
- ▶ Panel Length: Minimum: 5'; Maximum: 45' recommended
- ▶ Exposed fastened, low profile roof and wall system
- ▶ Trapezoidal rib on 9" centers
- ▶ Minimum roof slope: 3:12

TESTING AND APPROVALS

- ▶ UL 2218 Impact Resistance - Class 4
- ▶ UL 790 Fire Resistance Rating - Class A, per building code
- ▶ UL 263 Fire Resistance Rating - per assembly
- ▶ ASTM E 283 Air Leakage - 0.0076 cfm/ft² at 6.24 psf *
- ▶ ASTM E 331 Water Penetration - none at 12 psf*
- ▶ ASTM E 330 Structural Performance
- ▶ ASTM E 455 Diaphragm Capacity
- ▶ 2010 FBC Approvals - FL14645.12

* uses tape sealant and stitch screws 1' on center in side lap

FASTENING PATTERN

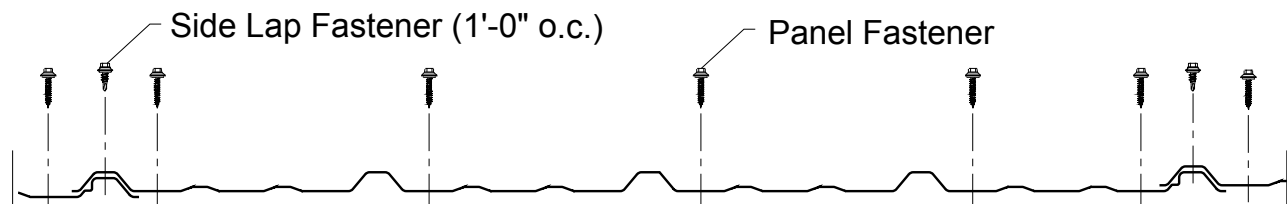

PANEL LAP DETAIL

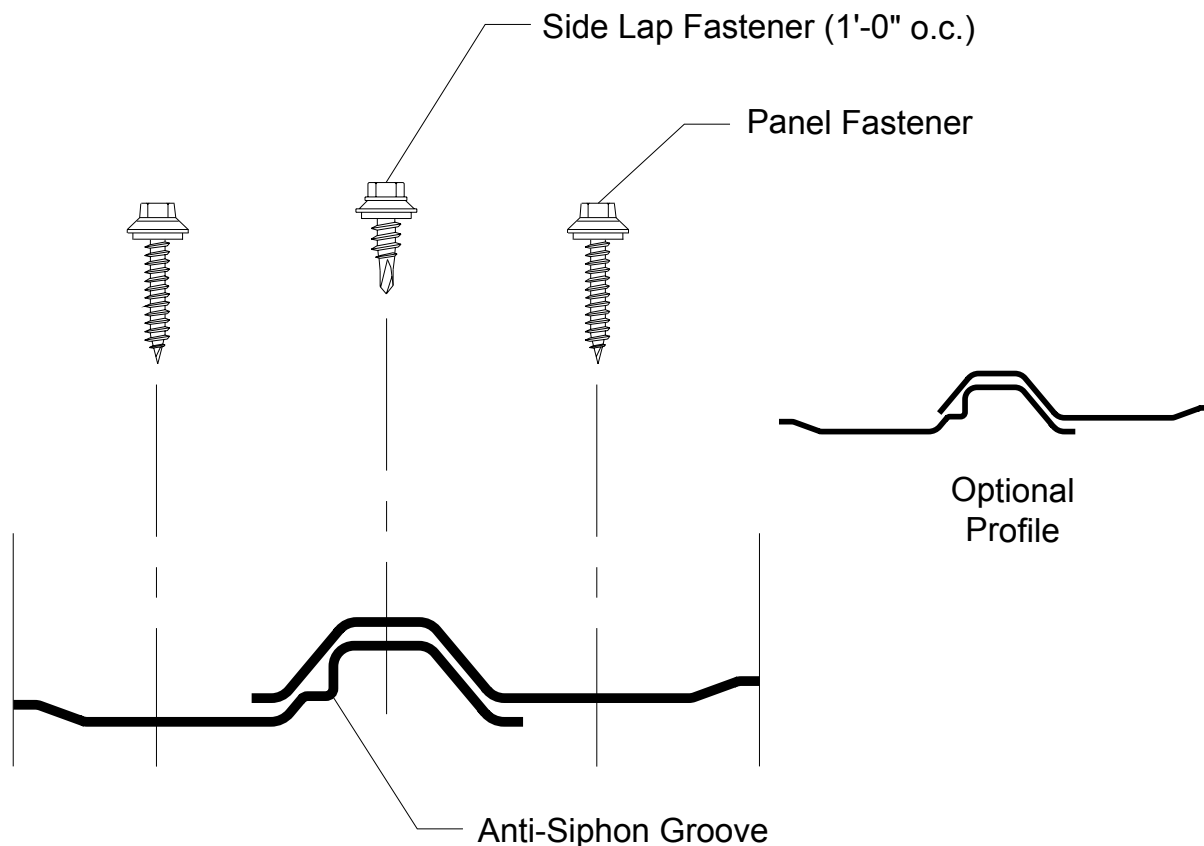

SECTION PROPERTIES

SECTION PROPERTIES								ALLOWABLE UNIFORM LOADS, psf For various fastener spacings											
Ga	Width in	Yield ksi	Weight psf	Top In Compression		Bottom In Compression		Inward Load				Outward Load							
				I _{xx} in ⁴ /ft	S _{xx} in ³ /ft	I _{xx} in ⁴ /ft	S _{xx} in ³ /ft	1.5'	2'	2.5'	3'	3.5'	4'	1.5'	2'	2.5'	3'	3.5'	4'
29	36	80	0.63	0.0067	0.0134	0.0047	0.0133	156	90	58	41	27	18	157	90	59	41	27	18
26	36	80	0.80	0.0090	0.0181	0.0063	0.0170	199	115	75	52	35	23	210	122	79	55	35	23

- Theoretical section properties have been calculated per AISI 2007 'North American Specification for the Design of Cold-Formed Steel Structural Members'. I_{xx} and S_{xx} are effective section properties for deflection and bending.
- Allowable load is calculated in accordance with AISI 2007 specifications considering bending, shear, combined bending and shear and deflection. Allowable load considers the 3 or more equal spans condition. Allowable load does not address web crippling, fasteners, support material or load testing. Panel weight is not considered.
- Deflection consideration is limited by a maximum deflection ratio of L/180 of span.
- Allowable loads do not include a 1/3 stress increase for wind.
- Diaphragm Capacity** - 306 plf average Ultimate Shear Strength using the above fastening pattern on 2x supports located 2' on center, per ASTM E 445.

USING SCREWS:

For fastening with screws, it is best to use a painted or plated screw, Type A or driller tip with a flat rubber washer. The correct screw gun is also important to the proper installation of self-drilling or self-tapping screws. A tool with the appropriate speed and torque setting (as recommended by the fastener manufacturer) will help prevent fastener thread strip-out and possible damage to the panel or its coating. Typically 40 screws should be used per square for 2' wide panels and 80 screws should be used per square for 3' wide panels.

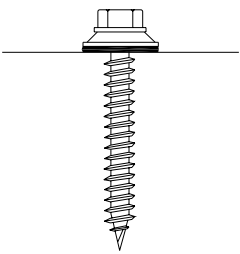
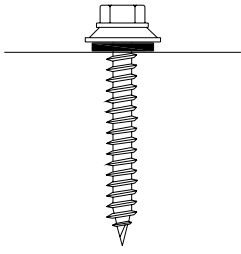
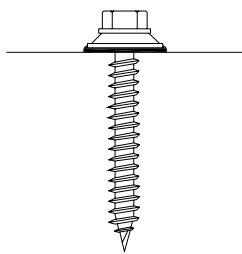
<p>CORRECT Sealing material slightly visible at edge of washer. Assembly is water tight.</p>	<p>TOO LOOSE Sealing material is not visible; not enough compression to seal.</p>	<p>TOO TIGHT Washer is deformed; sealing material pressed beyond fastener edge.</p>
		

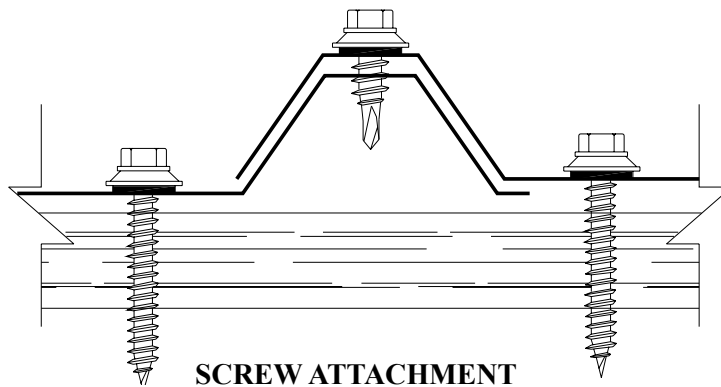

SEATING THE WASHER - Apply sufficient torque to seat the washer - do not overdrive the fastener.

TO PREVENT WOBBLING - Make sure fastener head is completely engaged in the socket. If the head does not go all the way in the socket - tap the magnet deeper into the socket to allow full head engagement. Metal chips will build up from drilling and should be removed from time to time.

PROTECT DRILL POINT - Push only hard enough on the screw gun to engage clutch. This prevents excess friction and burn out of the drill point. Correct pressure will allow screw to drill and tap without binding.

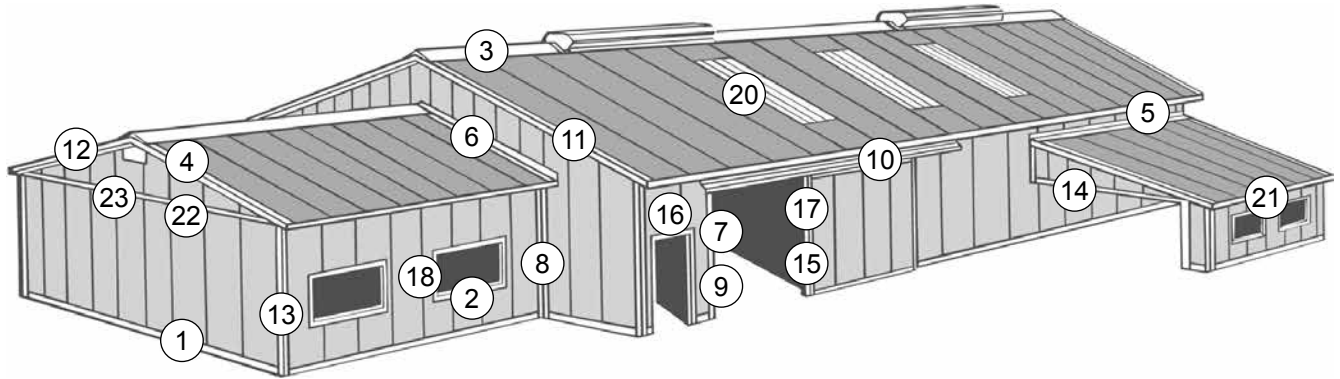

1 - BASE MOLDING

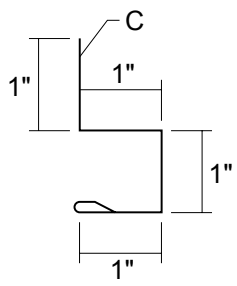

1 - ANGLE BASE

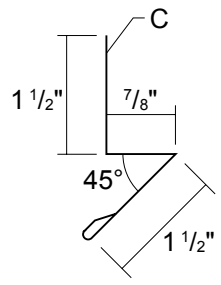

2 - J-CHANNEL

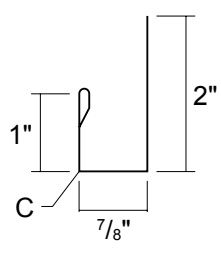

3 - 14" UNIVERSAL RIDGE

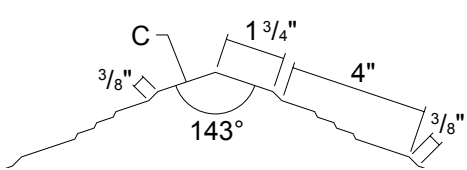

4 - SOFFIT

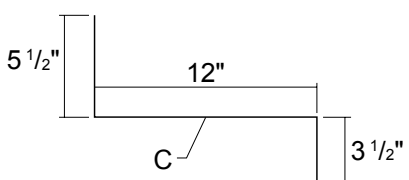

4 - 12" SOFFIT

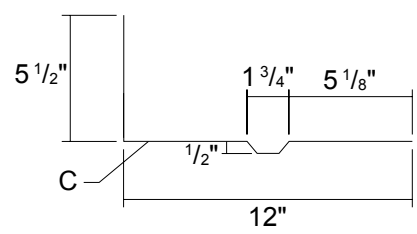

4 - 24" SOFFIT

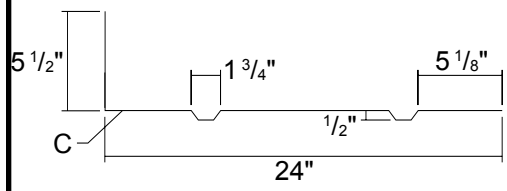

5 - UNIVERSAL ENDWALL

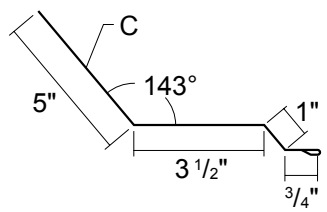

6 - UNIVERSAL SIDEWALL

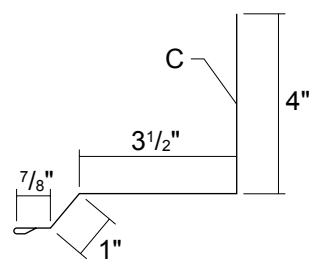

7 - MINI ANGLE

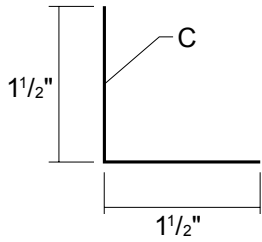

8 - INSIDE CORNER

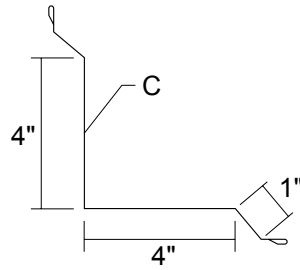

9 - POST TRIM

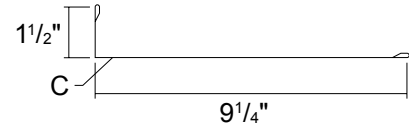

10 - NATIONAL TRACK COVER

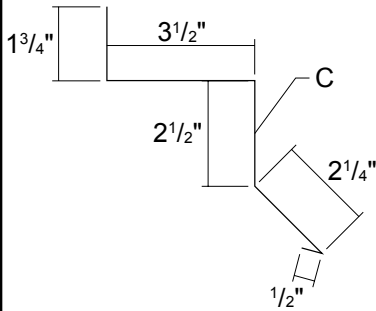

10 - TOP MOUNT TRACK COVER

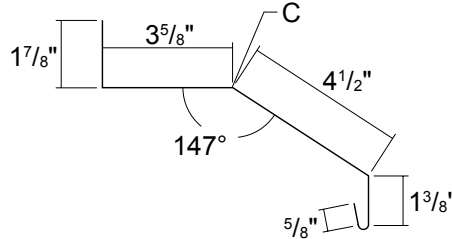

10 - CANNONBALL TRACK COVER

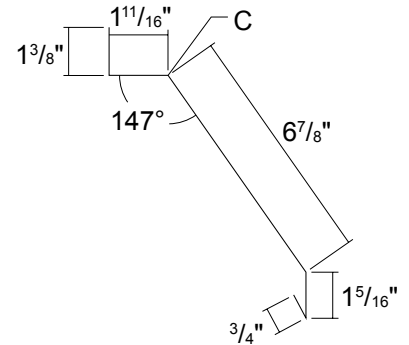

11 - GABLE TRIM

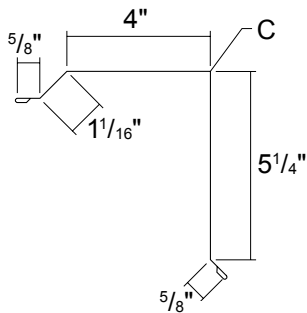

12 - RAKE TRIM

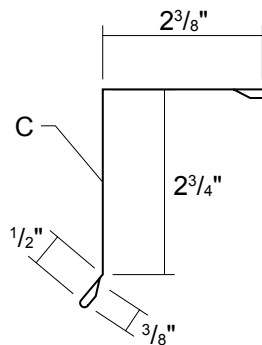

13 - OUTSIDE CORNER

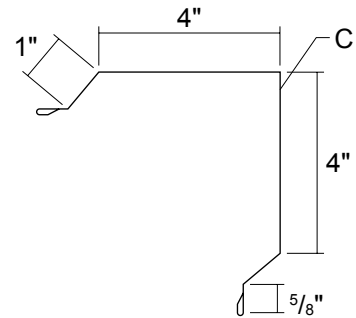

14 - OVERHEAD DOOR TRIM

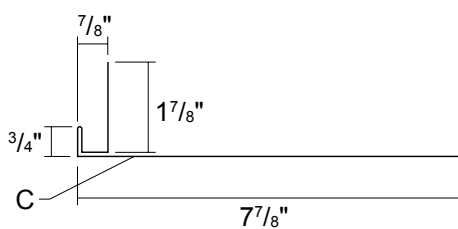

15 - DOOR JAMB

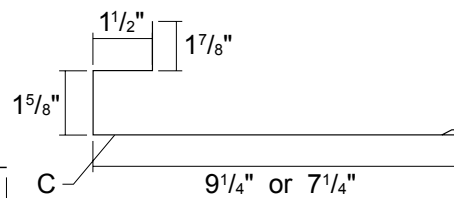

16 - DRIP CAP

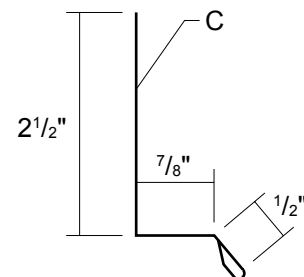

17 - DOOR POST TRIM

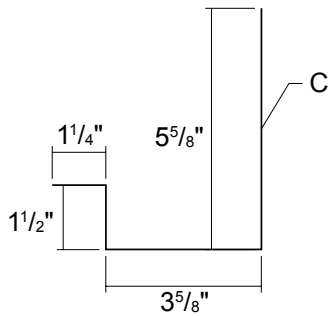

18 - FRAMING CLOSURE

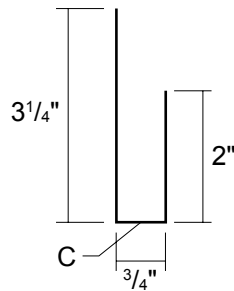

20 - TRANSLUCENT PANEL

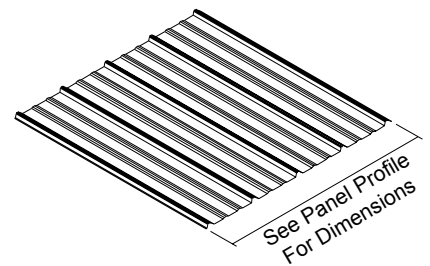

LENGTHS: 8'-0", 10'-0", 12'-0"

21 - EAVE MOLDING

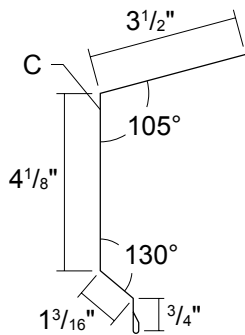

22 - DOUBLE ANGLE

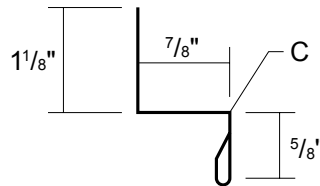

23 - WIDE Z-METAL

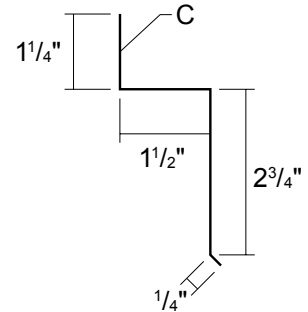

24 - UNIVERSAL GAMBREL

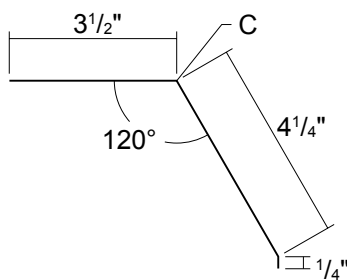

25 - RAKE / EAVE TRIM

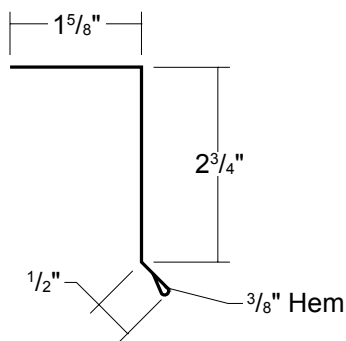

26 - 3/8" F & J-CANNEL

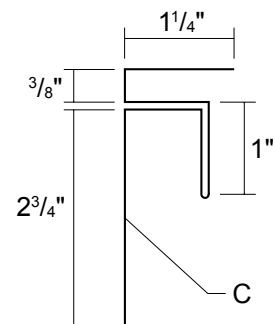

26 - 3/4" F & J-CANNEL

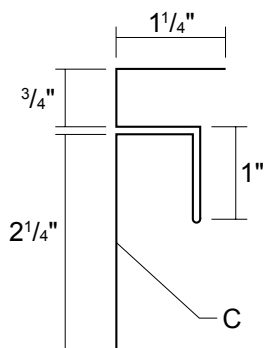

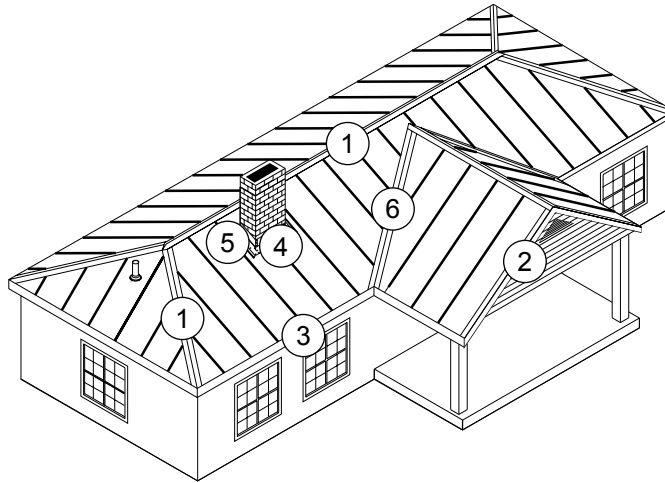

1 - RIDGE / HIP COVER

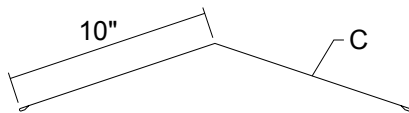

1 - 13" STEP RIDGE / HIP COVER

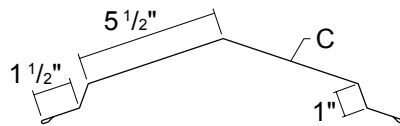

2 - GABLE TRIM

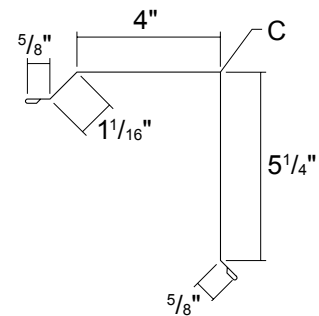

3 - EAVE

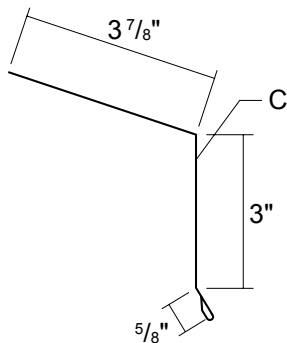

4 - UNIVERSAL ENDWALL

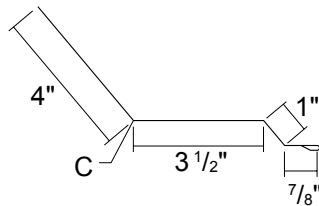

4 - PITCH BREAK

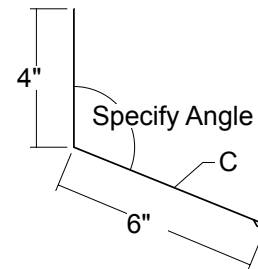

5 - UNIVERSAL SIDEWALL

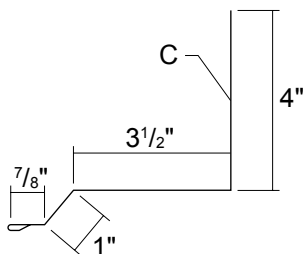

6 - VALLEY

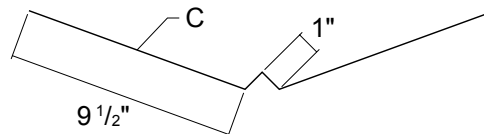

PRO-PANEL II CLOSURES

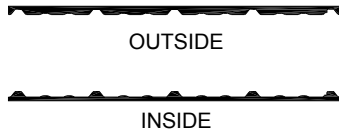

1" x 3'-0"
POLYETHYLENE FOAM

UNIVERSAL CLOSURE

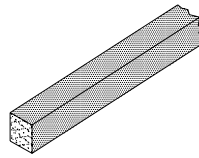

1" x 1 1/2" x 50'-0"
1" x 1 1/2" x 10'-0"

VERSA VENT



TAPE SEALANT

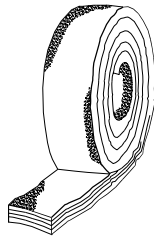

3/8" X 3/32" X 50'
SINGLE BEAD
BUTYL - GRAY

TUBE SEALANT

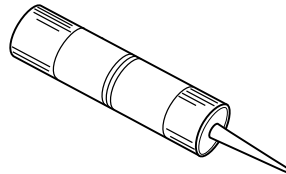

10.3 oz. CARTRIDGE
URETHANE

TOUCH-UP PAINT

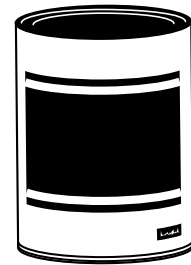

AVAILABLE IN PINTS
PVDF / MS COLORFAST45

RUBBER ROOF JACK

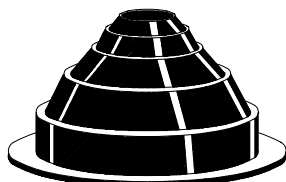

MINI (1/4" TO 1 1/8" O.D. PIPE)
#2 (1 3/4" TO 3" O.D. PIPE)
#4 (3" TO 6" O.D. PIPE)
#6 (6" TO 9" O.D. PIPE)
#8 (7" TO 13" O.D. PIPE)

MS-HT UNDERLAYMENT

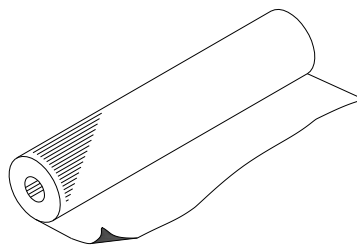

RECEIVING MATERIAL

It is the responsibility of the installer to unload material from the delivery truck. The installer shall be responsible for providing suitable equipment for unloading of material from the delivery.

After receiving material, check the condition of the material, and review the shipment against the shipping list to ensure all materials are accounted for. If damages or shortages are discovered, it should be noted on the Bill of Lading at the time of delivery. A claim should be made against the carrier as soon as possible. Metal Sales is not responsible for any damages or shortages unless they are documented in writing and presented to Metal Sales within 48 hours.

GENERAL HANDLING

Each bundle should be handled carefully to avoid being damaged. Care should be taken to prevent bending of the panel or abrasion to finish. Whenever possible, the bundle should remain crated until it is located in its place of storage. If bundles must be opened, we recommend you re-crate them before lifting. To avoid damage please lift the bundle at its center of gravity.

CAUTION

Improper loading and unloading of bundles and crates may result in bodily harm and/or material damage. Metal Sales is not responsible for bodily injuries and/or material damages resulting from improper loading and unloading.

MECHANICAL HANDLING

Forklift - A forklift may be used for panels up to 20'-0" long. Please make sure the forks are at their maximum separation. Do not transport open bundles. When transporting bundles across rough terrain, or over a longer distance, some means of supporting the panel load must be used.

Crane - A crane should be used when lifting panels with lengths greater than 20'-0". Please be sure to utilize a spreader bar to ensure the even distribution of the weight to the pick up points. As a rule when lifting panels, no more than $\frac{1}{3}$ of the length of the panel should be left unsupported. Never use wire rope because this will damage the panels.

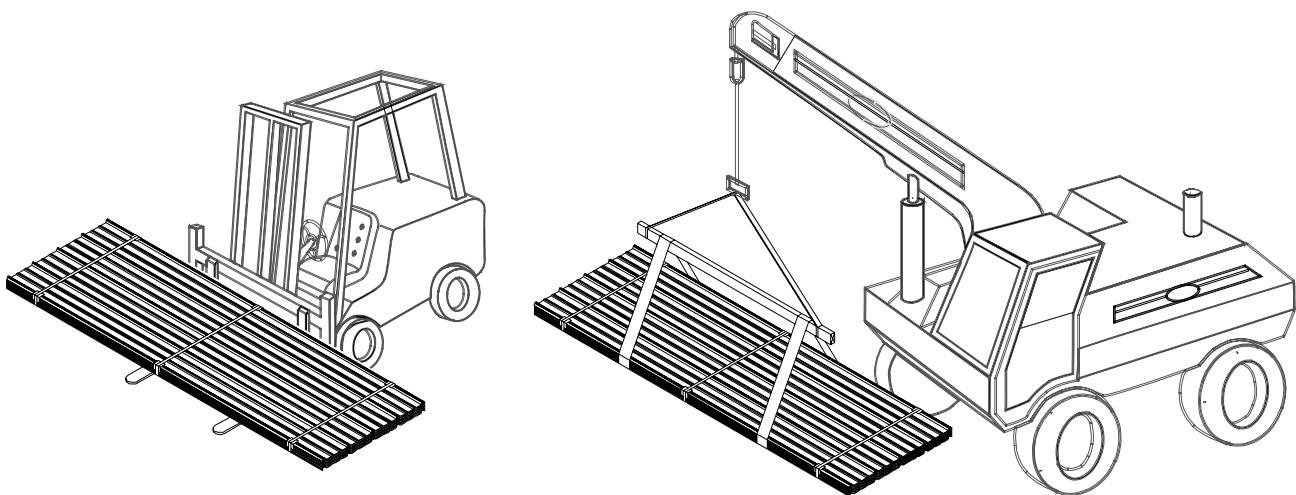

MANUAL HANDLING

When handling painted steel, care should be taken to prevent scratching of material. Clean gloves should be worn at all times to prevent a reaction with salts found on bare skin. Installers should wear rubber sole shoes to keep from scuffing material while walking on the roof.

Handling of individual panels should be done carefully and properly to avoid bending or damaging. Panels should be carried by grasping the edge of the panel so that the panel is vertical to the ground. The panel should not be carried horizontal to the ground as this could cause the panel to buckle or bend in the center.

Normally, individual panels can be handled by people placed every 6'-0" to 8'-0" along the length of the panel.

CORRECT

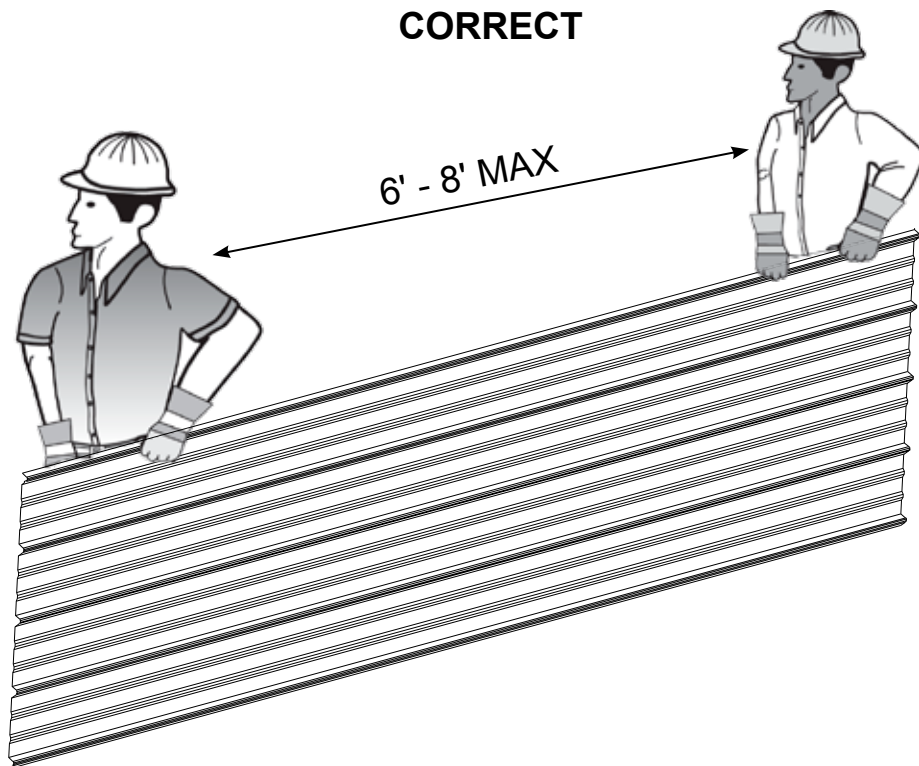

INCORRECT

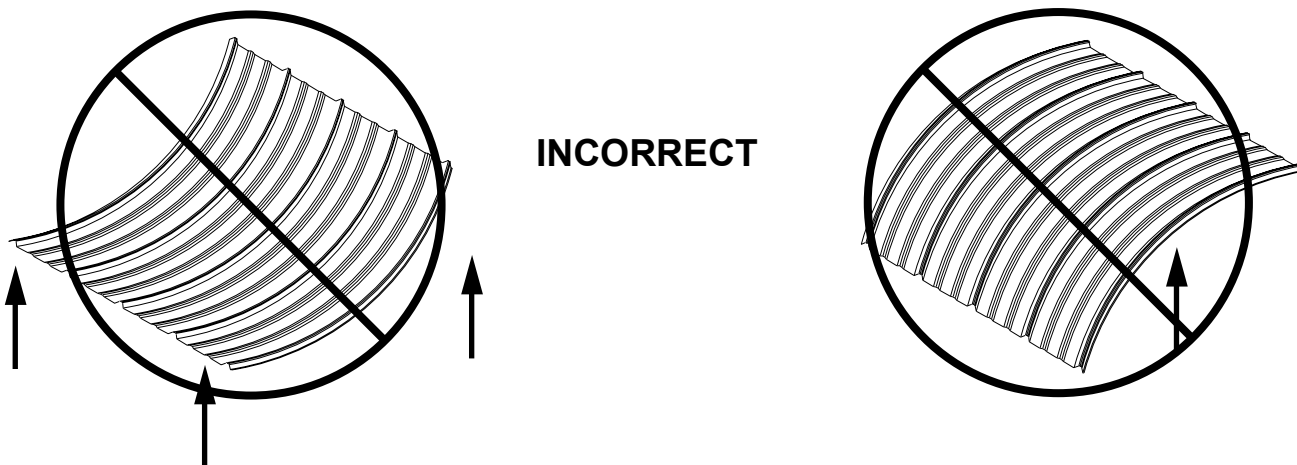

GENERAL

Please inspect panels for moisture accumulation. If moisture has formed, the panels should be unbundled, wiped dry, and allowed to dry completely. Once dry, carefully re-stack the panels and loosely recover allowing for ample air circulation.

Bundled sheets should be stored high enough off of the ground to allow for air circulation and prevent contact with accumulating water. Elevate one end of the bundle to allow any moisture to run off the panels. Metal Sales recommends covering the bundle with a tarpaulin. Do not use tight fitting plastic-type tarpaulins as panel bundle covers. While they may provide protection from heavy downpours, they can also retard necessary ventilation and trap heat and moisture that may accelerate metal corrosion. If panels are to be stored in possible bad weather, we suggest they be stored inside. Extended storage of panels in a bundle is not recommended. **Under no circumstances should the panels be stored near or come in contact with salt water, corrosive chemicals, ash, or fumes generated or released inside the building or nearby plants, foundries, plating works, kilns, fertilizer, and wet or green lumber.**

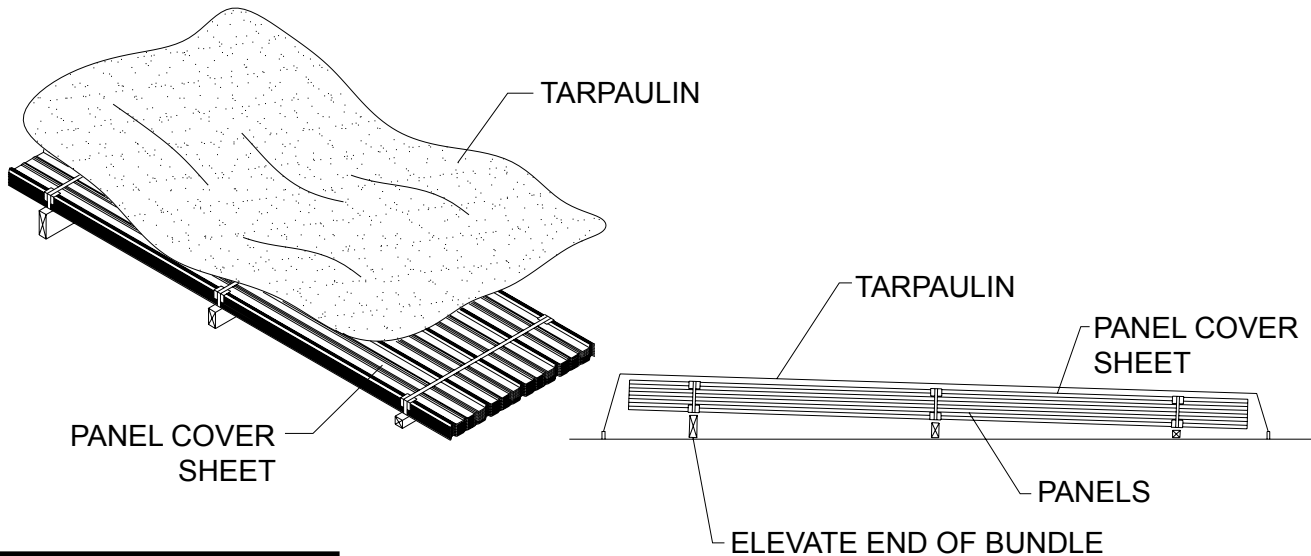

FOOT TRAFFIC

Care of metal panels and flashings must be exercised throughout erection. Foot traffic can cause distortion of panel and damage to finish. Traffic over the installed system must be kept to an absolute minimum. Installers should wear rubber sole shoes to keep from scuffing material while walking on the roof.

When walking on the roof panels is unavoidable, walk only in the flats of the panel. Walking on the ribs can cause damage to the panels.

REQUIRED TOOLS

Standard required tools for field installation include:

- Screw Guns
- Magnetic Bits
- Metal Nibbler or Shear
- Tin Snips
- Tape Measure
- Hammer
- Chalk Line
- Drill with bits
- Pop Rivet Gun
- Safety Goggles
- Gloves
- Ear Plugs
- Fall Protection

GENERAL

Metal Sales' panels are designed to be installed over open framing and/or directly over a wood substrate (minimum 5/8") with 30# felt moisture barrier (or an Ice and Water Shield when required by Local Building Codes).

Always check with local building codes prior to all installations for any additional requirements that may be specific to your area.

Galvanized and Galvalume panels should not be in contact with, or subject to, water runoff from copper, lead, or uncoated steel materials.

Condensate water from air conditioning units typically contains dissolved copper. This condensate should be discharged through a plastic pipe extended beyond the edge of the roof.

CONDITION OF SUBSTRUCTURE

The roof should be inspected for any trapped moisture or structural damage such as bowing or sagging rafters and warped or loose roof purlins or solid decking. These areas should be repaired prior to installing new metal panels.

Prior to installation, make sure there are no nails or fasteners protruding from the roof framing or wood substrate which could damage the panels and impede the installation process.

When installed, panel distortion may occur if not applied over properly aligned and uniform substructure.

Whether installing over new or existing roof, the installer should check the roof deck for squareness before installing panels. Several methods can be used to verify squareness of the structure for proper installation of the panels.

METHOD "A" - One method for checking the roof for squareness is to measure diagonally across one slope of the roof from similar points at the ridge and eave and obtain the same dimension.

METHOD "B" - The 3-4-5 triangle system may also be used. To use this system, measure a point from the corner along the edge of the roof at a module of three (3). Measure a point from the same corner along another edge at a module of four (4). By measuring diagonally between the two points established, the dimension should be exactly a module of five (5) to have a square corner. Multiple uses of this system may be required to determine building squareness. If the endwall cannot be made square, the roof system cannot be installed as shown in these instructions.

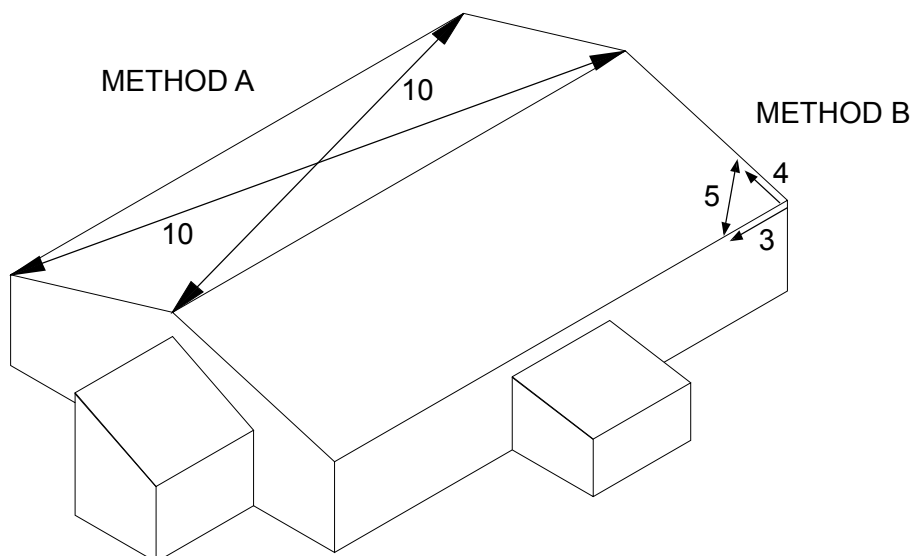

FIELD CUTTING

Tin snips or a "nibbler" type electric tool are recommended for field cutting metal panels. Cutting the steel generates slivers or metal chips. These slivers and metal chips must be immediately removed from the panels because they will damage the finish and shorten the life of the product.

One method of preventing this problem is to flip the panels over when cutting. This allows the slivers and metal chips to be brushed from the back side and avoids damaging the paint on the top side of the panels.

When cutting metal panels and flashings, goggles must be worn for eye protection.

CAUTION
 All product surfaces should be free of debris at all times. Installed surfaces should be wiped clean at the end of each work period. Never cut panels over metal surfaces. Metal shavings will rust on the surface, voiding the warranty.

TOUCH-UP PAINT

All painted panels and flashings have a factory applied baked on finish. Handling and installing panels may result in some small scratches or nicks to the paint finish. Touch-up paint is available in matching colors from Metal Sales. It is recommended that a small brush be used to apply touch-up paint to those areas that are in need of repair. Touch-up paint does not have the superior chalk and fade resistance of the factory applied paint finish and will normally discolor at an accelerated rate. Aerosol paint should not be used because of the overspray that may occur.

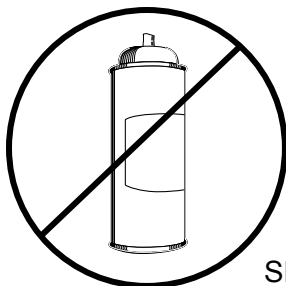

SPRAY PAINT

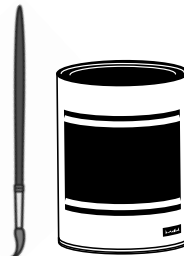

TOUCH-UP PAINT

VENTILATION

Proper design and installation of vapor barriers and ventilation systems are important to prevent condensation and the resulting problems of moisture damage and loss of insulation efficiency.

Condensation occurs when moisture laden air comes in contact with a surface temperature equal to or below the dew point of the air. This phenomenon creates problems that are not unique with metal buildings; these problems are common to all types of construction.

The underside of the metal roof on a typical metal building (no attic) should be protected from condensation by insulating with a faced insulation. This should reduce the potential of condensation forming on the underside of the panels. On buildings that have an attic space or are being retrofitted with a metal roofing system, vents should be placed at both the eave and peak of the roof in order to prevent a buildup of moisture (humidity) in the attic space.

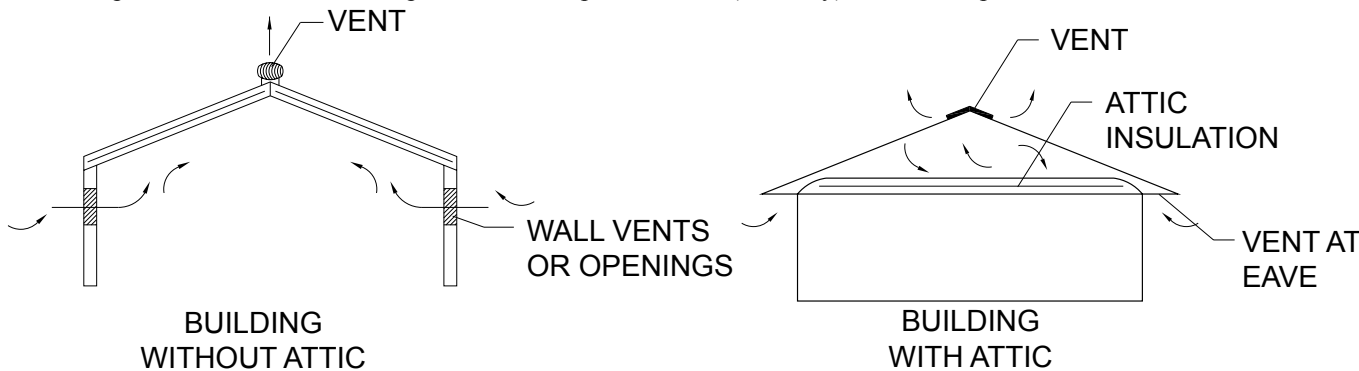

PRO-PANEL II® FASTENER SELECTION GUIDE

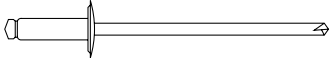
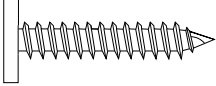
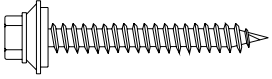
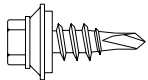

POP RIVET	SIZE	TYPE	FINISH	APPLICATION
	1/8" x 3/16"	A	Unpainted	Flashing to Panel, Flashing to Flashing
	1/8" x 3/16"	A	Painted	Flashing to Panel, Flashing to Flashing
PANCAKE HEAD WOODSCREW	SIZE	TYPE	FINISH	APPLICATION
	#10-12 x 1"	A	Plated	Panel or Flashing to wood substructure
WOODSCREW	SIZE	TYPE	FINISH	APPLICATION
	#9-15 x 1"	A	Painted	Panel or Flashing to wood substructure
	#9-15 x 1 1/2"	A	Painted	
	#9-15 x 2"	A	Painted	
STITCH SCREW	SIZE	TYPE	FINISH	APPLICATION
	#1/4 - 14 x 7/8"	Stitch	Painted	Flashing to Panel, Flashing to Flashing, Panel Sidelap

PANEL

Length - Minimum factory cut length is 5'-0" on panels. Panels over 45'-0" require additional consideration in packaging, shipping, and erection. Please consult Metal Sales for recommendations.

There are two critical measurements involving metal panels: the length of panel overhang required at the eave, and the peak end. In each case a certain measurement is required. Check each measurement to ensure panel placement gives you the distance required at the eave, and peak condition. In most cases any variance can be taken out at the eave or peak ends.

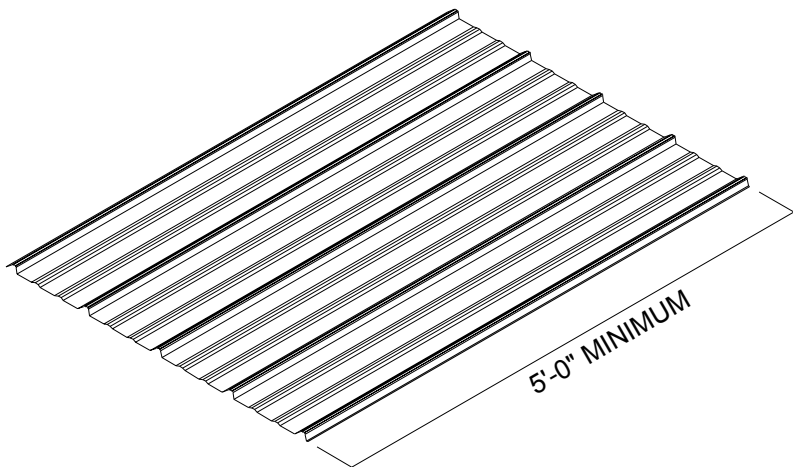

INSTALLATION OVERVIEW

- ◆ As shown below with the number designations, install panel against the prevailing wind. Installing Wall Panels first then Roof Panels
- ◆ To minimize corrosion, siding panels should not be installed all the way to the ground.
- ◆ Siding panels should lap over the foundations or splash boards at least three inches.
- ◆ Make sure panels are square and plumb, to assure straight and proper alignment of the entire row of panels.
- ◆ For areas with high wind considerations, closer fastener spacing may be required.
- ◆ It is necessary to attach a temporary guide to the foundation to use as an alignment guide when installing siding panels.
- ◆ Siphon groove side of panel must be overlapped with the non siphon groove side of the adjacent panel (if applicable) .

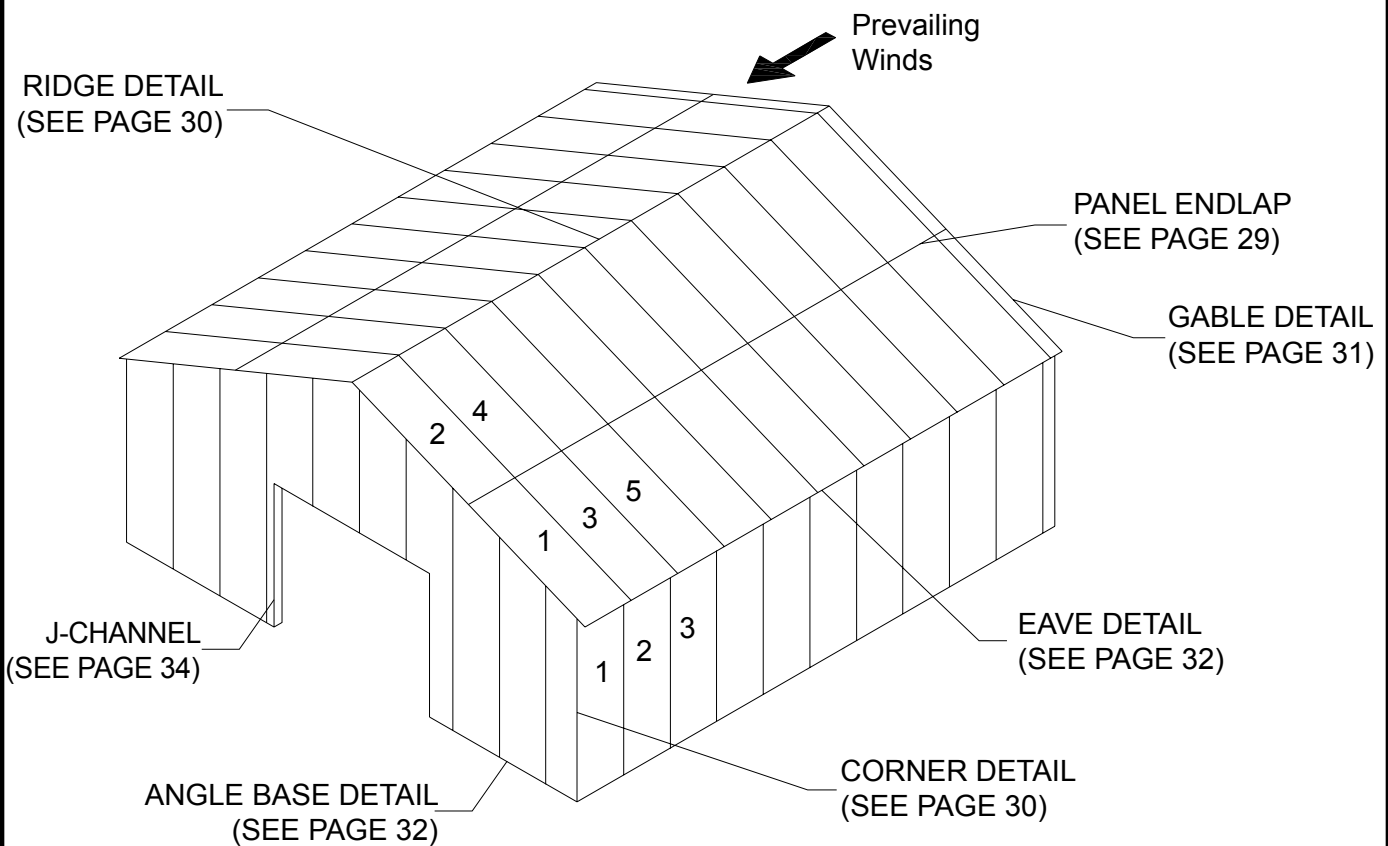

NOTE: -Eave Molding, Gutter and Valley Flashings must first be installed before panel installation can begin.
 -Panels can be installed going from either left to right or right to left / looking from eave to peak.

INSTALLING INSIDE CLOSURES

STEP 1

1. Apply a row of Tape Sealant across the top leg of the Eave Molding along the width of the building.
2. Align and place Inside Closures over the Tape Sealant. It is critical that Inside Closures are square to building as this will control the alignment of the panels. (See page 24 to check building square).
3. Apply a row of Tape Sealant across the top of the Inside Closure (Not shown for clarity).

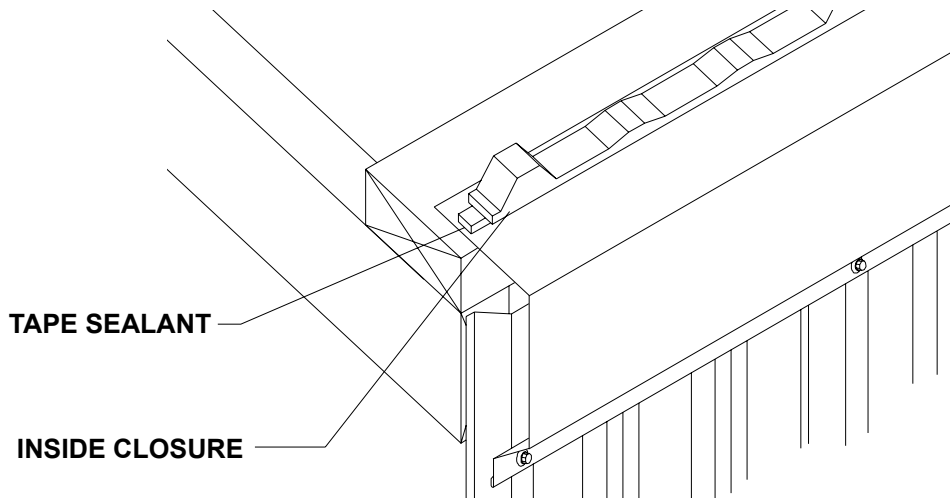

INSTALLING FIRST PANEL

STEP 2

1. Install the first panel over the Inside Closure allowing desired overhang. Make sure the panel is square to the eave and rake.
2. Fasten through panel, closure, and sealants into decking with appropriate amount of fasteners to meet local building code. (See fastening patterns on pages 13 and 14). Fasteners must penetrate closure and sealant.
3. After securing panel at eave, repeat the fastening pattern at all panel support locations.

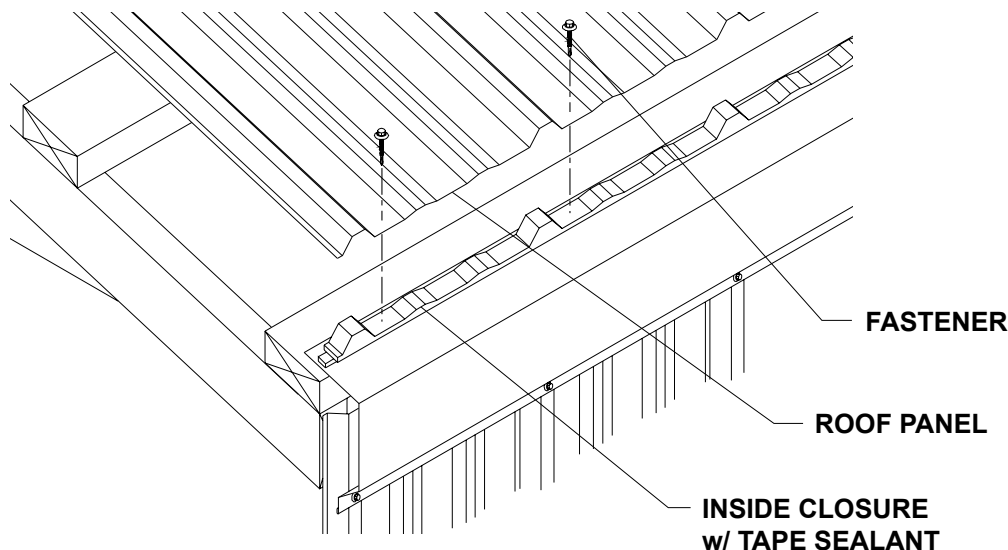

INSTALLING ENDLAP PANEL (IF REQUIRED)

STEP 3

1. Apply a row of Tape Sealant across and over the ribs of the eave panel about 3" from panel end.
2. Install the ridge panel over the eave panel and Tape Sealant with a 6" Endlap. **Fasten through both panels and Tape Sealant into support with appropriate amount of fasteners to meet local building code. (See fastening patterns on pages 13 and 14). Fasteners must penetrate sealant.**
3. After securing panel, repeat the fastening pattern at all panel support locations.

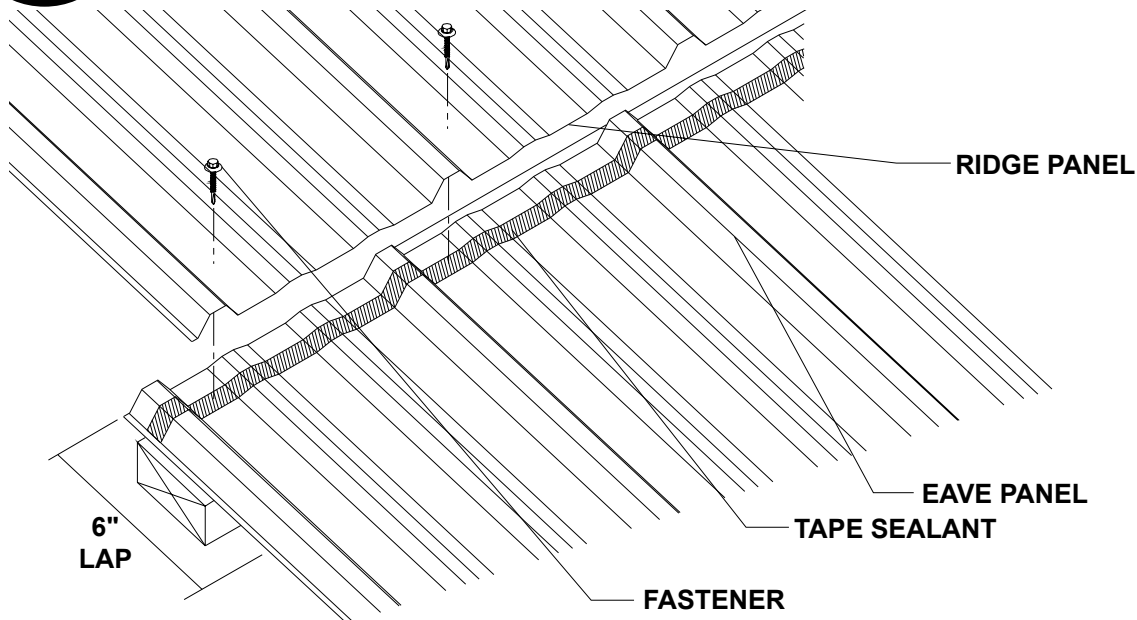

INSTALLING SIDELAP PANEL

STEP 4

1. Place the lapping seam of the second panel on top of previously installed panel so that panel ends are flush at eave (See below).
2. **Fasten through panel, closure, and Tape Sealant into support with appropriate amount of fasteners to meet local building code. (See fastening patterns on pages 13 and 14). Fasteners must penetrate closure and sealant.**
3. After securing panel, repeat the fastening pattern at all panel support locations.

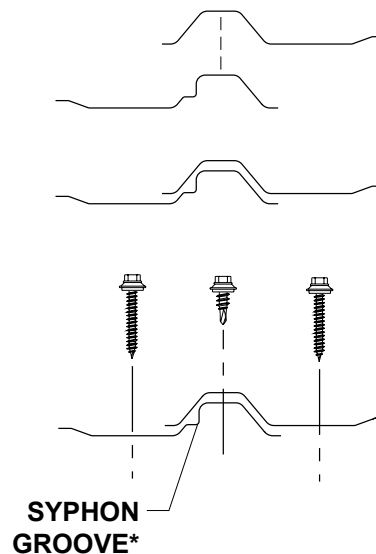
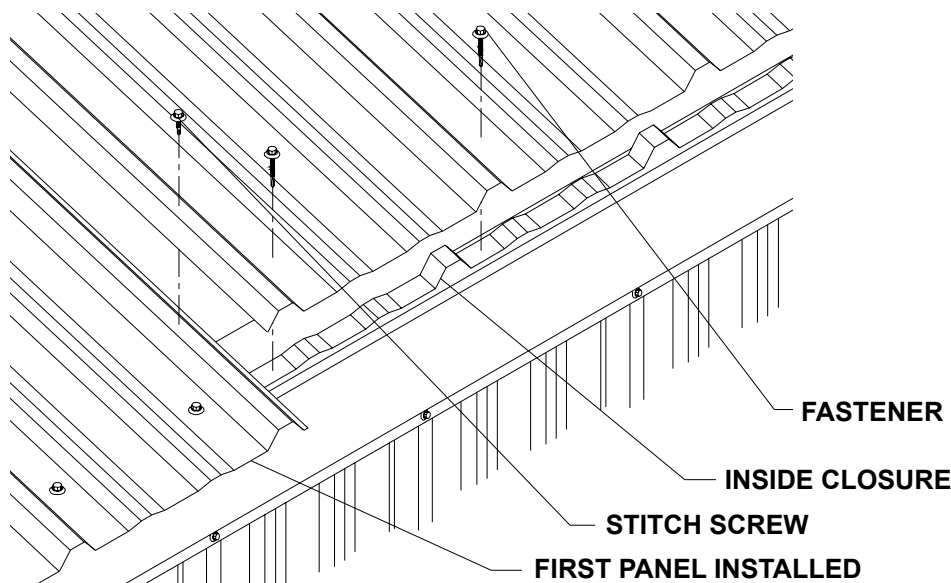

*PANELS WITHOUT A SYPHON GROOVE REQUIRE TAPE SEALANT IN THE SIDELAP

14" UNIVERSAL RIDGE DETAIL

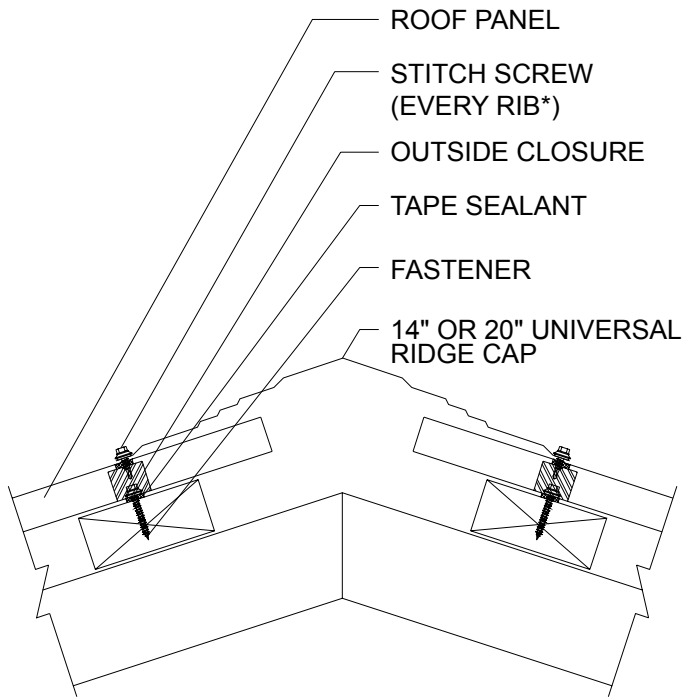

* FASTENER SPACING TO BE 8" - 12" O.C.

LOW PROFILE RIDGE VENT DETAIL

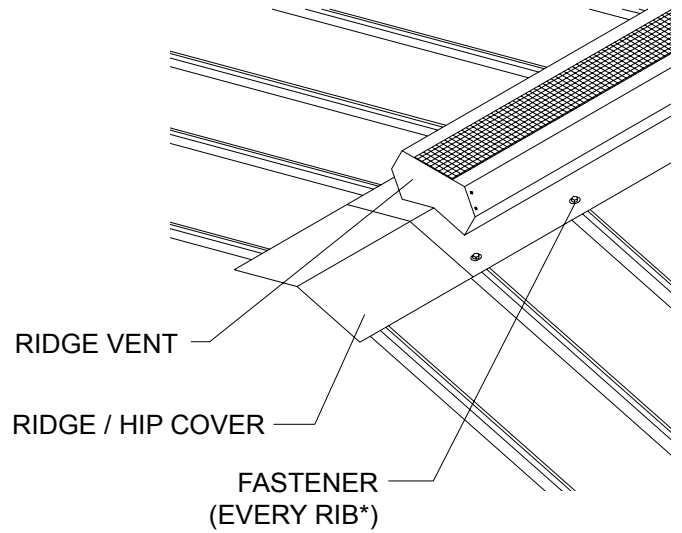

* FASTENER SPACING TO BE 8" - 12" O.C.

OUTSIDE CORNER DETAIL

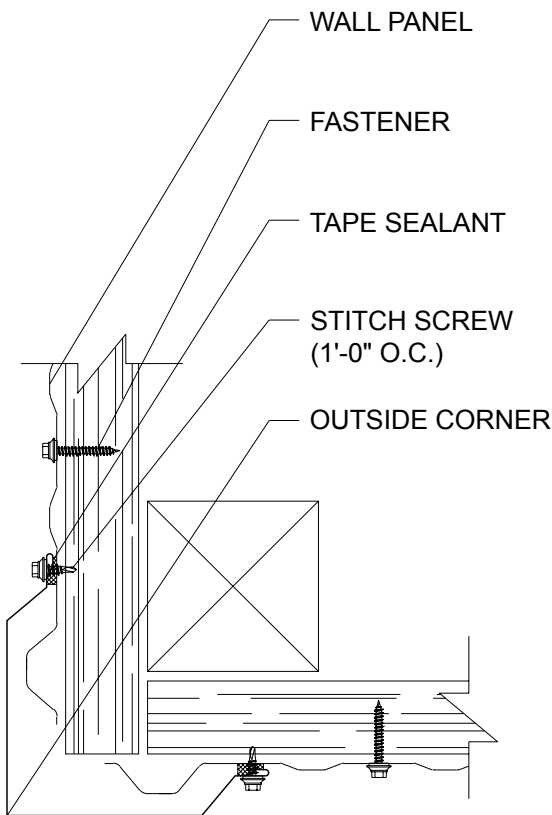

INSIDE CORNER DETAIL

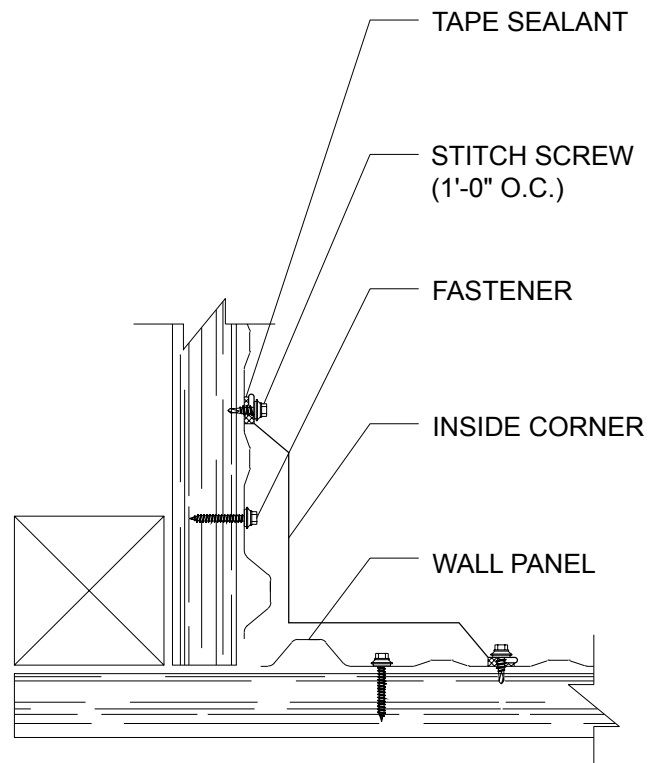

GABLE TRIM DETAIL

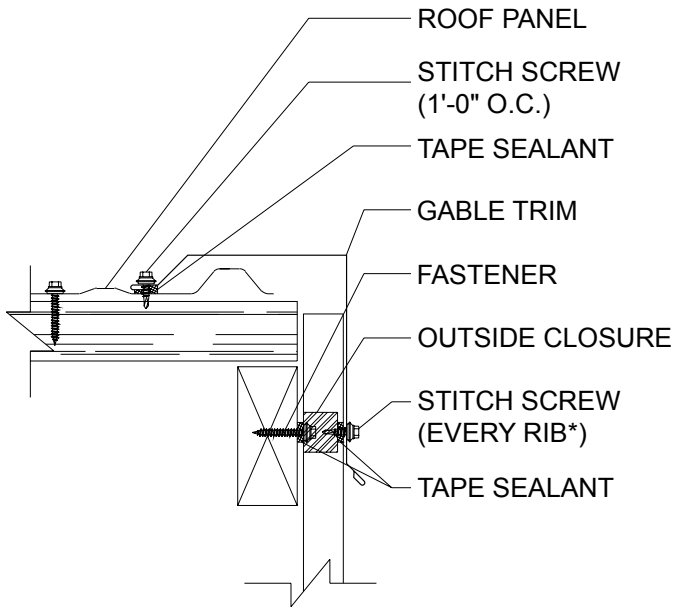

* FASTENER SPACING TO BE 8" - 12" O.C.

RAKE TRIM DETAIL

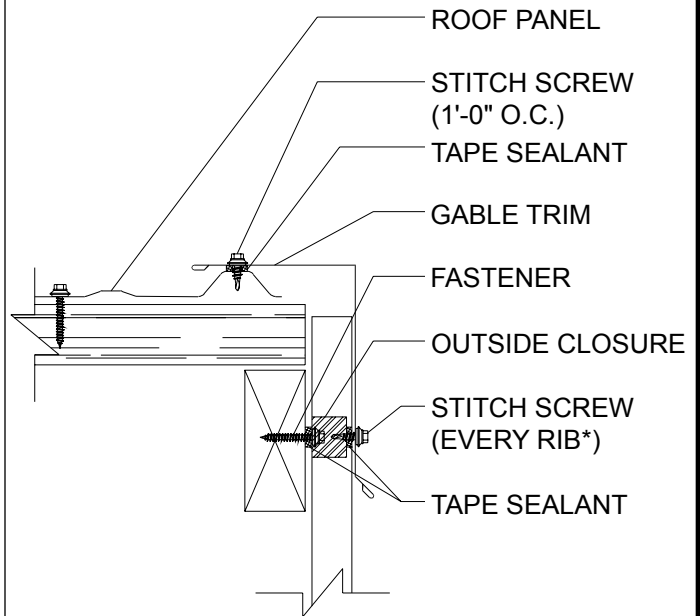

* FASTENER SPACING TO BE 8" - 12" O.C.

UNIVERSAL SIDEWALL DETAIL

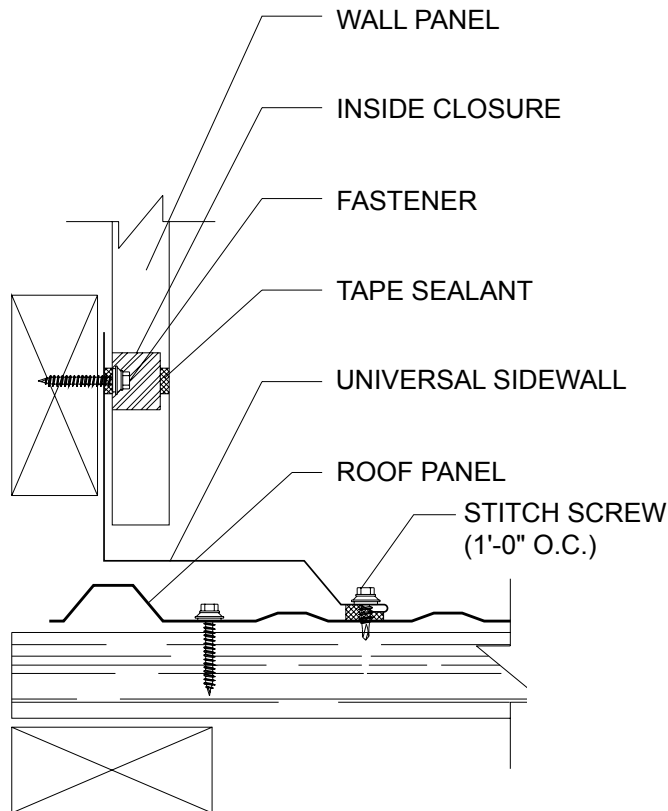

UNIVERSAL ENDWALL DETAIL

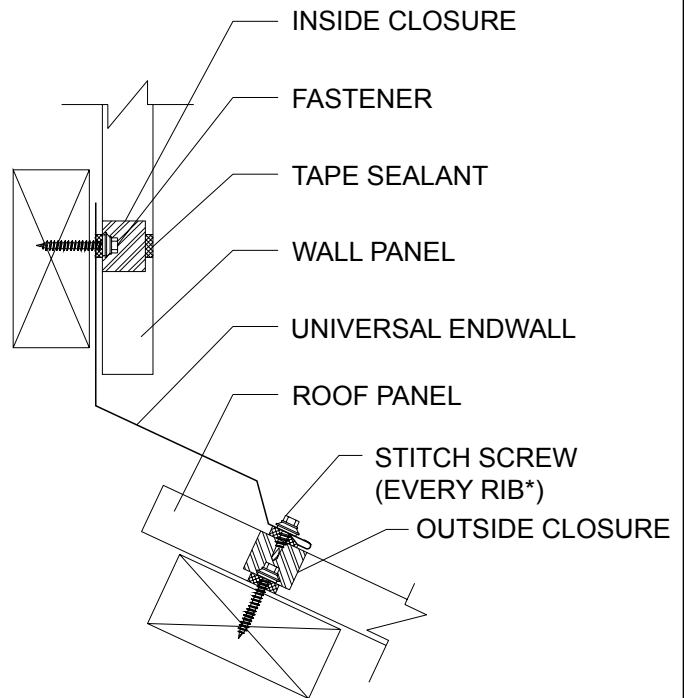

* FASTENER SPACING TO BE 8" - 12" O.C.

EAVE MOLDING DETAIL

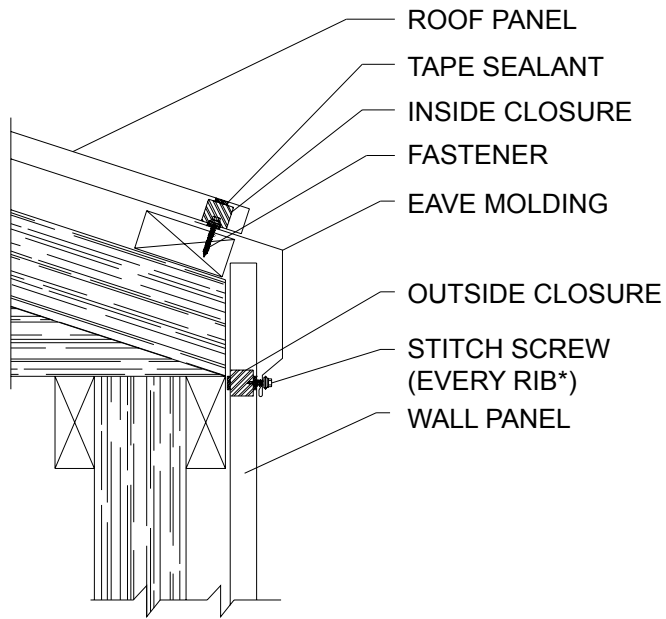

* FASTENER SPACING TO BE 8" - 12" O.C.

UNIVERSAL GAMBREL DETAIL

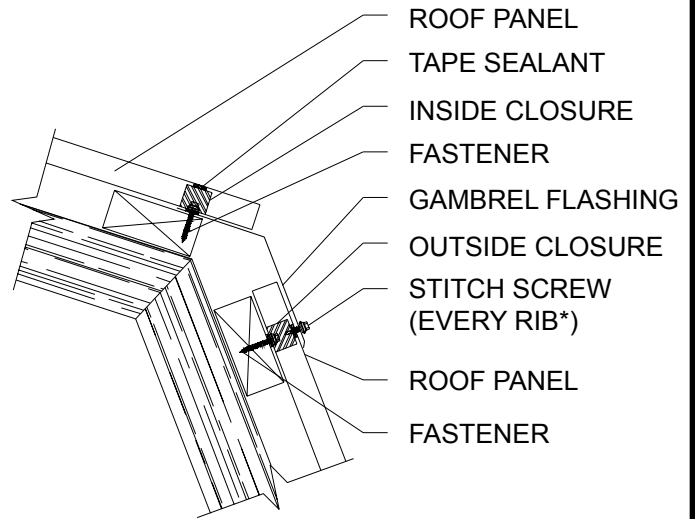

* FASTENER SPACING TO BE 8" - 12" O.C.

ANGLE BASE DETAIL

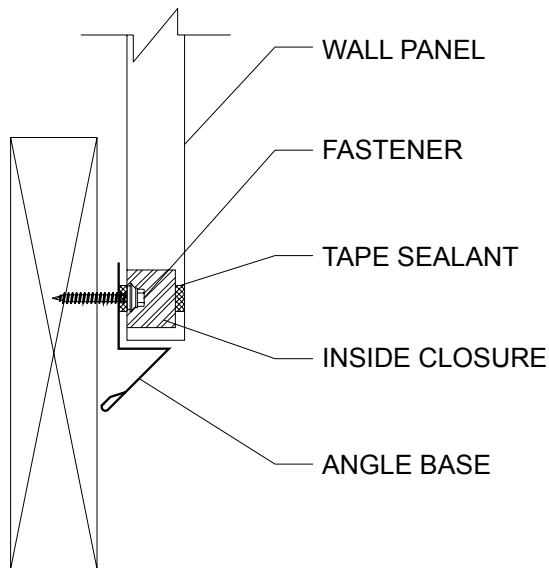

DOUBLE ANGLE DETAIL

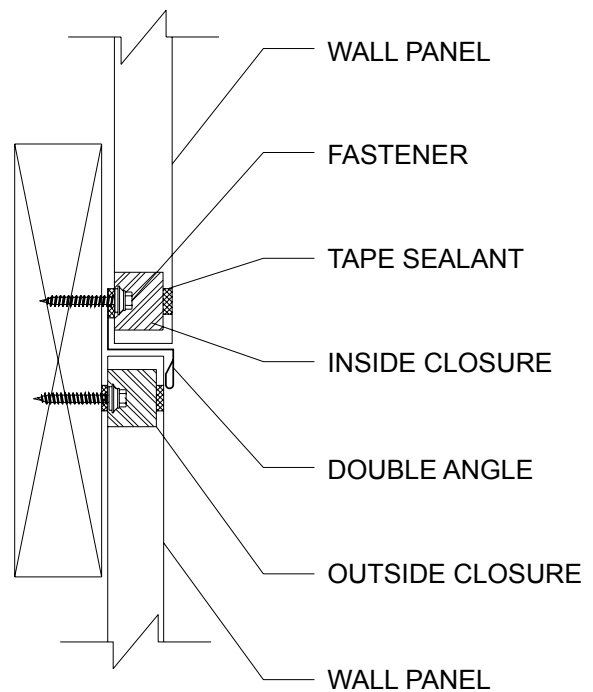

DRIP CAP DETAIL

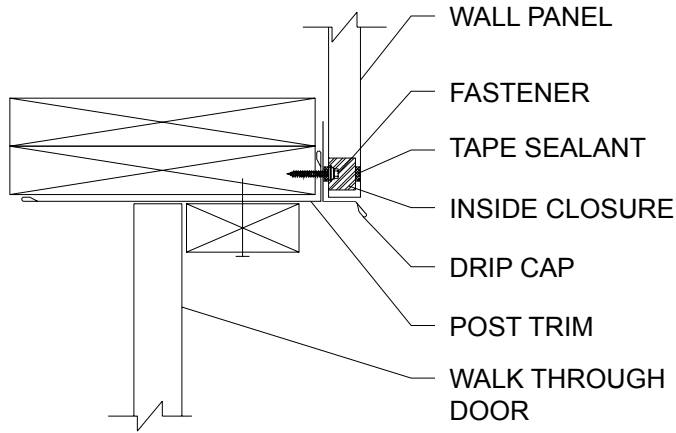

BASE MOLDING DETAIL

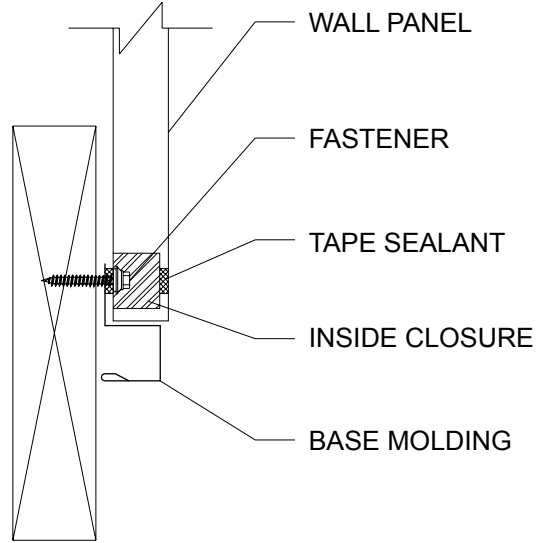

CANNONBALL TRACK COVER DETAIL

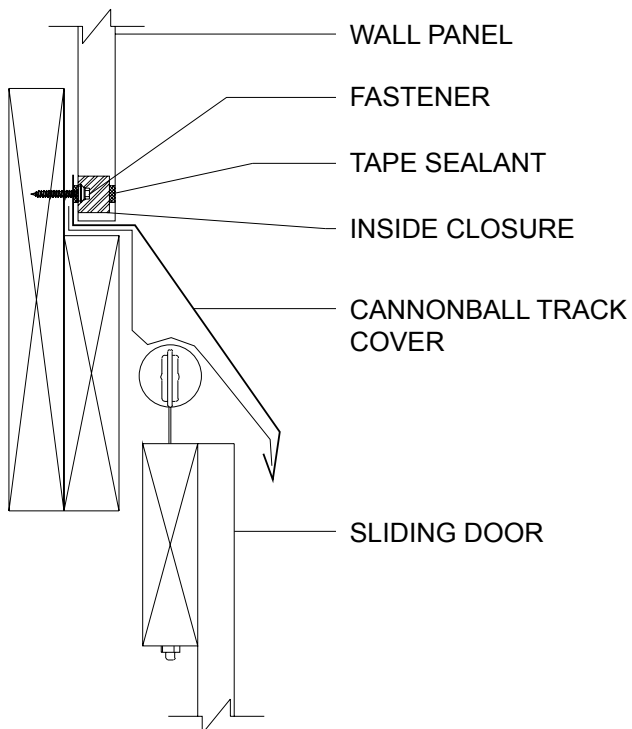

NATIONAL TRACK COVER DETAIL

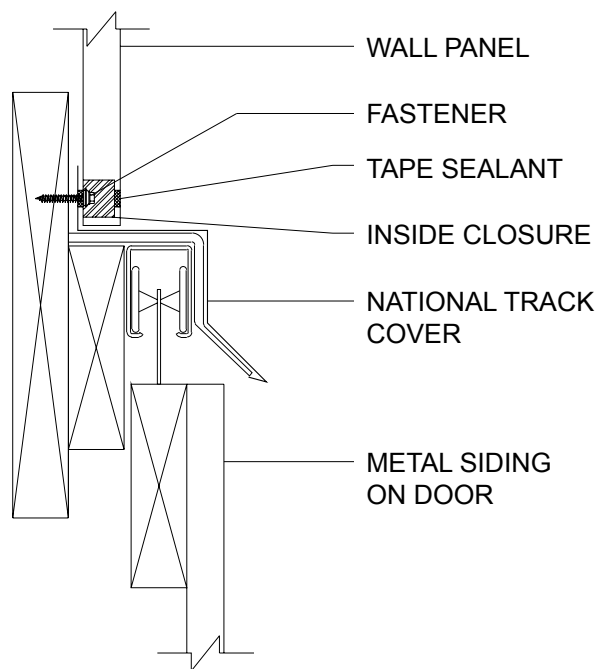

DOOR JAMB DETAIL

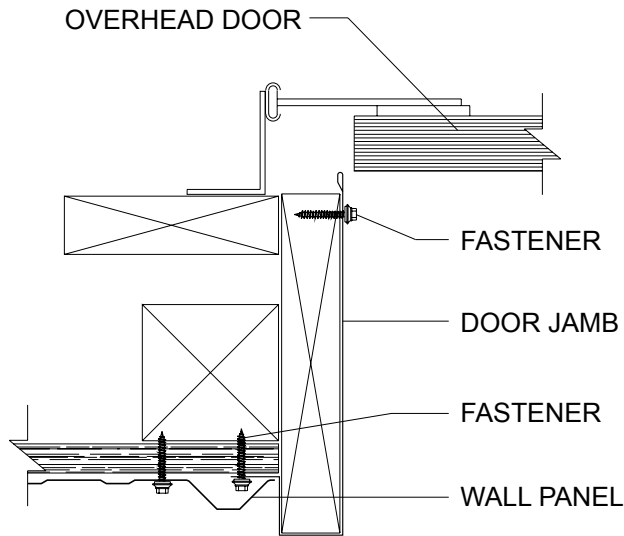

MINI-ANGLE / U-FLASHING DETAIL

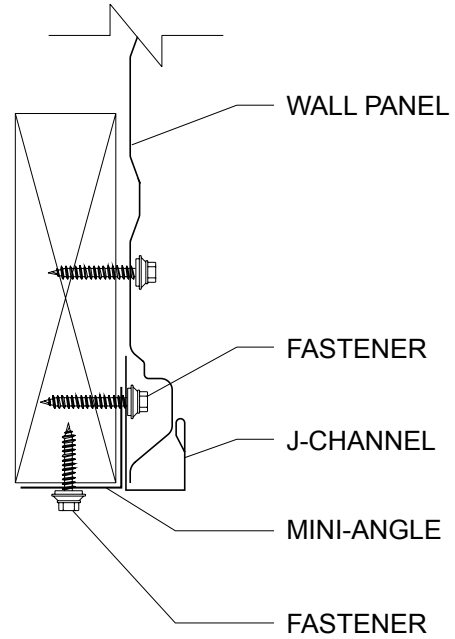

POST TRIM DETAIL

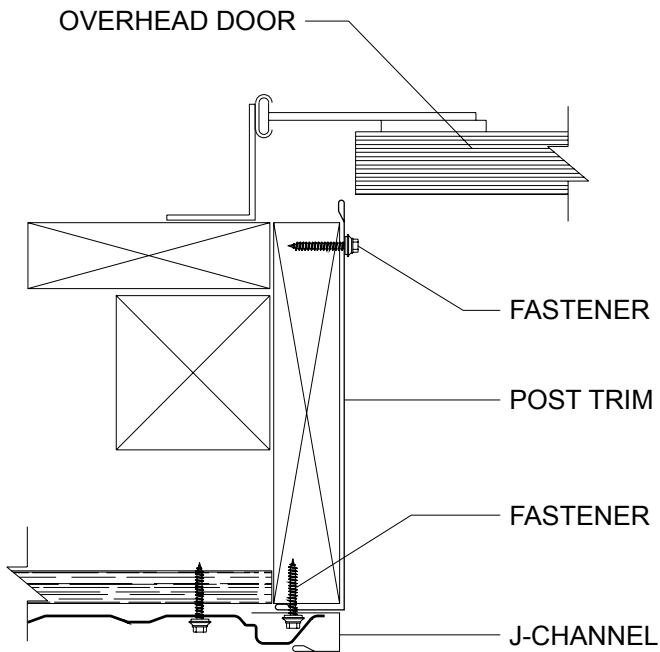

DOOR POST TRIM DETAIL

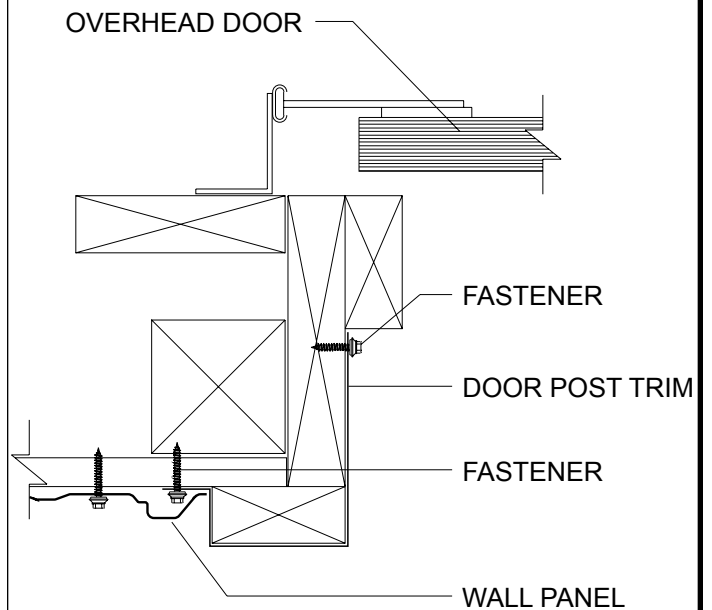

OVERHEAD DOOR TRIM DETAIL

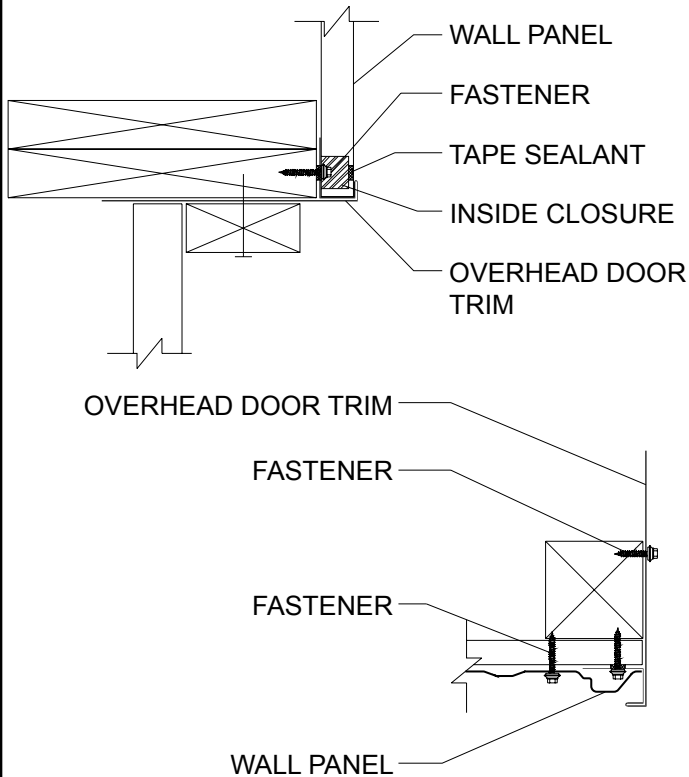

SOFFIT DETAIL

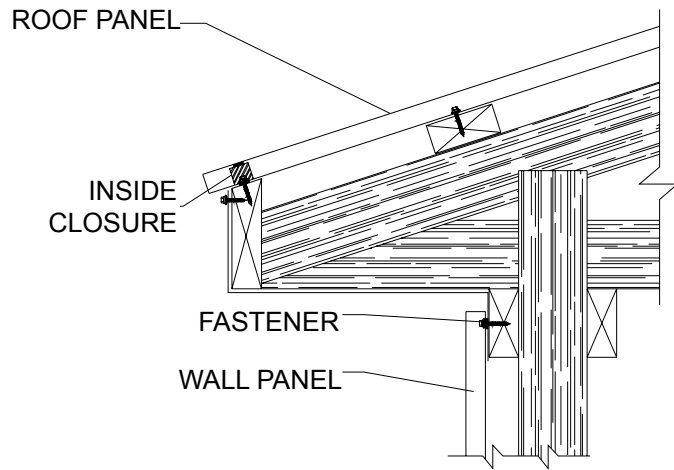

* FASTENER SPACING TO BE 8" - 12" O.C.

12" SOFFIT DETAIL

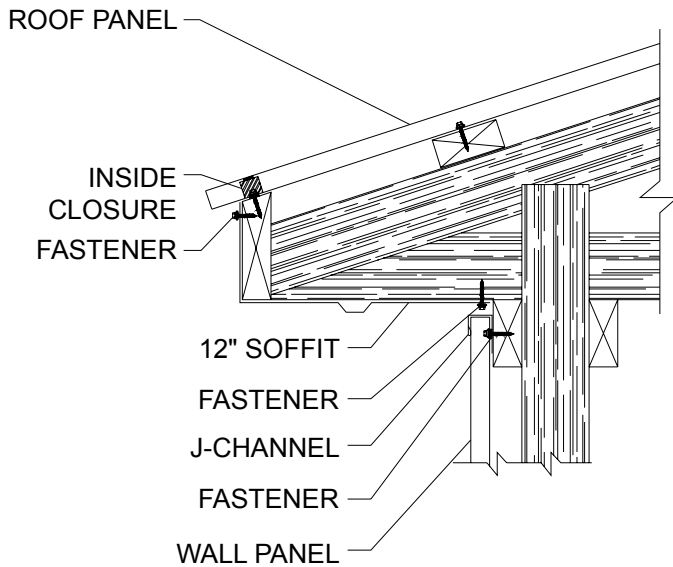

24" SOFFIT DETAIL

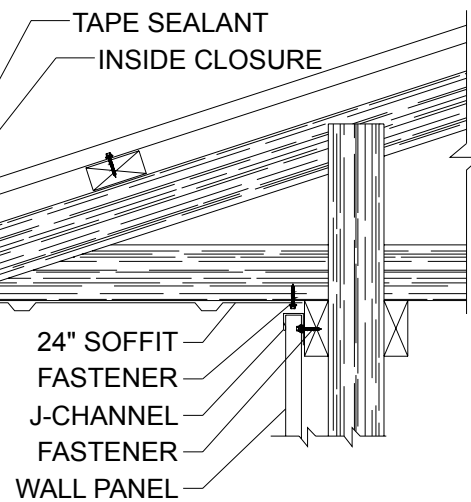

INSTALLATION OVERVIEW

- ◆ As shown below with the number designations, install panel against the prevailing wind.
- ◆ Make sure panels are square and plumb, to assure straight and proper alignment of the entire row of panels.
- ◆ For areas with high wind considerations, closer fastener spacing may be required.
- ◆ It is necessary to attach a temporary guide to the foundation to use as an alignment guide when installing siding panels.
- ◆ Siphon groove side of panel must be overlapped with the non-siphon groove side of the adjacent panel (if applicable).

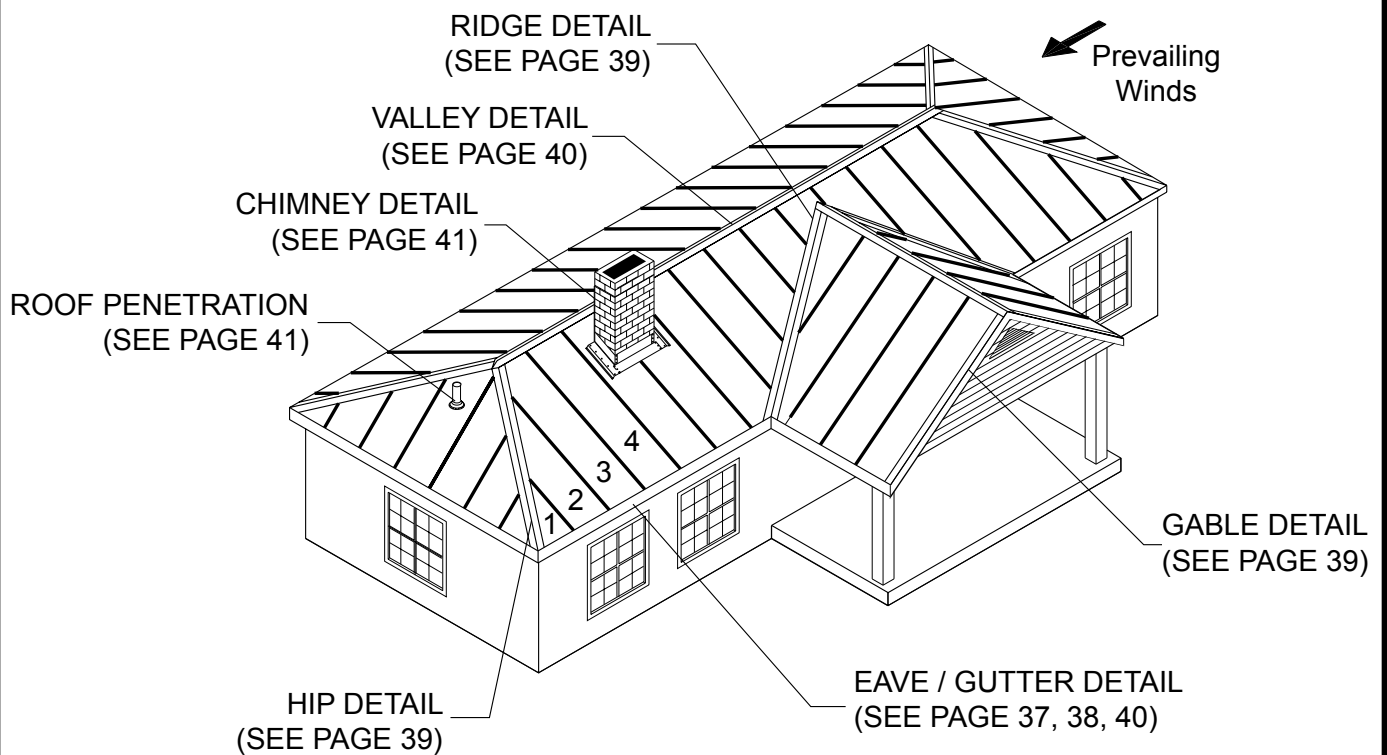

NOTE: -Eave Molding, Gutter and Valley Flashings must first be installed before panel installation can begin.
 -Panels can be installed going from either left to right or right to left / looking from eave to peak.

INSTALLING INSIDE CLOSURES

STEP 1

1. Apply a row of Tape Sealant across the top leg of the Eave Molding along the width of the building.
2. Align and place Inside Closures over the Tape Sealant. It is critical that Inside Closures are square to building as this will control the alignment of the panels. (See page 24 to check building square).
3. Apply a row of Tape Sealant across the top of the Inside Closure (Not shown for clarity).

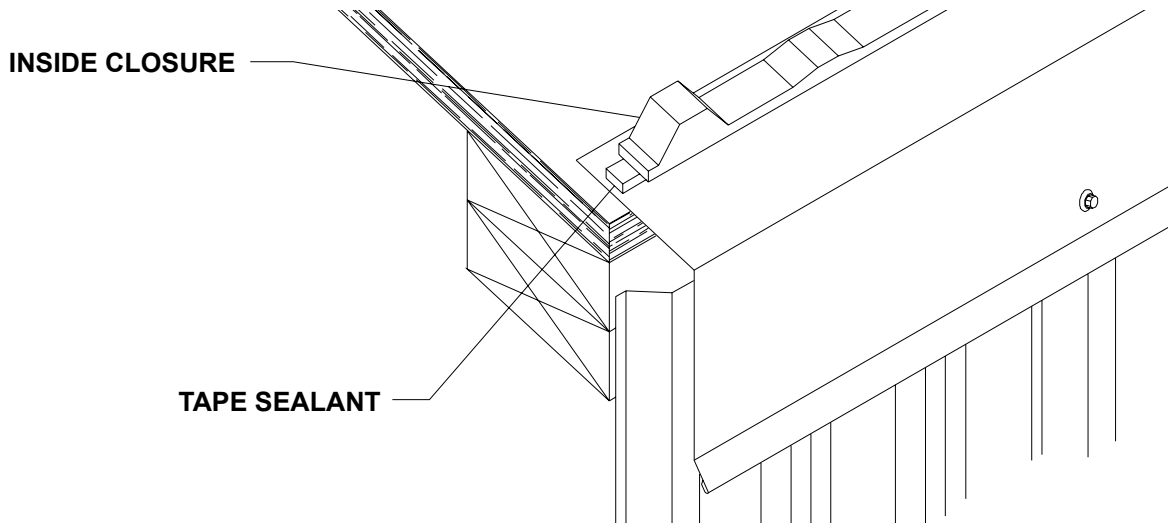

INSTALLING FIRST PANEL

STEP 2

1. Install the first panel over the Inside Closure to allow for desired overhang. Make sure the panel is square to the eave and rake.
2. Fasten through panel, closure, and sealants into decking with appropriate amount of fasteners to meet local building code. (See fastening patterns on pages 13 and 14). Fasteners must penetrate closure and sealant.
3. After securing panel at eave, repeat the fastening pattern at the appropriate spacing to meet local building codes.

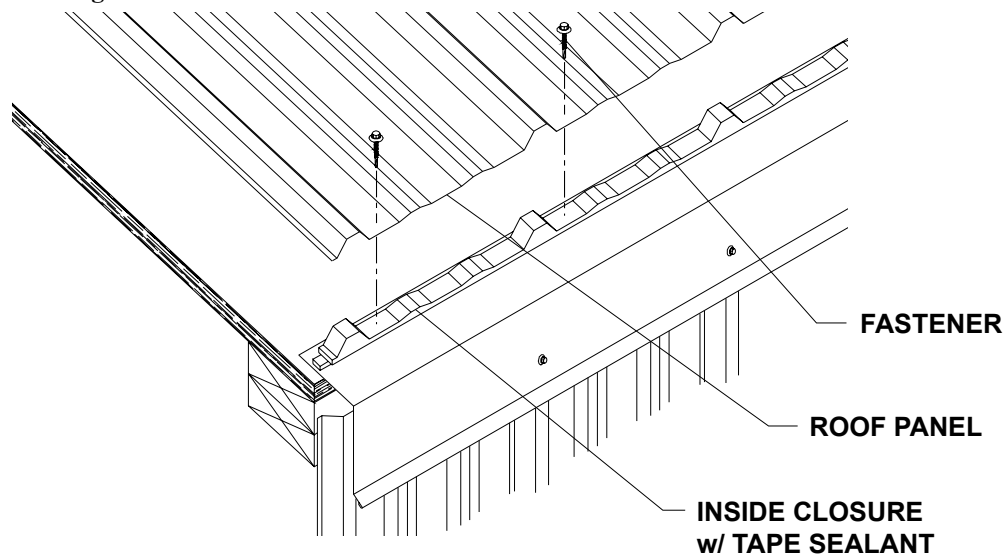

INSTALLING SECOND PANEL

STEP 3

1. Apply a row of Tape Sealant across and over the ribs of the first panel about 3" from panel end.
2. Install the second panel over the first panel and Tape Sealant with a 6" Endlap. **Fasten through both panels and Tape Sealant into support with appropriate amount of fasteners to meet local building code. (See fastening patterns on pages 13 and 14). Fasteners must penetrate sealant.**
3. After securing panel at eave, repeat the fastening pattern at the appropriate spacing to meet local building codes.

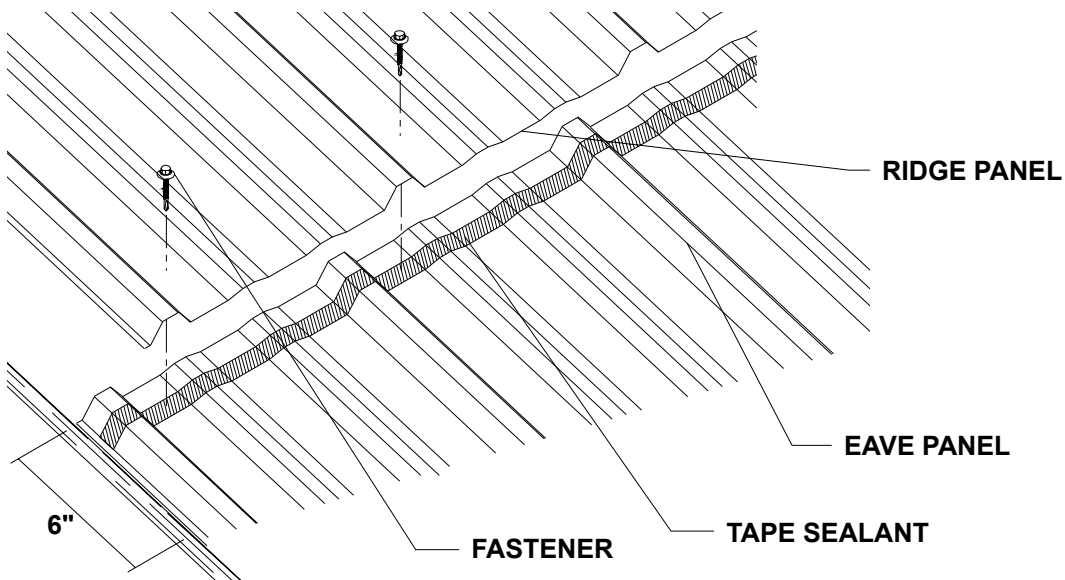

INSTALLING SECOND EAVE PANEL

STEP 4

1. Place the lapping seam of the second panel on top of previously installed panel so that panel ends are flush at eave (See below).
2. **Fasten through panel, closure, and Tape Sealant into support with appropriate amount of fasteners to meet local building code. (See fastening patterns on pages 13 and 14). Fasteners must penetrate closure and sealant.**
3. After securing panel at eave, repeat the fastening pattern at the appropriate spacing to meet local building codes.

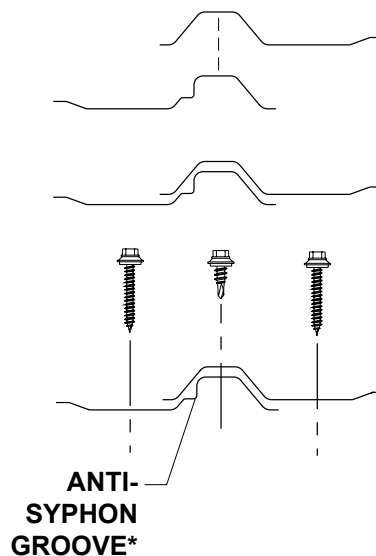
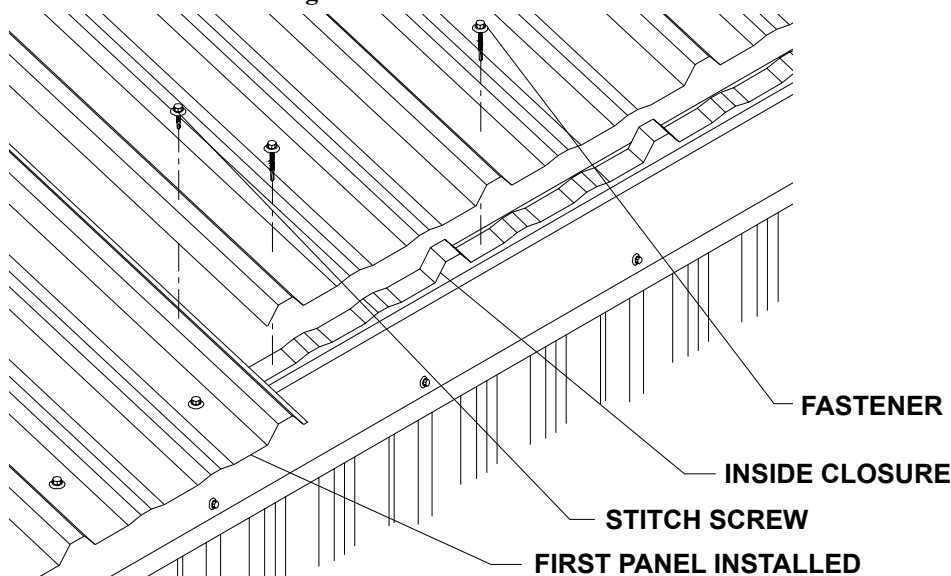

*PANELS WITHOUT AN ANTI-SYPHON GROOVE REQUIRE TAPE SEALANT IN THE SIDELAP.

14" UNIVERSAL RIDGE DETAIL

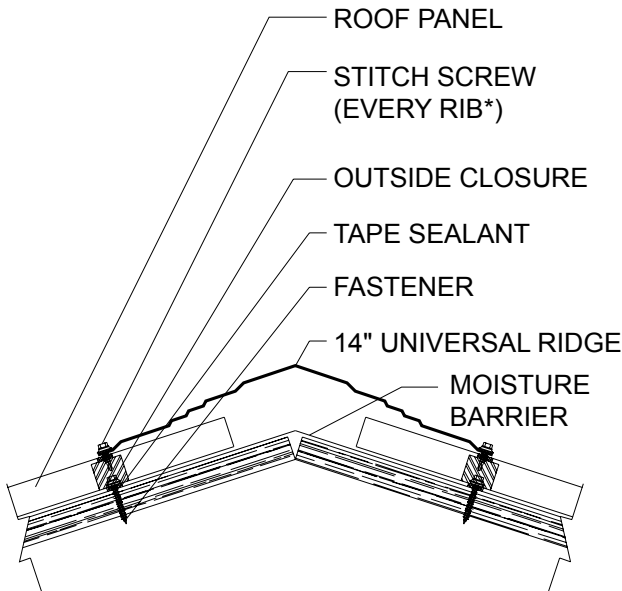

* FASTENER SPACING TO BE 8" - 12" O.C.

RIDGE / HIP COVER DETAIL

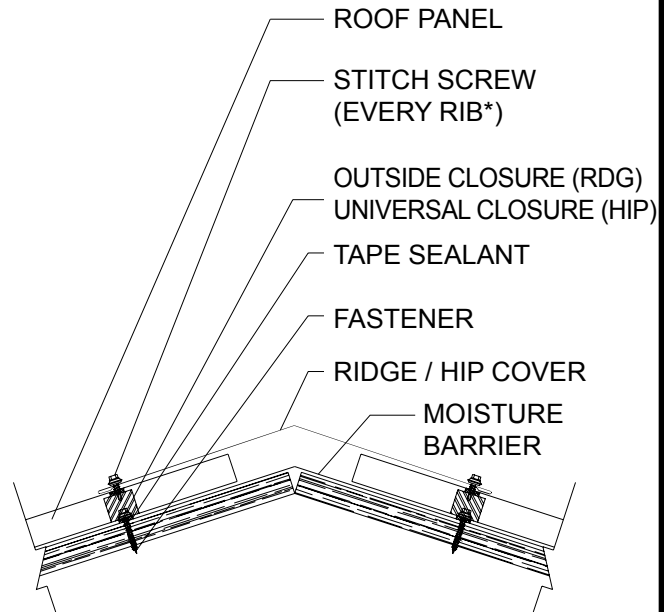

* FASTENER SPACING TO BE 8" - 12" O.C.

VENTED RIDGE DETAIL

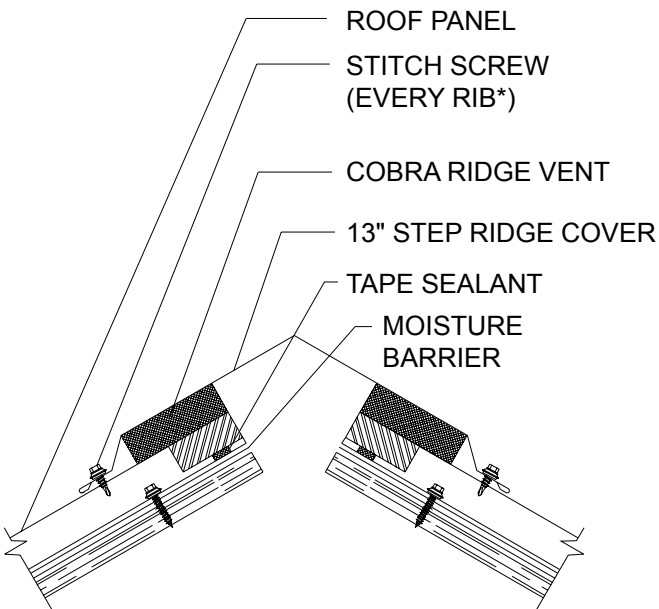

* FASTENER SPACING TO BE 8" - 12" O.C.

GABLE TRIM DETAIL

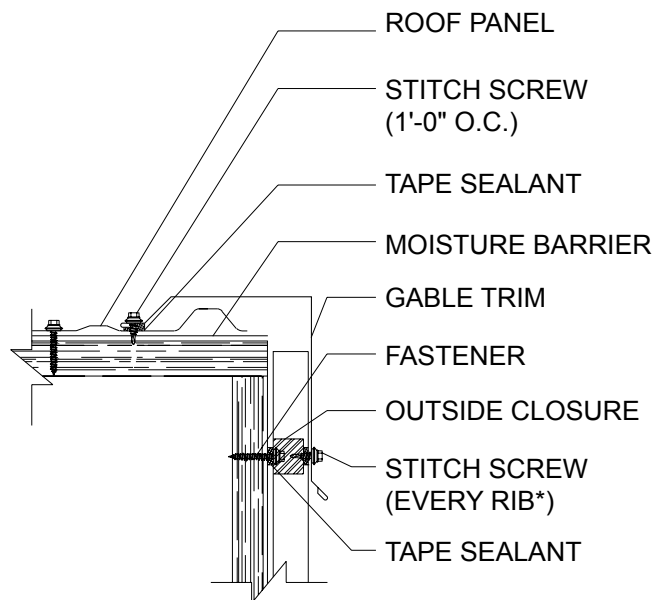

* FASTENER SPACING TO BE 8" - 12" O.C.

EAVE DETAIL

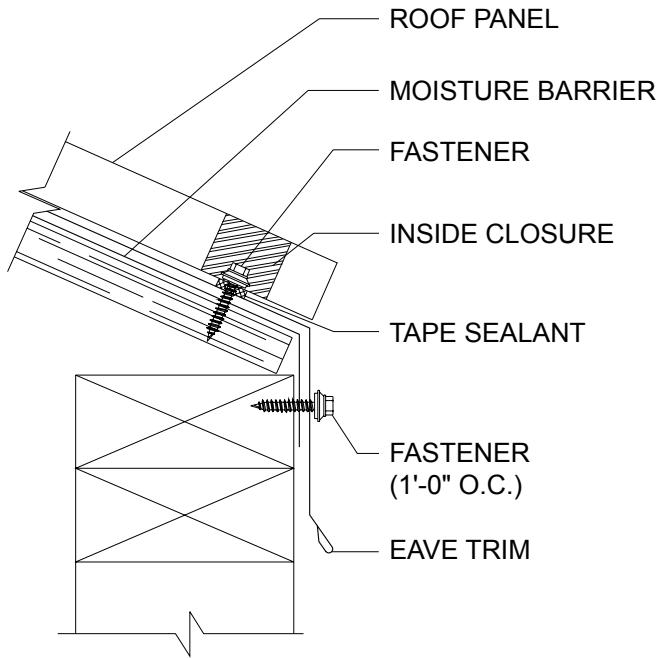

GUTTER DETAIL

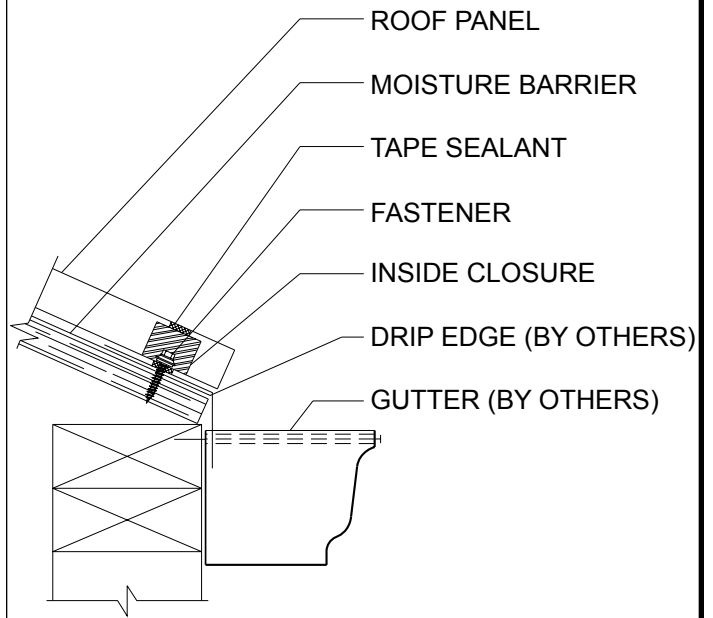

VALLEY DETAIL

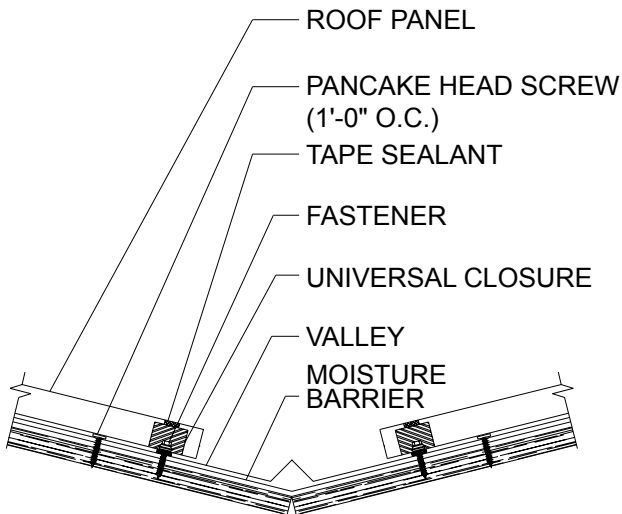

PITCH BREAK DETAIL

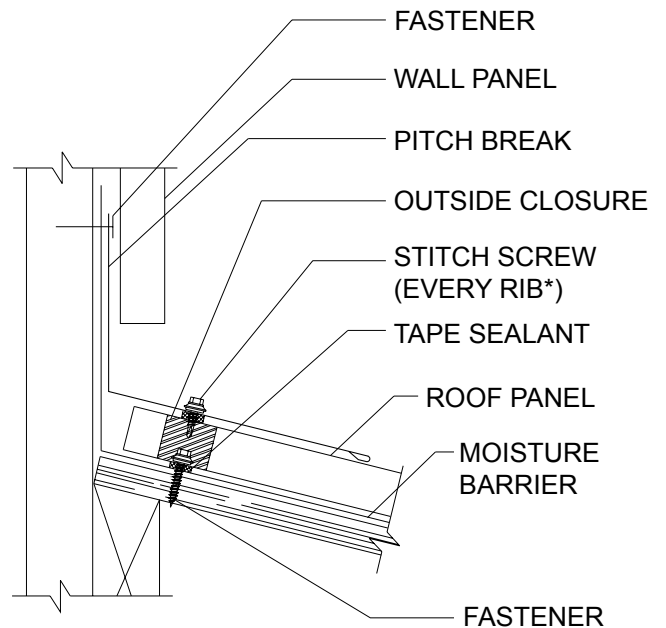

* FASTENER SPACING TO BE 8" - 12" O.C.

CHIMNEY / CRICKET DETAIL

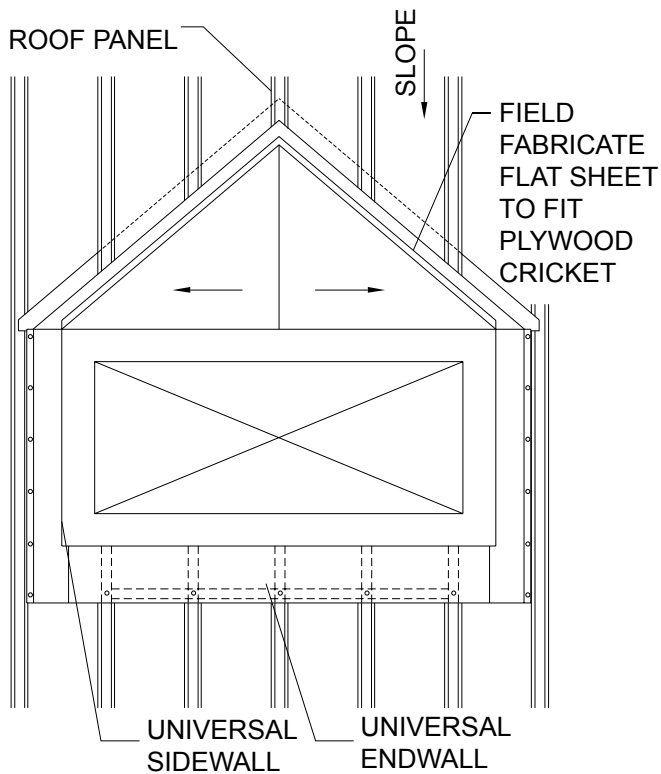
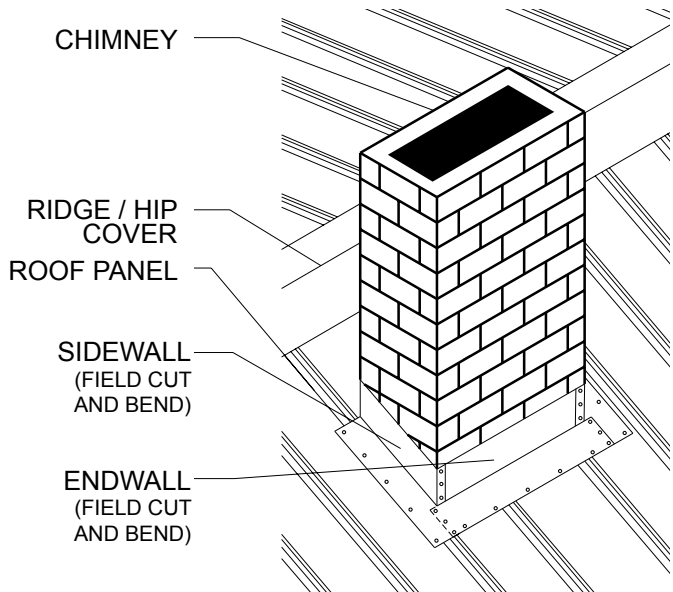

ROOF PENETRATION DETAIL

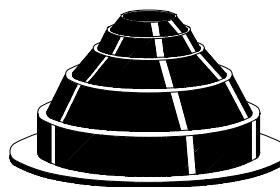
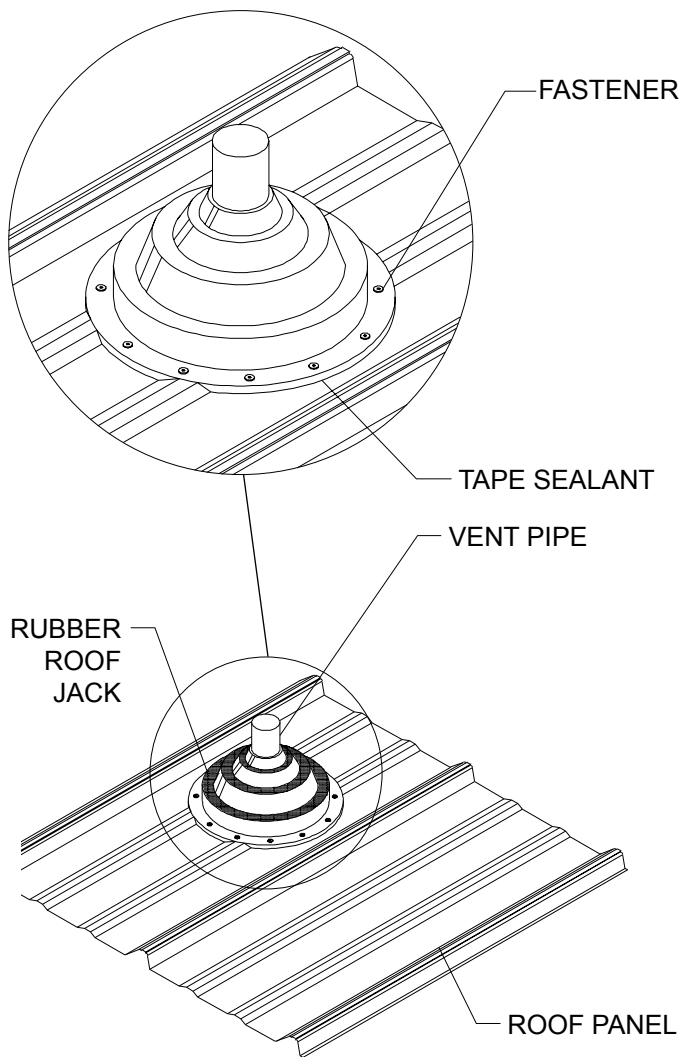

AVAILABLE SIZES

- MINI (1/4" TO 1 1/8" O.D. PIPE)
- #2 (1 3/4" TO 3" O.D. PIPE)
- #4 (3" TO 6" O.D. PIPE)
- #6 (6" TO 9" O.D. PIPE)
- #8 (7" TO 13" O.D. PIPE)

Though factory applied pre-painted finishes are very durable and will last many years, eventually it may be desirable to thoroughly clean or repaint them.

Dirt pickup may cause apparent discoloration of the paint when it has been exposed in some dirt-laden environments for long periods of time. In areas of strong sunlight, slight chalking may cause some change in appearance. A good cleaning will often restore the appearance of these buildings and render repainting unnecessary. An occasional light cleaning will help maintain a good appearance.

In many cases, simply washing the building with plain water using a hose or pressure sprayer will be adequate. In areas where heavy dirt deposits dull the surface, a cloth or soft bristle brush and solution of water and detergent ($\frac{1}{3}$ cup of laundry detergent per gallon of water for example) may be used. This should be followed by an adequate rinse of water. Do not use wire brushes, abrasives, or cleaning tools which will damage the coating surface.

Mildew may occur in areas subject to high humidity but is not normally a problem due to the high inherent mildew resistance of the baked finish that is used. To remove mildew along with the dirt, the following solution is recommended.

- $\frac{1}{3}$ cup detergent (Tide® or equivalent)
- $\frac{2}{3}$ cup trisodium phosphate (Solex® or equivalent)
- 1 quart of 5% sodium hypochlorite solution (Clorox® or equivalent)
- 3 quarts of water

Strong solvents and abrasive type cleaners should be avoided. Most organic solvents are flammable and toxic and must be handled accordingly. When using a solvent, consult maintenance professionals and label instructions for proper handling and disposal of washings. If required, a mild solvent such as mineral spirits can be used to remove caulking compounds, oil, grease, tars, wax, and similar substances. Use a cloth dampened with mineral spirits and apply only to areas which are contaminated. Follow up the use of this mild solvent with detergent cleaning and rinsing.

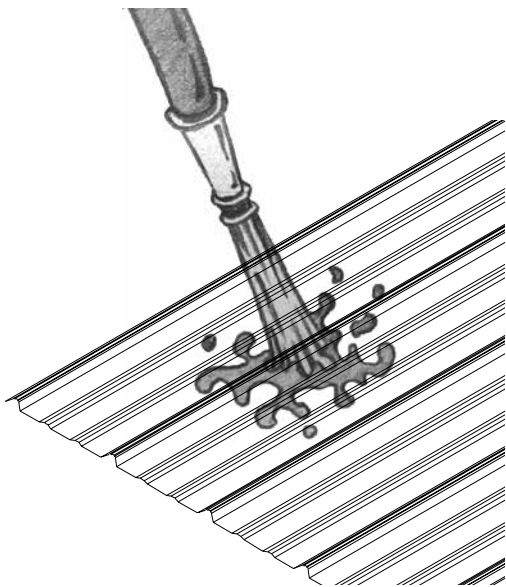

**HOSE OR PRESSURE SPRAY
FOR ADEQUATE CLEANING**



**DO NOT USE A
WIRE BRUSH**



**USE MILD DETERGENT AND WATER
FOR HEAVY DIRT DEPOSITS**

