

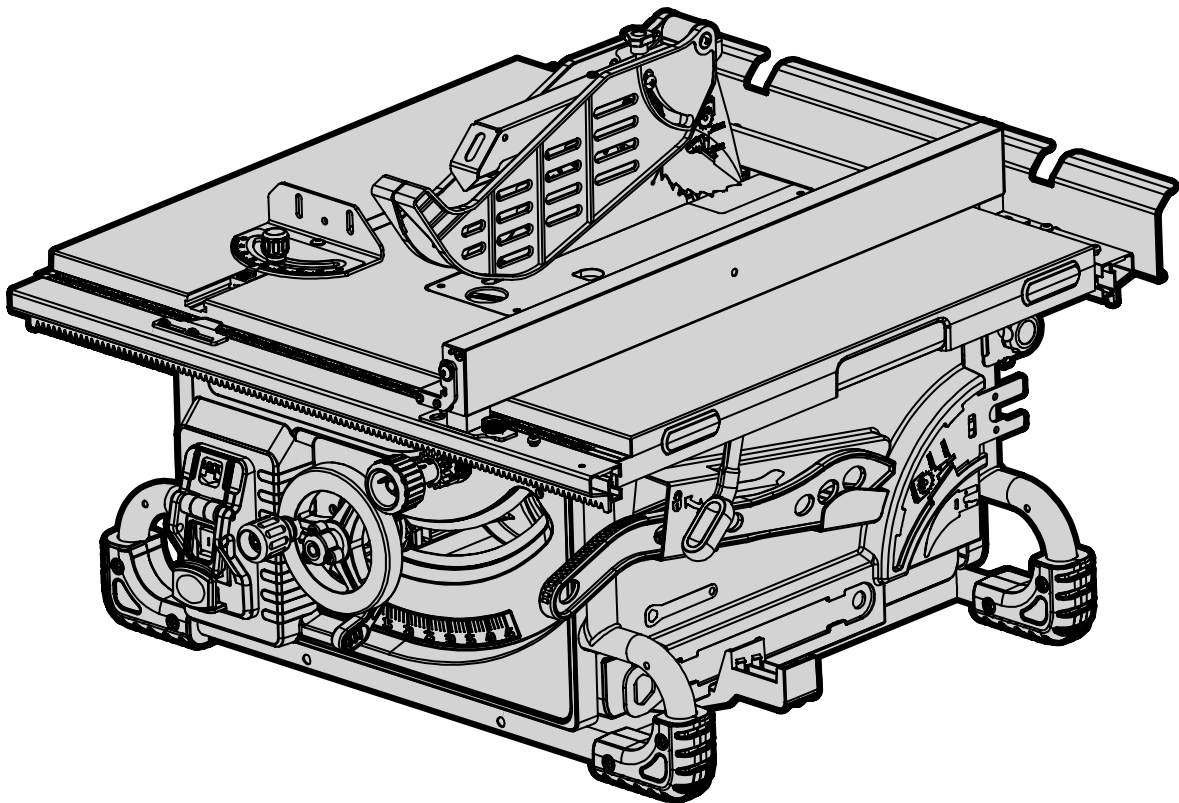

MODEL TT1015

10-INCH BENCHTOP TABLE SAW

Instruction Manual



NEED HELP? CONTACT US!

Have product questions? Need technical support? Please feel free to contact us:

 **1-800-232-1195 (M-F 8AM-5PM CST)** |  **TECHSUPPORT@WENPRODUCTS.COM**

IMPORTANT: Your new tool has been engineered and manufactured to WEN's highest standards for dependability, ease of operation, and operator safety. When properly cared for, this product will supply you years of rugged, trouble-free performance. Pay close attention to the rules for safe operation, warnings, and cautions. If you use your tool properly and for its intended purpose, you will enjoy years of safe, reliable service.

For replacement parts and the most up-to-date instruction manuals, visit ***WENPRODUCTS.COM***

CONTENTS

WELCOME	3
Introduction	3
Specifications.....	3
SAFETY	4
General Safety Rules	4
Specific Rules for Your Table Saw.....	6
Electrical Information.....	10
BEFORE OPERATING	11
Unpacking & Packing List.....	11
Know Your Table Saw	12
Assembly	13
OPERATION & MAINTENANCE	16
Operation	16
Adjustments.....	25
Maintenance	30
Troubleshooting Guide.....	32
Exploded View & Parts List.....	33
Warranty Statement.....	37

To purchase accessories for your tool, visit ***WENPRODUCTS.COM***

10-Inch Benchtop Table Saw Rolling Stand (Model TT1088)

8-inch Dado Blade Set (Model BL088D)

Zero Clearance Dado Insert (Model TT1015-DADO)

10-Inch Saw Blades (Models BL1012, BL1024, BL1024C, BL1028, BL1032-2, BL1040, BL1040C, BL1060, BL1060C, BL1080, BL1080C)

INTRODUCTION

Thanks for purchasing the WEN Table Saw. We know you are excited to put your tool to work, but first, please take a moment to read through the manual. Safe operation of this tool requires that you read and understand this operator's manual and all the labels affixed to the tool. This manual provides information regarding potential safety concerns, as well as helpful assembly and operating instructions for your tool.

 **SAFETY ALERT SYMBOL:** Indicates danger, warning, or caution. The safety symbols and the explanations with them deserve your careful attention and understanding. Always follow the safety precautions to reduce the risk of fire, electric shock or personal injury. However, please note that these instructions and warnings are not substitutes for proper accident prevention measures.

NOTE: The following safety information is not meant to cover all possible conditions and situations that may occur. WEN reserves the right to change this product and specifications at any time without prior notice.

At WEN, we are continuously improving our products. If you find that your tool does not exactly match this manual, please visit wenproducts.com for the most up-to-date manual or contact our customer service at **1-800-232-1195**.

Keep this manual available to all users during the entire life of the tool and review it frequently to maximize safety for both yourself and others.

SPECIFICATIONS

Model Number	TT1015
Motor	120V, 60Hz, 15A
No-Load Speed	4,800 RPM
Blade Dimensions	10" Diameter, 5/8" Arbor, 40T, 1.6mm Thick, 2.5mm Kerf
Blade Part Number	BL1040
Max Depth of Cut	At 90° - 3-1/8"
	At 45° - 2-1/4"
Max. Rip Right of Blade	28"
Dado Blades	Up to 8" Diameter, Up to 13/16" Width
Dust Port Diameter	2-1/2"
Fence	1" W x 2.36" H
Auxiliary Fence	1.10" W x 0.47" H (28mm x 12 mm)
Table Dimensions	26-1/4" x 22"
Product Weight	61.3 Pounds
Product Dimensions	36.14" x 43.75" x 20.28"

GENERAL SAFETY RULES

 **WARNING!** Read all safety warnings and all instructions. Failure to follow the warnings and instructions may result in electric shock, fire and/or serious injury.

Safety is a combination of common sense, staying alert and knowing how your item works. The term “power tool” in the warnings refers to your mains-operated (corded) power tool or battery-operated (cordless) power tool.

SAVE THESE SAFETY INSTRUCTIONS.

WORK AREA SAFETY

- 1. Keep work area clean and well lit.** Cluttered or dark areas invite accidents.
- 2. Do not operate power tools in explosive atmospheres,** such as in the presence of flammable liquids, gases or dust. Power tools create sparks which may ignite the dust or fumes.
- 3. Keep children and bystanders away while operating a power tool.** Distractions can cause you to lose control.

ELECTRICAL SAFETY

- 1. Power tool plugs must match the outlet.** Never modify the plug in any way. Do not use any adapter plugs with earthed (grounded) power tools. Unmodified plugs and matching outlets will reduce risk of electric shock.
- 2. Avoid body contact with earthed or grounded surfaces such as pipes, radiators, ranges and refrigerators.** There is an increased risk of electric shock if your body is earthed or grounded.
- 3. Do not expose power tools to rain or wet conditions.** Water entering a power tool will increase the risk of electric shock.
- 4. Do not abuse the cord.** Never use the cord for carrying, pulling or unplugging the power tool. Keep cord away from heat, oil, sharp edges or moving parts. Damaged or entangled cords increase the risk of electric shock.
- 5. When operating a power tool outdoors, use an extension cord suitable for outdoor use.** Use of a cord suitable for outdoor use reduces the risk of electric shock.
- 6. If operating a power tool in a damp location is unavoidable, use a ground fault circuit interrupter (GFCI) protected supply.** Use of a GFCI reduces the risk of electric shock.

PERSONAL SAFETY

- 1. Stay alert, watch what you are doing and use common sense when operating a power tool.** Do not use a power tool while you are tired or under the influence of drugs, alcohol or medication. A moment of inattention while operating power tools may result in serious personal injury.
- 2. Use personal protective equipment.** Always wear eye protection. Protective equipment such as a respiratory mask, non-skid safety shoes and hearing protection used for appropriate conditions will reduce the risk of personal injury.
- 3. Prevent unintentional starting.** Ensure the switch is in the off-position before connecting to power source and/or battery pack, picking up or carrying the tool. Carrying power tools with your finger on the switch or energizing power tools that have the switch on invites accidents.
- 4. Remove any adjusting key or wrench before turning the power tool on.** A wrench or a key left attached to a rotating part of the tool may result in personal injury.
- 5. Do not overreach.** Keep proper footing and balance at all times. This enables better control of the power tool in unexpected situations.
- 6. Dress properly.** Do not wear loose clothing or jewelry. Keep your hair and clothing away from moving parts. Loose clothes, jewelry or long hair can be caught in moving parts.
- 7. If devices are provided for the connection of dust extraction and collection facilities, ensure these are connected and properly used.** Use of dust collection can reduce dust-related hazards.
- 8. Do not let familiarity gained from frequent use of tools allow you to become complacent and ignore tool safety principles.** A careless action can cause severe injury within a fraction of a second.

GENERAL SAFETY RULES

 **WARNING!** Read all safety warnings and all instructions. Failure to follow the warnings and instructions may result in electric shock, fire and/or serious injury.

Safety is a combination of common sense, staying alert and knowing how your item works. The term “power tool” in the warnings refers to your mains-operated (corded) power tool or battery-operated (cordless) power tool.

SAVE THESE SAFETY INSTRUCTIONS.

POWER TOOL USE AND CARE

1. Do not force the power tool. Use the correct power tool for your application. The correct power tool will do the job better and safer at the rate for which it was designed.

2. Do not use the power tool if the switch does not turn it on and off. Any power tool that cannot be controlled with the switch is dangerous and must be repaired.

3. Disconnect the plug from the power source and/or the battery pack from the power tool before making any adjustments, changing accessories, or storing power tools. Such preventive safety measures reduce the risk of starting the power tool accidentally.

4. Store idle power tools out of the reach of children and do not allow persons unfamiliar with the power tool or these instructions to operate the power tool. Power tools are dangerous in the hands of untrained users.

5. Maintain power tools. Check for misalignment or binding of moving parts, breakage of parts and any other condition that may affect the power tool’s operation. If damaged, have the power tool repaired before use. Many accidents are caused by poorly maintained power tools.

6. Keep cutting tools sharp and clean. Properly maintained cutting tools with sharp cutting edges are less likely to bind and are easier to control.

7. Use the power tool, accessories and tool bits, etc. in accordance with these instructions, taking into account the working conditions and the work to be performed. Use of power tool for operations different from those intended could result in a hazardous situation.

8. Use clamps to secure your workpiece to a stable surface. Holding a workpiece by hand or using your body to support it may lead to loss of control.

9. KEEP GUARDS IN PLACE and in working order.

10. Keep handles and grasping surfaces dry, clean and free from oil and grease. Slippery handles and grasping surfaces do not allow for safe handling and control of the tool in unexpected situations.

SERVICE

1. Have your power tool serviced by a qualified repair person using only identical replacement parts. This will ensure that safety of the power tool is maintained.

CALIFORNIA PROPOSITION 65 WARNING

Some dust created by power sanding, sawing, grinding, drilling, and other construction activities may contain chemicals, including lead, known to the State of California to cause cancer, birth defects, or other reproductive harm. Wash hands after handling. Some examples of these chemicals are:

- Lead from lead-based paints.
- Crystalline silica from bricks, cement, and other masonry products.
- Arsenic and chromium from chemically treated lumber.

Your risk from these exposures varies depending on how often you do this type of work. To reduce your exposure to these chemicals, work in a well-ventilated area with approved safety equipment such as dust masks specially designed to filter out microscopic particles.

SPECIFIC RULES FOR YOUR TABLE SAW



 **WARNING!** Do not operate the power tool until you have read and understood the following instructions and the warning labels.

TABLE SAW SAFETY

1. Never place your hands in the vicinity of, or in line with, the saw blade.
 2. Always wear ANSI Z87.1 approved eye protection, as well as hearing protection and respiratory protection.
 3. Avoid kickback. Keep the blade sharp and the rip fence parallel to the saw blade. Make sure the riving knife, anti-kickback devices, and the blade guard are in place, properly aligned, and functional. Do not release a workpiece before passing it completely through the blade. Do not rip a workpiece that is twisted or warped. Do not attempt to pull the workpiece backwards out of a cut while the blade is still turning.
 4. Always use a properly functioning saw blade guard, riving knife and anti-kickback device for every operation for which it can be used, including all through sawing.
 5. Use a push-stick or push-block when required, especially when ripping narrow workpieces. A push stick is supplied with the saw.
 6. Do not perform any operation freehand. Always use the fence, miter gauge, or both to support and guide the workpiece.
 7. Pay particular attention to instructions on reducing the risk of kickback.
 8. Never reach around or over the saw blade.
 9. Turn off tool and wait for the saw blade to come to a complete stop before moving workpiece or changing settings.
 10. Never stand directly in line with the saw blade. Always position your body on the same side of the saw blade as the fence.
 11. Support large panels to minimize the risk of blade pinching or kickback.
 12. Keep hands out of the line of the saw blade.
 13. **DON'T USE IN DANGEROUS ENVIRONMENT.** Don't use power tools in damp or wet locations, or expose them to rain. Keep work area well lit. Do not use power tools in the presence of flammable liquids or gases.
 14. **MAKE WORKSHOP KID PROOF** with padlocks, master switches, or by removing starter keys.
 15. **USE THE RIGHT TOOL.** Don't force tool or attachment to do a job for which it was not designed.
 16. **WEAR PROPER APPAREL.** Do not wear loose clothing, gloves, neckties, rings, bracelets, or other jewelry which may get caught in moving parts. Nonslip footwear is recommended. Tie back long hair.
 17. **CHECK DAMAGED PARTS.** Before further use of the tool, a guard or other part that is damaged should be carefully checked to determine that it will operate properly and perform its intended function - check for alignment of moving parts, binding of moving parts, breakage of parts, mounting, and any other conditions that may affect its operation. A guard or other part that is damaged should be properly repaired or replaced.
 18. **REMOVE ALL ACCESSORIES** from the table prior to transporting the saw.
 19. **DANGER - NEVER** attempt to free a stalled blade without first turning the saw OFF and unplugging it.
 20. **PROVIDE ADEQUATE SUPPORT** to long or wide workpieces.
 21. **AVOID AWKWARD OPERATIONS** and hand positions, where a sudden slip could cause your hand to move into the blade or its path.
 22. **SECURELY MOUNT THE TABLE SAW** to a workbench or stand before performing any cutting operations.
 23. **NEVER CUT METALS** or any material that creates hazardous dust.
- ### SAW BLADE SAFETY
1. Always wear protective gloves when handling saw blades.
 2. Only use blades with correct size and type for both your table saw and your workpiece.
 - The rated diameter of the saw blade is 10 inches with a 5/8 inch arbor.
 - The no-load speed of the table saw is 4800 RPM. The maximum permissible speed of your saw blade should always be higher than the no-load rotational speed of the saw.

SPECIFIC RULES FOR YOUR TABLE SAW

 **WARNING!** Do not operate the power tool until you have read and understood the following instructions and the warning labels.

3. Never use damaged or deformed saw blades. Only use sharp blades.
4. Install the saw blade in the correct orientation indicated in the instructions.
5. Keep hands out of path of saw blade. Never use your hands to remove sawdust, chips or workpiece near the saw blade or the cutting path of the saw.
6. Never reach around the blade or in back of the blade.
7. Do not use blades made from high-speed steel, abrasive blades, metal-cutting blades or masonry-cutting blades. The guards of this saw are not designed to protect against the failure of such blades.
8. The use of accessories or attachments not recommended by the manufacturer may result in a risk of personal injury.

GUARD-RELATED WARNINGS

1. Keep guards in place. Guards must be in working order and be properly mounted. A guard that is loose, damaged, or is not functioning correctly must be repaired or replaced.
2. Always use saw blade guard, riving knife and anti-kickback device for every through-cutting operation. For through-cutting operations where the saw blade cuts completely through the thickness of the workpiece, the guard and other safety devices help reduce the risk of injury.
3. Immediately reattach the guarding system after completing an operation (such as rabbeting, dadoing or resawing cuts) which requires removal of the guard, riving knife and/or anti-kickback device. The guard, riving knife, and anti-kickback device help to reduce the risk of injury.
4. Make sure the saw blade is not contacting the guard, riving knife or the workpiece before the switch is turned on. Inadvertent contact of these items with the saw blade could cause a hazardous condition.
5. Adjust the riving knife as described in this instruction manual. Incorrect spacing, positioning and alignment can make the riving knife ineffective in reducing the likelihood of kickback.
6. For the riving knife and anti-kickback device to work, they must be engaged in the workpiece. The riving knife and anti-kickback device are ineffective when cutting workpieces that are too short to be engaged with the riving knife and anti-kickback device. Under these conditions a kickback cannot be prevented by the riving knife and anti-kickback device.
7. Use the appropriate saw blade for the riving knife. For the riving knife to function properly, the saw blade diameter must match the appropriate riving knife and the body of the saw blade must be thinner than the thickness of the riving knife and the cutting width of the saw blade must be wider than the thickness of the riving knife.

CUTTING PROCEDURES WARNINGS

1. **DANGER:** Never place your fingers or hands in the vicinity of or in line with the saw blade. A moment of inattention or a slip could direct your hand towards the saw blade and result in serious personal injury.
2. Feed the workpiece into the saw blade or cutter only against the direction of rotation. Feeding the workpiece in the same direction that the saw blade is rotating above the table may result in the workpiece, and your hand, being pulled into the saw blade.
3. Never use the miter gauge to feed the workpiece when ripping and do not use the rip fence as a length stop when cross cutting with the miter gauge. Guiding the workpiece with the rip fence and the miter gauge at the same time increases the likelihood of saw blade binding and kickback.
4. When ripping, always apply force to the workpiece between the fence and the saw blade. Use a push stick when the distance between the fence and the saw blade is less than 6 inches (150mm), and use a push block when this distance is less than 2 inches (50mm). Work helping devices will keep your hand at a safe distance from the saw blade.
5. Use only the push stick provided by the manufacturer or constructed in accordance with the instructions. This push stick provides sufficient separation between the hand and the saw blade.

SPECIFIC RULES FOR YOUR TABLE SAW

 **WARNING!** Do not operate the power tool until you have read and understood the following instructions and the warning labels.

6. Never use a damaged or cut push stick. It may break causing your hand to slip into the saw blade.

7. Do not perform any operation freehand. Always use either the rip fence or the miter gauge to position and guide the workpiece. Freehand means using your hands to support or guide the workpiece, in lieu of a rip fence or miter gauge. Freehand sawing leads to misalignment, binding and kickback.

8. Never reach around or over a rotating saw blade. This may lead to accidental contact with moving saw blade.

9. Provide auxiliary workpiece support to the rear and/or sides of the saw table for long and/or wide workpieces to keep them level. A long and/or wide workpiece has a tendency to pivot on the table's edge, causing loss of control, saw blade binding and kickback.

10. Feed workpiece at an even pace. Do not bend or twist the workpiece. If jamming occurs, turn the tool off immediately, unplug the tool then clear the jam. Jamming the saw blade by the workpiece can cause kickback or stall the motor.

11. Do not remove pieces of cut-off material while the saw is running. The material may become trapped between the fence or inside the saw blade guard and the saw blade, pulling your fingers into the saw blade. Turn the saw off and wait until the saw blade stops before removing material.

12. Use an auxiliary fence in contact with table top when ripping workpieces less than 2mm thick. A thin workpiece may wedge under rip fence and create kickback.

KICKBACK CAUSES AND RELATED WARNINGS

Kickback is a sudden reaction of the workpiece due to a pinched, jammed saw blade or misaligned line of cut in the workpiece with respect to the saw blade or when a part of the workpiece binds between the saw blade and the rip fence or other fixed object. Most frequently during kickback, the workpiece is lifted from the table by the rear portion of the saw blade and is propelled towards the operator. Kickback is the result of saw misuse and/or incorrect operating procedures or conditions and can be avoided by taking proper precautions as given.

1. Never stand directly in line with the saw blade. Always position your body on the same side of the saw blade as the fence. Kickback may propel the workpiece at high velocity towards anyone standing in front and in line with the saw blade.

2. Never reach over or in back of the saw blade to pull or to support the workpiece. Accidental contact with the saw blade may occur or kickback may drag your fingers into the saw blade.

3. Never hold and press the workpiece that is being cut off against the rotating saw blade. Pressing the workpiece being cut off against the saw blade will create a binding condition and kickback.

4. Align the fence to be parallel with the saw blade. A misaligned fence will pinch the workpiece against the saw blade and create kickback.

5. Use a featherboard to guide the workpiece against the table and fence when making non-through cuts such as rabbeting, dadoing or resawing cuts. A featherboard helps to control the workpiece in the event of a kickback.

6. Use extra caution when making a cut into blind areas of assembled workpieces. The protruding saw blade may cut objects that can cause kickback.

7. Support large panels to minimize the risk of saw blade pinching and kickback. Large panels tend to sag under their own weight. Support(s) must be placed under all portions of the panel overhanging the table top.

8. Use extra caution when cutting a workpiece that is twisted, knotted, warped or does not have a straight edge to guide it with a miter gauge or along the fence. A warped, knotted, or twisted workpiece is unstable and causes misalignment of the kerf with the saw blade, binding and kickback.

9. Never cut more than one workpiece, stacked vertically or horizontally. The saw blade could pick up one or more pieces and cause kickback.

SPECIFIC RULES FOR YOUR TABLE SAW

 **WARNING!** Do not operate the power tool until you have read and understood the following instructions and the warning labels.

10. When restarting the saw with the saw blade in the workpiece, center the saw blade in the kerf so that the saw teeth are not engaged in the material. If the saw blade binds, it may lift up the workpiece and cause kickback when the saw is restarted.

11. Keep saw blades clean, sharp, and with sufficient set. Never use warped saw blades or saw blades with cracked or broken teeth. Sharp and properly set saw blades minimize binding, stalling and kickback.

TABLE SAW OPERATION WARNINGS

1. Turn off the table saw and disconnect the power cord when removing the table insert, changing the saw blade or making adjustments to the riving knife, ant kickback device or saw blade guard, and when the machine is left unattended. Precautionary measures will avoid accidents.

2. Never leave the table saw running unattended. Turn it off and don't leave the tool until it comes to a complete stop. An unattended running saw is an uncontrolled hazard.

3. Locate the table saw in a well-lit and level area where you can maintain good footing and balance. It should be installed in an area that provides enough room to easily handle the size of your workpiece. Cramped, dark areas, and uneven or slippery floors invite accidents.

4. Frequently clean and remove sawdust from under the saw table and/or the dust collection device. Accumulated sawdust is combustible and may self-ignite.

5. The table saw must be secured. A table saw that is not properly secured may move or tip over. Mount it securely to a benchtop or stand before cutting.

6. Remove tools, wood scraps, etc. from the table before the table saw is turned on. Distraction or a potential jam can be dangerous.

7. Always use saw blades with correct size and shape (diamond versus round) of arbor holes. Saw blades that do not match the mounting hardware of the saw will run off-center, causing loss of control.

8. Never use damaged or incorrect saw blade mounting means such as flanges, saw blade washers, bolts or nuts. These mounting means were specially designed for your saw, for safe operation and optimum performance.

9. Never stand on the table saw, do not use it as a stepping stool. Serious injury could occur if the tool is tipped or if the cutting tool is accidentally contacted.

10. Make sure that the saw blade is installed to rotate in the proper direction. Do not use grinding wheels, wire brushes, or abrasive wheels on a table saw. Improper saw blade installation or use of accessories not recommended may cause serious injury.

CAUTION: This means that if precautions are not heeded, it may result in minor or moderate injury and/or possible machine damage.

WARNING: This means that if precautions are not heeded, it could result in serious injury or possibly even death.

WARNING: The operation of any power tool can result in foreign objects being thrown into your eyes, which can result in severe eye damage. Before beginning power tool operation, always wear safety goggles or safety glasses with side shields and a full face shield when needed. Always use eye protection which is marked to comply with ANSI Z87.1.

WARNING: If the power cord requires replacement, this must be done by the manufacturer.

WARNING: Only cut wood on this table saw. Do not cut any plastic and metal on this saw.

WARNING: Always keep guards in place and in proper operating condition.

WARNING: Use blade guard for every applicable operation including all through cuts. If the guard is removed for special non-through cuts, such as dado or rabbet cuts, replace the blade guard before further use of the saw.

WARNING: Keep hands out of the line of the saw blade. Never reach around or over the saw blade.

ELECTRICAL INFORMATION

DOUBLE-INSULATED TOOLS

The tool's electrical system is double insulated where two systems of insulation are provided. This eliminates the need for the usual three-wire grounded power cord. Double insulated tools do not need to be grounded, nor should a means for grounding be added to the product. All exposed metal parts are isolated from the internal metal motor components with protecting insulation.

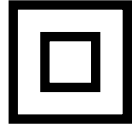

IMPORTANT: Servicing a double-insulated product requires extreme care and knowledge of the system, and should be done only by qualified service personnel using identical replacement parts. Always use original factory replacement parts when servicing.

1. **POLARIZED PLUGS.** To reduce the risk of electric shock, this equipment has a polarized plug (one blade is wider than the other). This plug will fit in a polarized outlet only one way. If the plug does not fit fully in the outlet, reverse the plug. If it still does not fit, contact a qualified electrician to install a proper outlet. Do not modify the machine plug or the extension cord in any way.
2. **GROUND FAULT CIRCUIT INTERRUPTER PROTECTION (GFCI)** should be provided on the circuit or outlet used for this power tool to reduce the risk of electric shock.
3. **SERVICE AND REPAIR.** To avoid danger, electrical appliances must only be repaired by qualified service technician using original replacement parts.

GUIDELINES AND RECOMMENDATIONS FOR EXTENSION CORDS

When using an extension cord, be sure to use one heavy enough to carry the current your product will draw. An undersized cord will cause a drop in line voltage resulting in loss of power and overheating. The table below shows the correct size to be used according to cord length and ampere rating. When in doubt, use a heavier cord. The smaller the gauge number, the heavier the cord.

AMPERAGE	REQUIRED GAUGE FOR EXTENSION CORDS			
	25 ft.	50 ft.	100 ft.	150 ft.
15A	14 gauge	12 gauge	Not Recommended	Not Recommended

1. **EXAMINE EXTENSION CORD BEFORE USE.** Make sure your extension cord is properly wired and in good condition. Always replace a damaged extension cord or have it repaired by a qualified person before using it.
2. **DO NOT ABUSE EXTENSION CORD.** Do not pull on cord to disconnect from receptacle; always disconnect by pulling on plug. Disconnect the extension cord from the receptacle before disconnecting the product from the extension cord. Protect your extension cords from sharp objects, excessive heat and damp/wet areas.
3. **USE A SEPARATE ELECTRICAL CIRCUIT FOR YOUR TOOL.** This circuit must not be less than a 12-gauge wire and should be protected with a 15A time-delayed fuse. Before connecting the motor to the power line, make sure the switch is in the OFF position and the electric current is rated the same as the current stamped on the motor nameplate. Running at a lower voltage will damage the motor.

UNPACKING & PACKING LIST

⚠ WARNING! Do not plug in or turn on the tool until it is fully assembled according to the instructions. Failure to follow the safety instructions may result in serious personal injury.

UNPACKING

With the help of a friend or trustworthy foe, carefully remove the table saw from the packaging. Make sure to take out all contents and accessories. Do not discard the packaging until everything is removed. Check the packing list below to make sure you have all of the parts and accessories. If any part is missing or broken, please contact our customer service at **1-800-232-1195** (M-F 8-5 CST), or email **techsupport@wenproducts.com**.

PACKING LIST

Components

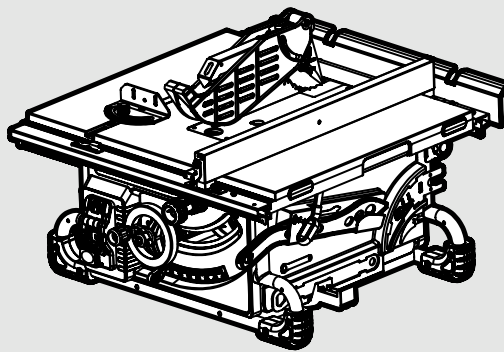

Table Saw (1)

Accessories & Tools



Table Extension Shafts (2)



Riving Knife (1)
(Pre-Installed)



Table Extension Rest (1)



Rip Fence (1)
(Stored on side of saw)

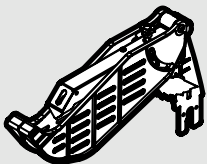

Blade Guard (1)

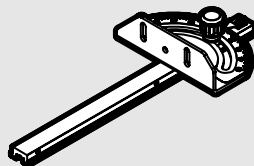

Miter Gauge (1)



Arbor Wrench (1)



Push Stick (1)

Hardware Bag (1)



6mm Flat Washers (2)

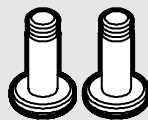

M6x10 Phillips-Head
Screw (2)

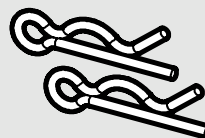

R Clips (2)

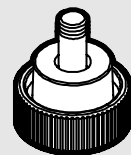

Fence Lock Knob (1)

KNOW YOUR TABLE SAW

TOOL PURPOSE

Make smooth, straight cuts easily with your WEN Table Saw. Refer to the following diagrams to become familiarized with all the parts and controls of your table saw. The components will be referred to later in the manual for assembly and operation instructions.

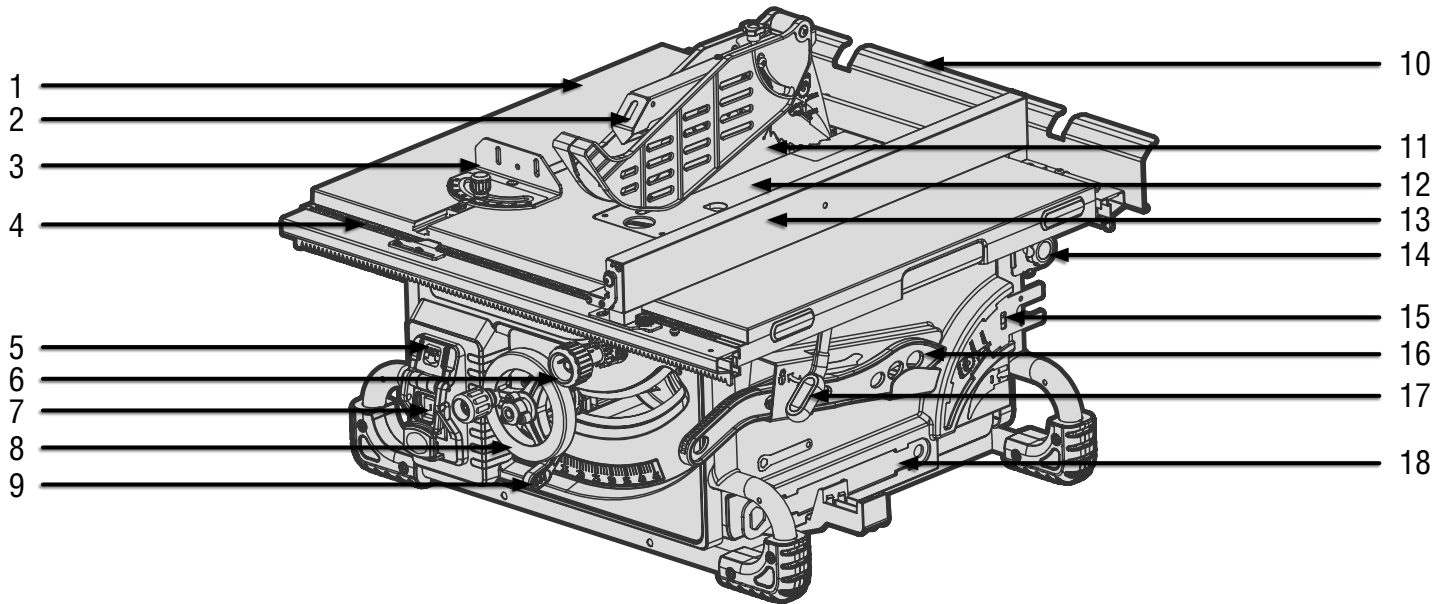

- | | | |
|--------------------------|----------------------------|----------------------------|
| 1. Worktable | 8. Height Adjustment Wheel | 15. Riving Knife & Storage |
| 2. Blade Guard | 9. Bevel Locking Lever | 16. Push Stick |
| 3. Miter Gauge | 10. Rear Extension | 17. Fence Lock Lever |
| 4. Fence Scale | 11. Saw Blade | 18. Tool Storage |
| 5. Switch Lock-out Cover | 12. Table Insert | 19. Dust Port |
| 6. Fence Adjustment Knob | 13. Rip Fence | 20. Fence Storage |
| 7. Power Switch | 14. Blade Guard Storage | 21. Miter Gauge Storage |

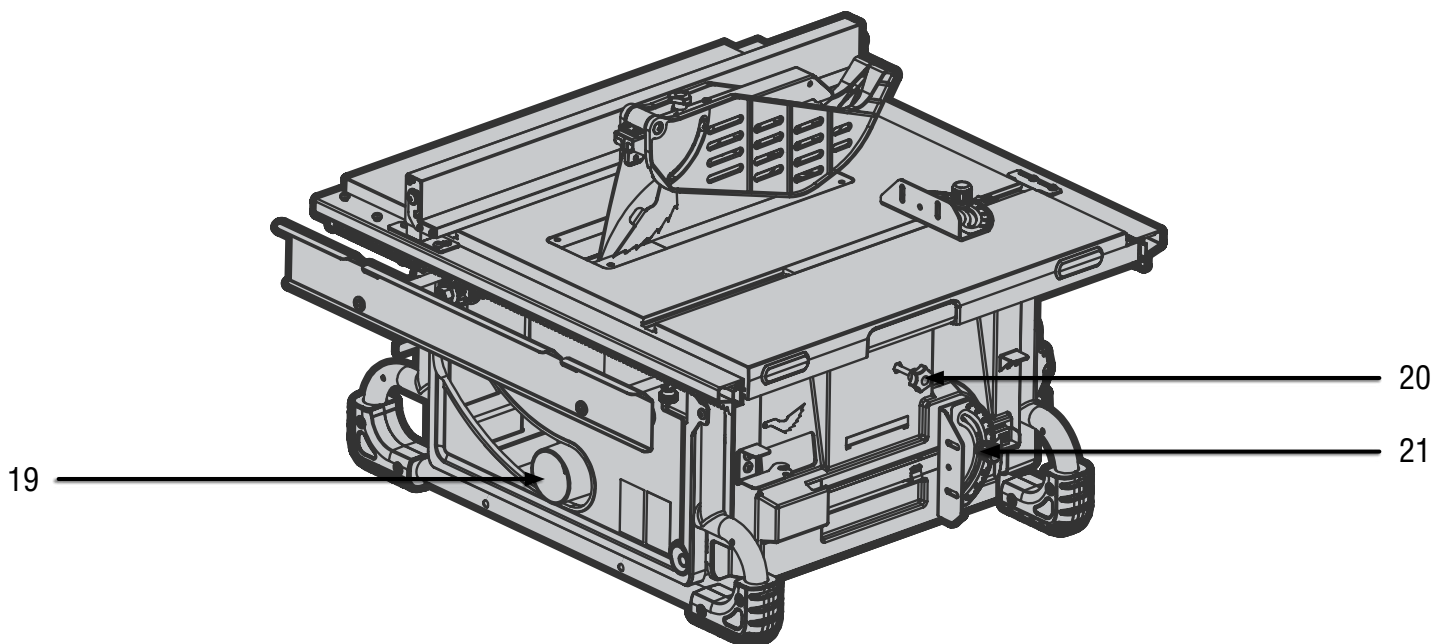

ASSEMBLY

⚠ WARNING! Do not plug in or turn on the tool until it is fully assembled according to the instructions. Read through and become familiarized with the following procedures of handling and adjusting your tool. Failure to follow the safety instructions may result in serious personal injury.

INSTALLING THE FENCE

NOTE: The fence is shipped in its storage position on the left side of the saw.

1. Loosen the lock knob (Fig. 2 - 1), then remove the fence assembly (Fig. 2 - 2).
2. Install the fence locking knob (Fig. 3 - 1) (found in the hardware bag) on the front rail.
3. Place the fence on the rails, with the mounting holes positioned over the (3) pre-installed mounting screws. Then tighten the fence locking knob (Fig. 4 - 1) to secure the fence.

NOTE: The fence can be installed in 1 of 2 positions. The inner position (closer to the blade) can be used for rip cuts up to 24" wide. The outer position can be used for rip cuts up to 28" wide.

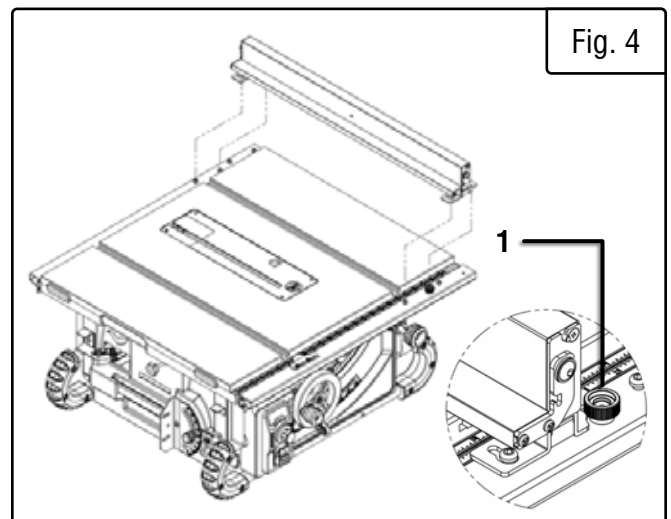
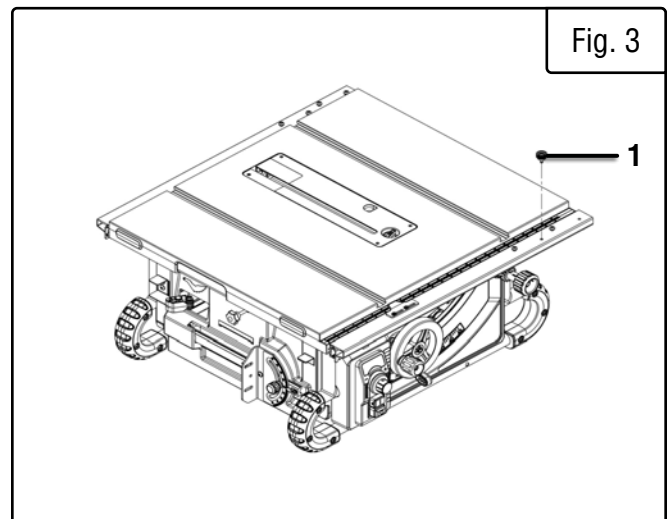
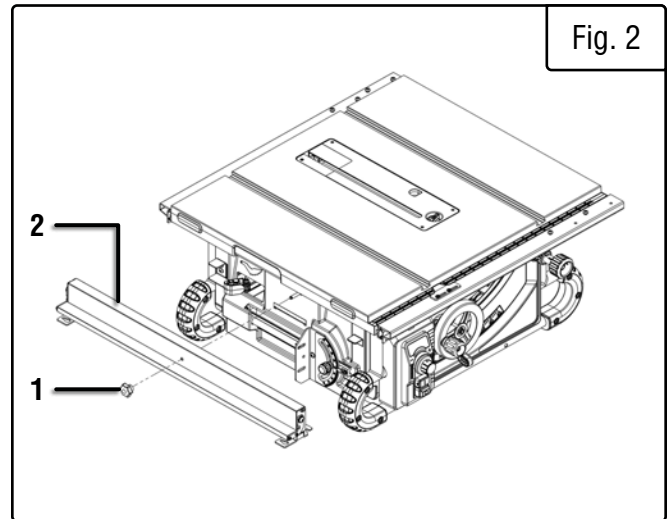

ASSEMBLY

INSTALLING THE TABLE EXTENSION

1. Use a Phillips-head screwdriver (not included) to attach the table extension rods (Fig. 5 - 1) to the table extension (Fig. 5 - 2) with the M6x10 screws and 6mm washers.

2. Loosen both knobs (Fig. 6 - 1) on the rear side of the saw and insert the extension rods into the holes. Once the table extension is in the desired position, tighten the knobs. To reposition the extension, loosen the knobs, adjust the extension to the desired position, and tighten the knobs.

3. Insert the R-clips (Fig. 7 - 1) into the holes in the two rear extension rods to secure the table extension.

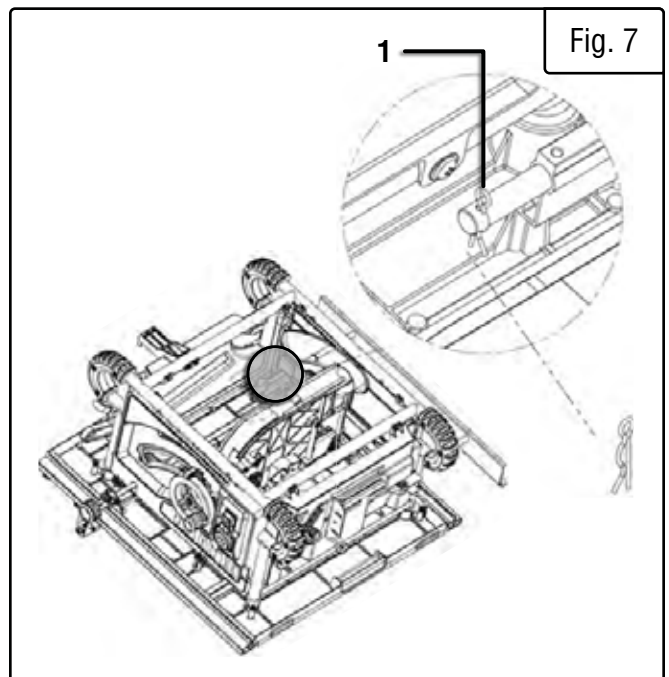
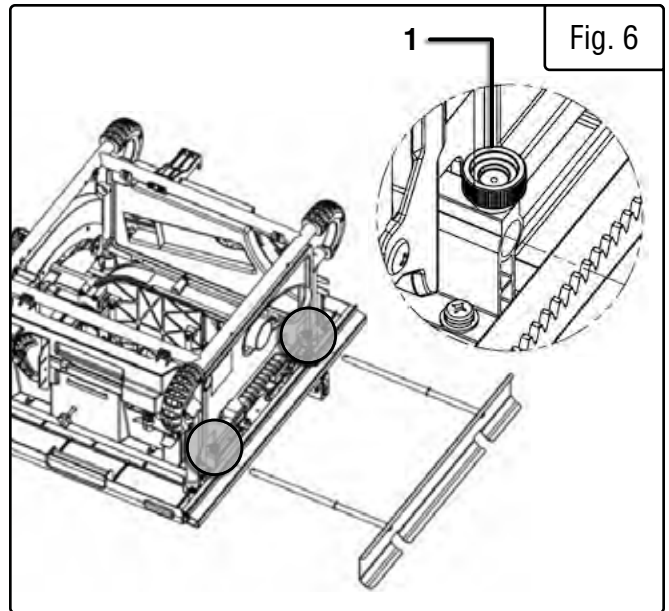
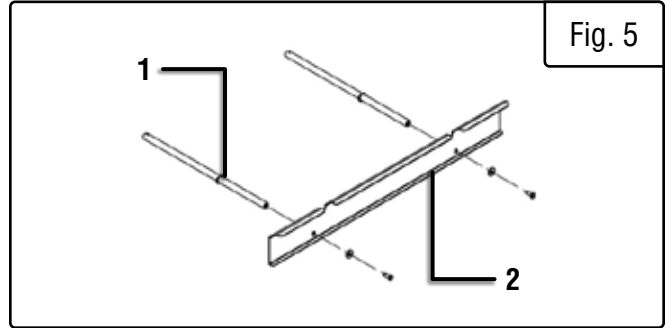

ASSEMBLY

INSTALLING THE BLADE GUARD

⚠ WARNING! Disconnect the machine from the power source before performing the following steps.

1. Remove the table insert (Fig. 8 - 1) by turning the lock knob (Fig. 8 - 2) 1/4 turn. Lift the insert out of the table (Fig. 9 - 1).
2. Loosen the height adjustment lock knob (Fig. 9 - 3; in the center of the height adjustment handwheel, Fig. 9 - 2). Turn the height adjustment wheel (Fig. 9 - 2) clockwise to raise the saw blade to its maximum height.
3. Move the lock lever (Fig. 10 - 1) up to release the riving knife. Remove the riving knife.
4. Insert the blade guard assembly into the clamp. Ensure the holes in the spreader align with the bumps inside the clamp. Secure the assembly by pressing the lock lever down. Test the clamp by gently pulling up on the assembly. It should stay secured (Fig. 12).
5. To reinstall the riving knife, follow steps 2 and 3 to remove the blade guard assembly. When reinstalling, make sure the riving knife is between 1/8" - 5/16" (3mm - 8mm) from the saw blade (Fig. 11).

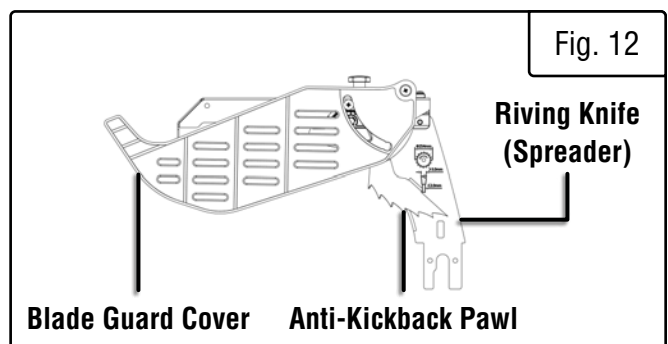
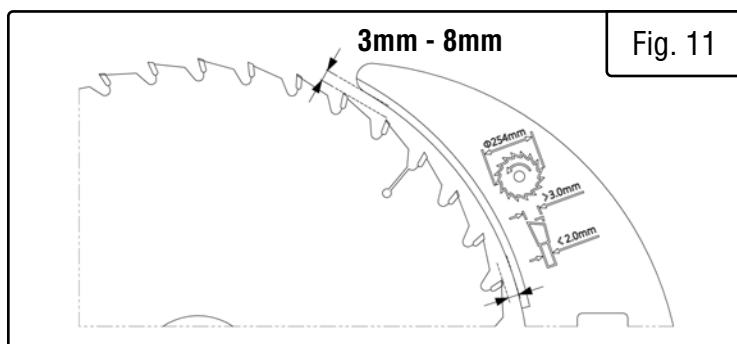
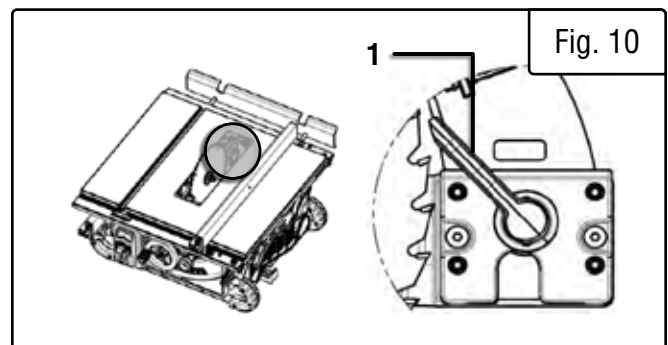
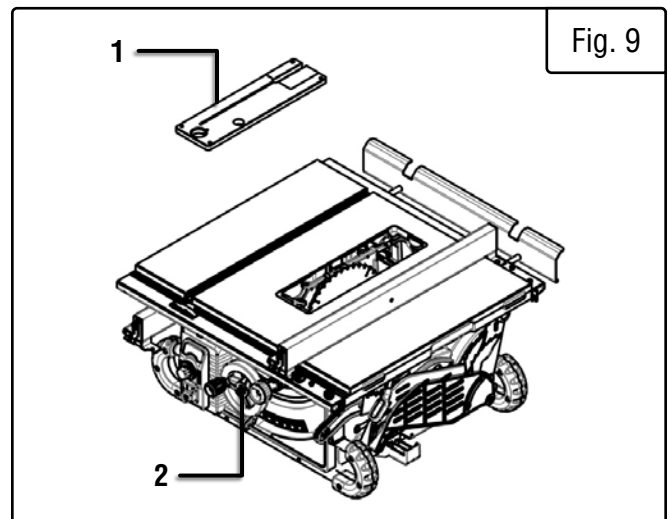
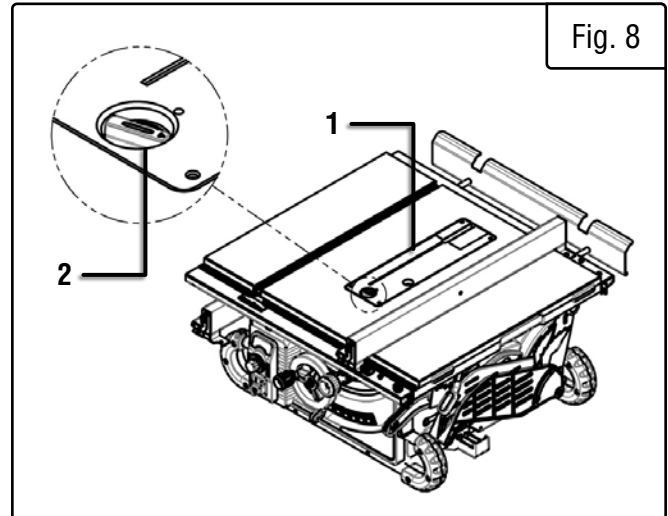

ASSEMBLY

DUST COLLECTION

1. Attach a 2½" dust hose (not included) to the dust port (Fig. 13 - 1).

2. Secure the hose with a hose clamp (not included). Make sure the hose is attached to the dust port tightly.

CAUTION: Always use dust collection when operating the machine. It's safer, less messy, gives better cuts, and helps prolong your machine's life. Failure to use dust collection may void your warranty.

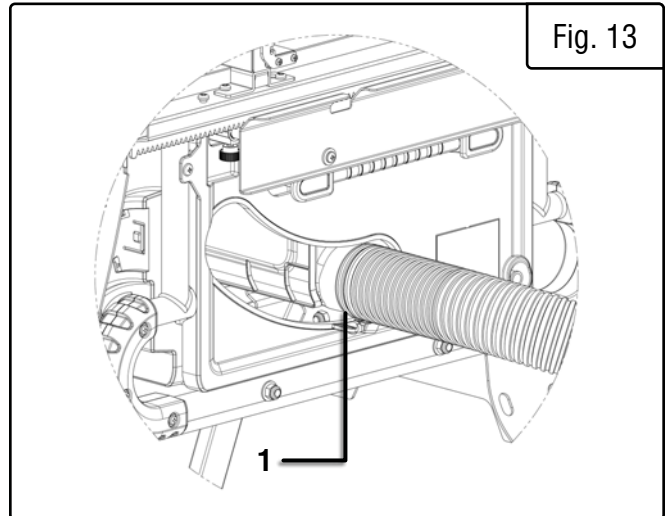

OPERATION

SWITCH ASSEMBLY

This machine is equipped with a magnetic switch to prevent the saw from being damaged by overload. It also includes a red paddle for quick emergency stops, if necessary. Finally, a flip-down tab is provided to prevent unauthorized access to the green ON button (14). Slide a padlock through the sides of the switch housing and the flip-down tab for maximum protection.

CHANGING THE BLADE DEPTH

Loosen the center locking knob, then turn the handwheel clockwise to raise the blade, or counterclockwise to lower the blade. Once the blade is at the desired height, tighten the center locking knob to lock it in place (Fig. 15).

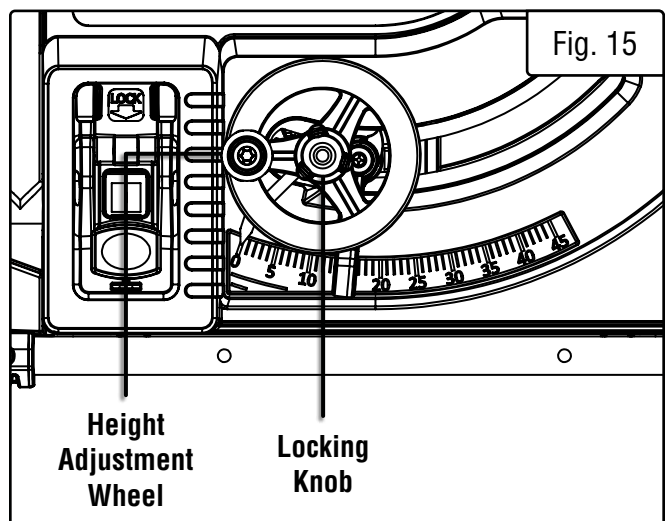
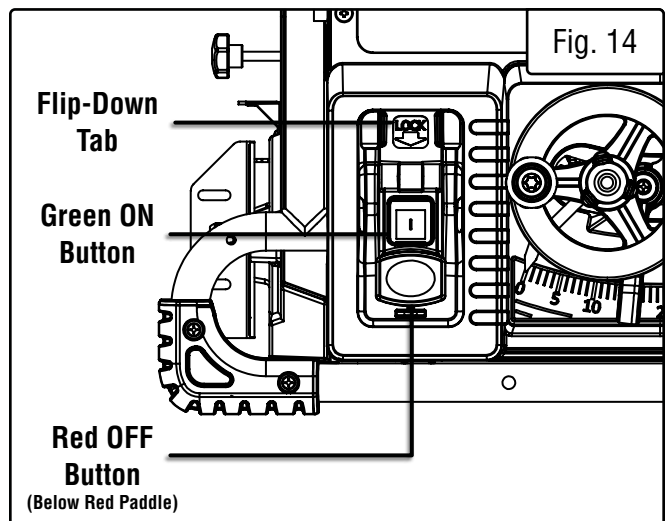

OPERATION

BEVELING THE BLADE

To bevel the blade, move the blade bevel locking lever (Fig. 16 - 1) up to release the locking mechanism. Adjust the blade bevel using the pointer (Fig. 16 - 2) and scale. Once the blade is in the desired position, lock the blade in place by moving the blade bevel locking lever down.

FENCE POSITION

Pull the fence lock lever (Fig. 17 - 2) up to unlock the fence. Turn the fence adjustment knob (Fig. 17 - 1) to move the fence left or right. Push down on the fence lock lever to lock the fence in place.

FENCE SCALE

The fence scale (Fig. 18 - 1) and pointer (Fig. 18 - 2) shows the distance between the blade and the left edge of the fence. The fence scale has two scales - one for the inner fence position, and one for the outer. Ensure that you're referring to the correct scale depending on the fence position.

The fence scale has been calibrated at the factory. However, if you find that you need to make adjustments, unlock the fence, loosen the two fence scale screws (Fig. 18 - 3), adjust the fence as necessary, then tighten the screws and lock the fence down.

AUXILIARY FENCE

This saw comes with an L-shape auxiliary fence (Fig. 19 - 1) for narrow rip cuts. When ripping material 1/8" or thinner, to prevent workpieces from slipping under the fence, the auxiliary fence must be used. Swing the auxiliary fence down toward the blade side of the fence. Figure 20 shows the auxiliary fence in use. When done, replace the auxiliary fence atop the fence, making sure it sits securely on the pin at the end of the fence.

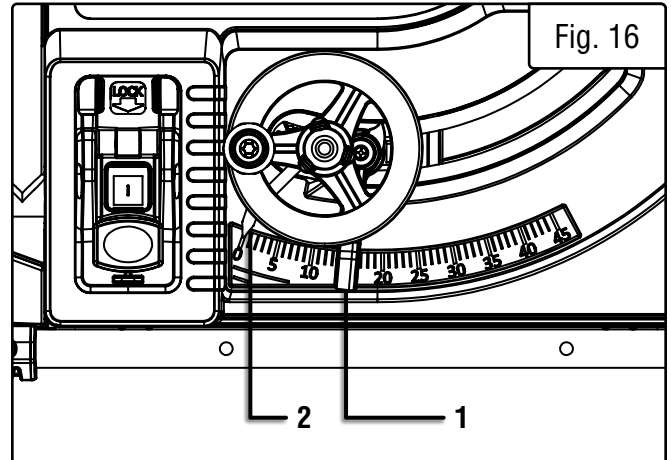

Fig. 16

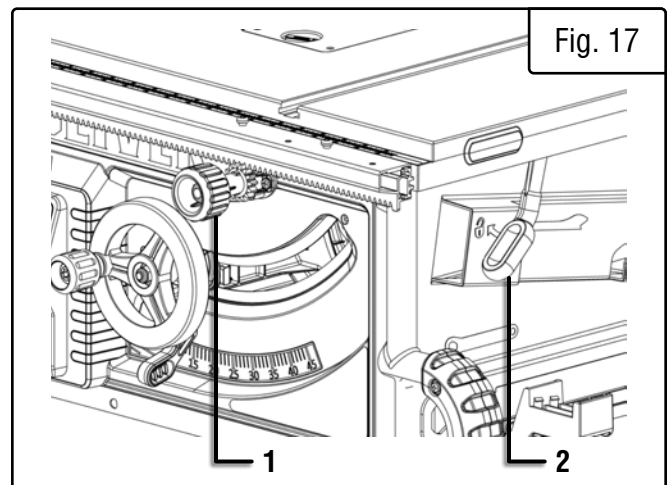

Fig. 17

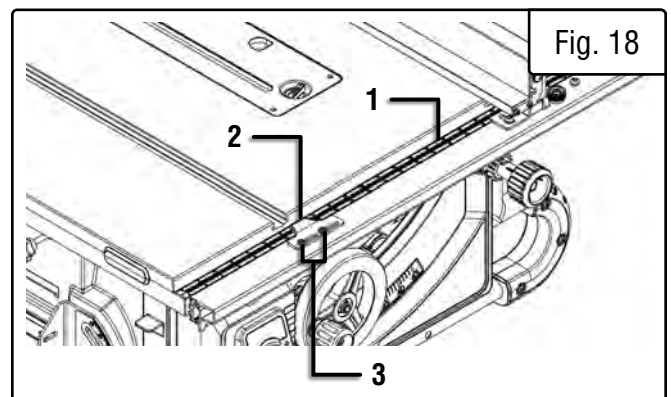

Fig. 18

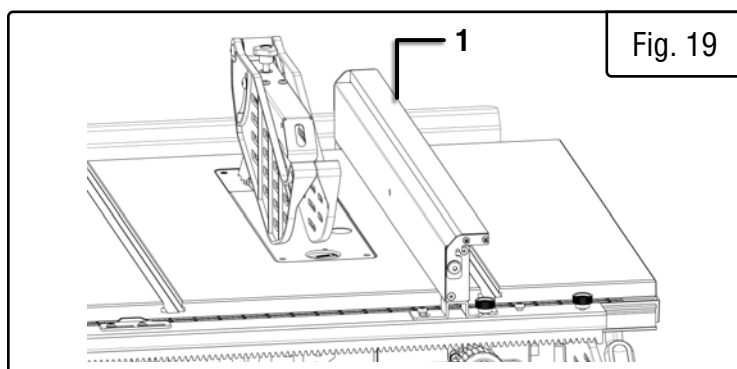

Fig. 19

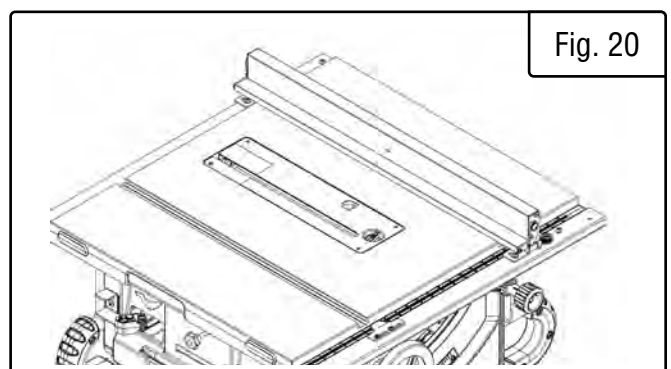

Fig. 20

OPERATION

MITER GAUGE

The miter gauge can be positioned on either side of the blade, as shown in Fig. 21. To change the angle, loosen the knob on the gauge (Fig. 22 - 1) and set it to the desired angle, then tighten the knob.

REAR EXTENSION

When ripping longer workpieces, the rear extension (Fig. 23 - 1) can be extended for extra support. Loosen the two knobs (Fig. 23 - 2) under the rear extension, and pull the extension outward. Then, tighten the knobs to secure the extension.

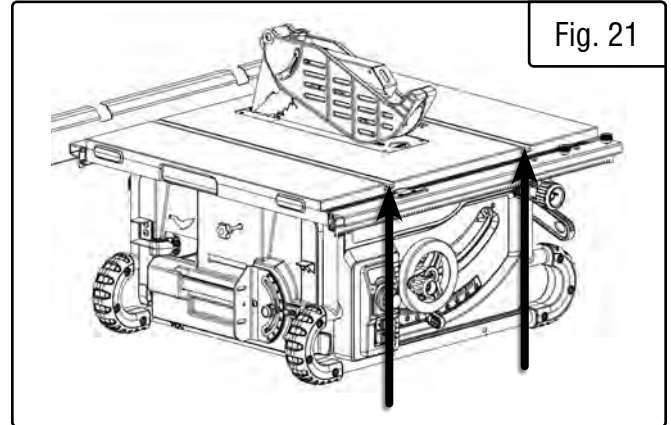

Fig. 21

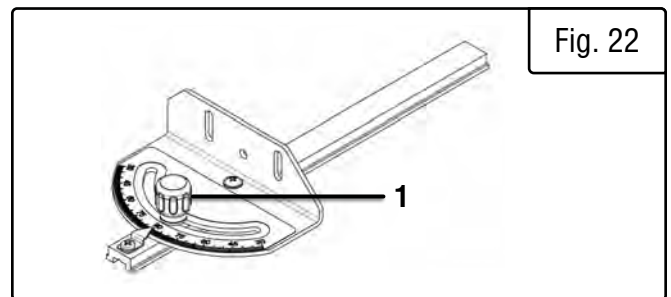

Fig. 22

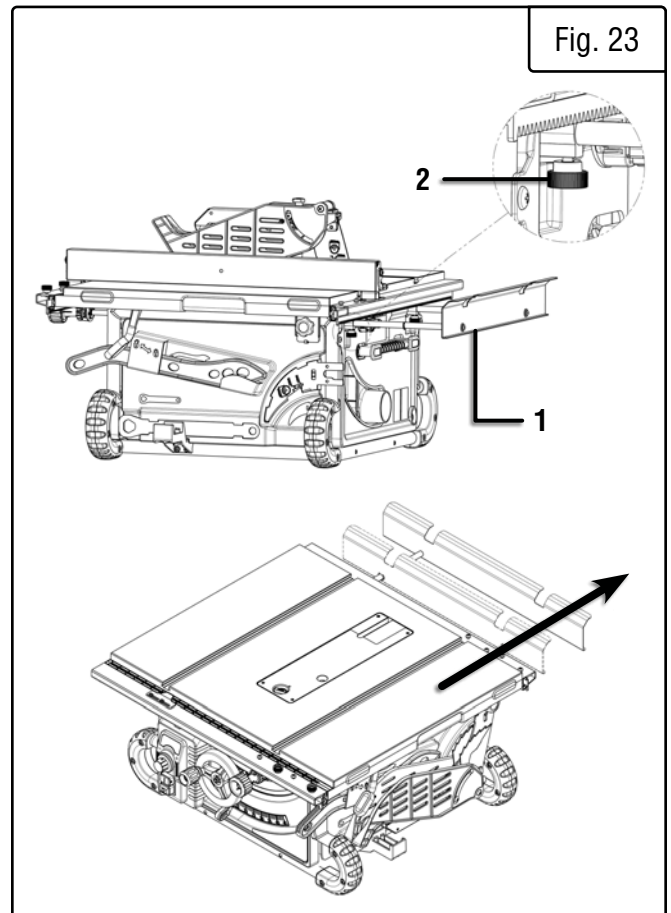

Fig. 23

OPERATION

REPLACING THE SAW BLADE

⚠ WARNING! The blade is very sharp. Wear cut-proof gloves when handling the blade.

1. Remove the blade guard assembly. See page 11.
2. Raise the blade all the way up, and remove the table insert.
3. Push the arbor lock (Fig. 24) in and rotate the blade until it locks in place. This will prevent the blade from turning.
4. While holding the arbor lock (Fig. 25 - 1), use the included arbor wrench or a 23mm combination wrench to loosen and remove the arbor nut (Fig. 25 - 2). Remove the blade flange and the blade.
5. Install the new blade on the arbor, with the directional arrows (Fig. 26 - 1) on the blade matching the arrow on the inside of the blade housing (that is, so the teeth point down at the front of the saw). Install the flange and arbor nut. Securely tighten the nut. (Fig. 26).

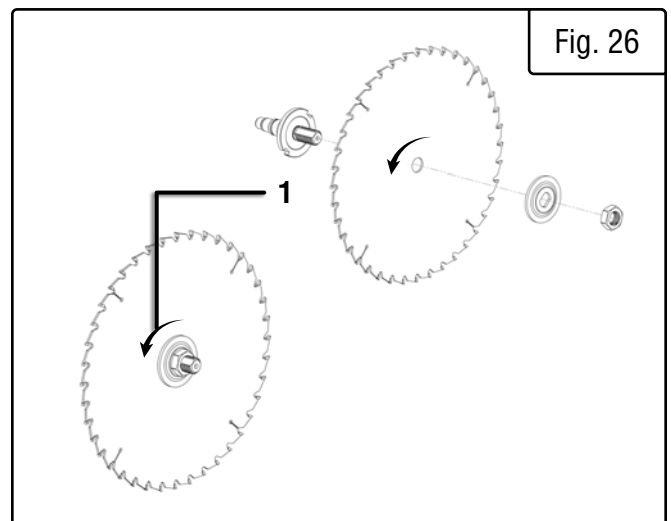
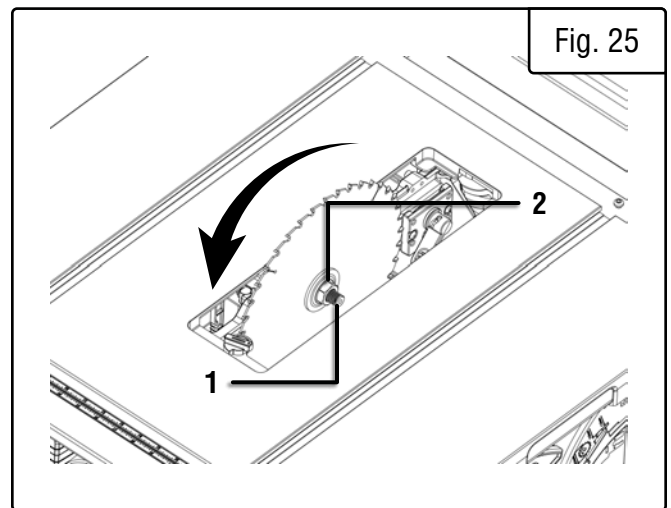
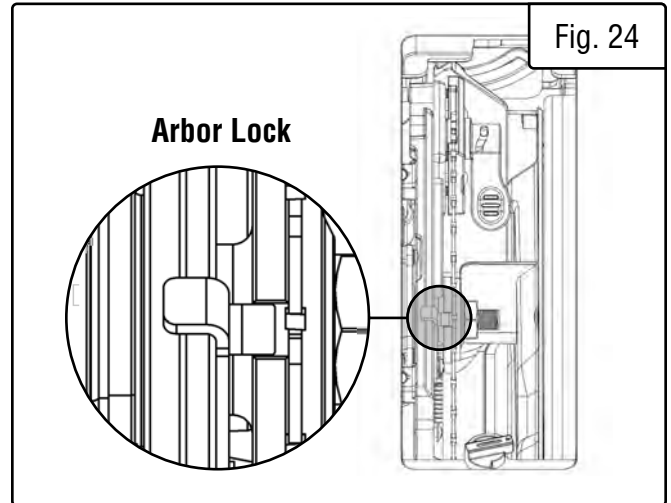

OPERATION

⚠ WARNING! Serious injury can be caused by kickback. Kickback can occur when tension is created between a workpiece sitting against the fence and the blade. This can cause the workpiece to be thrown toward the operator or bystanders. To prevent kickback, review the "SPECIFIC RULES FOR YOUR TABLE SAW" section.

CROSSCUTTING

Crosscutting is to cut a workpiece across its main grain or its width. Follow the steps below to make a cross cut.

⚠ WARNING! Disconnect the machine from the power source before performing the following steps.

1. Remove the fence assembly.
2. Set the blade height 1/8" higher than the top of the workpiece.
3. Set miter gauge to 0° and place it in the desired slot.
4. Hold the workpiece firmly against the miter gauge with the blade path aligned with the desired cutting location. Leave the workpiece at least an inch away from the blade.
5. Connect the machine to power and start the machine, and allow the blade to come up to full speed.

⚠ WARNING! Keep both hands away from the blade and the path of the blade.

6. Keep the workpiece firmly against the face of the miter gauge while holding the workpiece flat against the table.
7. Slowly push the workpiece through the blade until the workpiece is pushed completely past the blade.

⚠ WARNING! Never pull the workpiece while the blade is turning.

8. Turn off the table saw, allow the blade to come to a complete stop, and carefully remove the workpiece.

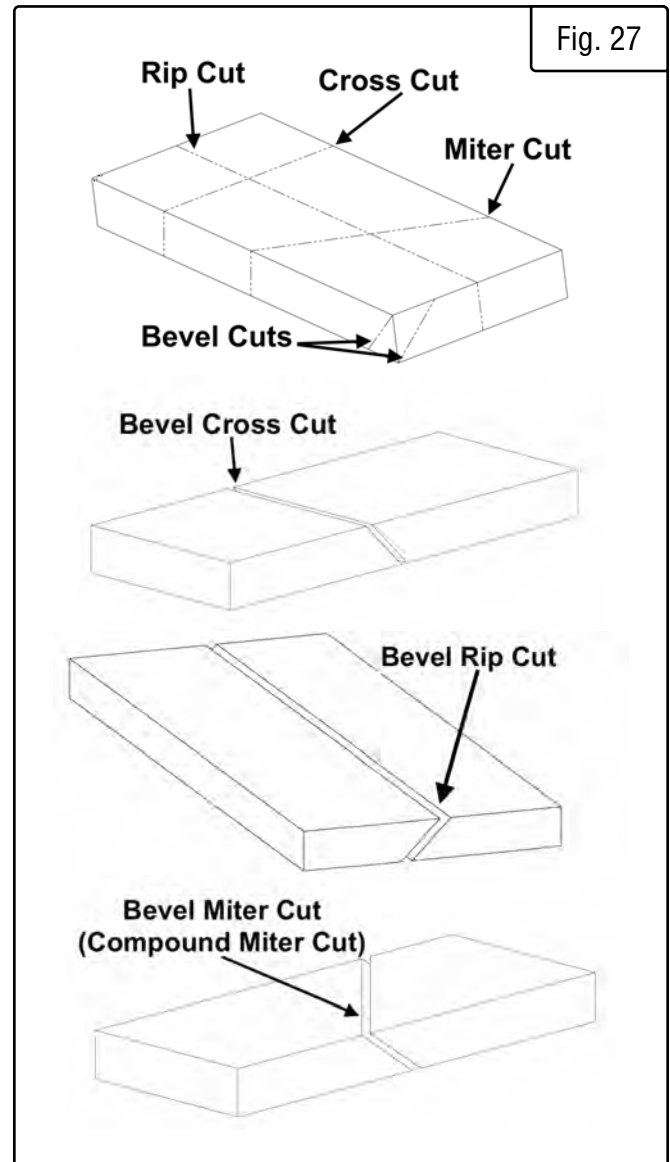

OPERATION

⚠ WARNING! Disconnect the machine from the power source before performing the following steps.

⚠ WARNING! Keep both hands away from the blade and the path of the blade.

BEVEL CROSSCUTTING

Bevel Crosscutting is to cut a workpiece across its main grain or its width with an angle other than 0°. The operation is the same as crosscutting except with an angle. A bevel crosscut is shown in Fig. 28.

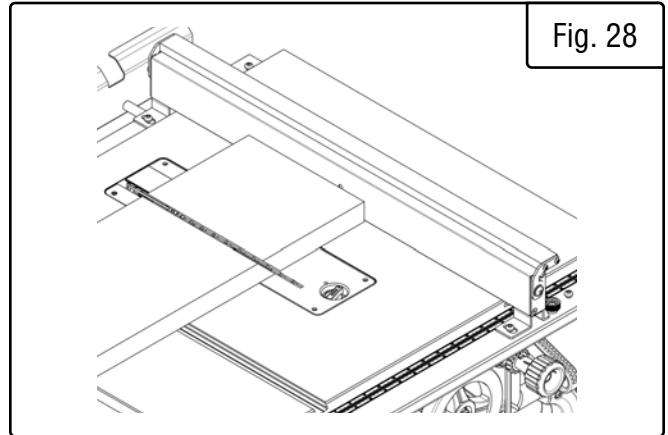

1. Remove the fence assembly.
2. Set blade height 1/8" higher than the top of the workpiece.
3. Set miter gauge to 0° and slide its rail to the desired slot.
4. Tilt the blade to desired angle (see page 17, "BEVELING THE BLADE").
5. Hold the workpiece firmly against the miter gauge with the blade path aligned with the desired cutting location. Leave the workpiece at least an inch away from the blade.
6. Slowly push the workpiece through the blade until the workpiece is pushed completely pass the blade.
7. Turn off the table saw, allow the blade to come to a complete stop, and carefully remove the workpiece.

RIPPING

Ripping is to cut a workpiece along its main grain or its length. Follow the steps below to make a rip cut.

⚠ CAUTION! Workpiece must have a straight edge placed against the fence. **DO NOT** make rip cuts in warped, twisted, or bowed workpieces.

1. Measure the workpiece. If the width of the workpiece is between 2 and 6 inches, use the included push stick to feed the workpiece. If the width of the workpiece is less than 2 inches, use the auxiliary fence.

NOTE: When ripping longer workpieces, use the rear extension for extra support.

2. Remove the miter gauge. Set the fence to the desired cut width and lock the fence in place.
3. Set blade height 1/8" higher than the top of the workpiece.
4. Hold the workpiece firmly against the fence with the blade path in line the desired cutting location. Leave the workpiece at least an inch away from the blade.
5. Have the push stick ready.
6. Plug the saw in and start the saw.
7. Use the push stick to slowly push the workpiece through the blade until the workpiece is completely past the blade.
8. Turn off the table saw, allow the blade to come to a complete stop, and carefully remove the workpiece.

OPERATION

BEVEL RIPPING

Bevel ripping is to cut a workpiece along its main grain or its length with an angle other than 0. This operation is same as ripping, except that the rip cut is at an angle. Follow the steps below to make a bevel rip cut. A bevel rip cut is shown in Fig. 29.

⚠ WARNING! Disconnect the machine from the power source before performing the following steps.

⚠ WARNING! Keep both hands away from the blade and the path of the blade.

⚠ WARNING! Never make cuts narrower than 3/4 inch when bevel ripping to avoid injury.

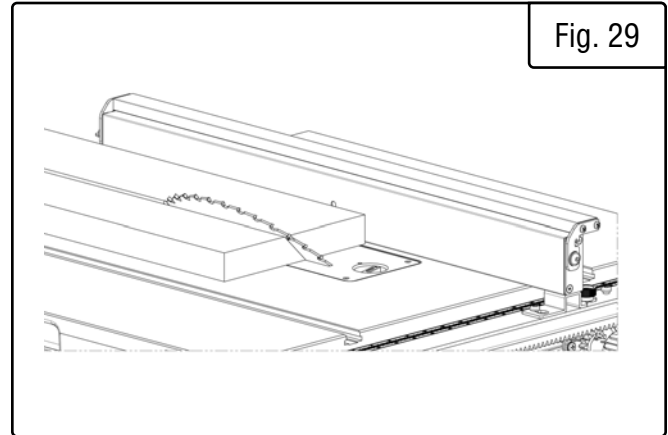

Fig. 29

1. Measure the workpiece. If the width of the workpiece is between 2 and 6 inches, use the included push stick to feed the workpiece. If the width of the workpiece is less than 2 inches, use the auxiliary fence.

NOTE: When ripping longer workpiece, pull the rear extension table for work support.

2. Remove the miter gauge and set the fence to the desired width of cut and lock the fence in place.

3. Set the blade height 1/8" higher than the top of the workpiece.

4. Tilt the blade to the desired angle.

5. Hold the workpiece firmly against the fence with the blade path in line with the desired cutting location. Leave the workpiece at least an inch away from the blade.

6. Have the push stick ready.

7. Plug the saw in and start the saw.

8. Use the push stick to slowly push the workpiece through the blade until the workpiece is completely past the blade.

9. Turn off the table saw, allow the blade to come to a complete stop, and carefully remove the workpiece.

OPERATION

MITERING

A miter cut is the same operation as crosscut except the miter gauge is set at an angle other than 90°.

1. Remove the fence.
2. Set the blade at 0 bevel angle (see page 17, "BEVELING THE BLADE").
3. Set the miter gauge at the desired angle (see page 18, "MITER GAUGE").
4. Raise the blade 1/8" higher than the top of the workpiece.
5. Hold the workpiece firmly against the miter gauge. Leave the workpiece at least an inch away from the blade.
6. Connect the machine to power, start the machine, and allow the blade to come to full speed.
7. Keep the workpiece firmly against the face of the miter gauge while holding the workpiece flat against the table.
8. Slowly push the workpiece through the blade until the workpiece is pushed completely past the blade.
9. Turn off the table saw, allow the blade to come to a complete stop, and carefully remove the workpiece.

⚠ WARNING! Disconnect the machine from the power source before performing the following steps.

⚠ WARNING! Keep both hands away from the blade and the path of the blade.

BEVEL MITERING

A bevel miter cut, also called a compound miter cut, is a combination of bevel crosscutting and mitering. Follow the instructions for both bevel crosscutting and mitering (Fig. 30).

NON-THROUGH CUTTING

A non-through cut is when the saw blade does not cut through the workpiece. Dado cuts, rabbet, and grooves are non-through cuts. Non-through cuts are the only type of cuts for which the blade guard assembly must be removed. It has higher risk of kickback.

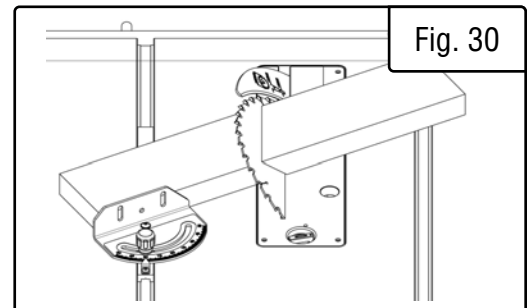

⚠ WARNING! Serious injury can be caused by kickback. Kickback can occur when tension is created between a workpiece sitting against the fence and the blade. This can cause the workpiece to be thrown toward the operator or bystanders. To prevent kickback, review the "SPECIFIC RULES FOR YOUR TABLE SAW" section.

1. Adjust the bevel angle to 0°.
2. Remove blade guard assembly. Install the riving knife (See page 15, "INSTALLING THE BLADE GUARD").
3. Set the blade to the desired depth.
4. Use either the fence or miter gauge, depending on the size of the workpiece and type of cut (e.g. crosscut, rip cut, etc.).
5. Hold workpiece firmly against fence or miter gauge. Leave the workpiece at least an inch away from the blade.
6. Connect the machine to power, start the machine, and allow the blade to come to full speed.

OPERATION

NON-THROUGH CUTTING (CONT.)

7. Slowly push the workpiece through the blade with the push stick (included), push blocks (not included), and/or feather board (not included) until the workpiece is pushed completely past the blade.
8. Turn off the table saw, allow the blade to come to a complete stop, and carefully slide the workpiece out.
9. Immediately reinstall the blade guard assembly on the saw.

DADO CUTTING

A dado cut is similar to a non-through cut, in which multiple cuts are performed in succession to create a slot in the workpiece, called a dado. Refer to and follow the instructions in "Non-Through Cutting" on this and the previous page.

Specialized dado blades are also available as aftermarket accessories, as are specialized throat plates compatible with such dado blades. WEN offers a dado blade set (**model BL088D**) and dado throat plate (**model TT1015-DADO**), available for purchase at wenproducts.com.

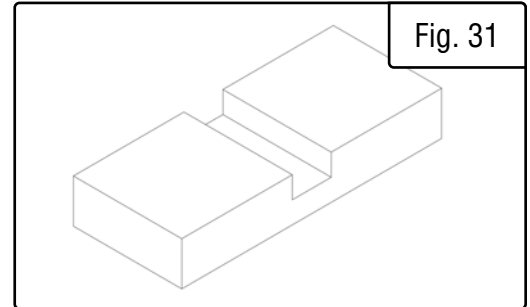

⚠ CAUTION! Use extreme caution when dado cutting. Always check dado blade clearance before connecting the saw to a power source.

⚠ CAUTION! Do not stack dado blades thicker than the maximum capacity of 13/16". Do not use dado blades larger than 8" in diameter.

⚠ CAUTION! Follow all instructions included in your dado blade's owner's manual. Failure to do so could result in serious injury to yourself or others.

⚠ WARNING! Do not use a dado blade set without a special dado throat plate installed! The throat plate included with your saw is NOT compatible with dado blades.

SAFETY CUTTING ACCESSORIES

Safety cutting accessories for this table saw include the following: push stick (included), push blocks (not included), and/or feather board (not included).

DUST COLLECTION

This table saw is equipped with a 2 ½" dust collection port. Connect a dust collector to the port at the rear of the saw (See "DUST COLLECTION" section on page 16).

ADJUSTMENTS

RIVING KNIFE & SAW BLADE ALIGNMENT

⚠ WARNING! Disconnect the machine from the power source before performing the following steps.

The riving knife and saw blade alignment has been adjusted at the factory. In most cases, there should not be adjustments needed. However, the riving knife and spreader in the blade guard assembly must be aligned with saw blade during installation.

⚠ WARNING! Riving knife and saw blade must align in order to reduce the risk of kickback during operation.

1. Remove blade guard assembly (See page 17, "INSTALLING THE BLADE GUARD").

2. Remove table insert.

3. Raise saw blade to its maximum height.

4. Set the bevel to 0° angle.

5. Place a straightedge against the blade and riving knife (Fig. 32), first on the bottom of the riving knife, then the top, to ensure both components are parallel and aligned (Fig. 33).

6. If the riving knife is parallel and aligned with the saw blade, no adjustment is needed. If not, continue to step 7.

7. If either the top or bottom is not aligned, remove the riving knife and place it on a flat surface to see if the riving knife is bent.

8. If the riving knife is bent, straighten it manually. If it can't be straightened, call **1-800-232-1195** to order a replacement.

9. If the issue is not a bent riving knife, adjust the screws on the riving knife block as shown in Fig. 34. Use a 3mm hex wrench to loosen the 2 cap screws (Fig. 34 - A). Then use the hex wrench to adjust the 2 top set screws (Fig. 34 - B) for top alignment adjustments, or the bottom set screws (Fig. 34 - C) for bottom alignment adjustments.

10. To move the knife back or forth, adjust 1 top and 1 bottom set screw on the same side. Do the same for the opposite side. Make sure the riving knife is between 1/8" - 5/16" (3 - 8mm) away from the blade teeth at all points (Fig. 33). Do the same for the opposite side.

11. Tighten the cap screws to secure the knife in place.

12. Repeat steps 3 - 6 to ensure the blade and riving knife are aligned. Adjust as needed. Once the blade and riving knife are aligned, remove the riving knife.

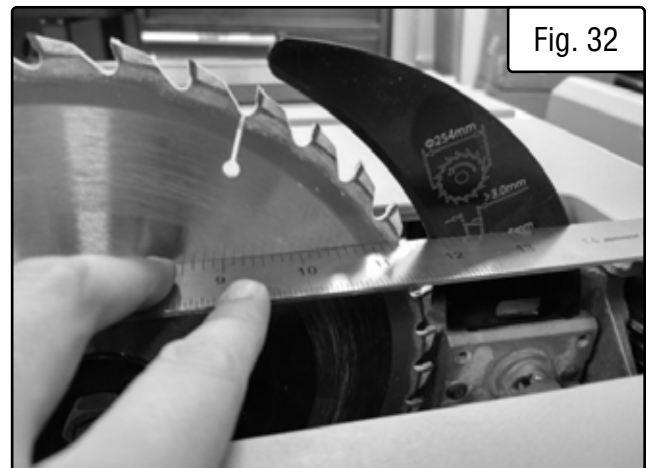

Fig. 32

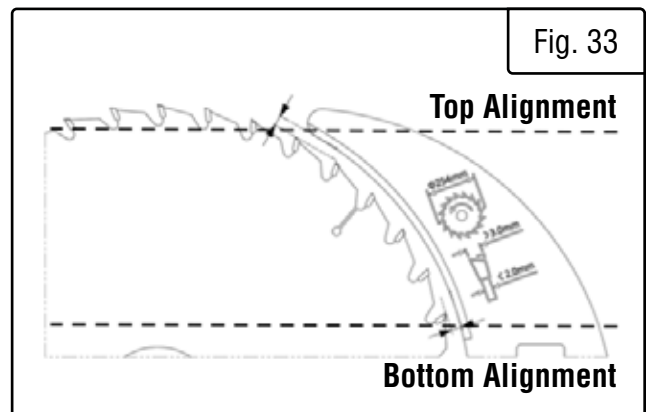

Fig. 33

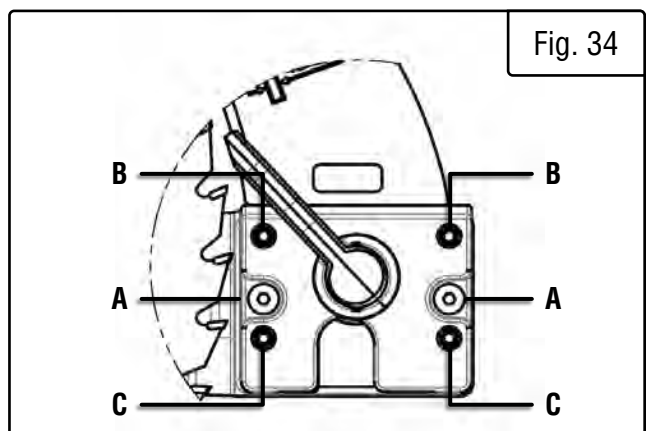

Fig. 34

ADJUSTMENTS

RIVING KNIFE & SAW BLADE ALIGNMENT (CONT.)

13. Reinstall the table insert.

14. Reinstall the blade guard assembly.

FENCE AND SAW BLADE ALIGNMENT

⚠ WARNING! Disconnect the machine from the power source before performing the following steps.

⚠ WARNING! Fence and saw blade must align in order to reduce the risk of kickback during operation.

1. Remove the blade guard (See "INSTALLING THE BLADE GUARD" on page 15).
2. Raise saw blade to its maximum height.
3. Set the bevel to 0° angle.
4. Slide the fence over until it contacts the saw blade (Fig. 35).
5. Check to see if they are parallel to each other. If they are not, continue to step 6.
6. Use a 4mm hex wrench to loosen the screws on the fence knob bracket (Fig. 36). Adjust the bracket until the fence and blade are parallel, then tighten the screws.
7. Once adjustment is done, reinstall the blade guard.

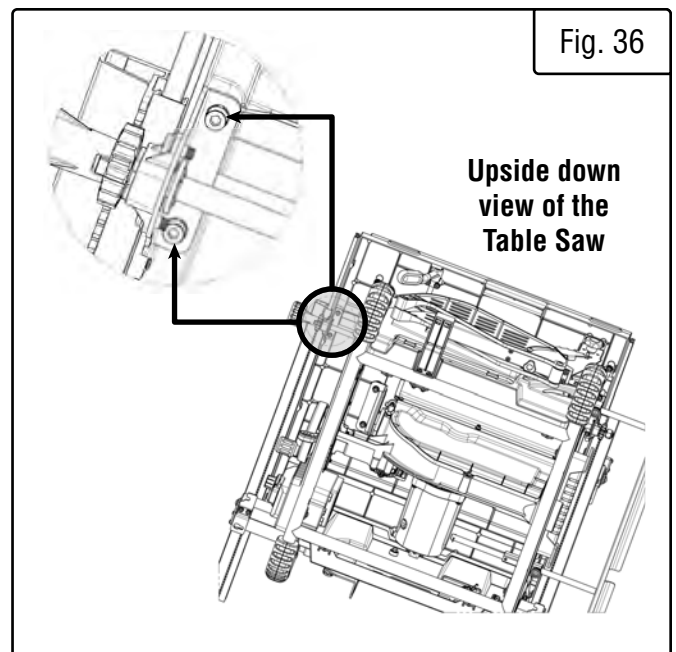
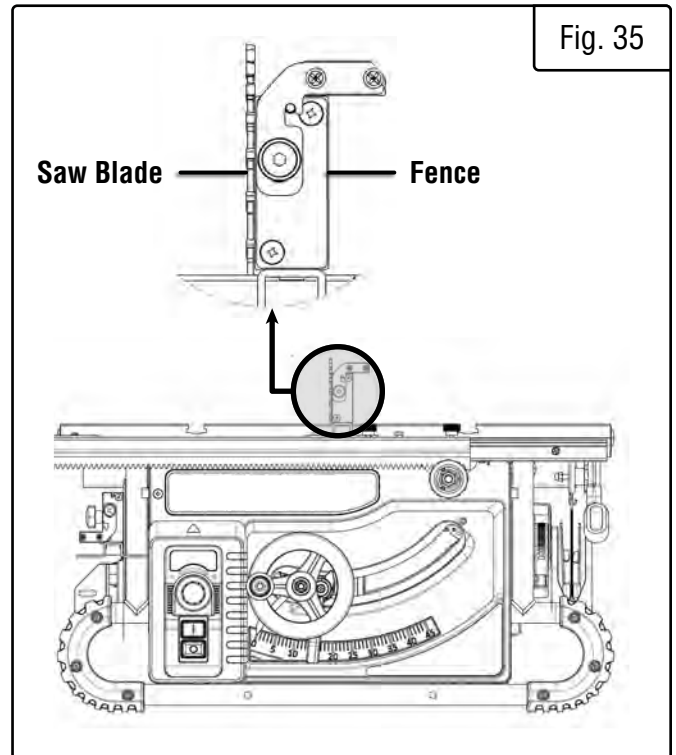

ADJUSTMENTS

MITER GAUGE SLOT AND BLADE ALIGNMENT

For the best results, the miter slot should be adjusted parallel to the blade. This is done at the factory, but if it is not exactly parallel, follow the steps below to reduce the risk of kickback.

⚠ WARNING! Disconnect the machine from the power source before performing the following steps.

1. Remove the blade guard (See "INSTALLING THE BLADE GUARD" on page 15).
2. Raise saw blade to its maximum height.
3. Set the bevel to 0° angle.
4. Use an adjustable square (not included) to measure the distance from the miter slot to a carbide tip on the blade (Fig. 37). Make sure that the face of the adjustable square is even along the miter slot.
5. With the end of the adjustable square just touching the tip, lock the square in place. Mark the carbide tip with a marker (not included) where you made this measurement.
6. Rotate the marked blade tip to the other end of the table insert.
7. Slide the adjustable square down to the other end of the table insert, and compare the distance from the marked blade tip to the end of the adjustable square.
 - If the blade tip measurement is the same on both sides, the miter slot is parallel with the table; the procedure is complete.
 - If the blade tip measurement is not the same on both sides, the table will need to be adjusted. Proceed to step 8.
8. To adjust the table, slightly loosen the cap screws in the trunnion mounting locations (Fig. 38) and slightly tap the trunnions in the needed direction. Repeat steps 2 through 5 until the blade and miter slot are parallel.
9. Tighten the trunnion mounting cap screws.

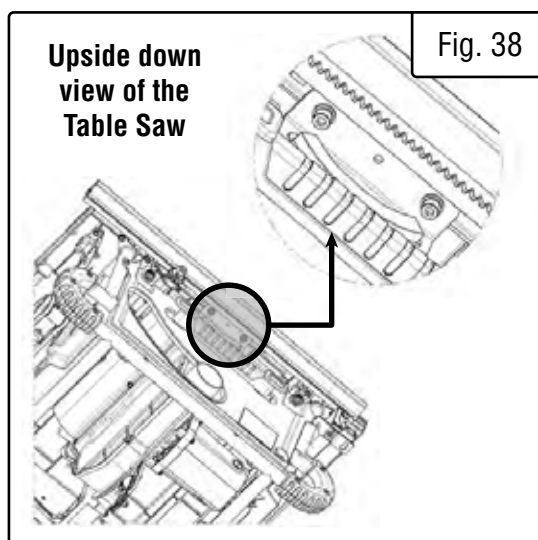
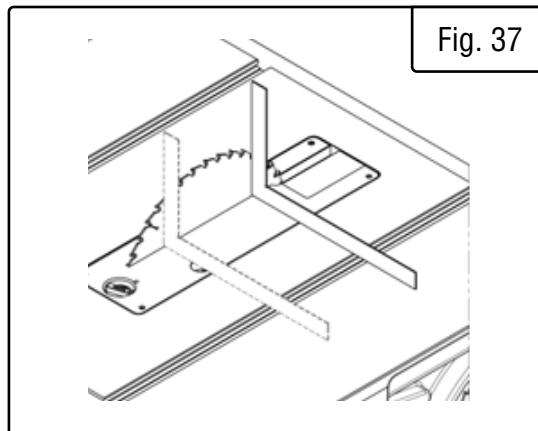

ADJUSTMENTS

BEVEL STOP ADJUSTMENT

The bevel stops have been set at the factory, and should not require adjustments. However, if your cuts are noticeably inaccurate, follow the steps below to adjust the bevel.

⚠ WARNING! Disconnect the machine from the power source before performing the following steps.

1. Remove the blade guard or riving knife (See "INSTALLING THE BLADE GUARD" on page 15).
2. Raise saw blade to its maximum height.

To check 90° bevel:

3. Set the bevel to a 0° angle. When the bevel is at 0°, the blade is at 90°.
4. Place a 90° square between the table and blade to set the blade at 90° (Fig. 39). Make sure the square contacts the top and bottom of the blade evenly.
5. If the blade is at 90° and the indicator points to 0 degrees, no further adjustment is needed. If not, go to the next step.
6. Loosen the bevel cam's adjustment screw (Fig. 40).
7. Use the tip of a screwdriver to rotate the cam's adjustment holes up or down as necessary. Rotate it up to move the bevel stop left; rotating down moves it right. Use the square on the table as a reference.
9. Tighten the adjustment screw to secure the bevel cam.
10. Check the square to make sure the adjustment is complete. If not, repeat steps 4 through 10.
11. Reinstall the blade guard assembly or riving knife.

To check 45° bevel:

3. Set the bevel to 45° angle.
4. Place a 45° triangle square between the table and blade to set the blade at 45° (Fig. 41).
5. If the blade is at 45° to the table and the pointer is pointing at 45 on the scale, no further adjustment is needed. If not, go to the next step.
6. Follow the same steps as adjusting the 90 degree bevel cam, using the 45 degree bevel cam.

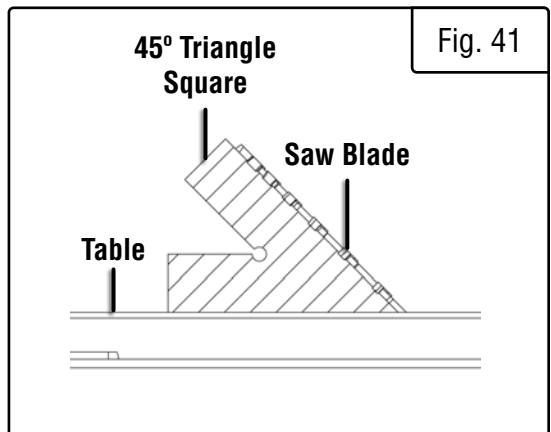
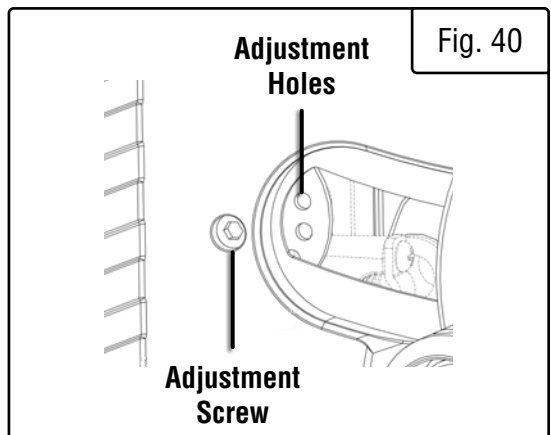
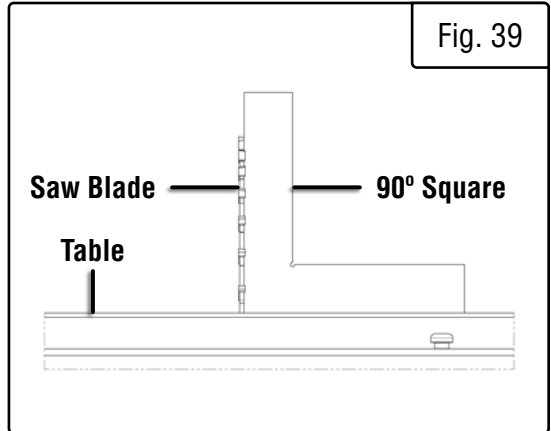

ADJUSTMENTS

LEVELING TABLE INSERT

The table insert must sit flush with the table in order to provide a smooth surface to slide the finished workpiece on. To check and adjust the table insert, follow the steps below.

⚠ WARNING! Disconnect the machine from the power source before performing the following steps.

1. Remove the blade guard (See page 15 for instructions).
2. Place a straight edge on the table insert (Fig. 42). Be sure to check in both the lengthwise and widthwise directions.
3. If the table insert is flush with the table, no adjustment is needed. If not, go to step 4.
4. Use a 2.5mm hex wrench to loosen or tighten leveling screws (Fig. 42). Loosening screws lowers the insert; tightening screws raises it.

FENCE SCALE ADJUSTMENT

The fence scale shows the dimensions of finished cuts. If your cuts do not match the scale, follow the steps below.

1. Raise saw blade to its maximum height.
2. Place the fence on the right side of the blade and slide it toward the blade until the fence just touches the saw blade teeth.

NOTE: Do not push too hard or the blade might deflect.

3. Look at the scale pointer. If the pointer reads 0, no adjustment is needed. If not, go to the next step.
4. Use a Phillips-head screwdriver (not included) to loosen the two screws on the pointer, shown in Fig. 43. Slide the pointer until 0 is shown, then tighten the screws. Then, tighten the screws.

NOTE: When using the auxiliary fence, you may want to reset the pointer. Slide the auxiliary fence against the blade tips, and set the pointer to an easy-to-remember number, such as 1". When making a cut, add 1" to your desired final measurement (e.g. if making a 3.5" cut, set the scale to 4.5"). Do not forget to reset the pointer when the auxiliary fence is no longer needed.

MITER GAUGE

If the angle set on the miter gauge appears to be inaccurate, the gauge's rail and plate may be misaligned. Follow the steps below to adjust the miter gauge.

1. Use a Phillips-head screwdriver (not included) to loosen the screw (Fig. 44). Place a square between the rail and plate. Adjust the plate as needed, then tighten the screw.
2. When the rail and plate are at 90 degrees to one another, tighten the screw.

NOTE: If the pointer is inaccurate, loosen the pointer mounting screw (Fig. 44) with the screwdriver, adjust the pointer, and tighten the screw.

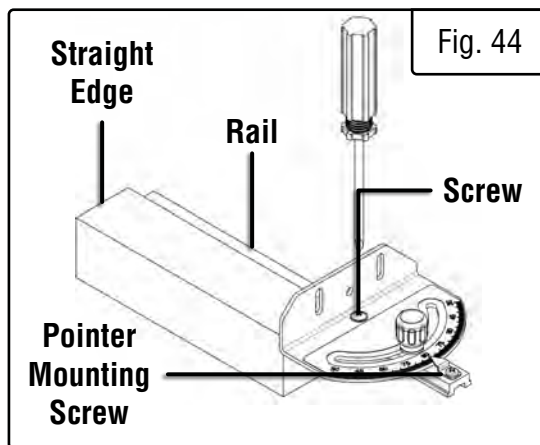
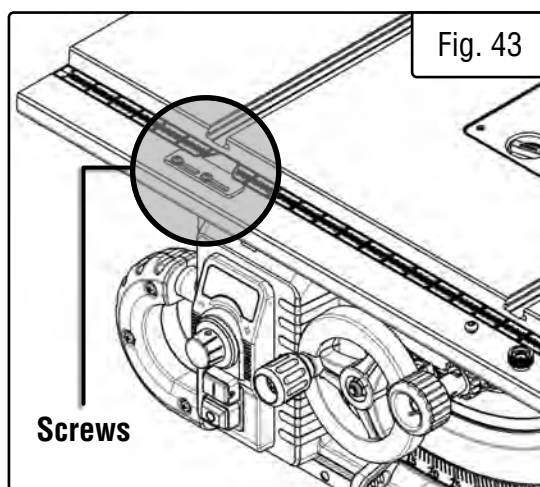
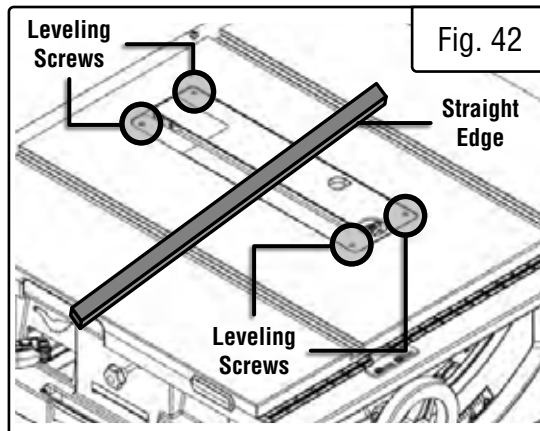

MAINTENANCE

 **WARNING!** To avoid accidents, turn OFF and unplug the tool from the electrical outlet before cleaning, adjusting, or performing any maintenance work.

 **WARNING!** Any attempt to repair or replace electrical parts on this tool may be hazardous. Servicing of the tool must be performed by a qualified technician. When servicing, use only identical WEN replacement parts. Use of other parts may be hazardous or induce product failure.

ROUTINE INSPECTION

Before each use, inspect the general condition of the tool. If any of these following conditions exist, do not use until parts are replaced or the sharpener is properly repaired.

Check for:

- Loose hardware,
- Misalignment or binding of moving parts,
- Damaged cord/electrical wiring,
- Cracked or broken parts, and
- Any other condition that may affect its safe operation

CLEANING

1. Keep the ventilation openings free from dust and debris to prevent the motor from overheating.
2. Periodically clean the inside of the machine for dust control. Use compressed air (not exceeding 25 PSI) to blow out dust from the motor housing and blade housing.
3. Wipe the tool surfaces clean with a clean cloth. Make sure water does not get into the tool.
4. Every 6 months, use a wire brush to clean dust off the trunnions, gears, blade elevation and fence / rail mechanism and apply a dry lubricant, such as PTFE, to these parts. **NOTE:** Applying a wet lubricant (e.g. grease, etc.) can cause sawdust and wood chips to become trapped, decreasing the life of these components.

CARBON BRUSH REPLACEMENT

Replacement carbon brushes (**Part No. TT1015-035.14**) can be ordered at wenproducts.com. Only genuine WEN replacement brushes designed specifically for your tool should be used. Carbon brushes are not covered under the two-year warranty.

1. The carbon brush caps can be accessed on either side of the motor housing.
2. Carefully remove the old carbon brushes using pliers.
3. Install the new carbon brushes. Both carbon brushes should be replaced at the same time.

NOTE: New carbon brushes tend to spark for a few minutes during the first use as they wear down.

MAINTENANCE

STORAGE

1. Store the tool in a clean and dry place away from the reach of children. Store in temperatures between 41° to 86°F.
2. Cover the table saw in order to protect it from dust and moisture. It is preferable to store it in its original packaging with the instruction manual.

Accessory Storage

You can store your saw's accessories on the saw for maximum convenience.

The power cord can be wrapped around the cord clip at the back of the saw (Fig. 45).

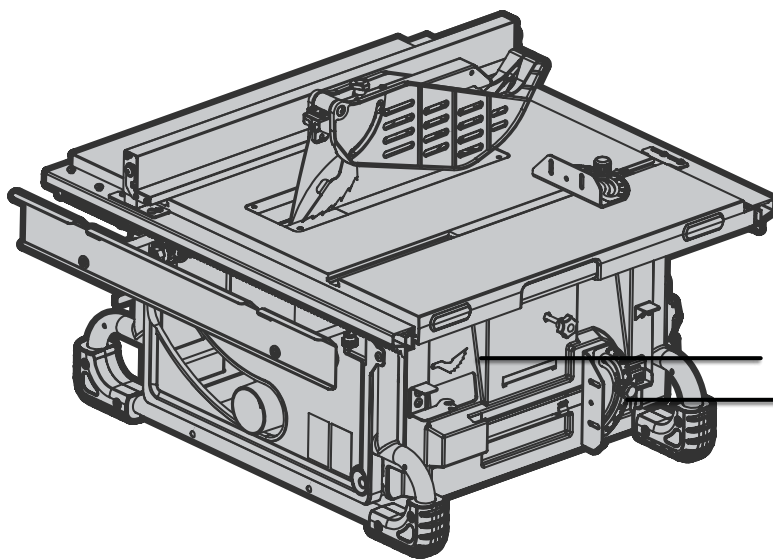
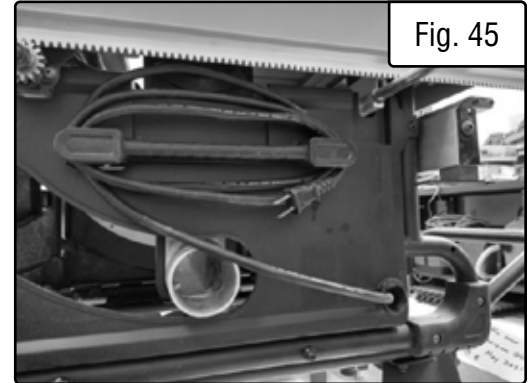

The miter gauge and fence are stored on the left side of the saw, as shown on page 14.

NOTE: A space is also provided for the anti-kickback pawls, in case you ever need to remove them from the blade guard assembly.

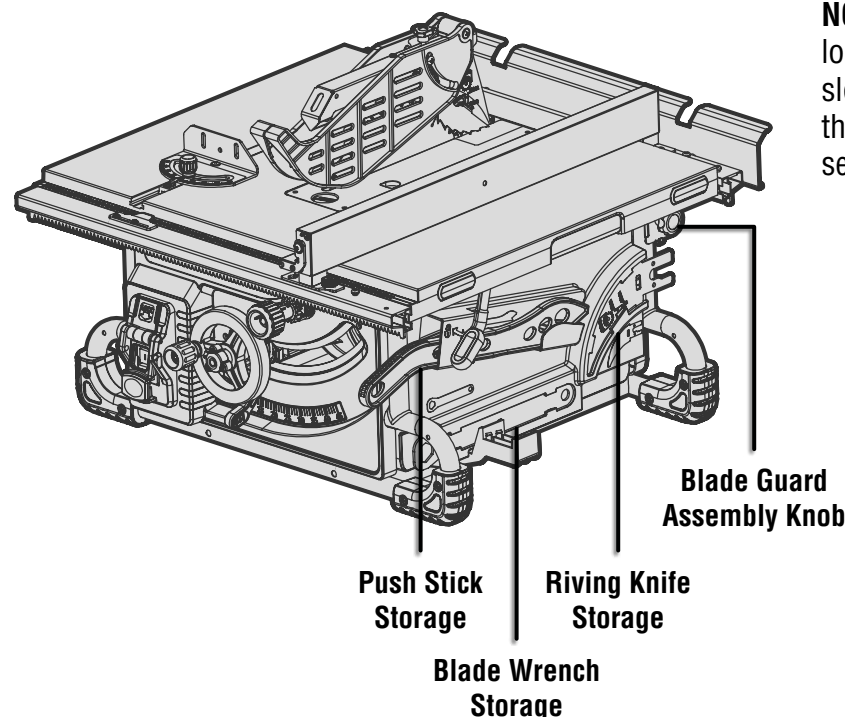

The blade wrench, riving knife, blade guard assembly, and push stick are stored on the right side of the saw, as shown below.

NOTE: When storing the blade guard assembly, loosen the knob shown in figure 46. Place the slot in the blade guard spreader over the tab on the mounting bracket, then tighten the knob to secure the assembly.

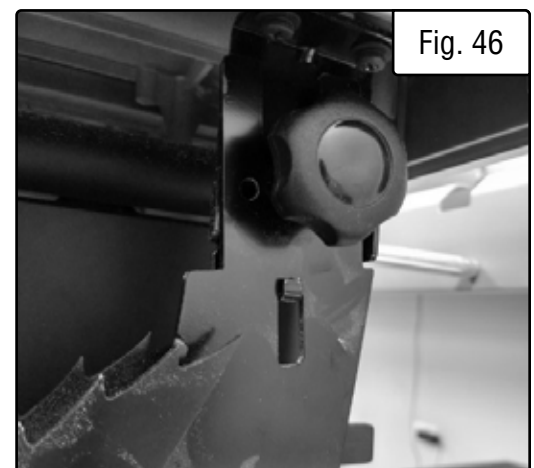

TROUBLESHOOTING GUIDE

⚠ WARNING! Stop using the tool immediately if any of the following problems occur. Repairs and replacements should only be performed by an authorized technician. For any questions, please contact our customer service at **1-(800) 232-1195**, M-F 8-5 CST or email us at **techsupport@wenproducts.com**.

PROBLEM	CAUSE	SOLUTION
Machine will not start.	1. Not plugged in.	1. Check connection.
	2. Wrong size of extension cord.	2. Consult extension cord chart on p. 10.
	3. Worn carbon brushes.	3. Replace carbon brushes.
	4. Faulty power cord, motor, or switch.	4. Consult WEN customer service at 1(800) 232-1195 .
Blade does not come up to speed.	1. Blade arbor nut not tightened.	1. Tighten blade arbor nut.
Does not make accurate 45° or 90° cuts.	1. Bevel stops not adjusted correctly.	1. Check blade with combination square and adjust stops.
	2. Angle pointer not set accurately.	2. Check blade with combination square and adjust pointer.
	3. Fence is not properly aligned.	3. Adjust fence.
Saw makes unsatisfactory cuts.	1. Dull Blade.	1. Sharpen or replace blade.
	2. Blade mounted backwards.	2. Turn blade around.
	3. Gum or pitch on blade.	3. Remove blade and clean.
	4. Incorrect blade for cut.	4. Change blade to correct type.
Material binds blade when ripping.	1. Fence not aligned with blade.	1. Check and adjust fence.
	2. Warped wood.	2. Select another piece of wood.
	3. Excessive feed rate.	3. Reduce feed rate.
	4. Riving knife or blade guard not aligned with blade.	4. Align riving knife or blade guard with blade.

EXPLODED VIEW & PARTS LIST

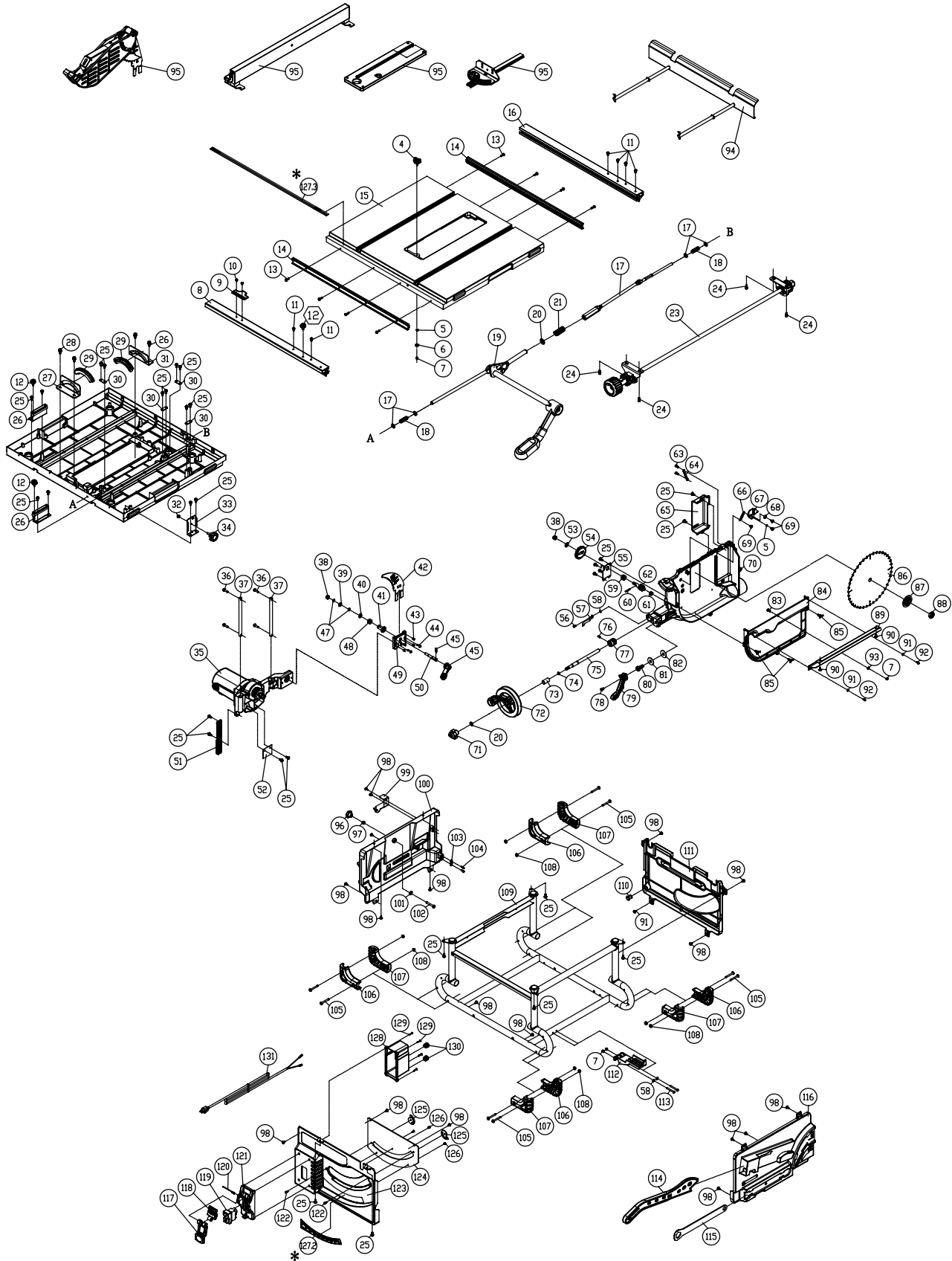

NOTE: Not all parts may be available for purchase. Parts and accessories that wear down over the course of normal use are not covered under the warranty.

EXPLODED VIEW & PARTS LIST

No.	Part No.	Description	Qty.
1	TT1015-001ASM	Blade Guard Assembly	1
2	TT1015-002ASM	Fence Assembly	1
3	TT1015-003	Table Insert Assembly	1
4		Table Insert Locking Knob	1
5		6mm Wavy Washer	1
6		6mm Flat Washer	1
7		Lock Nut, M5	1
8		Front Rail	1
9		Fence Scale Pointer	1
10		Phillips Head Screw with Flat Washer, M4-0.7x8	2
11		Socket Button Head Cap Screw, M5x3	6
12		Fence Lock Knob, M5x12	2
13		Phillips Head Screw with Spring Washer, M5-0.8x16	8
14		Rail Mounting Bar	2
15		Table	1
16		Back Rail	1
17		8mm Flat Washer	4
18		Spring	2
19		Fence Lock Assembly	1
20		9mm Flat Washer	2
21		Spring	1
22		Rear Fence Lock Shaft	1
23		Rail Adjustment Rod Assembly	1

No.	Part No.	Description	Qty.
24		Socket Head Cap Screw with Lock Washer & Flat Washer, M5x12	4
25		Phillips Head Screw with Lock Washer & Flat Washer, M5x14	12
26		Extension Table Bracket	2
27		Rear Trunnion Bracket	1
28		Socket Head Cap Screw with Lock Washer & Flat Washer, M6x15	4
29		Trunnion Bushing	2
30		Cord Clamp	4
31		Front Trunnion Bracket	1
32		Acorn Nut, M6	1
33		Blade Guard Storage Bracket	1
34		Blade Guard Locking Knob, M6x25	1
35		Motor & Gearbox Assembly	1
N.P.	TT1015-035.14	Carbon Brush	2
36		Pan Head Phillips Screw with Flat Washer and Lock Washer, M5x22	4
37		Gearbox Support Rod	2
38		Lock Nut, M8	2
39		9mm Flat Washer	1
40		S Ring STW-14	1
41		Bushing	1
42	TT1015-042	Riving Knife	1
43		Set Screw, M6x8	4

EXPLODED VIEW & PARTS LIST

No.	Part No.	Description	Qty.
44		Socket Button Head Cap Screw, M5x20	2
45		Alignment Pin	1
46		Locking Handle	1
47		Wavy Washer, 8mm	2
48		Spring	1
49		Riving Knife Locking Plate	1
50		Locking Bolt	1
51		Elevation Rack	1
52		Lower Guard Plate	1
53		9mm Flat Washer	1
54		Elevation Gear	1
55		Elevation Gearbox Cover	1
56		Cap Screw, M4x8	1
57		Scale Indicator	1
58		Toothed Washer, 4mm	1
59		Gear Box Cover Bushing	1
60		Spring Pin, 4x25mm	1
61		Bushing	1
62		Worm Gear	1
63		Cap Screw, M5x10	2
64		Spring	1
65		Rear Cover	1
66		Spindle Lock Spring	1
67		Spindle Lock	1
68		7mm Flat Washer	1
69		Shoulder Screw	3
70		Trunnion	1
71		Elevation Lock Knob	1

No.	Part No.	Description	Qty.
72		Elevation Handwheel	1
73		Bushing	1
74		O-ring, P9	1
75		Elevation Shaft	1
76		Set Screw, M5x12	1
77		Elevation Worm Gear	1
78		Phillips Head Screw with Lock Washer, M5x12	1
79		Bevel Lock Lever	1
80		Lock Screw, M10-1.5x25 (Double Pitch)	1
81		10mm Lock Washer	1
82		10mm Flat Washer, Plastic	1
83		Phillips Head Screw, M5x12	1
84		Trunnion Side Cover	1
85		Wing Screw with Lock Washer, M5x12	3
86	BL1040	Blade, 10", 40T, 5/8" Arbor, 1.6mm Thickness	1
87	TT1015-087	Blade Flange	1
88	TT1015-088	Blade Nut, 5/8"-12 Double Pitch	1
89		Right Cover	1
90		Phillips Head Screw with Flat Washer, M5x10	2
91		4mm Flat Washer	2
92		Self-Tapping Screw, M4x10	2
93		6mm Flat Washer	3

EXPLODED VIEW & PARTS LIST

No.	Part No.	Description	Qty.
94		Extension Wing Assembly	1
95	TT1015-095	Miter Gauge Assembly	1
96		Fence Mounting Knob, M6	1
97		Lock Nut, M6	1
98		Self-Tapping Screw M5-2.12x12	19
99		Anti-Kickback Pawl Mounting Bracket	1
100		Left Cover Panel	1
101		6mm Flat Washer	1
102		Hex Bolt, M6x40	1
103		Cord Clamp	1
104		Self-Tapping Screw, M4-1.41x12	2
105		Phillips Head Screw with Flat Washer, M5x43	12
106		Frame Bumper 1	4
107		Frame Bumper 2	4
108		Hex Flange Nut, M5	12
109		Frame	1
110		Cord Bushing	1
111		Rear Cover Panel	1
112		Blade Guard Bracket	1

No.	Part No.	Description	Qty.
113		Phillips Head Screw, M5x40	2
114	TT1015-114	Push Stick	1
115	TT1015-115	Blade Wrench	1
116		Right Cover Panel	1
117		Switch Stop Plate	1
118		Switch Lock Plate	1
119		Power Switch	1
120		Switch Stop Plate Pin	1
121		Switch Mounting Plate	1
122		Cap Lock Screw, M5x8	2
123		Front Cover Plate	1
124		Support Plate	1
125		Bevel Stop Cam	2
126		Phillips Head Screw, M4x6	3
127.2		Bevel Scale Label	1
128		Switch Box	1
129		Self-Tapping Screw, M4-1.41x16	8
130		Strain Relief	2
131		Power Cord (2-Prong, SJ, 14AWG)	1

NOTE: Not all parts may be available for purchase. Parts and accessories that wear down over the course of normal use are not covered under the warranty.

WARRANTY STATEMENT

WEN Products is committed to building tools that are dependable for years. Our warranties are consistent with this commitment and our dedication to quality.

LIMITED WARRANTY OF WEN PRODUCTS FOR HOME USE

GREAT LAKES TECHNOLOGIES, LLC (“Seller”) warrants to the original purchaser only, that all WEN consumer power tools will be free from defects in material or workmanship during personal use for a period of two (2) years from date of purchase or 500 hours of use; whichever comes first. Ninety days for all WEN products if the tool is used for professional or commercial use. Purchaser has 30 days from the date of purchase to report missing or damaged parts.

SELLER’S SOLE OBLIGATION AND YOUR EXCLUSIVE REMEDY under this Limited Warranty and, to the extent permitted by law, any warranty or condition implied by law, shall be the replacement of parts, without charge, which are defective in material or workmanship and which have not been subjected to misuse, alteration, careless handling, misrepair, abuse, neglect, normal wear and tear, improper maintenance, or other conditions adversely affecting the Product or the component of the Product, whether by accident or intentionally, by persons other than Seller. To make a claim under this Limited Warranty, you must make sure to keep a copy of your proof of purchase that clearly defines the Date of Purchase (month and year) and the Place of Purchase. Place of Purchase must be a direct vendor of Great Lakes Technologies, LLC. Purchasing through third party vendors, including but not limited to garage sales, pawn shops, resale shops, or any other secondhand merchant, voids the warranty included with this product. Contact tech-support@wenproducts.com or 1-800-232-1195 with the following information to make arrangements: your shipping address, phone number, serial number, required part numbers, and proof of purchase. Damaged or defective parts and products may need to be sent to WEN before the replacements can be shipped out.

Upon the confirmation of a WEN representative, your product may qualify for repairs and service work. When returning a product for warranty service, the shipping charges must be prepaid by the purchaser. The product must be shipped in its original container (or an equivalent), properly packed to withstand the hazards of shipment. The product must be fully insured with a copy of the proof of purchase enclosed. There must also be a description of the problem in order to help our repairs department diagnose and fix the issue. Repairs will be made and the product will be returned and shipped back to the purchaser at no charge for addresses within the contiguous United States.

THIS LIMITED WARRANTY DOES NOT APPLY TO ITEMS THAT WEAR OUT FROM REGULAR USAGE OVER TIME, INCLUDING BELTS, BRUSHES, BLADES, BATTERIES, ETC. ANY IMPLIED WARRANTIES SHALL BE LIMITED IN DURATION TO TWO (2) YEARS FROM DATE OF PURCHASE. SOME STATES IN THE U.S. AND SOME CANADIAN PROVINCES DO NOT ALLOW LIMITATIONS ON HOW LONG AN IMPLIED WARRANTY LASTS, SO THE ABOVE LIMITATION MAY NOT APPLY TO YOU.

IN NO EVENT SHALL SELLER BE LIABLE FOR ANY INCIDENTAL OR CONSEQUENTIAL DAMAGES (INCLUDING BUT NOT LIMITED TO LIABILITY FOR LOSS OF PROFITS) ARISING FROM THE SALE OR USE OF THIS PRODUCT. SOME STATES IN THE U.S. AND SOME CANADIAN PROVINCES DO NOT ALLOW THE EXCLUSION OR LIMITATION OF INCIDENTAL OR CONSEQUENTIAL DAMAGES, SO THE ABOVE LIMITATION OR EXCLUSION MAY NOT APPLY TO YOU.

THIS LIMITED WARRANTY GIVES YOU SPECIFIC LEGAL RIGHTS, AND YOU MAY ALSO HAVE OTHER RIGHTS WHICH VARY FROM STATE TO STATE IN THE U.S., PROVINCE TO PROVINCE IN CANADA AND FROM COUNTRY TO COUNTRY.

THIS LIMITED WARRANTY APPLIES ONLY TO ITEMS SOLD WITHIN THE UNITED STATES OF AMERICA, CANADA AND THE COMMONWEALTH OF PUERTO RICO. FOR WARRANTY COVERAGE WITHIN OTHER COUNTRIES, CONTACT THE WEN CUSTOMER SUPPORT LINE. FOR WARRANTY PARTS OR PRODUCTS REPAIRED UNDER WARRANTY SHIPPING TO ADDRESSES OUTSIDE OF THE CONTIGUOUS UNITED STATES, ADDITIONAL SHIPPING CHARGES MAY APPLY.

**THANKS FOR
REMEMBERING**  [®]