



HOME

WATER SOFTENER

INSTALLATION MANUAL



Welcome to the NuvoH2O Family of Whole-Home Water Softener Systems



Congratulations on your purchase of the Home Water Softener. Instead of using salt or potassium, NuvoH2O uses a proprietary, natural citrus formulation to soften and condition your home's water. Initially developed for the food service industry in the early 1980s, this technology has been solving complex water problems for some of the nation's largest businesses.

You are about to enjoy healthy, softened water that both prevents and removes hard water buildup that clogs and corrodes water heaters, appliances, and plumbing fixtures—each critical to your home and expensive to replace.

What to Expect With Your Home Water Softener System

The Home Water Softener binds naturally occurring minerals to prevent hard water buildup instead of just removing the minerals like old-fashioned, salt-based water softeners. Natural mineralized water is healthy, which will not be affected during the NuvoH2O softening process and will not affect the taste of your water.

NuvoH2O-softened water requires less soap in your dishwasher and when doing laundry. In fact, you can decrease up to half the amount of detergent for both.

Avoid using pre-soaks or rinse-aids since too much of either can actually cause a fine white film or spots to form on dishes. This spotting can also be aggravated by some of the non-phosphate detergents found in many states.

The NuvoH2O softener creates natural, pH-balanced water that is healthier for hair and skin. The softened, mineralized water will not produce that slick, can't-rinse-off-the-soap feeling you may have experienced in the shower when using an old-fashioned salt softener.

Simple & Effective

The Home Water Softener is the most simple and effective softener available. It requires no drains, no electricity, no calibration, and little maintenance. Because the softening formula is citric-acid based, an FDA-approved compound, it is safe for all household uses, including drinking, bathing, and watering plants. Your new NuvoH2O system mounts directly to your home's main internal water line and doesn't require a soft-water loop.

We strongly suggest hiring a certified installer or professional plumber. However, if you are experienced with home plumbing, we've included these instructions to install your NuvoH2O softener. Please note that by choosing to install your system yourself, you assume the liability for its installation.

Package Contents

This package includes: system housing (head and sump), mounting bracket, softening cartridge, wrench, tapcon screw pack, system head screw pack, O-ring, lubricant, installation guide, and

warranty/registration card. Because plumbing standards vary, other bushings and connectors are not included.

System Maintenance

Once installed, your NuvoH2O Home Water Softener requires minimal maintenance. The only maintenance you should expect to perform is when it comes time to replace your cartridge about every six months. You should also replace the O-ring with every other cartridge replacement. See page 5.

Again, thank you for choosing NuvoH2O. We look forward to providing you with convenient, eco-friendly, salt-free and potassium-free soft water for many years to come!

Before Installation

- Ensure that any electrical plugs in the area are covered or disconnected.
- Ensure that the existing plumbing is up to code.
- Identify what material the plumbing/ pipe is composed of.
- Turn off water main.
- Acquire and install a pressure regulator with your system.

Warnings & Cautions

- Maximum working temperature is 113° F (45° C). Minimum working temperature is 39° F (4°C). Maximum working pressure is 125 PSI (8.6 bar) Minimum working pressure is 7.25 PSI (0.5 bar).
- Do not install near electrical appliances.
- Do not use with water that is micro-biologically unsafe or of unknown quality without adequately treating or disinfecting water before the system.
- The NuvoH2O softener is intended for the treatment of hard water with alkaline pH; do not install if inlet water has a pH of 7.2 or less.
- Lubricate (included) O-ring.
- Install in a room that protects it from freezing and excessive heat.
- Ensure that the plumbing has been installed according to the plumbing code before installation.
- Ensure that the water main has been shut off prior to installation.
- Replace cartridge at least every six months. You may need to replace cartridges more frequently based on water usage.
- Failure to replace the cartridge in recommended intervals may result in poor softener performance and/or cracks in the housing, causing leakage and possible flooding.

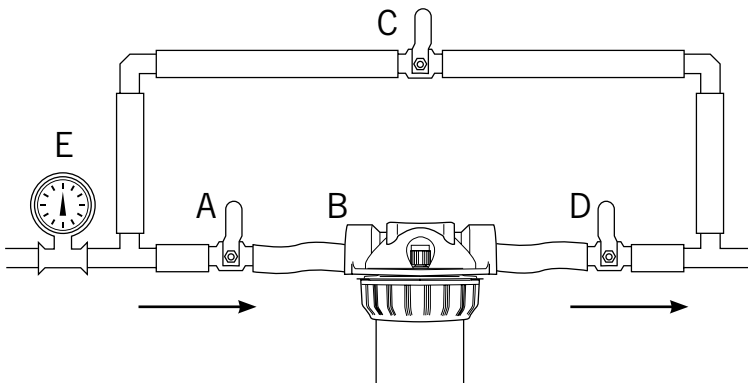

Installation Instructions

1. Verify the water main has been shut off.
2. Using a stud finder, attach mounting bracket to the studs in the wall.
3. Remove the system from package. Remove all foam packing and any plastic wrap. Be sure to check inside the system for any loose foam, plastic, or package contents.
4. Install the system by attaching the head to the mounting bracket. Ensure that the system is installed vertically with the blue head at the top of the system. Do not invert the system.
5. Install a pressure regulator (E) ahead of the NuvoH2O system. Set for 45-65 PSI. A pressure spike, though unlikely, can still damage the system if it is not protected and potentially result in leaks.
6. Install a bypass. See the diagram on page 3.
7. Use flexible hoses to connect the inlet pipe to the inlet port on the system. Use flexible hoses to connect the outlet port of the system head to the outlet pipe. Failure to use flexible hoses may result in water leakage.
8. Use Teflon tape to seal the connections.
9. Lubricate (included) the O-ring at the top of the housing sump.
10. Remove the protective plastic wrap from the cartridge(s) before inserting into housing.
11. Insert and seat the cartridge into the sump. The small, round holes on the side of the cartridge must be at the top. See the cartridge replacement instructions for more details.
12. Carefully attach sump with cartridge to the head with collar. Tighten the collar to head by rotating clockwise (right). Secure using the wrench provided.
13. Open the pressure release valve on the top of the head using a screwdriver (do not remove the pressure release valve, only loosen it).
14. Open the first bypass valve (A), allowing the sump to fill with water. When water leaks from the pressure release valve at the top of the head, tighten to close (B).
15. Close the first bypass valve (A), allow cartridge to sit in the housing with minimal water flow for one hour. Open main valve (C), thus allowing water to flow throughout the household while cartridge sits.
16. After one hour, close the top bypass valve (C) and open the first and last bypass valves (A&D), allowing water to flow through the system.



NuvoH2O Cartridge Replacement

1. Before replacing your cartridge, we recommend having a towel on hand and placing a bucket underneath your softener system to catch any water that may spill. The bucket should also be used to carry your spent cartridge as the concentrated solution can damage flooring if it drips.
2. Discontinue water flow to the system by closing valves A and D (see diagram on page 3). Open valve C, allowing water to flow to the home. Loosen pressure release valve in the head of the system with a screwdriver. Use towel to absorb water that leaks from valve.
3. Using the black plastic wrench provided, turn the blue collar clockwise (left) to loosen the sump from the head of the system.
CAUTION: The sump will be heavy and full of water!
4. Remove the spent cartridge. Turn it upside down into a sink or tub and let it drain completely. The outside of the cartridge can be rinsed with warm water. The water that empties from the cartridge will be very concentrated. **DO NOT** allow it to come in contact with copper, stone (natural or unsealed), carpet, cement, or other flooring.
5. Clean the inside of the sump with dish soap, 1/2 teaspoon bleach, and water. Rinse thoroughly.
6. Remove the plastic shrink wrap from your new cartridge and insert the cartridge into the sump. The small, round holes on the side of the cartridge must be at the top.
7. Be sure to align the cartridge properly in the sump. Failure to do so may cause the cartridge to crack when tightening the collar back to the head.
8. Inspect O-ring, on the top of the sump, for wear. Ensure it is seated properly. Lubricate O-ring with a water-based lubricant or replace as needed.
9. Place the sump directly under the head so that the collar may be re-tightened. Tighten the collar by turning counterclockwise (right). Secure with wrench.
10. Open the first bypass valve (A), allowing the sump to fill with water. When water leaks from the pressure release valve at the top of the head, tighten to close (B).
11. Close the first bypass valve (A), allow cartridge to sit in the housing with minimal water flow for one hour. Open main valve (C), thus allowing water to flow throughout the household while the cartridge sits idle.
12. After one hour, close the top bypass valve (C) and open the first and last bypass valves (A&D), allowing the water to flow through the system.



Money-Back Guarantee

We're so confident in the performance of the NuvoH2O Salt-Free Water Softeners, that if you are not completely satisfied within the first 90 days from the date of purchase, you may return it for a full refund of your purchase price, less shipping and handling.

Everyone's water quality is different. If you're not getting results you expect, we may be able to help you adjust the treatment level from your softener to improve your water quality. Please contact us if we can be of any assistance.

5-Year Limited Warranty

In the unlikely event that you experience a manufacturing defect with your system, NuvoH2O may either repair, modify, or exchange your softener. To qualify for warranty, you must purchase the system directly from NuvoH2O or an authorized

NuvoH2O reseller, register your system with NuvoH2O, and use only genuine NuvoH2O replacement cartridges and parts. For full warranty details, visit NuvoH2O.com.

Product Registration

To register your NuvoH2O system, visit: NuvoH2O.com/register

If you do not have access to a computer please call one of our helpful customer service agents at: 877-688-6426.

Or, simply mail back the registration card included with your system.





877-688-6426 | NuvoH2O.com

v.11/2020

