

ASSEMBLY INSTRUCTIONS

ITEM NO. WF316556&WF316557&WF316558

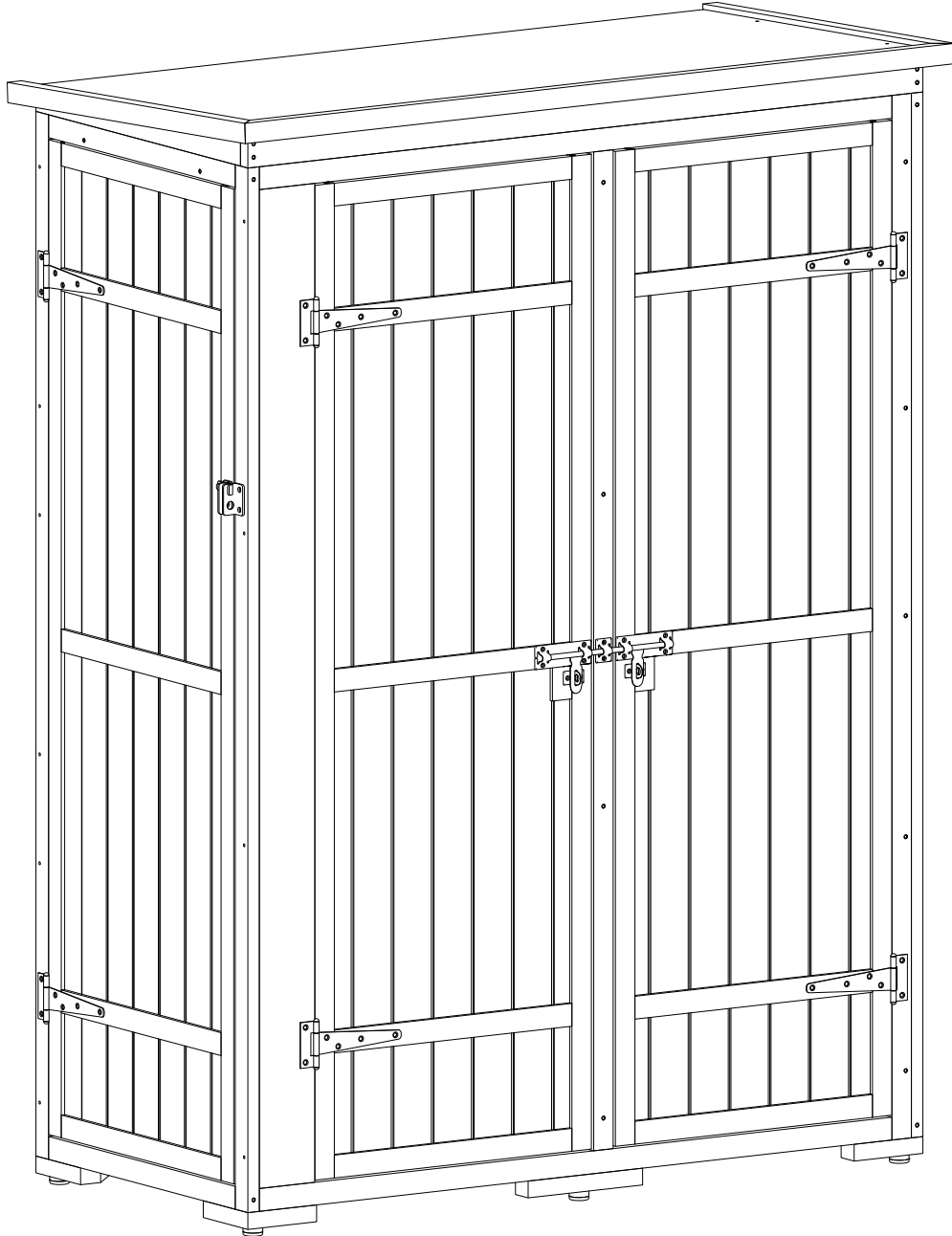







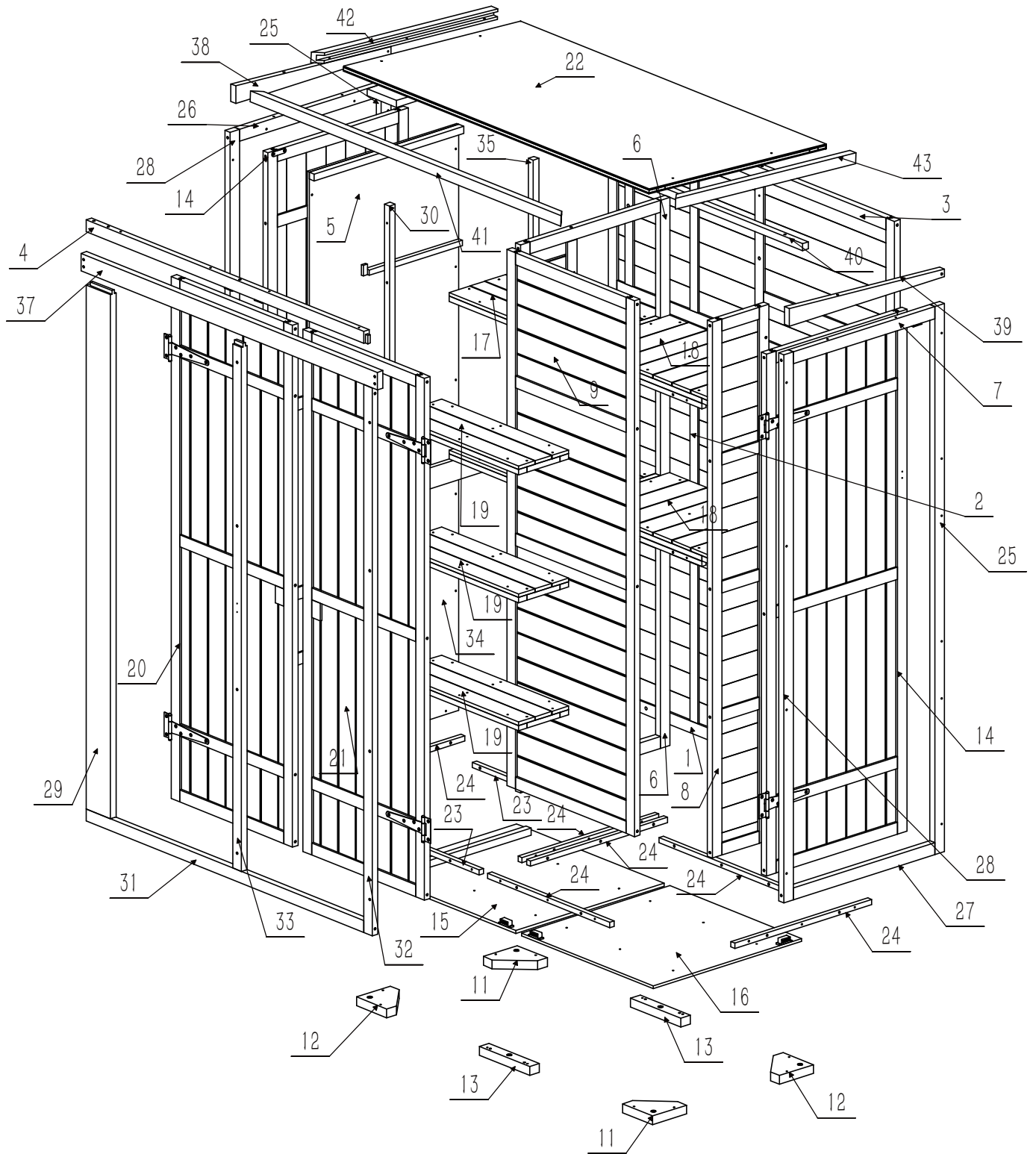



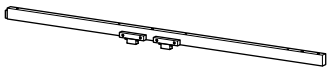
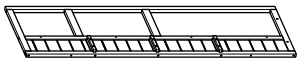
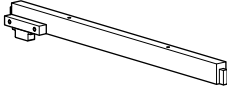

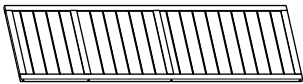
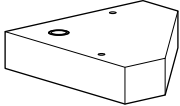

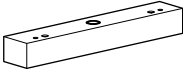
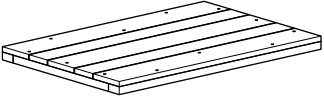
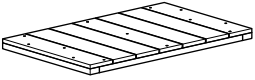
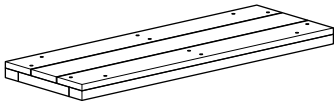
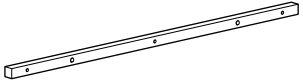
IMPORTANT NOTE :

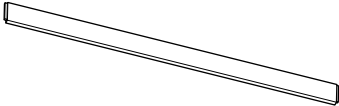
- ① PLACE ALL PARTS ON A CLEAN AND SMOOTH SURFACE SUCH AS A RUG OR CARPET TO AVOID THE PARTS FROM BEING SCRATCHED.
- ② BEFORE YOU BEGIN, KINDLY FOLLOW THE ASSEMBLY INSTRUCTIONS STEP BY STEP.
- ③ DO NOT TIGHTEN ALL SCREWS AND BOLTS UNTIL THIS ITEM IS FULLY SET-UP.

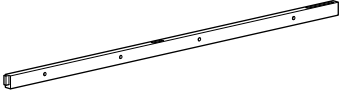

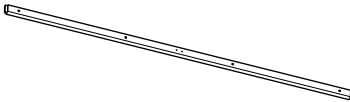

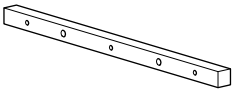
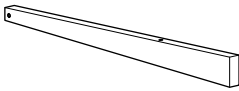
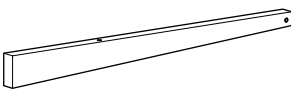

Detail View

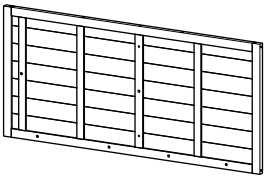
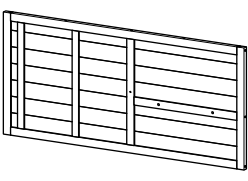
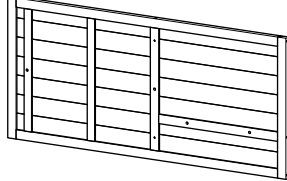
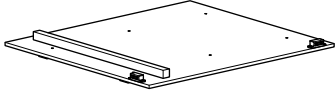
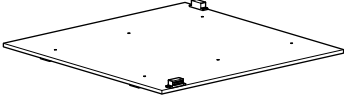

Hardware List (WF316556)

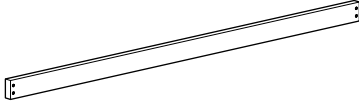
4	6	7	8
			
Upper slat of front panel-1PC	Middle panel-1PC	Upper slat of left panel-1PC	Right middle panel-1PC
9	11	12	13
			
Back partition-1PC	Wood block①-2PCS	Wood block②-2PCS	Wood block③-2PCS
17	18	19	23
			
Shelf①-2PCS	Shelf②-2PCS	Shelf③-3PCS	Support of front&back panel-2PCS
25	28	29	30
			
Left vertical slat of side panel-2PCS	Right vertical slat of side panel-2PCS	Wood board of front panel-1PC	Left vertical slat of front panel-1PC
31	32	33	35
			
Lower horizontal slat of front panel-1PC	Right vertical slat of front panel-1PC	Middle vertical slat of front panel-1PC	Connection of back panel-1PC
36	38	39	40
			
Support of Middle partition-2PCS	Left wood board of roof-1PC	Right wood board of roof-1PC	Back wood board of roof-1PC
			
Hardware Kit-1PC			

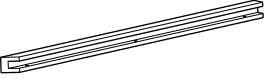





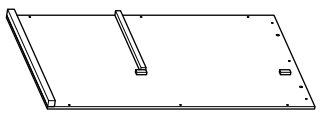
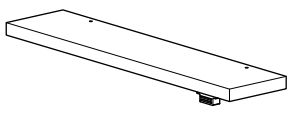
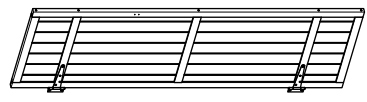
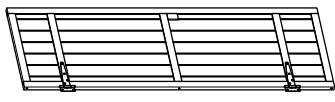
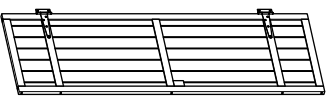
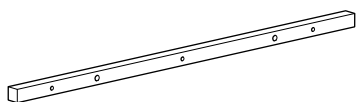
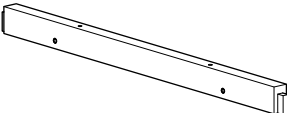
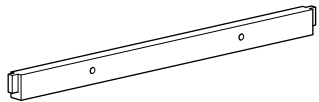
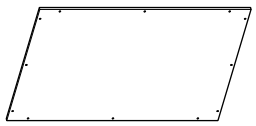
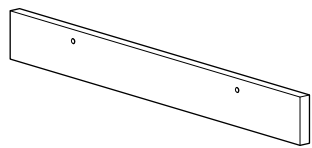





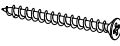

Hardware List (WF316557)

1	2	3	15
			
Lower of back panel-1PC	Middel of back panel-1PC	Upper of back panel-1PC	Bottom panel ①-1PC
16	22	37	41
			
Bottom panel ②-1PC	Roof-1PC	Front wood board of roof-1PC	Slot of roof-1PC
42	43		
			
Left slot of roof-1PC	Right slot of roof-1PC		

Hardware List (WF316558)

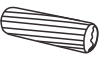
5	10	14	20
			
Left middle panel-1PC	Cover board-1PC	Door of side panel-2PCS	Left door of front panel-1PC
21	24	26	27
			
Right doof of front panel-1PC	Side support of front&back panel-10PCS	Upper slat of left side panel-1PC	Lower slat of side panel-2PCS
34	44		
			
Lower left partition OSB board-1PC	Connection of left middle partition-1PC		

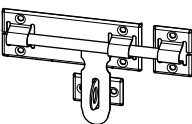
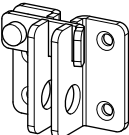
Hardware List

<p>A</p>  <p>3.5*60</p> <p>Ph zinc screws-16+1pcs</p>	<p>B</p>  <p>3.5*50</p> <p>Ph zinc screws-8+1pcs</p>	<p>C</p>  <p>3.5*45</p> <p>Ph zinc screws-12+1pcs</p>	<p>D</p>  <p>3.5*40</p> <p>Ph zinc screws-56+1pcs</p>
<p>E</p>  <p>3.0*35</p> <p>Ph zinc screws-4+1pcs</p>	<p>F</p>  <p>3.0*30</p> <p>Ph zinc screws-51+1pcs</p>	<p>G</p>  <p>3.0*25</p> <p>Ph zinc screws-25+1pcs</p>	<p>H</p>  <p>3.0*20</p> <p>Ph zinc screws-6+1pcs</p>
<p>I</p>  <p>3.5*16</p> <p>Ph zinc screws-16+1pcs</p>	<p>J</p>  <p>3.0*16</p> <p>Ph zinc screws-8+1pcs</p>	<p>K</p>  <p>3.0*14</p> <p>Ph zinc screws-22+1pcs</p>	<p>L</p>  <p>Wood dowel-50+1pcs</p>
<p>M</p>  <p>Ajustable rubber feet-6pcs</p>	<p>N</p>  <p>Metal latch with lock-2pcs</p>	<p>O</p>  <p>Metal latch-2pcs</p>	<p>P</p>  <p>Ground nail-4pcs</p>
<p>Q</p>  <p>Angle steel-4pcs</p>			

ASSEMBLY TOOLS REQUIRED(NOT INCLUDED)

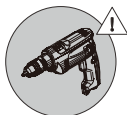

PLEASE BE CAREFUL DO NOT DAMAGE THE HOLE POSITION WHEN YOU USE POWERTOOLS !

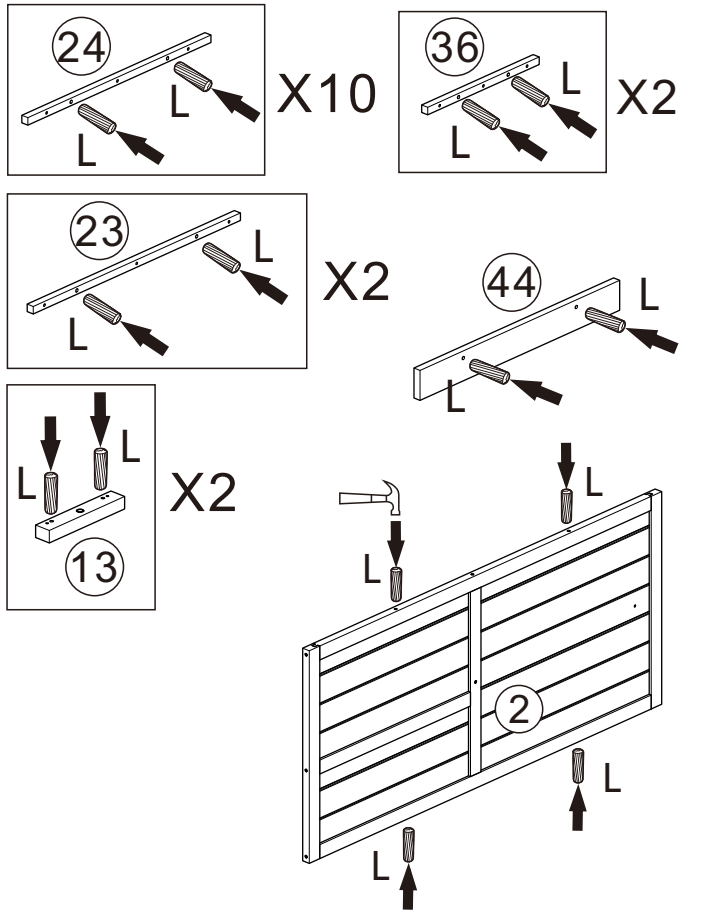

Step 1

Lx38 (2)x1 (13)x2 (23)x2
(24)x10 (36)x2 (44)x1

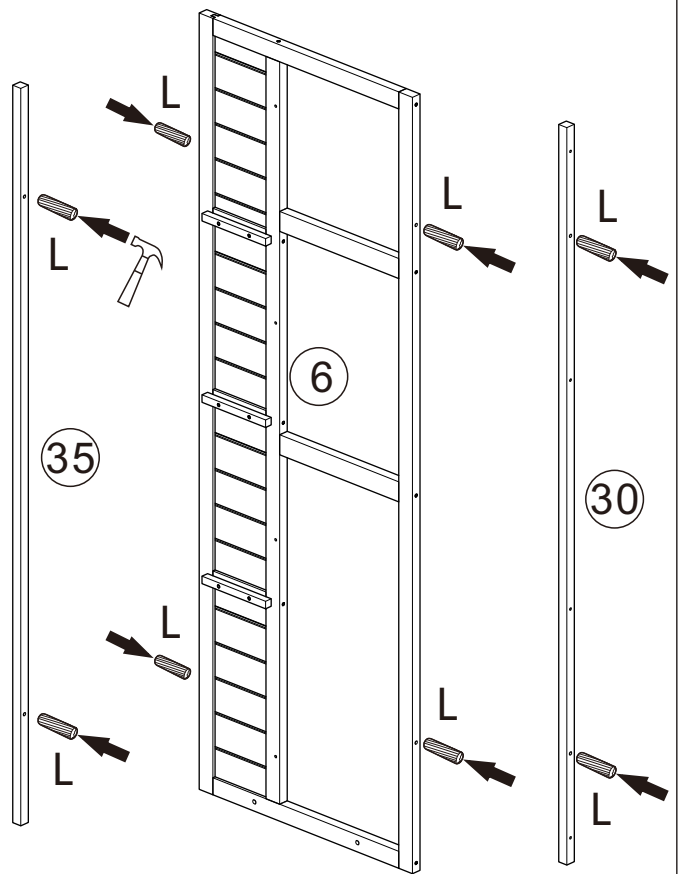

Step 2

Lx8 (6)x1 (30)x1 (35)x1

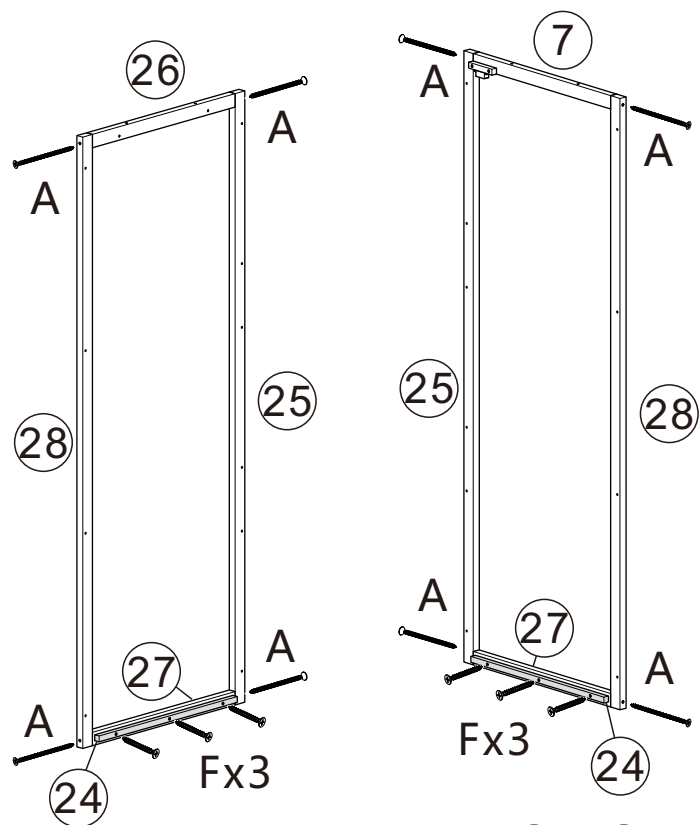

Step 3

Ax8 Fx6 (7)x1 (24)x2
(25)x2 (26)x1 (27)x2 (28)x2

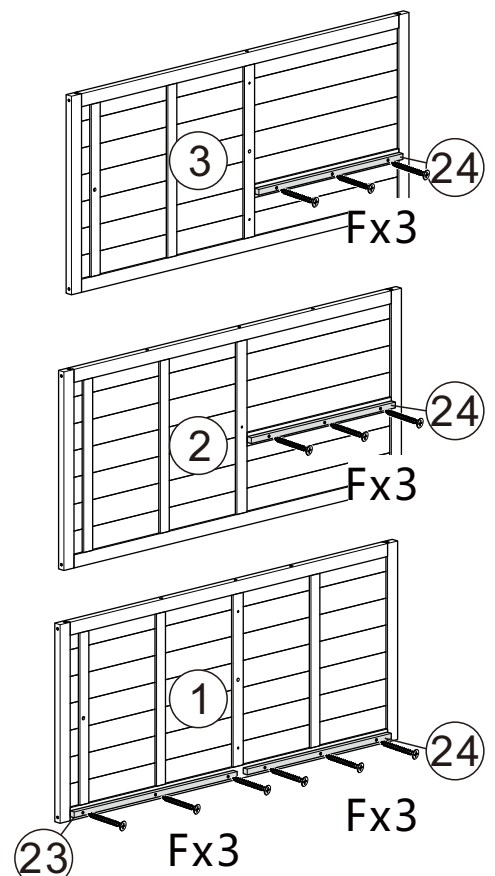

Step 4

Fx12 (1)x1 (2)x1
(3)x1 (23)x1 (24)x3

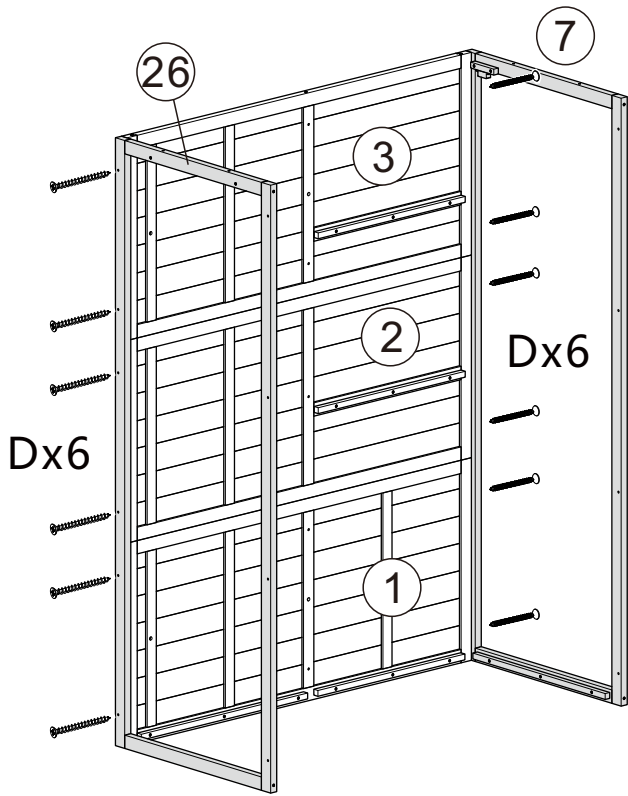

Step 5

Dx12

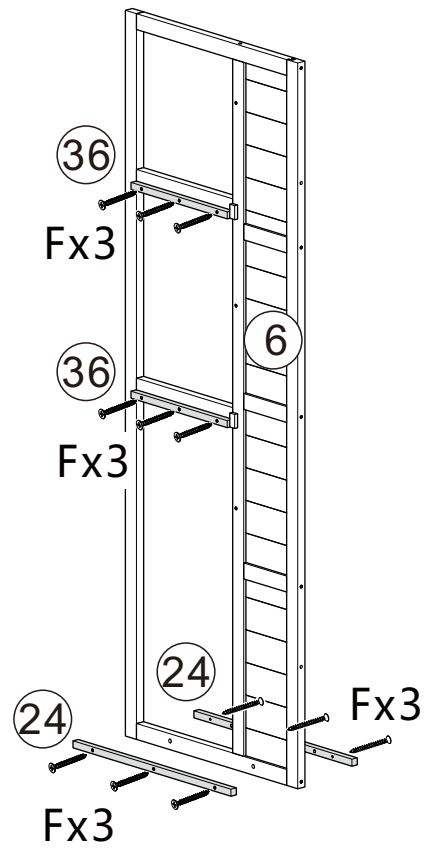

Step 6

Fx12 (6) x1 (24) x2 (36) x2

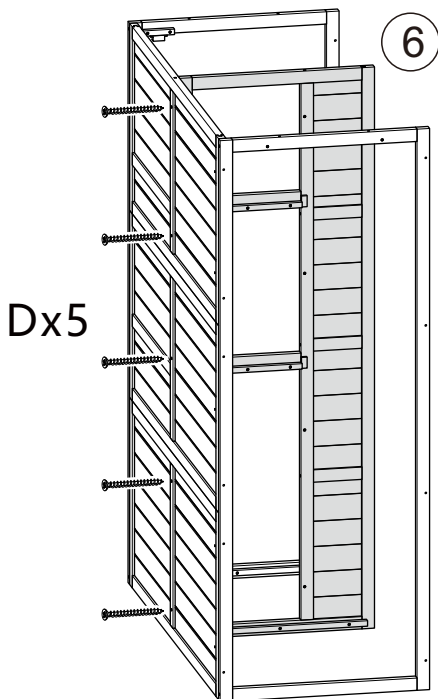

Step 7

Dx5

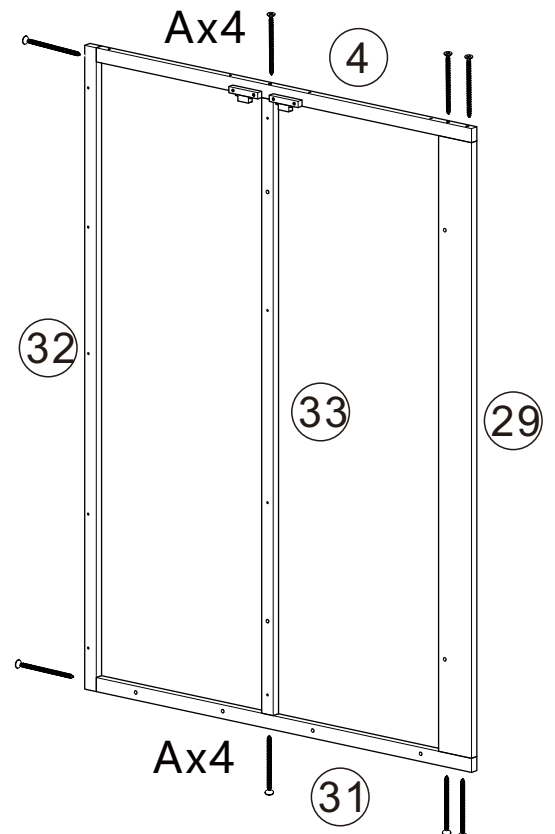

Step 8

Ax8 (4) x1 (29) x1
(31) x1 (32) x1 (33) x1

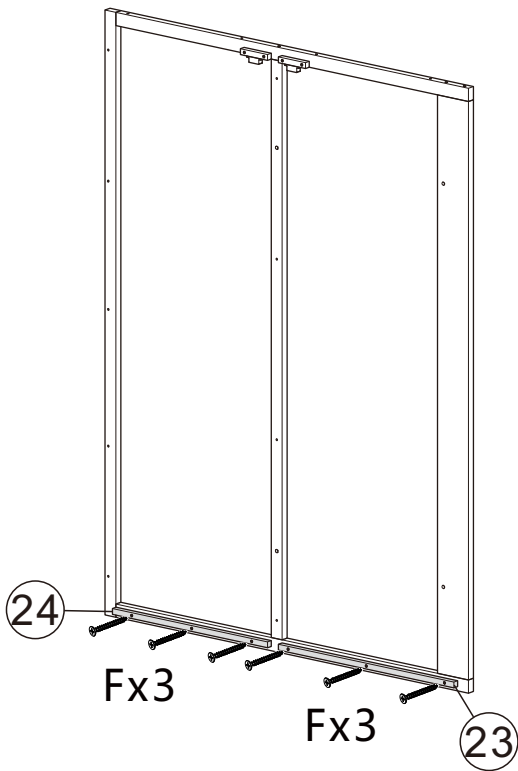

Step 9

Fx6 (23)x1 (24)x1

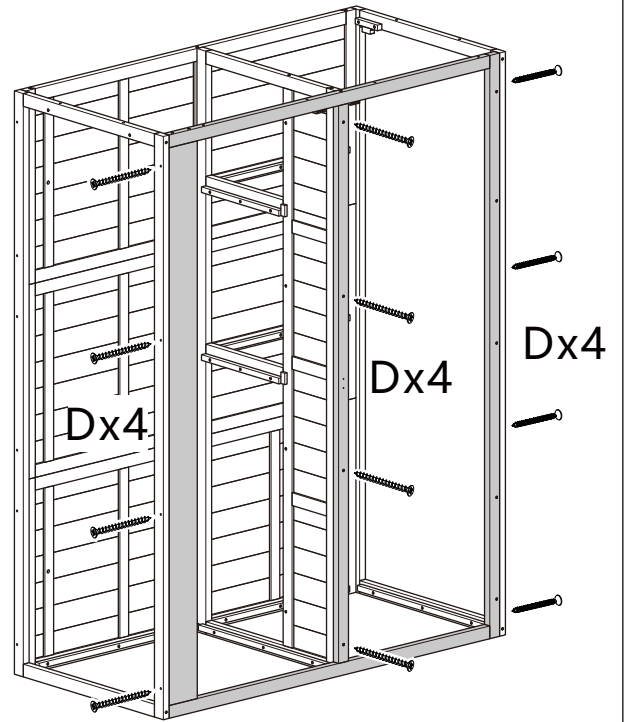

Step 10

Dx12

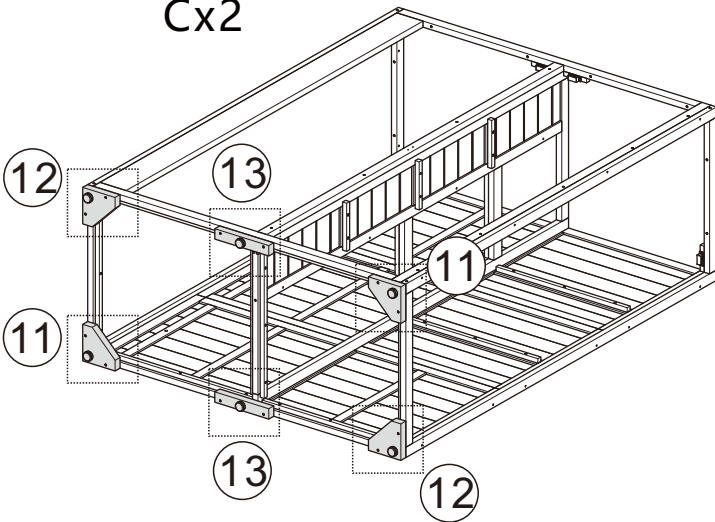
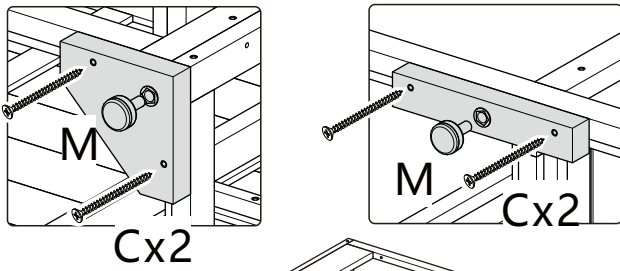

Step 11

Cx12 Mx6 (11)x2 (12)x2 (13)x2

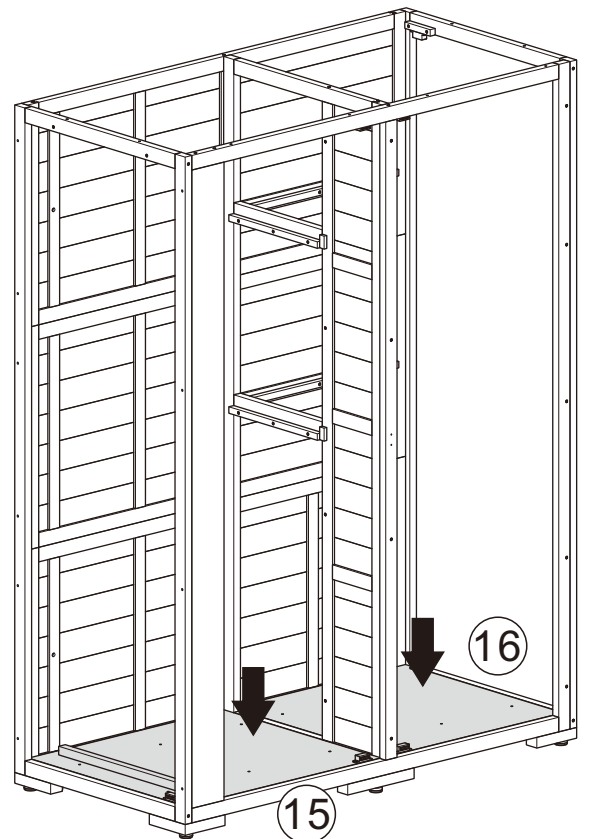

Step 12

(15)x1 (16)x1

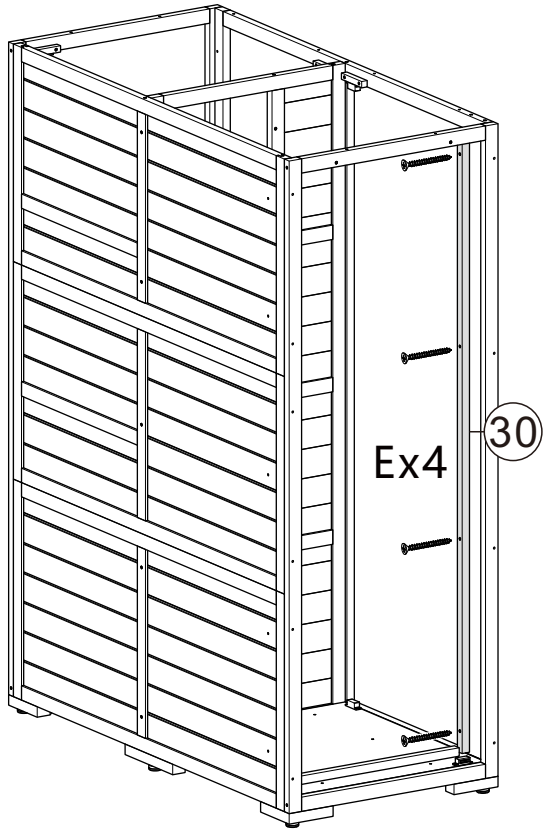

Step 13

Ex4 30 x1

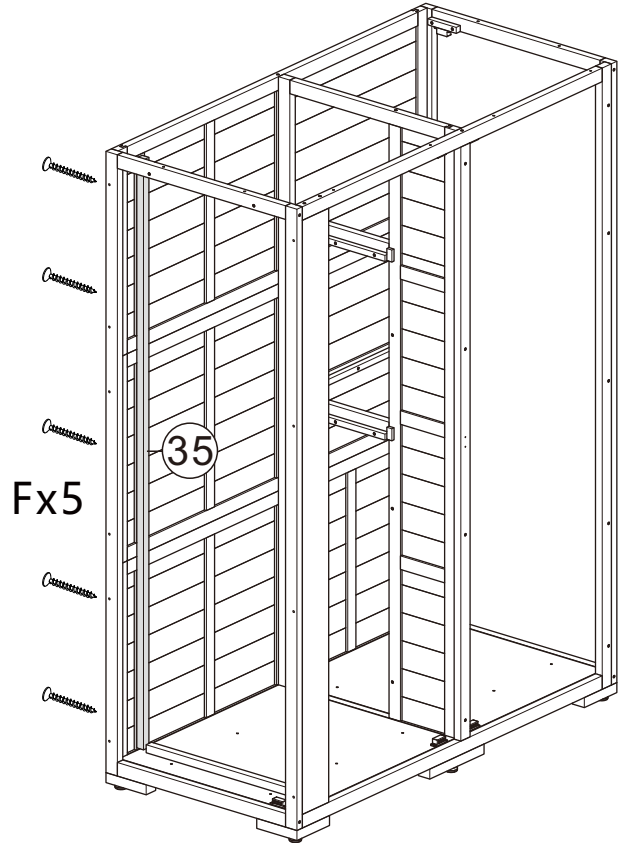

Step 14

Fx5 35 x1

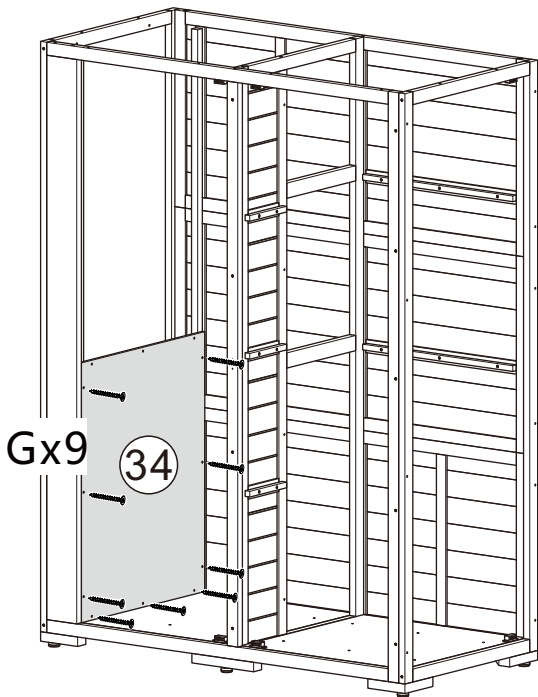

Step 15

Gx9 34 x1

Similar hooks with bolt could be located any position of Part 5. Please reference to bellow picture.

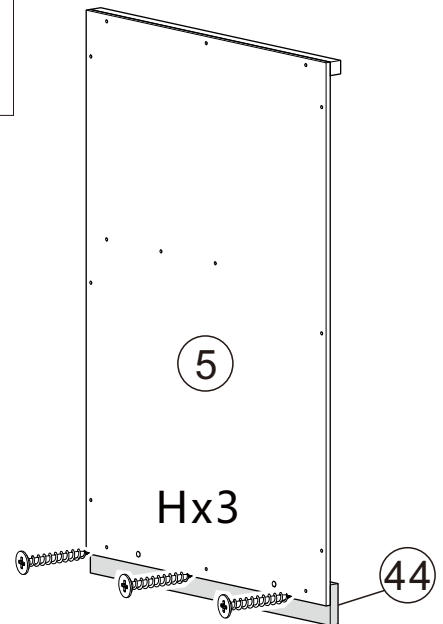
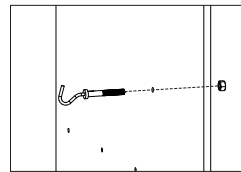

Step 16

Hx3 5 x1 44 x1

Gx6

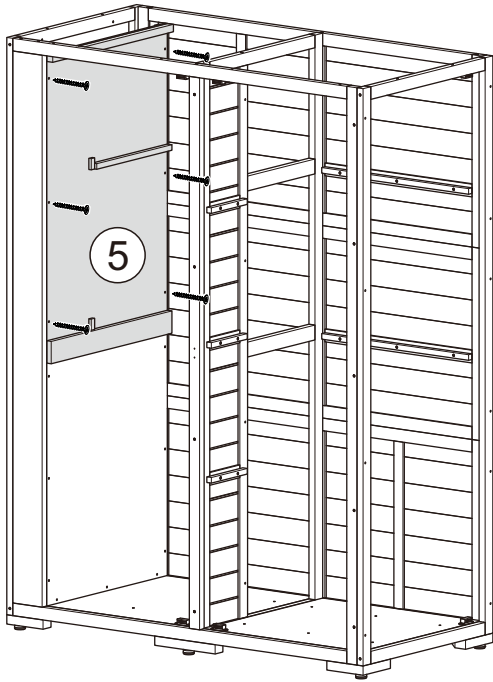

Step 17

Gx6

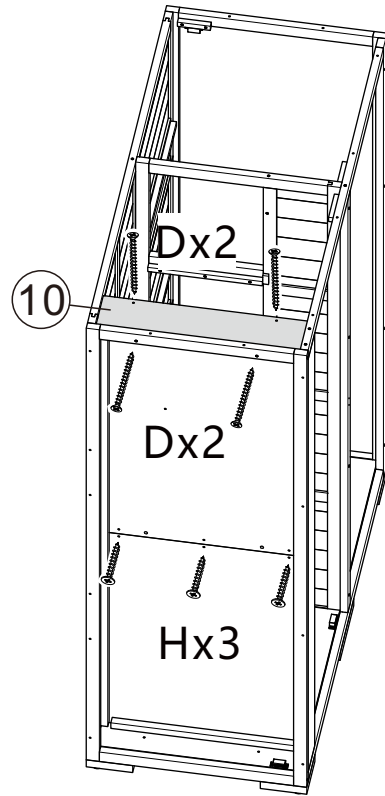

Step 18

Dx4 Hx3 10x1

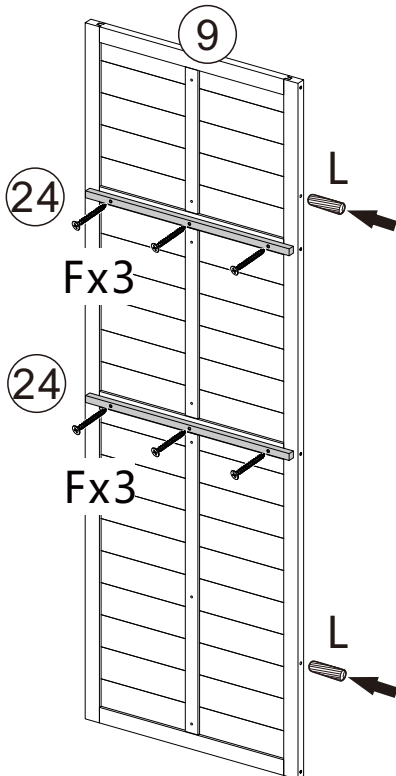

Step 19

Fx6 Lx2 9x1 24x2

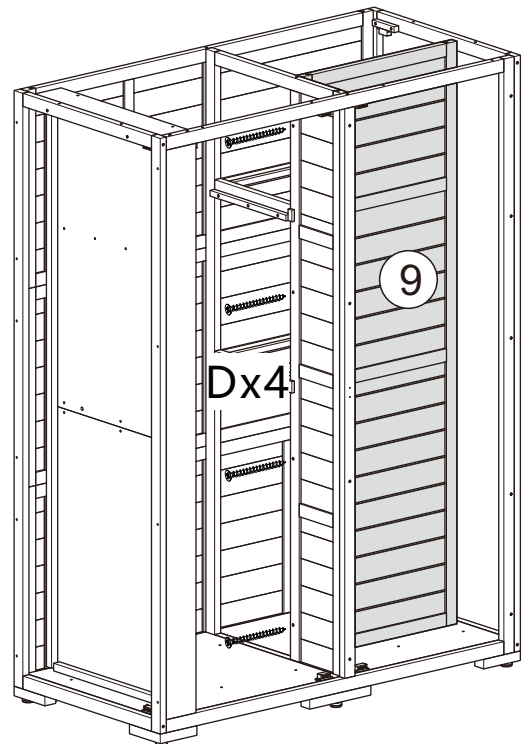

Step 20

Dx4

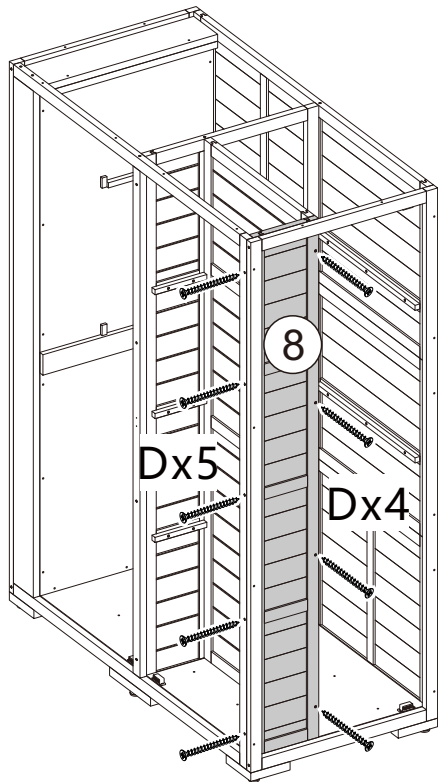

Step 21

Dx9 (8) x1

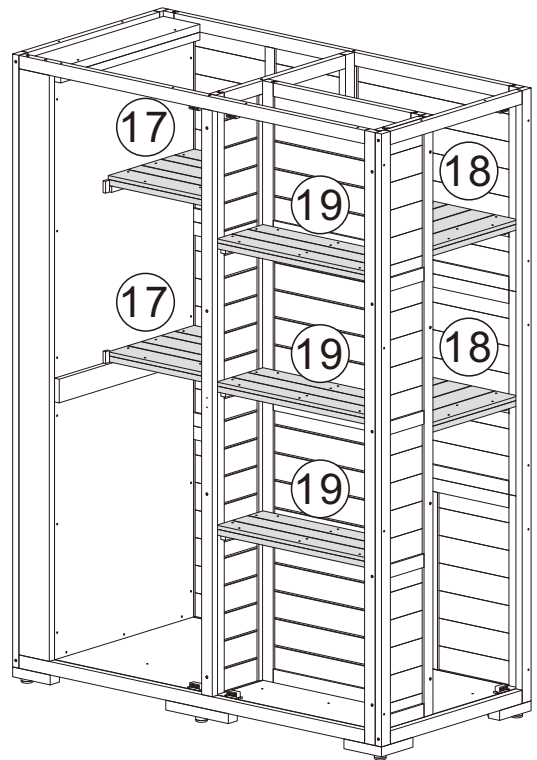

Step 22

(17) x2 (18) x2 (19) x3

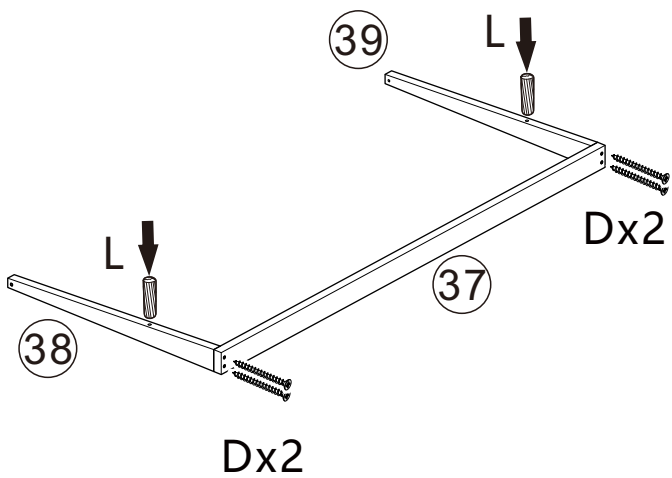

Step 23

Dx4 Lx2 (37) x1
(38) x1 (39) x1

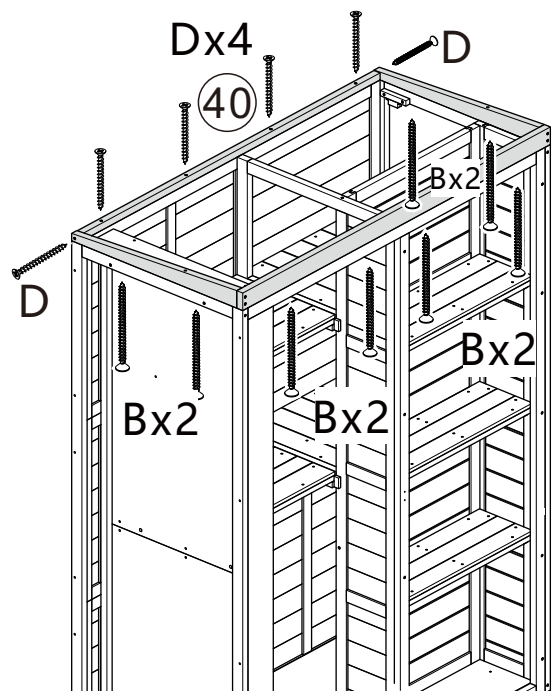

Step 24

Bx8 Dx6 (40) x1

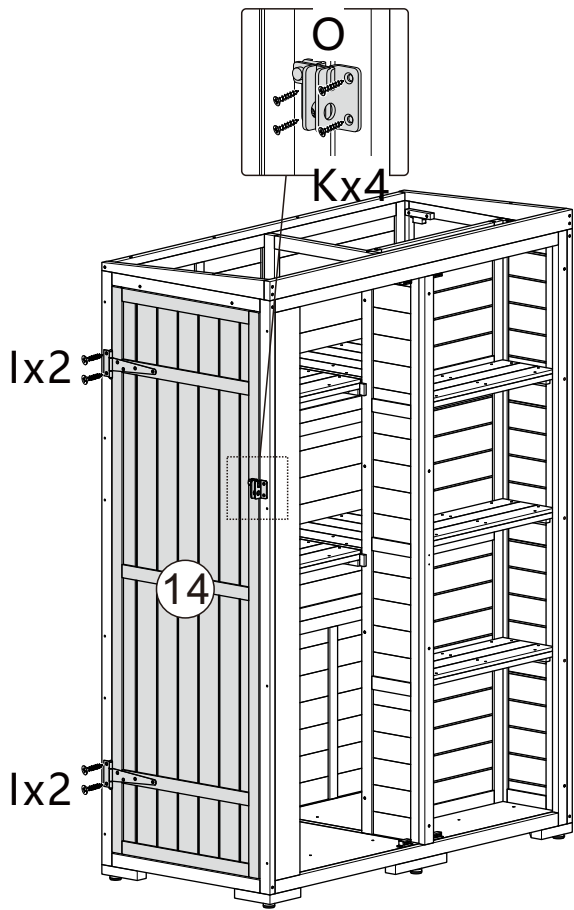

Step 25

$I \times 4$ $K \times 4$ $O \times 1$ ①④ $\times 1$

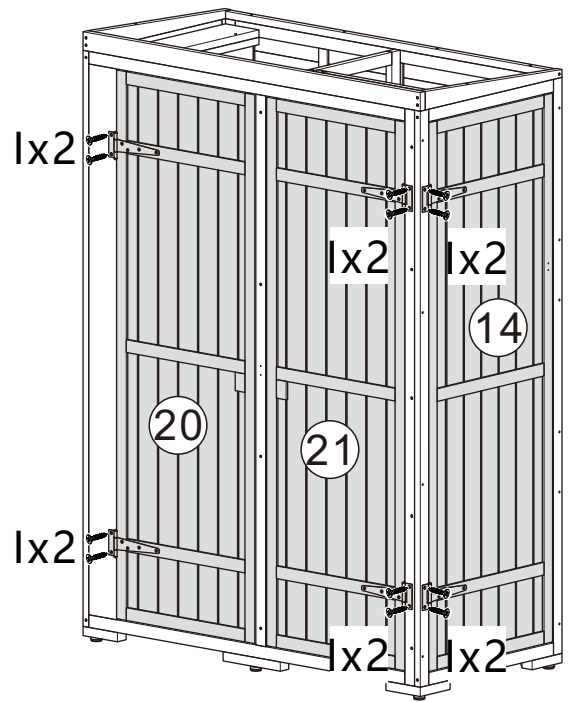

Step 26

$I \times 12$ ①④ $\times 1$ ②① $\times 1$ ②① $\times 1$

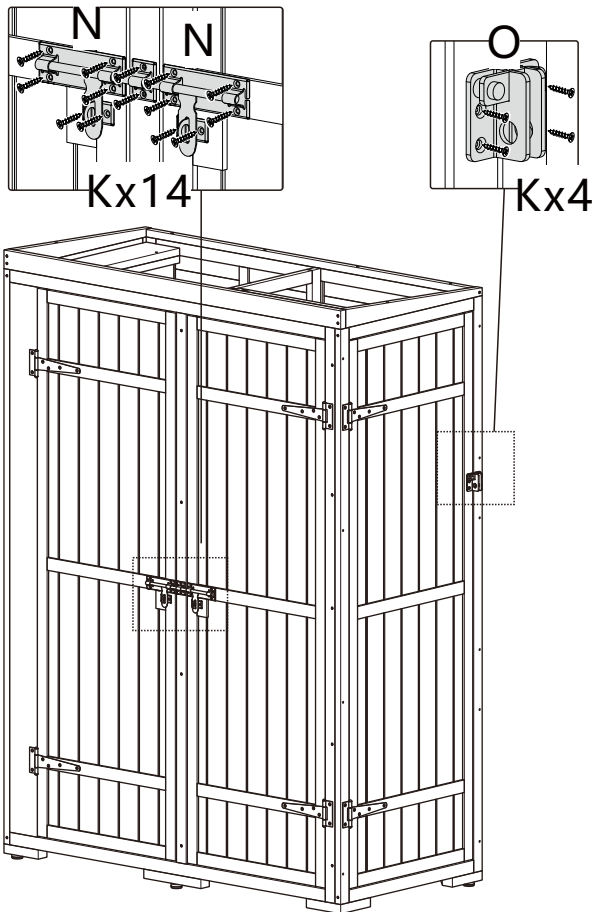

Step 27

$K \times 18$ $N \times 2$ $O \times 1$

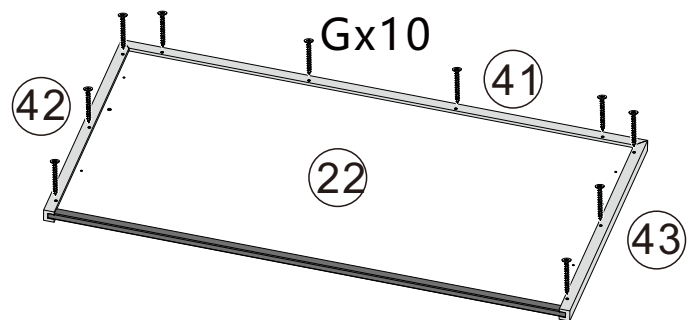

Step 28

$G \times 10$ ②② $\times 1$ ④① $\times 1$
④② $\times 1$ ④③ $\times 1$

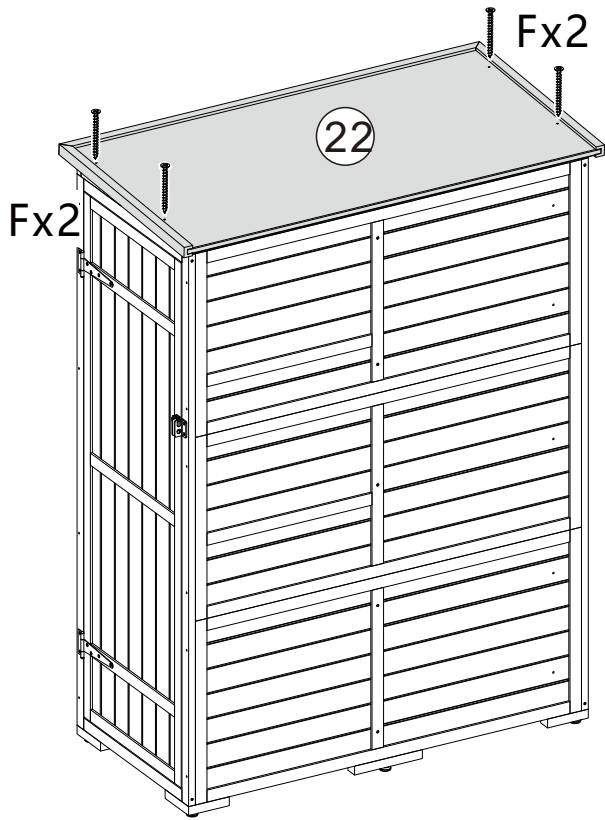

Step 29

Fx4

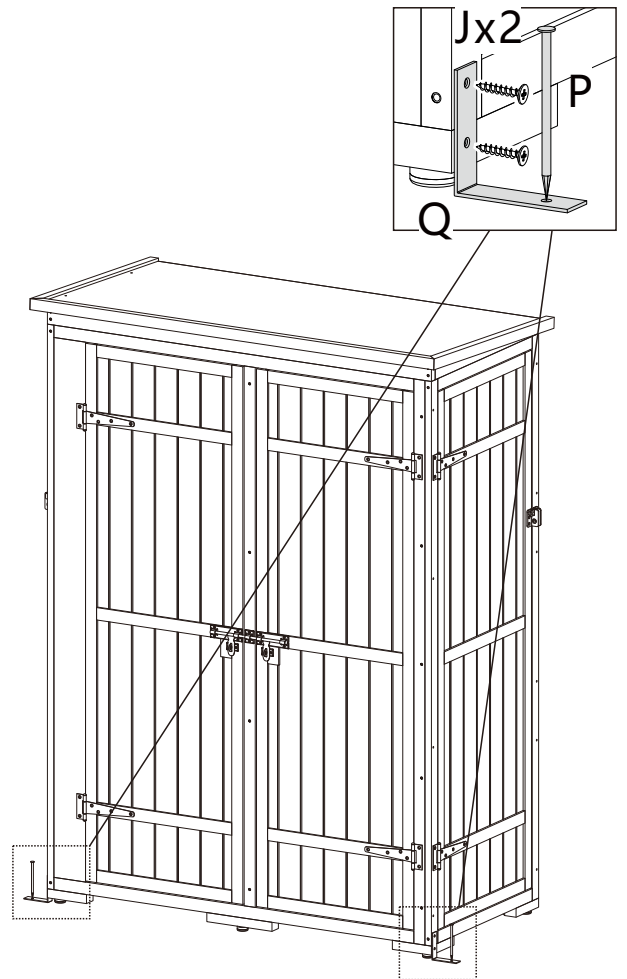

Step 30

Jx4 Px2 Qx2

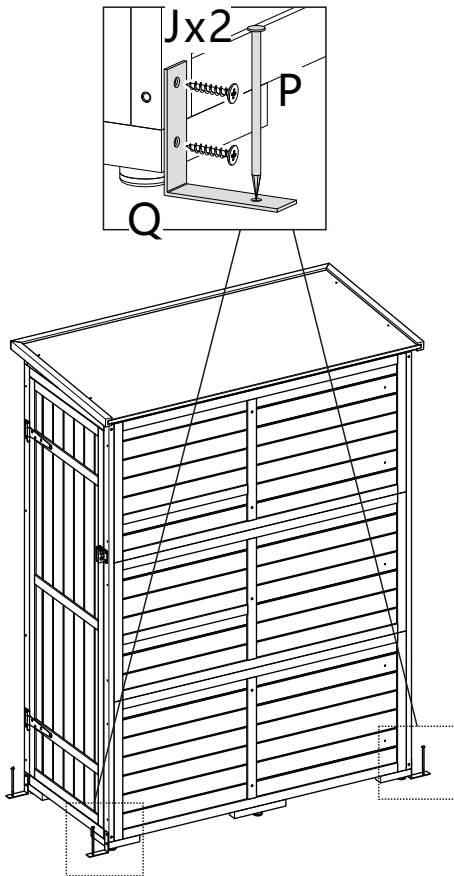

Step 31

Jx4 Px2 Qx2

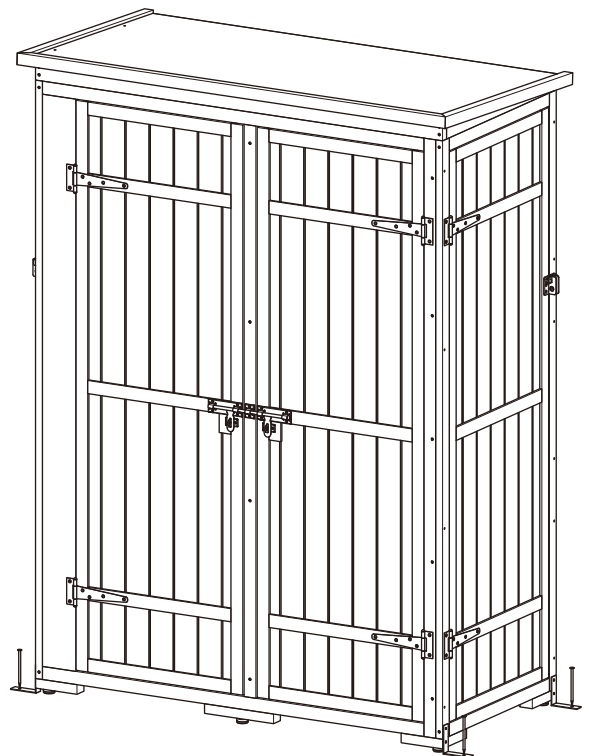

Step 32