



## LED SPOT LIGHT



### PRODUCT DESCRIPTION

LED Spot Lights can mount in almost any angle with a yoke-style arm. They are perfect for illuminating a variety of outdoor applications, including facade, wall washing, flags, statues, monuments, landscapes, and retail complexes. It also provides an added level of security for residential/commercial properties.

## DIMENSIONS

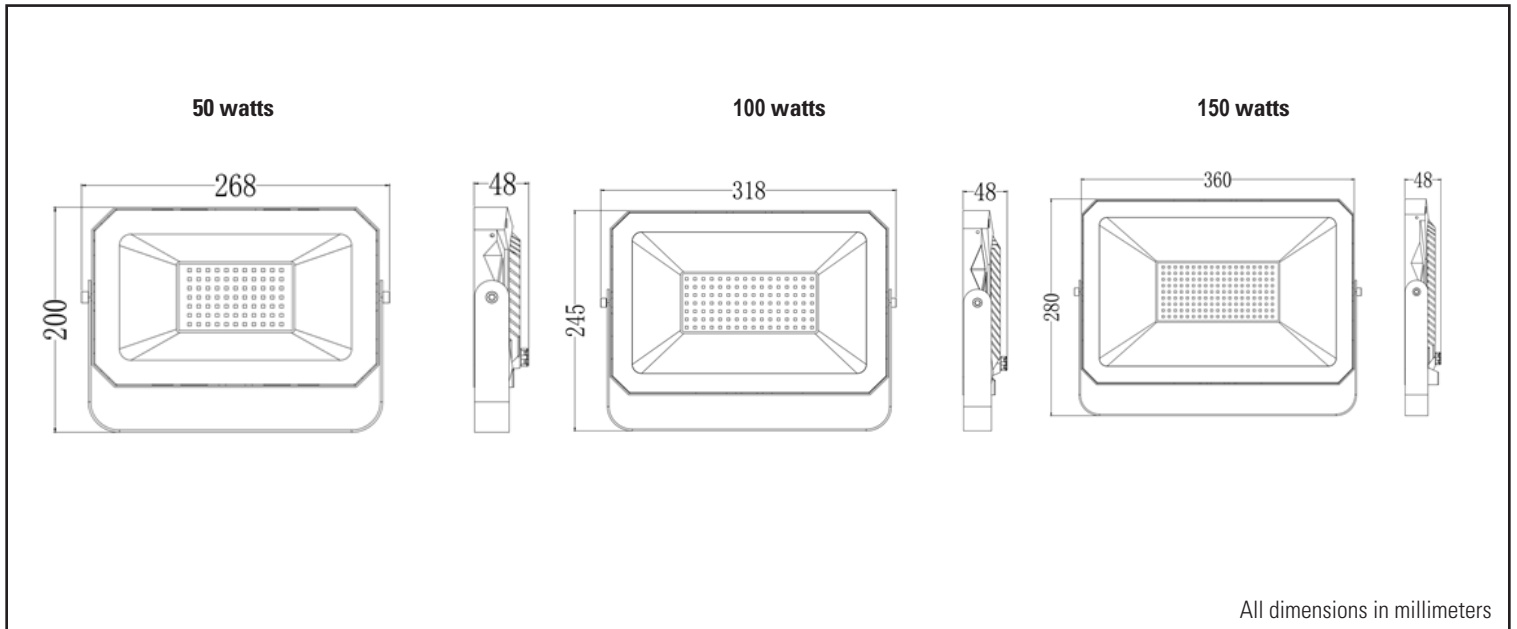

## SPECIFICATIONS

Part Number	Input Power	Input Voltage	Efficiency	CCT	Light Distribution	CRI	Certificates	Warranty
JH-SPL50W-82F	50W	120 VAC	120Lm/W	3000-5700K	120°	75+	UL	5 Years
JH-SPL100W-82F	100W	120 VAC	120Lm/W	3000-5700K	120°	75+	UL	5 Years
JH-SPL150W-82F	150W	120 VAC	120Lm/W	3000-5700K	120°	75+	UL	5 Years