



**VOICE-ASSISTANT  
WIRELESS SPEAKER**



**VA-PWS-6/1154**

**INSTRUCTION MANUAL**

**PLEASE READ ALL INSTRUCTIONS CAREFULLY  
AND RETAIN FOR FUTURE USE**

## **Getting started**

- Remove the product from the box.
- Remove any packaging from the product.
- Please retain all packaging after you have checked and counted all the parts and the contents against the list.

## **Package Contents**

- Bluetooth Speaker
- USB charging cable
- Instruction Manual

## **Key Features**

- Wireless Speaker supports Siri & Google Assistant Voice Commands
- Just press the “Voice Assistant” button to start conversation with your Siri or Google Assistant
- Connects to any Bluetooth enabled devices
- Streams wireless music from your iPhone, iPad and other Android/Windows smartphones and tablets
- Speaker delivers crisp & stereo sound
- Built-in microphone for hands-free calls
- Portable & light weight
- Built-in rechargeable battery

## **Safety Instructions**

Keep the unit away from heat sources, direct sunlight, humidity, water and any other liquids.

Do not operate the unit if it has been exposed to water, moisture or any other liquids to prevent against electric shock, explosion and/or injury to yourself and damage to the unit.

Do not use the unit if it has been dropped or damaged in any way.

Repairs to electrical equipment should only be performed by a qualified electrician. Improper repairs may place the user at serious risk.

Do not use the unit with wet hands.

Do not put objects into any of the openings.

Keep the unit free from dust, lint etc.

Do not use this unit for anything other than its intended use.

Keep the unit out of reach of children.

This product is not a toy.

Do not use the handset at excessive volume levels, as damage to hearing may occur.

## Description of Parts

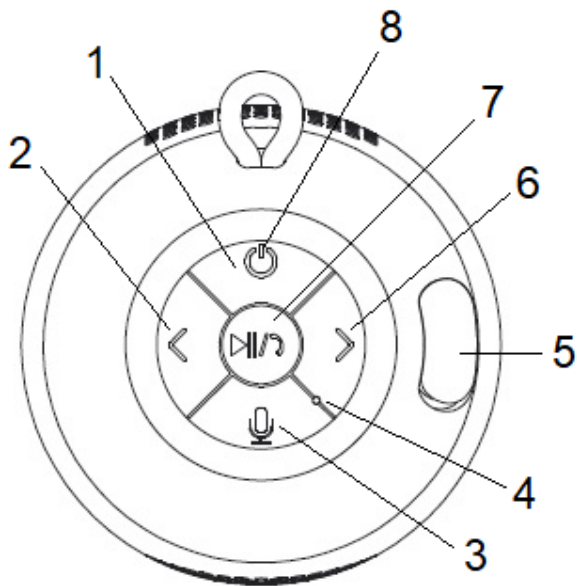
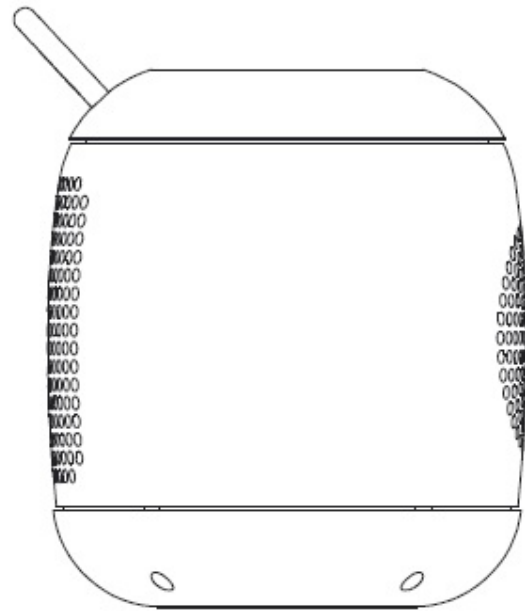
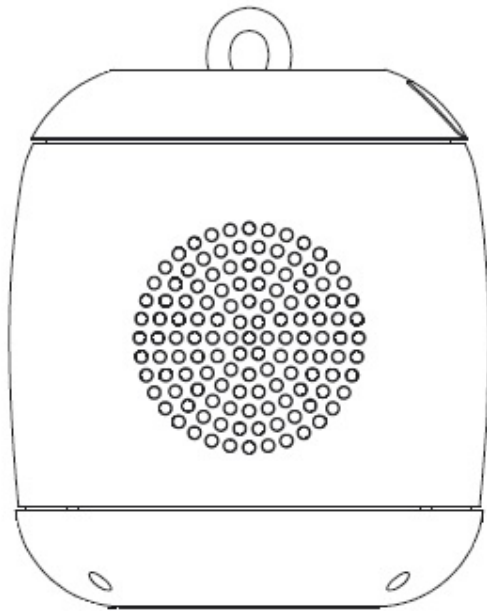

1	LED Light Indicator
2	Volume Decrease / Previous Track
3	Voice Assistant Button
4	Built-in microphone
5	Charging Port (under the protective cover)
6	Volume Increase (+) / Next Track
7	Play/Pause/Phone Button
8	ON/OFF Button

## INSTRUCTIONS FOR USE

### Charging Instructions

The Bluetooth Speaker comes with a built in rechargeable battery. Before using it for the first time we recommend you to charge the battery fully. It takes 3-5 hours to fully charge the battery. Only use the supplied USB Cord to charge the Bluetooth Speaker.

Connect the USB charging cord to a computer USB port and the Micro USB plug to the charging port of the device. The Red LED light turns on while the device is charging. It takes 3-5 hours for the speaker to fully charge. When the battery is fully charged, the LED light will turn off.

### Switching on/off the device

Press and hold the ON/OFF button for 2-3 seconds to turn on/off the device.

### Pairing the device with Bluetooth devices (phone or music device)

Ensure the device is turned off, then press and hold the ON/OFF button for 2-3 seconds to turn on the device, you would hear an indication tone and the LED flashes blue rapidly. Place the Bluetooth Speaker and Bluetooth device (phone or music device) so that they are no further than 3 feet apart;

Activate the Bluetooth function on your Bluetooth device (phone or music device). Please refer to the manufacturer's instructions for instructions on enabling Bluetooth on your device.

Once you have activated Bluetooth on your device, select the **"Audiolux Speaker"** from the list of available Bluetooth devices.

If required, enter the password '0000' to confirm & finalize pairing.

Once paired successful, you would hear another indication tone, and the LED would stay blue.

You can now start to use the device.

If pairing is unsuccessful, turn off the device first and then re-pair following the above steps.

Once you have paired the Bluetooth Speaker with a device, the Speaker will remember this device and will pair automatically when the device's Bluetooth is activated and in range. You do not need to re-pair any previously connected devices.

The Bluetooth Speaker will attempt to automatically connect to the last device it was paired with when switched on. If you want to pair it with a new device, please follow the steps outlined above.

Once the Bluetooth Speaker is paired with your device the music will transmit through the Bluetooth Speaker. Please refer to your device's user manual for further information.

### Making a call with the Bluetooth Speaker in Bluetooth mode

#### Basic operation

Please ensure that you are paired with the Bluetooth Speaker to use the below functions.

Function	Operation	Button
Answer Incoming Call	Incoming Call	Press the <b>Phone</b> once to answer an incoming call.
Reject incoming call	Incoming Call	Press and hold the <b>Phone</b> button
End Call	Incoming Call	After your phone conversation, short press the <b>Phone</b> button
Increase Volume	During a call	Press and hold the Volume Increase button to increase the volume
Decrease Volume	During a call	Press and hold the Volume Decrease button to decrease the volume

Redial last number	Standby mode and connected to a device	Short press the <b>Phone</b> button twice
--------------------	--	---

**Please Note**

- Not all mobile phones support all the functions listed above. Please refer to your cell phone’s user’s manual for further information.
- Certain functions and indication tone maybe vary depending on your mobile phone.

**Listening to Music**

Please ensure that your device (iPhone, Tablet or Other Smart Phone) is paired with the Bluetooth Speaker to stream music wirelessly. Once it is paired, play music from your device.

Function	Operation	Button
Increase Volume	Playing music	Press and hold the Volume Increase button to increase the volume
Decrease Volume	Playing music	Press and hold the Volume Decrease button to decrease the volume
Pause	Playing music	Short press the Play/Pause button will pause the music
Play	Pausing	Short press the Play/Pause button will resume the music
Previous track	Playing music	Short press the Skip Backward button will return you to the previous track
Next track	Playing music	Short press the Skip Forward button will take you to the next track

(Note: An indication tone will alert you when the volume is adjusted to the minimum or maximum level.)

**Voice Assistant Operation**

AudioLux Voice Assistant is a built-in interactive feature that allows you to Start Conversation with Your Siri or Google Assistant, with a click of a button on your AudioLux device.

This feature enables you to ask questions and seek assistance on a number of things from your Voice Assistant, even when you’re several feet away from your phone. Below are some of the many examples listed below.

Note: Google Assistant is available on eligible Android 5.0 devices or later. Works on Lollipop, Marshmallow and Nougat Android Phones with Google Play Services, >1.5GB of memory and 720P or higher screen resolution. Please ensure Google Assistant App is downloaded and made as default Voice Assistant on your mobile device.

**While the speaker is paired using Bluetooth, press the Voice Assistant button to start conversation with your Siri or Google Assistant. An indication tone would be heard before you speak into the speaker.**

- Example 1: Press the Voice Assistant button and then speak into the speaker, how's the weather today?  
Voice Assistant will reply with something like: mainly cloudy with a few showers.
- Example 2: Press the Voice Assistant button, and then speak into the speaker, what's the time now?  
Voice Assistant will reply with something like: it is 8pm now.
- More examples:  
Set an alarm for 7am tomorrow.  
Play some music.  
What's in the news?

### **Tips!!**

When the speaker is not in use, turn it OFF in order to save the battery power.

### **Troubleshooting**

<b>Problem</b>	<b>Possible Cause</b>	<b>Solution</b>
<b>Low sound level</b>	Source (Tablet, Mobile Phone, Laptop, etc.) volume too low. Battery dead	Adjust source volume  Charge Battery
<b>Sound distorted</b>	Battery nearly dead	Charge Battery
<b>No sound at all</b>	Source (Tablet, Mobile Phone, Laptop.) turned off. Speaker turned off. Volume turned down source. Media paused on source.	Turn the source on.  Turn the speaker on. Adjust volume source. Play media from source.
<b>Battery Won't Charge</b>	Charging cable not connected well Charger does not function	Secure the ends of the USB charging cable Try another charging source
<b>Your Google Assistant not responding</b>	Your mobile device does not have Google Assistant App downloaded and set to default voice assistant	This is only available for Android Mobile Devices Make sure Google Assistant is downloaded on your mobile device and set to default voice assistant Make sure your Android Mobile Device is Bluetooth paired with Speaker Make sure you are in a country where Google Assistant is available For additional support, visit <a href="http://www.support.google.com/assistant">www.support.google.com/assistant</a>
<b>Loud Dial Tone Noise When</b>	Old Android Version and possibly not updated	Make sure you have latest version of Google Assistant App

<b>Activating Google Assistant</b>		On your Android mobile device, go to Settings > Apps > Google App > Disable. After that, tap Enable (If you have uninstalled Google App, please uninstall and reinstall the App).
------------------------------------	--	---

## Care and maintenance

Read the following recommendations before using the Bluetooth Speaker. Following these you will be able to enjoy the product for many years.

- Do not expose the unit to liquid, moisture or humidity to avoid the product’s internal circuit being affected.
- Don’t use abrasive cleaning solvents to clean the unit.
- Do not expose the unit to extremely high or low temperature as this will shorten the life of electronic devices, destroy the battery or distort certain plastic parts.
- Don’t dispose of the unit in fire as it will result in an explosion.
- Don’t expose the unit to contact with sharp objects as this will cause scratches and damage.
- Don’t let the unit fall down onto the floor. The internal circuit might get damaged.
- Don’t attempt to disassemble the unit as it may get damaged if you are not professional.

## Specifications –

Bluetooth® Version: 4.2

Wireless Streaming Range: 26-33 Feet

Speaker output: 3W

Size: Dia. 3.6” x H4.0”

Weight: 9.9 Oz approx.

Power Input: DC 5V

Charging Time: 3-5 hours

Play time: up to 4 hours (max. volume)

Built-In Rechargeable Battery: 3.7V / 1200mAh

(Note: Battery life & charging time may vary based on usage, types of devices connected & wireless distance.)

## FCC Instructions

Changes or modifications not expressly approved by the party responsible for compliance could void the user’s authority to operate the product.

NOTE: This product has been tested and found to comply with the limits for a Class B digital device, pursuant to Part 15 of the FCC Rules. These limits are designed to provide reasonable protection against harmful interference in a residential installation. This product generates, uses and can radiate radio frequency energy and, if not installed and used in accordance with the instructions, may cause harmful interference to radio communications. However, there is no guarantee that interference will not occur in a particular installation. If the product does cause harmful interference to radio or television reception, which can be determined by turning the equipment off and on, the user is encouraged to try to correct the interference by one or more of the following measures :

- Reorient or relocate the receiving antenna.
- Increase the separation between the product and receiver.

- Connect the product into an outlet on a circuit different from that to which the receiver is connected.
- Consult the dealer or an experienced radio/TV technician for help.

This device complies with part 15 of the FCC Rules. Operation is subject to the following two conditions: (1) This device may not cause harmful interference, and (2) this device must accept any interference received, including interference that may cause undesired operation.

### **Limited Warranty**

This manufacturer's product warranty extends to the original consumer purchaser of the product. Neither the retailer nor any other company involved in the sale or promotion of this product is a co-warrantor of this manufacturer warranty.

**WARRANTY DURATION:** All materials and workmanship are warranted to the original consumer purchaser for a period of ninety (90) days from the original purchase date.

**WARRANTY COVERAGE:** This product is warranted against defective materials or workmanship. This warranty is void if the product has been damaged by accident, in shipment, unreasonable use, misuse, neglect, improper service, commercial use, repairs by unauthorized personnel or other causes not arising out of defects in materials or workmanship. This warranty is effective only if the product is purchased and operated in USA, and does not extend to any units which have been used in violation of written instructions furnished by manufacturer or to units which have been altered or modified or, to damaged products or parts thereof which have had the serial number removed, altered, defaced or rendered illegible.

**WARRANTY DISCLAIMERS:** This warranty is in lieu of all warranties expressed or implied and no representative or person is authorized to assume for manufacturer any other liability in connection with the sale of our products. There shall be no claims for defects or failure under any theory of tort, contractor commercial law including but not limited to, negligence, gross negligence, strict liability, breach of warranty and breach of contract. Under no circumstances will Manufacturer's / Distributor's maximum liability exceed the retail value of the product.

**WARRANTY PERFORMANCE:** During the above 90 day warranty period, a product with a defect will be either repaired or replaced with a reconditioned comparable model (at manufacturer's option). The repaired or replacement product will be in warranty for the balance of the 90 day warranty period and an additional one-month period. No charge will be applicable for such repair or replacement.

**SERVICE AND REPAIR:** If service is required for this product, you should first contact Midwest Trading Group Customer Service at [info@mtradinggroup.com](mailto:info@mtradinggroup.com) or by calling 1 (866) 815-4714, Monday to Friday 10am to 6pm EST.

**NOTE:** Manufacturer cannot assume responsibility for loss or damage during incoming shipment. As a precautionary measure, carefully package the product for shipment, and insure it with the carrier. Be sure to enclose the following details with the product: your full name, return address and daytime phone number, a note describing the problem you experienced, a copy of your sales receipt or other proof of purchase to determine warranty status. C.O.D. shipments cannot be accepted.