

FIXIT Setbacks

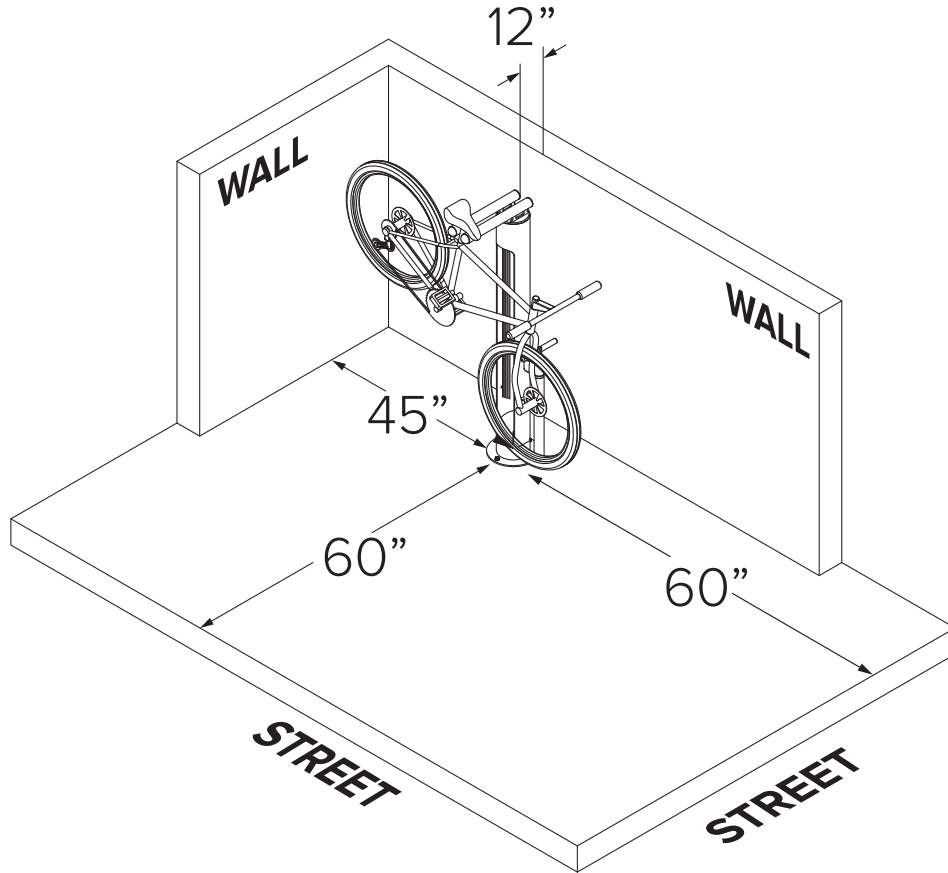

An optional wheel catch is available to hold bikes with no kick stands

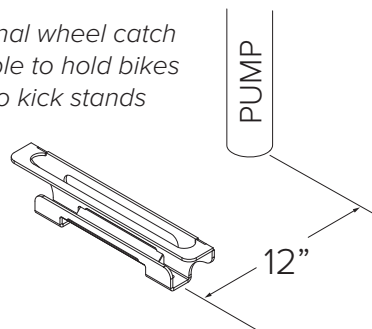

DERO
A PLAYCORE Company

www.dero.com | 1-888-337-6729

FIXIT

Installation Instructions – Surface Mount

TOOLS NEEDED

Hammer drill
3/8" masonry bit
Hammer
Socket Wrench
9/16" socket
Tamper-proof socket (included)*
Socket extension, 6" min.
*Keep tool for future maintenance

RECOMMENDED BASE MATERIAL

Solid concrete is the best base material for installation. To ensure the proper anchors are shipped with your rack, ask your Dero Rack representative which anchor is appropriate for your application. Be sure nothing is underneath the base material that could be damaged by drilling.

1

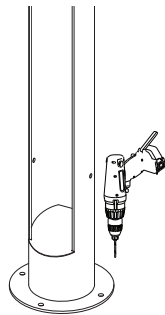

Reference the Fixit setback recommendations and place the upright in the desired location. Use the base as a template and drill (4) 3/8" x 3" holes in the concrete with a hammer drill and masonry bit. Clean up all concrete dust from drilling.

2

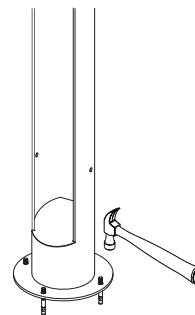

Hammer in the (4) wedge anchors. Leave at least 3/4" of an inch of exposed threads above the Fixit base.

3

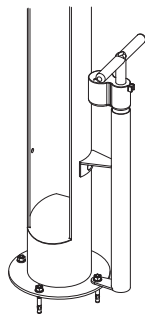

Decide which position the pump will be installed in and place the bottom pump flange over the corresponding wedge anchor. Attach the top pump flange to the Fixit upright with a carriage bolt, washer, and tamper-proof nut. Tighten all wedge anchors with washers and nuts.

4

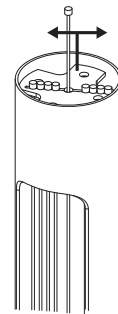

Insert the tool cables into the cable slot on the Fixit upright.



DERO
A PLAYCORE Company

www.dero.com | 1-888-337-6729

FIXIT

Installation Instructions – Surface Mount

5

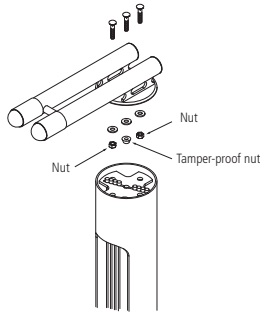

Place the bike hanger in the desired position on top of the Fixit upright and attach with carriage bolts, washers and nuts.

After installation is complete, please scan the QR code on the Fixit with a smartphone. This will allow us to add this Fixit station to our map available here:

<http://www.dero.com/fixitmap/fixitmap.html>

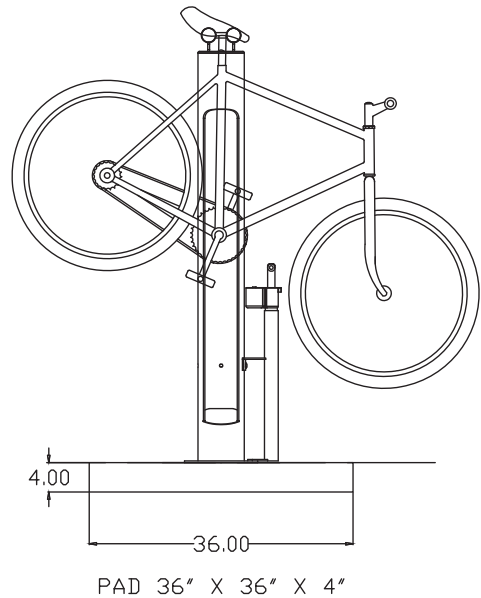
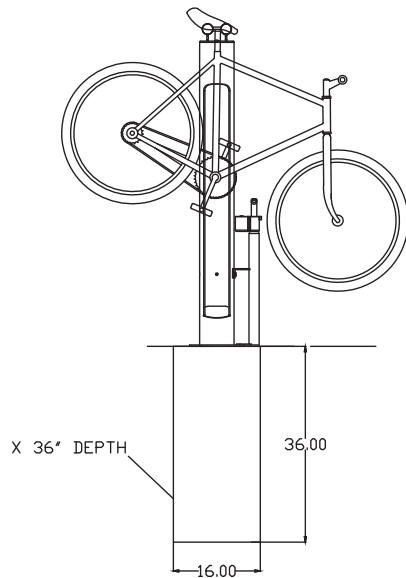

Pad recommendations for pouring along trail



DERO
A PLAYCORE Company

www.dero.com | 1-888-337-6729

FIXIT

Installation Instructions – In Ground Mount

1

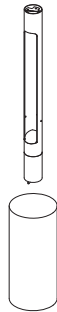

Pour a 16" diameter by 36" deep concrete footing. Place the Fixit in the footing centered and plumb.

2

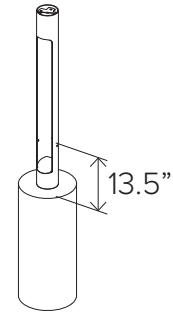

The surface of the concrete to the hole on the side of the Fixit should be 13.25". Support the Fixit and let the concrete set.

3

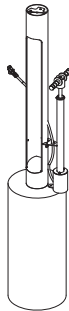

Decide which position the pump will be installed and hold it in place while marking where the anchor will go in the concrete. Drill a 3/8" x 3" hole in the concrete with a hammer drill and masonry bit. Clean up all concrete dust from drilling. Hammer in the wedge anchor with an inch of threads exposed above the concrete.

4

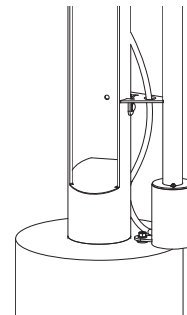

Place (2) 3/8" washers over the exposed wedge anchor threads and then place the pump mounting flange over the wedge anchor. Secure with a 3/8" washer and nut. Then secure the upper pump mount to the Fixit with a 3/8" x 3/4" carriage bolt, washer, and tamper-proof nut.



DERO
A PLAYCORE Company

www.dero.com | 1-888-337-6729

FIXIT

Installation Instructions – In Ground Mount

5

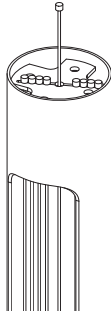

Insert the tool cables into the cable slot on the Fixit upright.

6

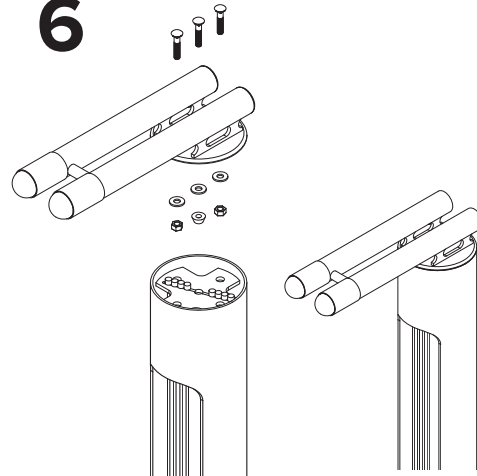

Place the bike hanger in the desired position on top of the Fixit upright and attach with carriage bolts, washers and nuts.



DERO
A PLAYCORE Company

www.dero.com | 1-888-337-6729

FIXIT

Maintenance and Replacement

NOTE:

All threads for all parts of the pump are right-hand threads. They tighten clockwise, and loosen counter-clockwise ("righty tighty, lefty loosey"). However, when you are looking top-down at a bolt that threads from underneath, if you move it counter-clockwise from your point of view, you are actually tightening, not loosening, the nut! This has led to some unnecessary breakage of pump parts. Be sure you are looking at the nut with the proper orientation before tightening or loosening.

REMOVING THE AIR KIT FROM THE FIXIT

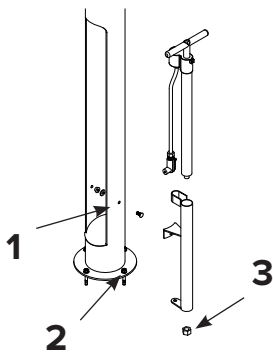

- 1.** Remove nut and bolt on side of Fixit.
- 2.** Remove tamperproof nut on bottom of Fixit, using the Tamperproof Penta Tool supplied for this purpose.
- 3.** Once Airpump is removed, but still in sleeve, remove the 1 3/16" nut on the bottom of the sleeve (turning counter-clockwise). You can now slide the pump out.

CHANGING THE PUMPHEAD

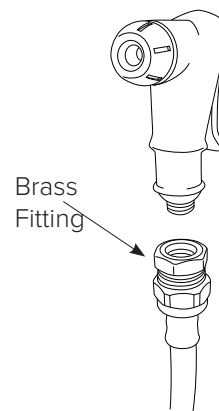

Remove the shrinkwrap. Unscrew the pumphead from the brass fitting (turning counter-clockwise). You will need to keep the brass fitting for the new pumphead. Replace the pumphead. If you want to put on shrinkwrap, then put the shrinkwrap sleeve over the hose before replacing pumphead. Once pumphead is on, pull shrinkwrap sleeve over the brass fitting and use a heatgun to shrink it.

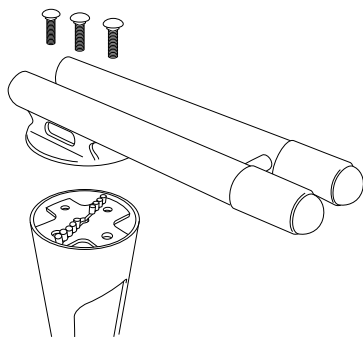

REPLACING TOOLS

There are three bolts at the top of the Fixit. Underneath are two 3/8" nuts, and one penta tamperproof nut. These are all best removed with a socket wrench, using the extension tool to enable you to reach the nuts. Once the nuts are removed, take off the cap to replace tools.



DERO
A PLAYCORE Company

www.dero.com | 1-888-337-6729