

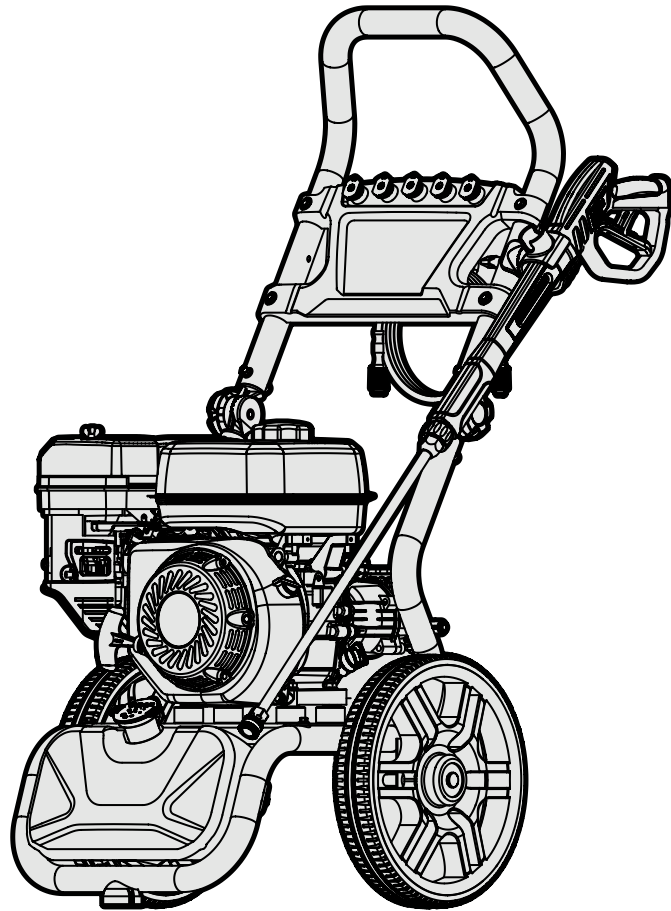

MODEL PW224G

3400-PSI PRESSURE WASHER

Instruction Manual



NEED HELP? CONTACT US!

Have product questions? Need technical support? Please feel free to contact us:



1-847-429-9263 (M-F 8AM-5PM CST)



TECHSUPPORT@WENPRODUCTS.COM

IMPORTANT: Your new tool has been engineered and manufactured to WEN's highest standards for dependability, ease of operation, and operator safety. When properly cared for, this product will supply you years of rugged, trouble-free performance. Pay close attention to the rules for safe operation, warnings, and cautions. If you use your tool properly and for its intended purpose, you will enjoy years of safe, reliable service.

For replacement parts and the most up-to-date instruction manuals, visit ***WENPRODUCTS.COM***

CONTENTS

WELCOME	3
Specifications.....	3
Introduction	4
SAFETY	5
General Safety Rules.....	5
Pressure Washer Safety Warnings.....	7
BEFORE OPERATING	9
Know Your Pressure Washer	9
Unpacking & Packing List.....	10
Assembly & Adjustments.....	11
OPERATION & MAINTENANCE	15
Operation	15
Maintenance.....	18
Transportation & Storage.....	23
Troubleshooting Guide.....	24
Exploded View & Parts List.....	25
Warranty Statement	30

To purchase accessories and replacement parts for your tool, visit **WENPRODUCTS.COM**

Universal Weatherproof Pressure Washer Cover (Model PW31C)

Magnetic Oil Dipstick (Model 55201)

SPECIFICATIONS

PRESSURE WASHER

Model Number	PW224G
Maximum Pressure	3400 PSI
Rated Pressure	2850 PSI
Maximum Flow	2.7 GPM
Rated Flow	2.4 GPM
Nozzles	0°, 15°, 25°, 40°, Soap
Maximum Inlet Pressure	101 PSI
Gun to Lance Connection	M22 Thread, 14mm Connector
Gun to Hose Connection	M22 Thread, 14mm Connector
Lance	21.38 in. Stainless Steel
Lance to Nozzle Connection	Quick Change
Pump	Axial Cam
Detergent Tank Capacity	128.51 fl. oz. (3.8L)
Minimum Garden Hose Inner Diameter	5/8 in.
High Pressure Hose Inner Diameter	1/4 in.
Hose Length	25 ft.
Wheel Diameter	12 in.
Product Weight	70 lbs.
Product Dimensions	23.62 in. x 20.47 in. x 43.15 in.

ENGINE

Engine Type	4 Stroke, OHV, Single Cylinder with Forced Air Cooling System
Spark Plug Gap	0.7mm - 0.8mm (0.028 in. - 0.031 in.)
Spark Plug Torque	20 - 24 Nm (14.8 - 17.7 ft-lb)
Displacement	223cc
Fuel Tank Capacity	0.7 Gallon (2.8L)
Oil Capacity	17.0 fl. oz. (500 mL)
Lubrication System	Splash Lubrication
Noise Rating (No Load at 13 Feet)	108 dB
Noise Rating (Full Load at 13 Feet)	110.2 dB
Spark Plug	Torch F6TC (NGK BP6ES)

INTRODUCTION

Thanks for purchasing the WEN 3400 PSI Pressure Washer. Refer to the illustration below for the location of the serial number on the specifications label. Record the pressure washer information in the spaces provided below. If assistance for information or service is required, please contact customer service by calling **1-847-429-9263**, M-F 8-5 CST; you will be asked to provide the following pressure washer information when calling.

Pressure Washer Model Number: PW224G

Date of Purchase: _____

Purchased From: _____

Serial Number: _____

3400 PSI PRESSURE WASHER		MODEL PW224G
PRESSURE	2850 PSI (RATED), 3400 PSI (MAX)	PROP 65 WARNING: The engine exhaust from this product contains chemicals known to the State of California to cause cancer and birth defects or other reproductive harm.
FLOW RATE	2.4 GPM (RATED), 2.7 GPM (MAX)	
FUEL TANK CAPACITY	0.7 GAL. (2.7L)	
SOAP TANK	1 GAL. (3.8 L)	
SERIAL NUMBER	<div style="display: flex; justify-content: space-between; width: 100%;"> </div>	
1-847-429-9263 WENPRODUCTS.COM <small>Great Lakes Technologies LLC • 1101 Wesemann Drive • West Dundee, IL 60118</small>		TYPE 1 LAVEUSE À PRESSION ÉLECTRIQUE MADE IN USA OF IMPORTED COMPONENTS

→ Serial Number

SERVICE RECORD

Record the service dates of your pressure washer in the chart below. Please perform maintenance checks and operations according to the "Maintenance" section of the manual.

Service Record	Date	Date	Date	Date	Date	Date
Change Oil						
Change Spark Plug						
Clean Fuel Tank						
Clean Air Cleaner						
Clean Spark Arrestor						

GENERAL SAFETY RULES

 **WARNING!** Read all safety warnings and all instructions. Failure to follow the warnings and instructions may result in electric shock, fire and/or serious injury.

Safety is a combination of common sense, staying alert and knowing how your item works. The term “power tool” in the warnings refers to your mains-operated (corded) power tool or battery-operated (cordless) power tool.

SAVE THESE SAFETY INSTRUCTIONS.

WORK AREA SAFETY

- 1. Keep work area clean and well lit.** Cluttered or dark areas invite accidents.
- 2. Do not operate power tools in explosive atmospheres, such as in the presence of flammable liquids, gases or dust.** Power tools create sparks which may ignite the dust or fumes.
- 3. Keep children and bystanders away while operating a power tool.** Distractions can cause you to lose control.

ELECTRICAL SAFETY

- 1. Power tool plugs must match the outlet. Never modify the plug in any way. Do not use any adapter plugs with earthed (grounded) power tools.** Unmodified plugs and matching outlets will reduce risk of electric shock.
- 2. Avoid body contact with earthed or grounded surfaces such as pipes, radiators, ranges and refrigerators.** There is an increased risk of electric shock if your body is earthed or grounded.
- 3. Do not expose power tools to rain or wet conditions.** Water entering a power tool will increase the risk of electric shock.
- 4. Do not abuse the cord. Never use the cord for carrying, pulling or unplugging the power tool. Keep cord away from heat, oil, sharp edges or moving parts.** Damaged or entangled cords increase the risk of electric shock.
- 5. When operating a power tool outdoors, use an extension cord suitable for outdoor use.** Use of a cord suitable for outdoor use reduces the risk of electric shock.

- 6. If operating a power tool in a damp location is unavoidable, use a ground fault circuit interrupter (GFCI) protected supply.** Use of a GFCI reduces the risk of electric shock.

PERSONAL SAFETY

- 1. Stay alert, watch what you are doing and use common sense when operating a power tool. Do not use a power tool while you are tired or under the influence of drugs, alcohol or medication.** A moment of inattention while operating power tools may result in serious personal injury.
- 2. Use personal protective equipment. Always wear eye protection.** Protective equipment such as a respiratory mask, non-skid safety shoes and hearing protection used for appropriate conditions will reduce the risk of personal injury.
- 3. Prevent unintentional starting. Ensure the switch is in the off-position before connecting to power source and/or battery pack, picking up or carrying the tool.** Carrying power tools with your finger on the switch or energizing power tools that have the switch on invites accidents.
- 4. Remove any adjusting key or wrench before turning the power tool on.** A wrench or a key left attached to a rotating part of the power tool may result in personal injury.
- 5. Do not overreach. Keep proper footing and balance at all times.** This enables better control of the power tool in unexpected situations.
- 6. Dress properly. Do not wear loose clothing or jewelry. Keep your hair and clothing away from moving parts.** Loose clothes, jewelry or long hair can be caught in moving parts.

GENERAL SAFETY RULES

 **WARNING!** Read all safety warnings and all instructions. Failure to follow the warnings and instructions may result in electric shock, fire and/or serious injury.

Safety is a combination of common sense, staying alert and knowing how your item works. The term “power tool” in the warnings refers to your mains-operated (corded) power tool or battery-operated (cordless) power tool.

SAVE THESE SAFETY INSTRUCTIONS.

7. If devices are provided for the connection of dust extraction and collection facilities, ensure these are connected and properly used. Use of dust collection can reduce dust-related hazards.

POWER TOOL USE AND CARE

1. Do not force the power tool. Use the correct power tool for your application. The correct power tool will do the job better and safer at the rate for which it was designed.

2. Do not use the power tool if the switch does not turn it on and off. Any power tool that cannot be controlled with the switch is dangerous and must be repaired.

3. Disconnect the plug from the power source and/or the battery pack from the power tool before making any adjustments, changing accessories, or storing power tools. Such preventive safety measures reduce the risk of starting the power tool accidentally.

4. Store idle power tools out of the reach of children and do not allow persons unfamiliar with the power tool or these instructions to operate the power tool. Power tools are dangerous in the hands of untrained users.

5. Maintain power tools. Check for misalignment or binding of moving parts, breakage of parts and any other condition that may affect the power tool's operation. If damaged, have the power tool repaired before use. Many accidents are caused by poorly maintained power tools.

6. Keep cutting tools sharp and clean. Properly maintained cutting tools with sharp cutting edges are less likely to bind and are easier to control.

7. Use the power tool, accessories and tool bits, etc. in accordance with these instructions, taking into account the working conditions and the work to be performed. Use of the power tool for operations different from those intended could result in a hazardous situation.

8. Use clamps to secure your workpiece to a stable surface. Holding a workpiece by hand or using your body to support it may lead to loss of control.

9. KEEP GUARDS IN PLACE and in working order.

SERVICE

1. Have your power tool serviced by a qualified repair person using only identical replacement parts. This will ensure that the safety of the power tool is maintained.

CALIFORNIA PROPOSITION 65 WARNING

Some dust created by power sanding, sawing, grinding, drilling, and other construction activities may contain chemicals, including lead, known to the State of California to cause cancer, birth defects, or other reproductive harm. Wash hands after handling. Some examples of these chemicals are:

- Lead from lead-based paints.
- Crystalline silica from bricks, cement, and other masonry products.
- Arsenic and chromium from chemically treated lumber.

Your risk from these exposures varies depending on how often you do this type of work. To reduce your exposure to these chemicals, work in a well-ventilated area with approved safety equipment such as dust masks specially designed to filter out microscopic particles.

PRESSURE WASHER SAFETY WARNINGS

DANGER! CARBON MONOXIDE

Using a pressure washer indoors **CAN KILL YOU IN MINUTES**. Pressure washer exhaust contains carbon monoxide (CO). This is a poison gas you cannot see or smell. If you can smell the pressure washer exhaust, you are breathing CO. But even if you cannot smell the exhaust, you could be breathing CO.



NEVER use a pressure washer inside homes, garages, crawl spaces, or other partially enclosed areas. Deadly levels of carbon monoxide can build up in these areas. Using a fan or opening windows and doors does NOT supply enough fresh air. **ONLY** use a pressure washer outside and far away from windows, doors, and vents. These openings can pull in pressure washer exhaust.

Even if you use a pressure washer correctly, CO may leak into the home. **ALWAYS** use a battery-powered or battery-backup CO alarm in the home. If you start to feel sick, dizzy, or weak after the pressure washer has been running, move to fresh air **RIGHT AWAY**. See a doctor. You may have carbon monoxide poisoning.

 **WARNING! RISK OF EXPLOSION. HIGHLY FLAMMABLE:** This pressure washer may emit highly flammable and explosive gasoline vapors, which can cause severe burns or even death, if ignited. A nearby open flame can lead to explosion even if not directly in contact with gasoline.

- Do not operate near open flame, heat, or any other ignition source. Do not smoke near the pressure washer.
- Always operate on a firm, level surface.
- Always turn the pressure washer off before refueling. Allow the pressure washer to cool for at least 2 minutes before removing the fuel cap. Loosen the cap slowly to relieve pressure in the tank.
- Do not overfill the fuel tank. Gasoline may expand during operation. Do not fill to the top of the tank. Allow for expansion. Always check for spilled fuel before operating.
- If fuel spills, move the pressure washer at least 30 feet away from the spill and wipe clean any spilled fuel before starting the engine.
- Empty the fuel tank before storing or transporting the pressure washer.

 **CALIFORNIA PROPOSITION 65 WARNING:** This product contains chemicals and produces exhaust known to the State of California to cause cancer, birth defects and other reproductive harm. For more information, visit www.P65Warnings.ca.gov

PRESSURE WASHER SAFETY WARNINGS

 **WARNING!** Do not let comfort or familiarity with the product replace strict adherence to product safety rules. Failure to follow the safety instructions may result in serious personal injury.

OPERATING ENVIRONMENT

- 1. Using the pressure washer indoors can kill you in minutes.** Only use the pressure washer outside and far away from windows, doors and vents.
- 2. Do not smoke near the pressure washer.**
- 3. Do not operate near open flame, heat, or flammable materials.** This pressure washer may emit highly flammable and explosive gasoline vapors, which can cause severe burns or even death if ignited. A nearby open flame can lead to an explosion even if it isn't directly in contact with gasoline.
- 4. Always operate the pressure washer on a firm, level surface.**
- 5. The pressure washer should have at least 5 feet of clearance from buildings or other equipment during operation.**
- 6. Do not allow children or non-qualified persons to operate the pressure washer.**

PRESSURE WASHER OPERATION

- 1. Do not touch hot surfaces.** Pay attention to warning labels on the pressure washer identifying hot parts on the machine.
- 2. Allow the pressure washer to cool down after use before touching the engine or areas of the pressure washer that become hot during operation.**
- 3. Turn the engine switch to the "OFF" position when the engine is not running.**

4. The high pressure stream of water can cut through skin and cause serious injury. Do not aim the stream of water at yourself or at any one else, including animals.

5. Hoses and tubes can become damaged from coming in contact with a hot engine or muffler. Always double check the hose for perforations before starting up the machine and keep it clear of the engine and the muffler.

6. Kickback from operation can cause the user to fall down. Always operate the pressure washer on a level and non-elevated surface to prevent the risk of falling.

7. Always wear safety goggles to protect from possible mishaps with the stream or detergents. Always be aware of the dangers associated with the detergents and chemicals that you are working with. Attach all hoses before starting the engine.

8. Pressure washers vibrate in normal use. During and after the use of the pressure washer, inspect both the pressure washer as well as extension and power supply cords for damage resulting from vibration. Have damaged items repaired or replaced as necessary. Do not use plugs or cords that show signs of damage such as broken or cracked insulation or damaged blades.

SAVE THESE INSTRUCTIONS – This manual contains important instructions for the WEN® Pressure Washer that should be followed during installation and maintenance of the pressure washer.

KNOW YOUR PRESSURE WASHER

TOOL PURPOSE

Easily remove dirt and grime from your deck, siding, and driveway with your WEN Pressure Washer. Refer to the following diagrams to become familiarized with all the parts and controls of your pressure washer. The components will be referred to later in the manual for assembly and operation instructions.

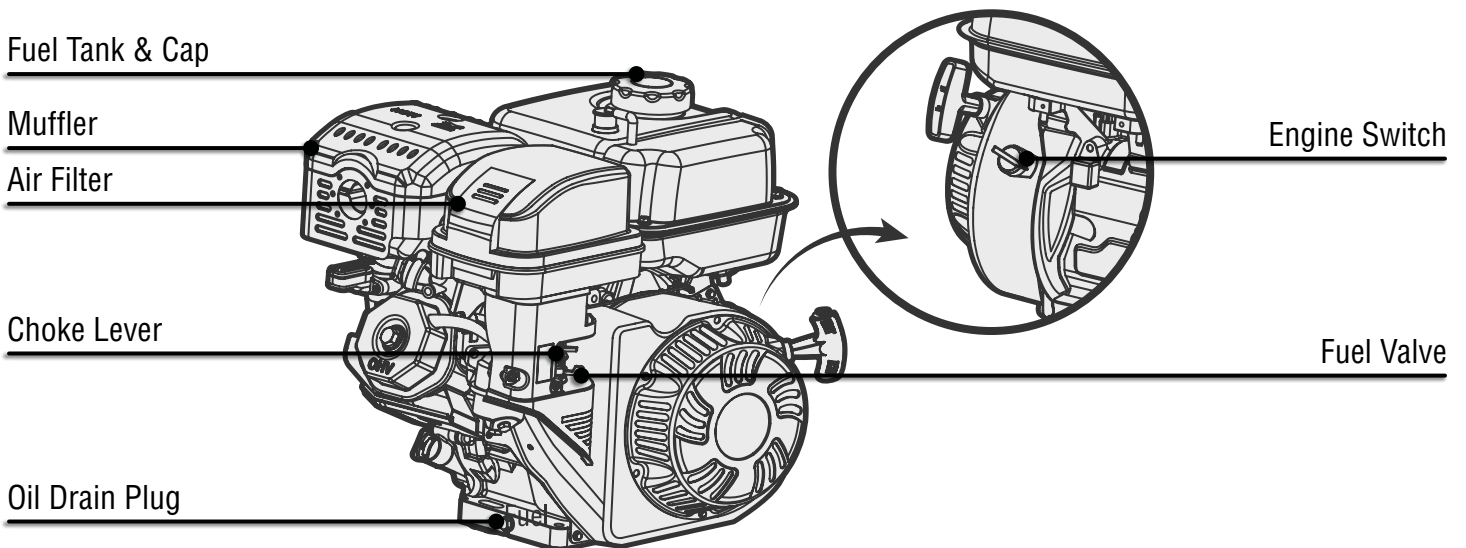
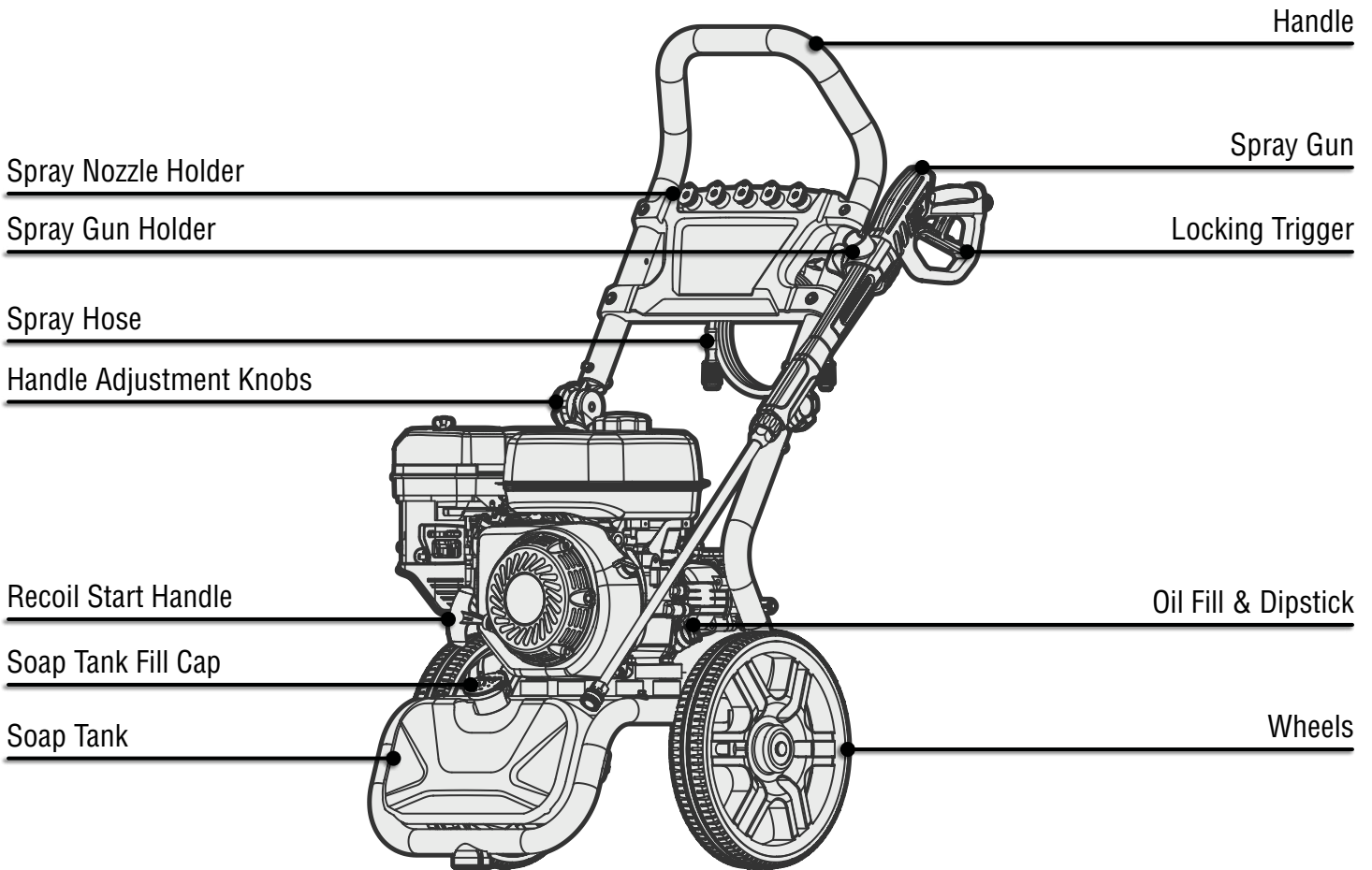

UNPACKING & PACKING LIST

UNPACKING

With the help of a friend or trustworthy foe, such as one of your in-laws, carefully remove the pressure washer from the packaging and place it on a sturdy, flat surface. Make sure to take out all contents and accessories. Do not discard the packaging until everything is removed. Check the packing list below to make sure you have all of the parts and accessories. If any part is missing or broken, please contact customer service at **1-847-429-9263** (M-F 8-5 CST), or email techsupport@wenproducts.com.

PACKING LIST

1. High Pressure Hose	1
2. Spray Gun	1
3. Spray Wand	1
4. Handle.....	1
5. Spray Nozzles	5
6. Funnel	1
7. Wheels	2

BAG ONE

1. High Pressure Hose Hook.....	1
2. Spray Gun Holder.....	1
3. M6x40 Hex Bolts.....	2
4. Washers.....	2
5. Hex Locking Nuts.....	2
6. 8mm/10mm Wrenches	2
7. Spark Plug Wrench	1
8. Axel Pins	2
9. R-Clips	2

BAG TWO

1. User Manual.....	1
2. Nozzle Cleaning Tool	1

 **WARNING!** Do not attempt to assemble or operate this pressure washer until you have read and understood this entire manual. If you have any problems assembling or operating this unit, please call **1-847-429-9263** M-F 8-5 CST for customer service.

 **WARNING!** Do not operate this pressure washer if any of the parts are damaged or missing until the part is replaced. Using this product with damaged or missing parts can cause damage to the machine or result in serious injury or death.

ASSEMBLY & ADJUSTMENTS

INSTALLING THE HANDLE

1. Secure the handle to the frame by using two M6x40 hex bolts (Fig. 1 - 1), two flat washers (Fig. 1 - 2), and two hex locking nuts (Fig. 1 - 3) as shown in Fig. 1.

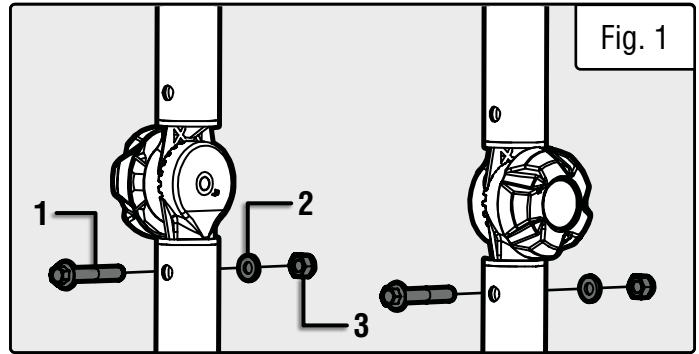

INSTALLING THE SPRAY GUN HOLDER

1. Align the spray gun holder (Fig. 2 - 1) with the mounting hole on the frame as shown in Fig. 2. Make sure that the spray gun holder sits flush against the frame.

2. Adjust the spray gun holder to the desired angle.

3. Secure the spray gun holder to the frame using the spray gun holder lock knob (Fig. 2 - 2). The lock knob comes pre-installed on the holder.

NOTE: You may install the spray gun holder on either side of the frame. However, if it is installed on the right side of the frame, be careful to not let the spray gun come in contact with the muffler, which gets very hot during operation.

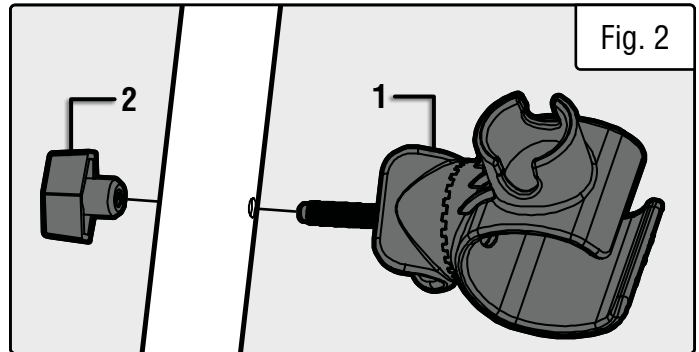

INSTALLING THE HOSE HOOK

1. Secure the hose hook (Fig. 3 - 1) to the back of the panel by fitting the ends through the mounting holes as shown in Fig. 3.

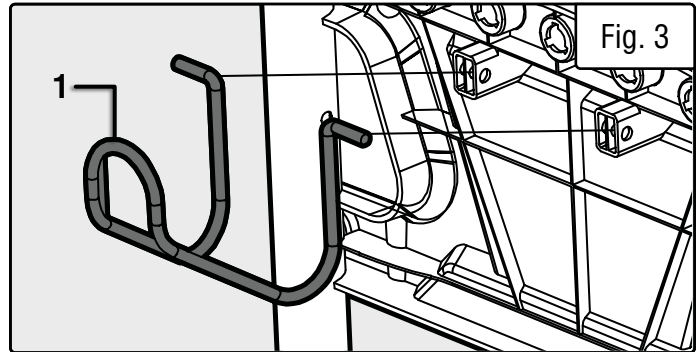

INSTALLING THE WHEELS

1. Align the hole in the middle of the wheel (Fig. 4 - 1) with the mounting holes on the frame as shown in Fig. 4.

2. Slide the axle pin (Fig. 4 - 2) through the wheel and mounting holes.

3. Lock the axle pin in place by sliding the R-clip (Fig. 4 - 3) through the hole in the pin.

4. Repeat steps 1 - 3 for the other wheel.

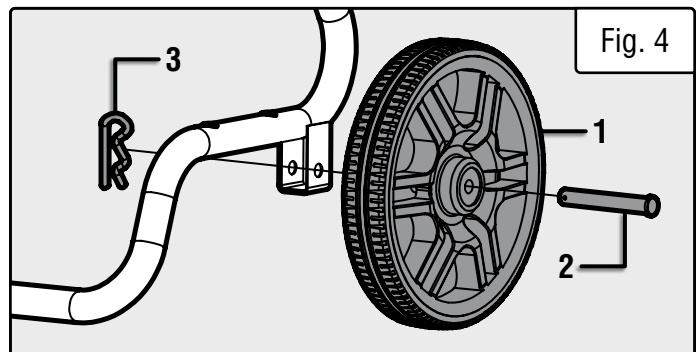

ASSEMBLY & ADJUSTMENTS

ADDING ENGINE OIL

The pressure washer is shipped without oil. User must add the proper amount of oil before operating the pressure washer for the first time. The oil capacity of the engine crankcase is 17 fl. oz. (500 mL). For general use (above 40° F), we recommend 30W, 4-stroke engine oil.

ENGINE OIL RECOMMENDATIONS

Select good quality detergent oil bearing the American Petroleum Institute (API) service classifications SJ, SL, or SM. (Synthetic oils may be used.) Use the SAE viscosity grade of oil from the above chart that matches the starting temperature anticipated before the next oil change.

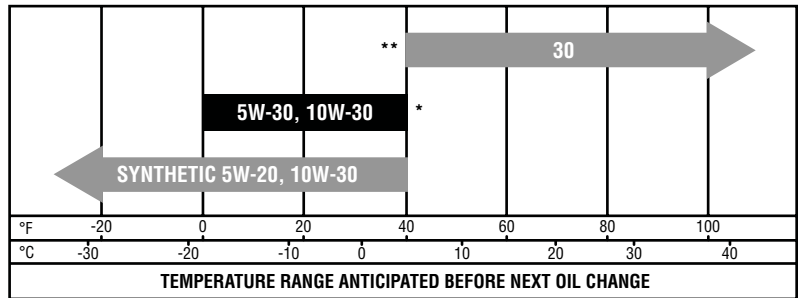

To add oil, follow these steps:

1. Make sure the pressure washer is on a level surface. Tilting the pressure washer to assist in filling will cause oil to flow into the wrong areas of the engine and will cause damage. Keep pressure washer level.
2. Remove the dipstick (Fig. 5 - 1) from the engine.
3. Add oil slowly to bring level to full. Make sure oil comes approximately halfway up the crankcase threads to ensure enough oil has been added.
4. **To check the oil level:** Wipe the dipstick with a clean rag. Insert the dipstick into the oil fill opening without screwing it in. Remove the dipstick to check the oil mark. (Fig. 6)
5. Slowly add more oil and repeat step 4 until the oil mark reaches to the top of the dipstick. Do not over fill the crankcase.
6. Check for oil leaks. Tighten dipstick firmly.

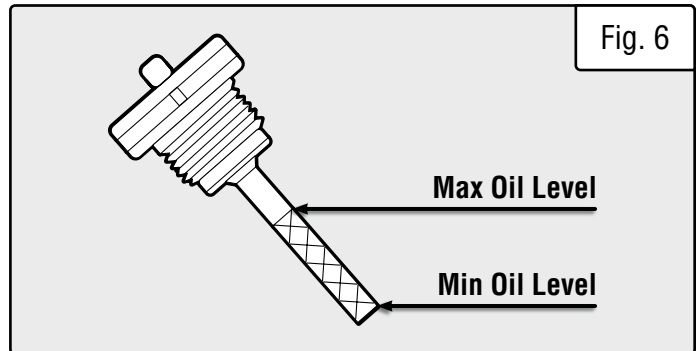
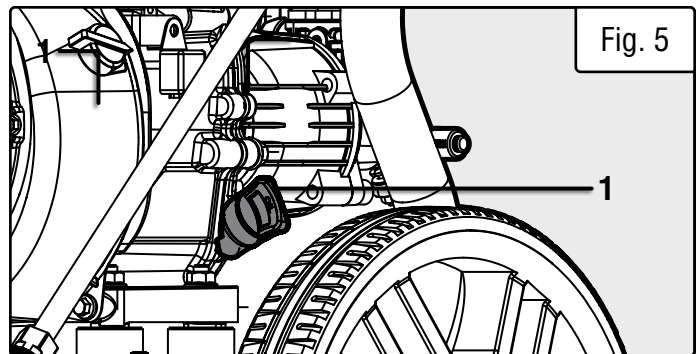

NOTE: Your pressure washer is compatible with the WEN **55201** magnetic oil dipstick, which is available for purchase at wenproducts.com.

ASSEMBLY & ADJUSTMENTS

ADDING GASOLINE

⚠ WARNING! This pressure washer may emit highly flammable and explosive gasoline vapors, which can cause severe burns or even death if ignited. A nearby open flame can lead to explosion even if not directly in contact with gasoline.

Use fresh (within 30 days from purchase), lead-free gasoline with a minimum of 87 octane rating. Do not mix oil with gasoline.

To add gasoline, follow these steps:

1. Make sure the pressure washer is on a level surface.
2. Unscrew fuel cap (Fig. 7 - 1) and set aside.

NOTE: The fuel cap may be tight and hard to unscrew.

3. Slowly add unleaded gasoline to the fuel tank. Be careful not to overfill. The capacity of the fuel tank is 0.7 gallons.

NOTE: Do not fill the fuel tank to the very top. Gasoline will expand and spill over during use even with the fuel cap in place.

4. Reinstall fuel cap and wipe clean any spilled gasoline with a dry cloth.

IMPORTANT:

- Never use an oil/gasoline mixture.
 - Only use unleaded gasoline.
 - Never use old gasoline.
 - Avoid getting dirt or water into the fuel tank.
 - Gasoline can age in the tank and make starting difficult.
- Never store pressure washer for extended periods of time with fuel in the tank.

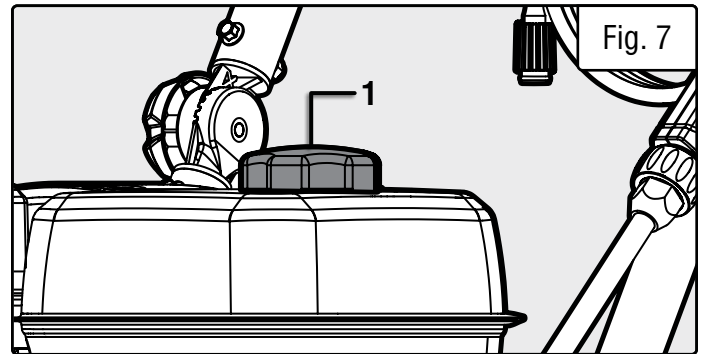

HIGH ALTITUDE OPERATION ABOVE 3000 FEET

The fuel system on this pressure washer may be affected by operation at high altitudes. Proper operation can be ensured by installing an altitude kit at altitudes higher than 3000 feet above sea level. At elevations above 8000 feet, the engine may experience a decrease in performance, even with the proper altitude kit. Operating this pressure washer without said kit may increase the engine's emissions and decrease both fuel economy and performance. You can order the kits at wenproducts.com by searching part numbers **PW224G-HA36 (3000 - 6000 ft)** or **PW224G-HA68 (6000 - 8000 ft)**. This kit should be installed by a qualified mechanic. Refer to the instructions included with your altitude kit for more information about installation.

⚠ WARNING! To prevent serious injury from fire, follow the kit installation procedures in a well-ventilated area away from ignition sources. If the engine is hot from use, shut the engine off and let it cool before proceeding. Do not smoke near the pressure washer. Warranty will be void if adjustments are not made for high altitude use.

⚠ CAUTION! Operating engines at lower altitudes with the high-altitude kit installed could cause severe engine damage and affect emissions compliance. Be sure to uninstall the high altitude kit when operating at altitudes below 3000 feet.

ASSEMBLY & ADJUSTMENTS

ASSEMBLING THE SPRAY GUN

1. Screw the spray wand (Fig. 8 - 1) and the trigger handle (Fig. 8 - 2) together clockwise until they are secure.
2. Insert the inlet coupler of the high-pressure hose (Fig. 9 - 1) into the threaded fitting on the spray gun (Fig. 9 - 2) and thread the black nut on by turning it clockwise until it is hand tight.

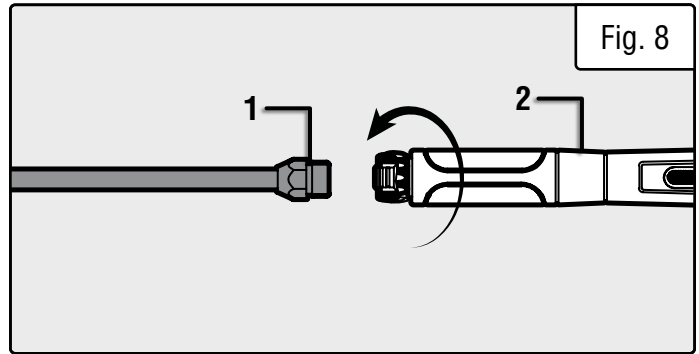

CONNECTING THE HIGH PRESSURE HOSE

1. Attach the end of the high pressure hose to the high pressure outlet (Fig. 10 - 1) on the pump.
2. Follow the same procedure with opposite end to attach high pressure hose to spray wand.

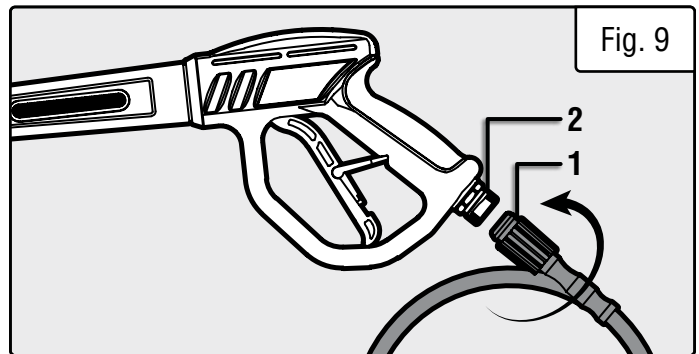

CONNECTING THE GARDEN HOSE

1. Run water through the hose for a few seconds to flush any debris from the hose. Then turn the water off.
2. Inspect the water inlet screen on the pump and remove any debris.
3. Connect the hose to the water inlet (Fig. 10 - 2) and tighten by hand. There must be a minimum of 10 feet of unrestricted hose between the pressure washer and the faucet or shut off valve.
4. Turn on the water.
5. Purge the system's pump of air by releasing the safety and squeezing the trigger of the spray gun.

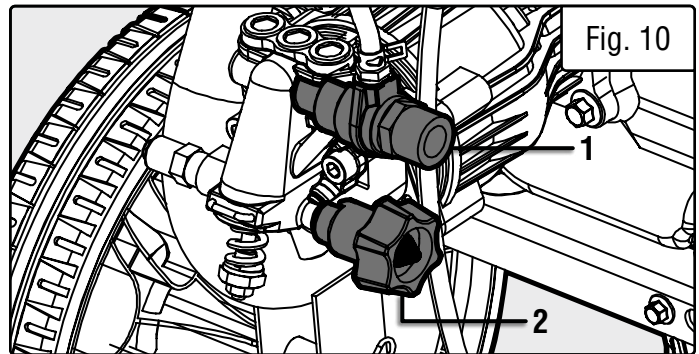

⚠ WARNING! The intake water temperature must not exceed 104°F (40°C). The water supply must not exceed 101 PSI (700 kPa).

ADJUSTING THE HANDLE & SPRAY GUN HOLDER

Adjust the handle and spray gun holder to suit your preferences, or for storing the pressure washer.

1. To adjust the handle, loosen the handle adjustment knobs (Fig. 11 - 1), reposition the handle, and tighten the knobs.
2. To adjust the gun holder, loosen the knob (Fig. 2 - 2), reposition the holder, and tighten the knob.

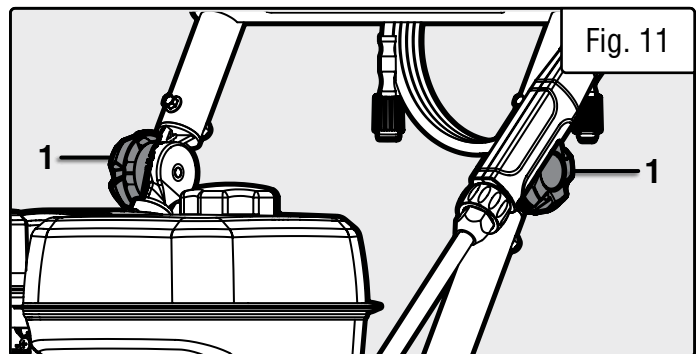

OPERATION

⚠ DANGER! CARBON MONOXIDE. Using a pressure washer indoors CAN KILL YOU IN MINUTES.

Pressure washer exhaust contains carbon monoxide (CO). This is a poison gas you cannot see or smell. If you can smell the pressure washer exhaust, you are breathing CO. Even if you cannot smell the exhaust, you may be breathing CO.

NEVER use a pressure washer inside homes, garages, crawlspaces, or other partly enclosed areas. Deadly levels of carbon monoxide can build up in these areas. Using a fan or opening windows and doors does NOT supply enough fresh air.

ONLY use a pressure washer outside and far away from windows, doors, and vents. These openings can pull in pressure washer exhaust. Even if you use a pressure washer correctly, CO may leak into the home. ALWAYS use a battery-powered or battery-backup CO alarm in the home.

If you start to feel sick, dizzy, or weak after the pressure washer has been running, move to fresh air RIGHT AWAY. See a doctor. You may have carbon monoxide poisoning.

STARTING THE PRESSURE WASHER

1. Place the pressure washer on a level surface. Turn the water on.
2. Purge the system's pump of air by releasing the safety and squeezing the trigger of the spray gun.
3. Turn fuel valve (Fig. 12 - 1) to the ON position.
4. Slide the choke lever (Fig. 12 - 2) to the "CHOKE" position.
5. Turn the engine ON/OFF switch (Fig. 13 - 1) to the "ON" position.
6. Holding the machine with one hand, pull the recoil start handle (Fig. 12 - 3) with the other hand slowly until resistance is felt, then pull rapidly. Squeeze the spray gun trigger and release the pressure after every failed attempt to start the pressure washer in order to reduce back pressure.
7. Let the engine run for several seconds before gradually sliding the choke lever (Fig. 12 - 2) to the "RUN" position as the engine warms up.

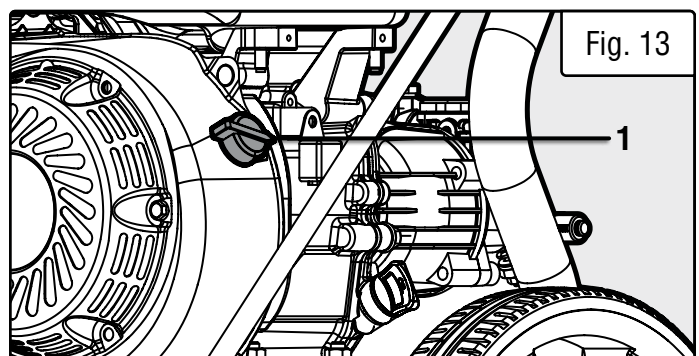
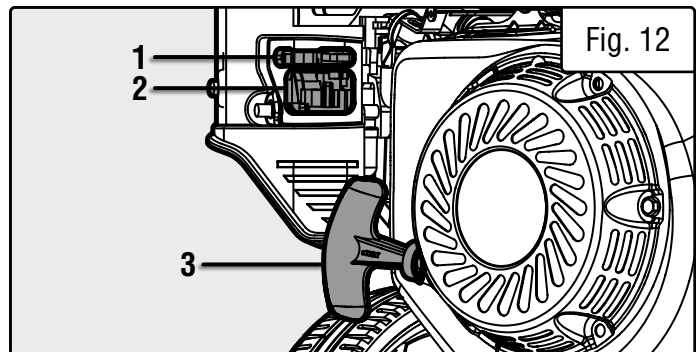

⚠ WARNING! Pulling the pull cord of the recoil starter rapidly can pull your arm towards the engine faster than you can let go, which could result in injury.

Always relieve pressure from the spray gun before pulling the starter cord, including every failed attempt to start engine.

To avoid recoil, pull the starter cord slowly until resistance is felt, then pull rapidly.

OPERATION

ENGINE BREAK-IN PROCEDURE

The procedure below should be followed when you receive your pressure washer in order to prolong the engine's service life. This procedure helps to seat the piston rings properly in the cylinder, and will reduce overall wear on the engine.

For the first 5 hours of operation, do not hold down the trigger for more than 1 minute at a time. After holding down the trigger for 1 minute, release the trigger and let the pressure washer run for at least 30 seconds. Then you may pull the trigger again. After the first 5 hours of operation, you may hold down the trigger for as long as needed.

After the first 8 hours of operation, change the oil, then change it again after the first 25 hours. Refer to the Recommended Maintenance Schedule on page 18 for the full maintenance schedule.

STOPPING THE PRESSURE WASHER

1. Turn the fuel valve to the "OFF" position. Let the engine run until the fuel is used up.
2. Turn the ON/OFF switch (Fig. 14 - 1) to the "OFF" position.

NOTE: If for some reason you need to stop the pressure washer quickly, simply flip the ON/OFF switch to "OFF". However, doing this will allow fuel to remain in the carburetor, and will lead to problems if the carburetor is not drained after use.

3. Turn off the water and squeeze the trigger handle to release all water pressure.

PRESSURE RELIEF VALVE

If pressure or temperature within the pump exceeds preset values, excess water will begin to spray out of the pressure relief valve (Fig. 15 - 1) located next to the water inlet. This is perfectly normal and acts as a corrective measure to ensure that the right amount of pressure is being used.

However, if water seems to always be leaking, it's time for your pressure relief valve to be replaced. Please contact WEN customer service at **1-847-429-9263**, M-F 8-5 Central time, for replacement parts.

USING THE SPRAY GUN

Flip the lock tab (Fig. 16 - 1) behind the trigger up or down until it clicks to apply or remove the safety. Pull back on the trigger (Fig. 16 - 2) to begin operating the pressure washer. To stop the water flow, release the trigger.

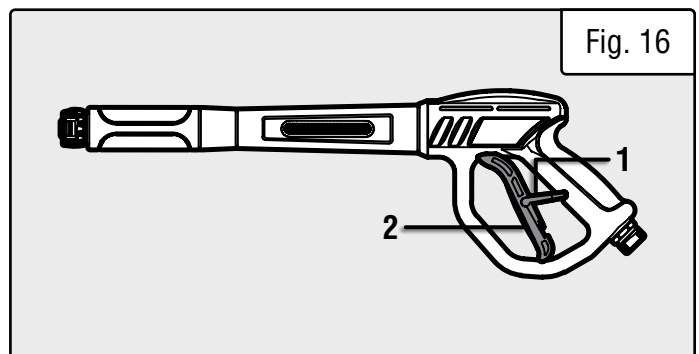
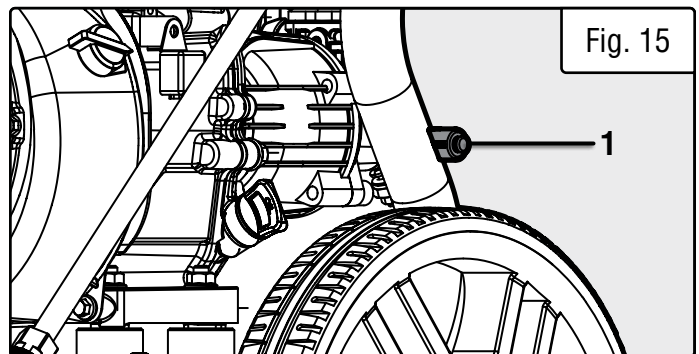
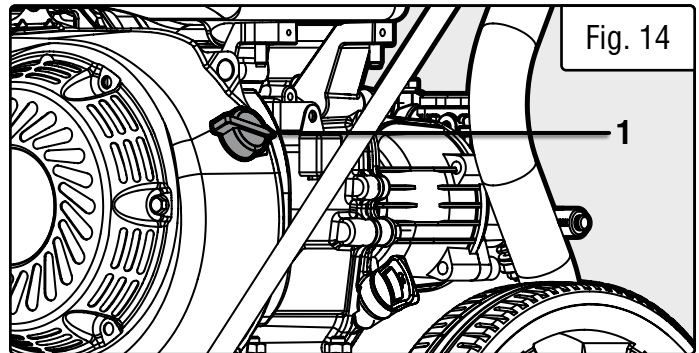

OPERATION

APPLYING DETERGENT

1. Only use the black soap nozzle for detergent.
2. Rinse surfaces with cool water before applying cleaner.
3. Prepare detergent as required. For best results follow detergent directions as supplied by detergent manufacturer. Remove cap from the detergent container and fill.
4. Spray detergent on surface. For best results use long, even, and overlapping strokes. Allow detergent to set for about 3 minutes before rinsing, but do not allow the detergent to dry on the surface or it may cause streaking or damage. Use good judgment.

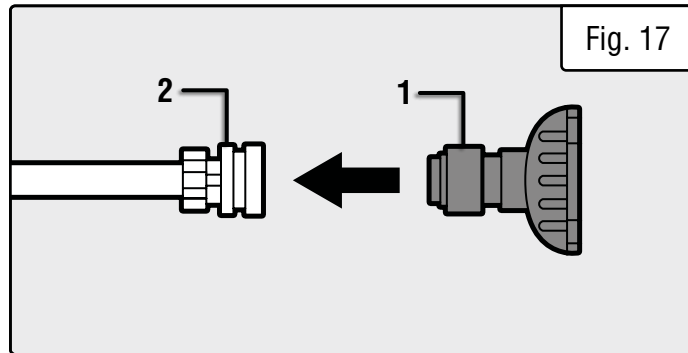

Fig. 17

5. To clean equipment after use, flush water through the spray nozzle for 1-2 min. then shut off the engine. Soak nozzle in a bucket of clean water to remove detergent. To empty out soap from the pressure washer, disconnect the hose found underneath the pressure washer and let remaining soap drain out.

USING THE SPRAY NOZZLE

1. To connect or disconnect the spray tip (Fig. 17 - 1), pull back on the quick-connect collar (Fig. 17 - 2). Insert or remove spray tip then release the collar.
2. When spray tip is connected, pull on the spray tip to make sure it is secured.
3. For general cleaning use the 40° spray tip. This option is for cement walkways.
4. For stripping, spot cleaning, blasting, and hard to reach areas use the 15° spray tip. This option is for removing paint, rust, mildew, marine growth on boats, or grease stains. This option can be used for reaching second story surfaces, or for the removal of paint, rust, oil stains, tar, gum, and other stubborn substances. Use extreme caution when using this nozzle.
5. For applying pressure washer detergent, use the black soap nozzle.

⚠ WARNING! Only use detergents or soaps that are specifically designed to be used with pressure washers. Chemicals which are caustic, such as acids or bleach, can result in serious injury, property damage, or death. NEVER aim the flow of water at a person or an animal, especially when using detergent or cleaner.

MAINTENANCE

RECOMMENDED MAINTENANCE SCHEDULE

Proper routine maintenance of the pressure washer will help prolong the life of the machine. Please perform maintenance checks and operations according to the maintenance schedule below. If there are any questions about the maintenance procedures listed in this manual, please contact customer service at **1-847-429-9263** (M-F 8-5 CST), or email techsupport@wenproducts.com.

⚠ WARNING! Never perform maintenance operations while the pressure washer is running. Before maintaining or servicing, turn OFF the pressure washer, disconnect all devices, and allow the machine to cool down.

Recommended Maintenance Schedule		Every 8 Hours or Daily	Every 25 Hours	Every 3 Months or 50 Hours	Every 6 Months or 100 Hours	Before Storage	As Necessary
Engine Oil	Check Level	X					
	Replace	X**	X**	X*			X
Air Filter	Check			X*			
	Clean			X*			
Spark Plug	Check/Clean/Regap				X		
	Change				X		X
Fuel	Check Level	X					
	Drain					X	X
Carburetor	Drain	X					X
Spark Arrestor	Check/Clean			X*			

* Clean/change more often under dusty conditions or operating under heavy load.

** Change the oil after the first 8 hours of operation, after the first 25 hours of operation, and every 50 hours after that.

PRE-OPERATION STEPS

Before starting the engine, perform the following pre-operation steps:

1. Check the level of the engine oil and the fuel tank.
2. Make sure the air filter is clean.
3. Remove any debris that has collected on the pressure washer.
4. Check high pressure hose for damage.
5. Briefly run garden hose to flush out any debris or insects.
6. Inspect the work area for hazards.
7. Clean any debris that has collected around or behind the muffler, air cleaner and controls.
8. Use a damp cloth to wipe exterior surfaces. If dirt is caked on, use a soft bristle brush.

MAINTENANCE

AFTER EACH USE

Follow these procedures after each use:

1. Shut off engine and turn off water supply. Release water pressure by pointing spray gun in a safe direction and squeezing the trigger.
2. Disconnect high pressure hose, spray gun, and nozzle. Drain water from items and use a rag to wipe down the outside of the hose and spray gun.
3. Empty the water from the pump by pulling the recoil starter 6 times.
4. Drain the carburetor (see below).
5. Store unit in a clean and dry area after it has had a chance to cool down.
6. Use of a pressure washer pump conditioner is recommended, particularly for winter storage. Follow the instructions provided by the manufacturer of the pump conditioner.

CHECKING THE OIL

Check the oil level of the pressure washer according to the Recommended Maintenance Schedule. The pressure washer should be checked before each use for proper oil level. This is a critical step for proper engine starting.

To check the oil level:

1. Make sure the pressure washer is on a level surface.
2. Clean around oil fill. Remove dipstick and wipe the dipstick with a clean rag. Insert the dipstick into the oil fill opening without screwing in. Remove the dipstick to check the oil mark. Add oil if the oil mark covers less than one half of the dipstick. (Fig. 18)

NOTE: Your pressure washer is compatible with the WEN **55201** magnetic oil dipstick, which is available for purchase at wenproducts.com.

3. Slowly add more oil and repeat step 2 until the oil mark reaches to the top of dipstick. Do not over fill the crankcase.
4. Reinstall oil dipstick.

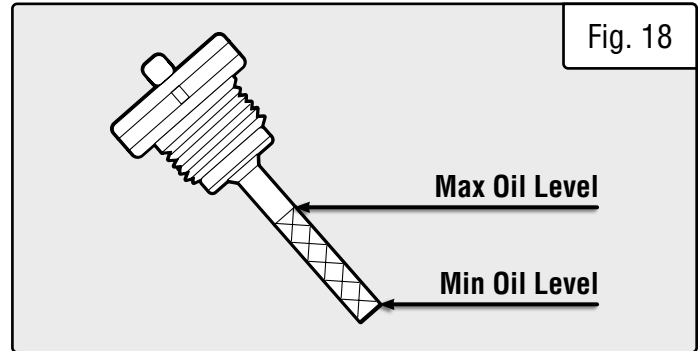

Fig. 18

CLEANING THE SPARK ARRESTOR

Clean the spark arrestor with a wire brush every 50 hours or 3 months of use. The spark arrestor is the small screen located on the muffler exhaust.

CAUTION! The muffler is very hot after use. Allow the muffler to cool down completely before cleaning the spark arrestor. It cannot be removed from the muffler.

DRAINING THE CARBURETOR

Drain the carburetor after each use to fight fuel deterioration. If you do not drain the carburetor, gasoline will degrade inside the carburetor and clog it, which will make it difficult or impossible to start next time you use it.

1. Turn the fuel valve OFF.
2. Prepare an approved gasoline-storage container. Position it underneath the carburetor drain screw (Fig. 19 - 1).
3. Use a screwdriver to loosen and remove the carburetor drain screw. Allow fuel to flow into the container.
4. Once the carburetor has drained, replace the screw.

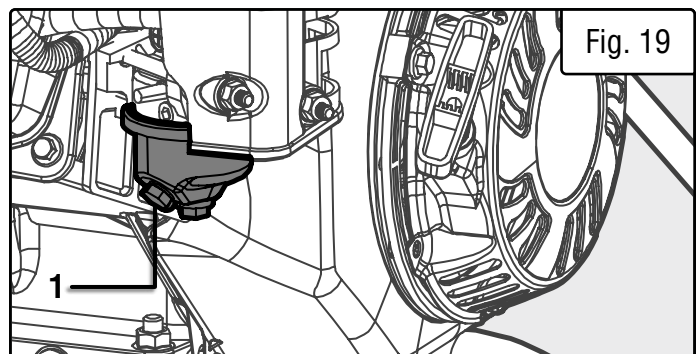

Fig. 19

MAINTENANCE

CHANGING/ADDING OIL

Change the oil according to the Recommended Maintenance Schedule on page 18. Change the oil when the engine is warm to allow for complete drainage. Change oil more often if operating under heavy load or high ambient temperatures. It is also necessary to drain the oil from the crankcase if it has become contaminated with water or dirt. The oil capacity of the pressure washer engine is 17 fl. oz. (500 mL). Add oil when the oil level is low. For proper type of oil refer to the “add oil” portion of the “Preparation” section.

NOTE: Your pressure washer is compatible with the WEN 55201 magnetic oil dipstick, which is available for purchase at wenproducts.com.

To change oil, follow the steps below:

1. Shut off the engine. Clean the area around the oil fill dipstick to keep out debris then remove the oil dipstick.
2. Place an oil pan on the ground to catch oil. Remove the oil drain bolt (Fig. 20 - 1) then tilt pressure washer back and to the side to empty out the oil from the crankcase.
3. Once oil is completely drained, return the pressure washer to a level position and install the oil drain bolt. Refill the engine with new oil as instructed earlier in this manual under Adding/Checking Oil.

AIR FILTER MAINTENANCE

Routine maintenance of the air filter helps maintain proper airflow to the carburetor. Occasionally check that the air filter is free of excessive dirt. Refer to Recommended Maintenance Schedule.

1. Loosen and remove the wing nut (Fig. 21 - 1) on top of the air filter cover, then remove the cover.
2. Remove the air filter element from the casing.
3. Check and clean the air filter element. Replace with a new one if the element is damaged. New elements can be purchased from wenproducts.com (**part no. PW224G-185**). A good element can be washed in soapy water and dried. Saturate the element with clean engine oil and squeeze off excess oil.
4. Re-install the element. Wipe off excess oil from the air filter housing. A small amount of oil in the element is normal and necessary for the engine to work properly.
5. Reinstall the air filter element, cover, and wing nut.

CAUTION! Running the engine with a dirty, damaged, or missing air filter element will cause the engine to wear out prematurely.

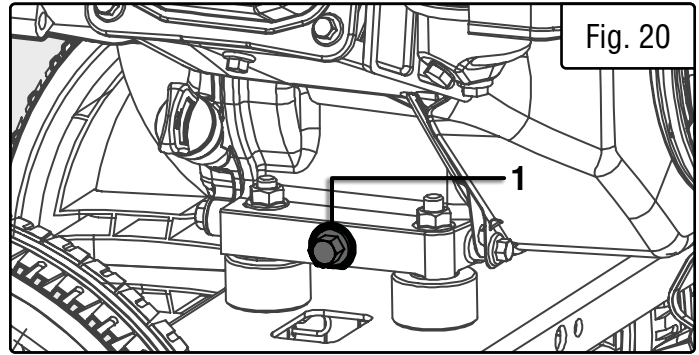

Fig. 20

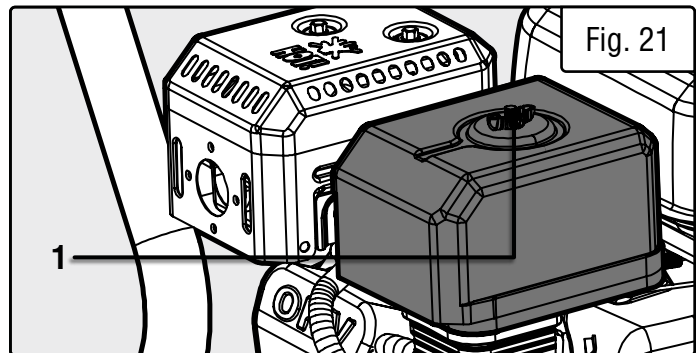

Fig. 21

MAINTENANCE

DRAINING THE FUEL TANK

Clean fuel tank each year or before storing the pressure washer for extended periods of time. To drain the fuel tank and carburetor:

1. Prepare an approved gasoline-storage container. Turn the fuel valve to the “OFF” position. Position the container so it will catch fuel draining from the carburetor drain screw.
2. Loosen the drain screw until fuel begins to flow out of the carburetor, then turn the fuel valve to the “ON” position. The gas tank will drain through the carburetor.

CAUTION! Store the emptied gasoline in a safe place. Do not store fuel for more than 3 months.

DRAINING THE SOAP

To drain the soap, unplug the hose (Fig. 22 - 1). Use a container to hold the draining soap. Once the soap is done draining, reconnect the hose.

SPARK PLUG MAINTENANCE

The spark plug is important for proper engine operation. A good spark plug should be intact, free of deposits, and properly gapped. Refer to Recommended Maintenance Schedule.

To inspect the spark plug:

1. Remove the spark plug boot (Fig. 23 - 1). Be careful not to tear insulation or wiring.
2. Unscrew the spark plug from the engine using a spark plug wrench. There is limited space for the wrench to turn. Use both rows of holes in the spark plug wrench to gain leverage to loosen the plug.
3. Visually inspect the spark plug for cracks or excessive electrode wear. Replace as necessary. Replacement spark plugs can be purchased from wenproducts.com (part no. **P54060**).
4. Measure the plug gap with a wire gauge. The gap should be **0.7 - 0.8mm (0.028 - 0.031 in.)** (Fig. 24).
5. If re-using the spark plug, use a wire brush to clean any dirt from around the spark plug base then re-gap the spark plug.
6. Screw the spark plug back into the spark plug hole using the spark plug wrench. Do not over-tighten spark plug. Recommended tightening of spark plug is $\frac{1}{2}$ to $\frac{3}{4}$ of a turn after the spark plug gasket contacts the spark plug hole, or 15 ft-lb. Reinstall the spark plug boot.

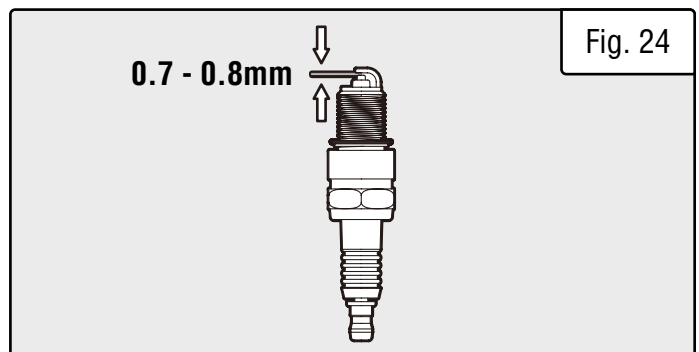
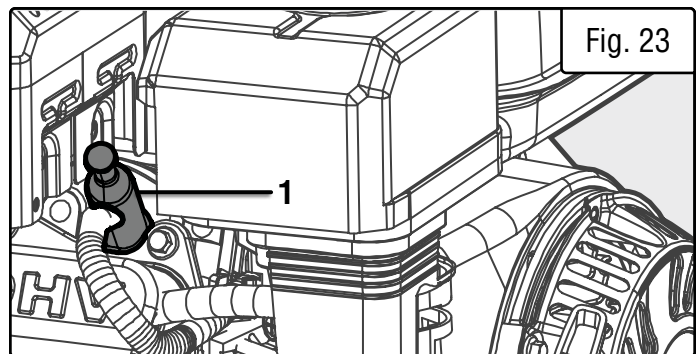
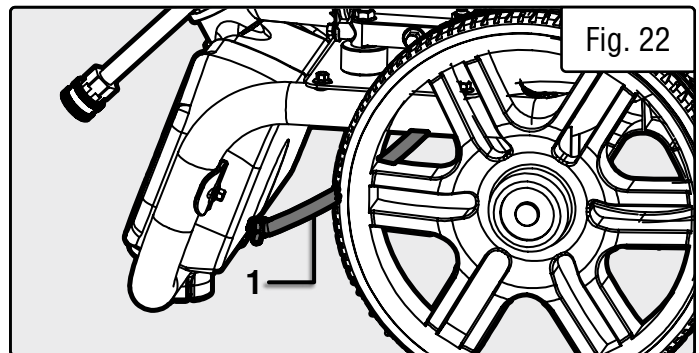

MAINTENANCE

CHECKING DETERGENT SIPHONING TUBE

1. Check the detergent siphoning tube for clogs, leaks, or tears.
2. Make sure the tube fits tightly on the pump fitting.
3. Replace the siphoning tube if it is damaged.

HIGH PRESSURE HOSE

1. Inspect the hose for cuts, bulges, or leaks which can develop from kinking or wear. If damage is found, immediately replace the hose.
2. Inspect the couplings for damage. Immediately replace the hose if damage is found.

WARNING! Never repair a high pressure hose or use the unit if the hose is damaged. If the hose is damaged, replace it. Contact WEN customer service for assistance.

SPRAY GUN

1. Make sure the spray gun is connected securely.
2. Inspect the spray gun safety and make sure the spray gun trigger springs back upon release.

SPRAY NOZZLE

If a pulsing sensation is felt while squeezing the trigger, the spray nozzle may be dirty or clogged, and should be cleaned immediately.

To clean the nozzle:

1. Shut off the engine and turn off the water.
2. Remove the nozzle from the spray wand, making sure that the nozzle is pointing away from you and in a safe direction.
3. Use the nozzle cleaner (Fig. 25) to dislodge any foreign materials which are clogging or restricting the spray tip. Flush debris out of the nozzle by back flushing with a garden hose for 30-60 seconds.
4. Reconnect the nozzle to the spray wand.
5. Turn the water supply back on and start engine.

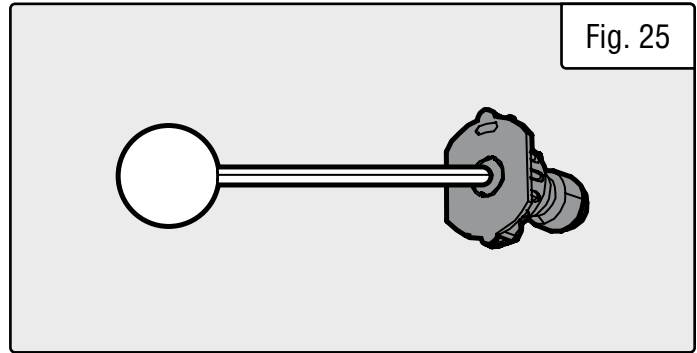

TRANSPORTATION & STORAGE

CAUTION! Never place any type of storage cover on the pressure washer while it is still hot.

If the pressure washer is being stored for short periods of time (30 to 60 days), add stabilized fuel to the fuel tank until full.

NOTE: Filling the tank reduces the amount of air in the tank and helps reduce deterioration of fuel. Run the engine for 2 – 3 minutes allowing stabilized fuel mixture to circulate through the carburetor.

STORING THE PRESSURE WASHER FOR EXTENDED PERIODS

1. Drain the fuel tank (see “Draining the Fuel Tank” in the “Maintenance” section).
2. Change oil.
3. Do not obstruct any ventilation openings.
4. Keep the pressure washer in a cool dry area. Adjust the handle and/or spray gun holder if desired (see p. 14).

WINTER STORAGE (BELOW 40°F)

1. Follow instructions to store washer for extended periods.
2. Drain all water from hose, gun, etc.
3. We recommend using a pump conditioner for winter storage. Follow the instructions provided by the conditioner manufacturer.

TRANSPORTING THE PRESSURE WASHER

1. Tighten fuel cap. Drain the fuel tank if possible.
2. Always keep the pressure washer upright. Do not lay it down sideways.

TROUBLESHOOTING GUIDE

⚠ WARNING! Stop using the pressure washer immediately if any of the following problems occur or risk serious personal injury. If you have any questions, please contact customer service at **1-847-429-9263** (M-F 8-5 CST), or email techsupport@wenproducts.com.

PROBLEM	CAUSE	SOLUTION
Engine will not start.	1. The engine switch is set to "OFF".	1. Set the engine switch to "ON".
	2. The fuel valve is turned to "OFF".	2. Turn the fuel valve to "ON".
	3. The choke is open.	3. Close the choke.
	4. The engine is out of fuel.	4. Add gasoline.
	5. The engine is filled with contaminated or old gasoline.	5. Change the gasoline in the gas tank.
	6. The spark plug is dirty.	6. Clean the spark plug.
	7. The spark plug is broken.	7. Replace the spark plug.
	8. The pressure washer is not on level surface.	8. Move the pressure washer to a level surface to prevent low oil shutdown from triggering.
	9. Oil is low.	9. Add or replace oil.
Water pressure is weak.	1. The water supply is restricted.	1. Inspect the garden hose for leaks. Make sure you are using a large enough hose (min. 3/4" diameter).
	2. The water is not turned on to full power.	2. Open the water source all the way.
	3. Not using the high pressure nozzle.	3. Change the nozzle.
Detergent and spray do not mix.	1. The detergent hose is not submerged or has disconnected.	1. Make sure the hose is connected and submerged in the detergent.
	2. The black soap nozzle needed.	2. Use the black soap nozzle.
Pump fails to produce pressure or pressure is inconsistent.	1. The water supply is restricted	1. Inspect the garden hose for leaks. Make sure you are using a large enough hose (min. 3/4" diameter).
	2. The water not turned on full power.	2. Open the water source all the way.
	3. The nozzle is clogged.	3. Clean the nozzle.
	4. The spray gun leaks.	4. Check the spray gun connection or replace the spray gun.
	5. Air in the line.	5. Squeeze the trigger handle to remove air from the line.
	6. The inlet hose screen is clogged.	6. Clean the inlet.
	7. The water supply is over 100° F.	7. Use cool water supply.
	8. The pump is faulty.	8. Contact customer service at 1-847-429-9263 for assistance.

EXPLODED VIEW & PARTS LIST

PRESSURE WASHER

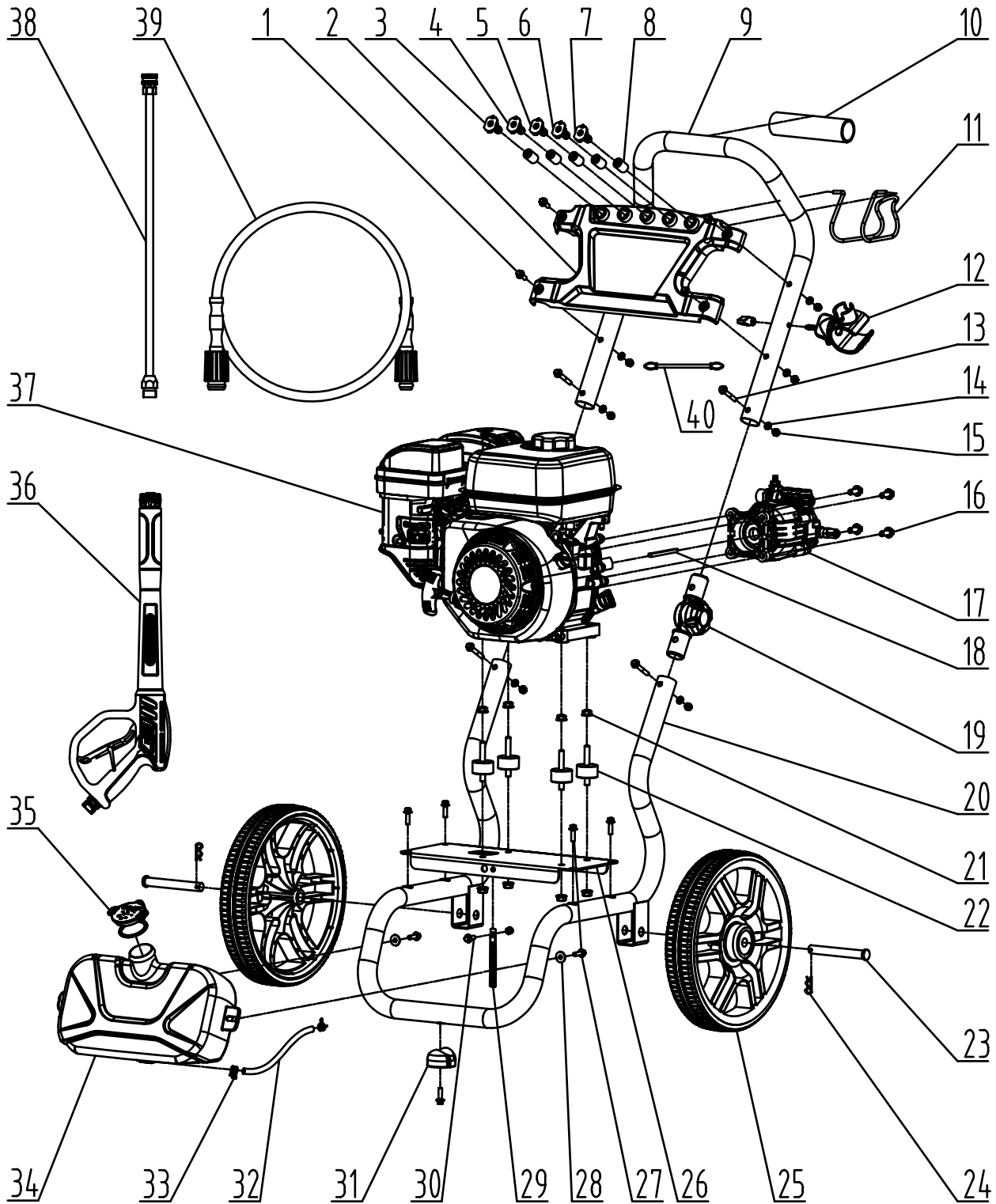

EXPLODED VIEW & PARTS LIST

PRESSURE WASHER

No.	Part No.	Description	Qty.	No.	Part No.	Description	Qty.
1	PW224G-001	Flanged Hex Bolt, M6x50	4	22	PW224G-022	Engine Mount	4
2	PW224G-002	Panel	1	23	PW224G-023	Wheel Axle Pin	2
3	PW224G-003	Red Nozzle (0°)	1	24	PW224G-024	R-pin	2
4	PW224G-004	Yellow Nozzle (15°)	1	25	PW224G-025	Wheel	2
5	PW224G-005	Black Nozzle (Soap)	1	26	PW224G-026	Engine Baseplate	1
6	PW224G-006	Green Nozzle (25°)	1	27	PW224G-027	Flanged Hex Bolt, M6x20	7
7	PW224G-007	White Nozzle (40°)	1	28	PW224G-028	Flat Washer, 6mm	2
8	PW224G-008	Nozzle Holder Insert	5	29	PW224G-029	Hose Positioning Clip	1
9	PW224G-009	Upper Handle	1	30	PW224G-030	Flanged Hex Bolt, M6x10	1
10	PW224G-010	Handle Sleeve	1	31	PW224G-031	Foot	1
11	PW224G-011	High Pressure Hose Hook	1	32	PW224G-032	Soap Tank Hose, 75cm	1
12	PW224G-012	Gun Holder	1	33	PW224G-033	Hose Clamp	2
13	PW224G-013	Flanged Hex Bolt, M6x40	4	34	PW224G-034	Soap Tank	1
14	PW224G-014	Flat Washer, 6mm	8	35	PW224G-035	Soap Tank Cap	1
15	PW224G-015	Lock Nut, M6	9	36	PW224G-036	Spray Gun	1
16	PW224G-016	Flanged Hex Bolt, M8x20	4	37	PW224G-037ASM	Engine Assembly	1
17	PW224G-017	Pump	1	38	PW224G-038	Spray Wand	1
18	PW224G-018	Shaft Key	1	39	PW224G-039	High Pressure Hose	1
19	PW224G-019	Rotating Arm	2	40	PW224G-040	High Pressure Hose Cord	1
20	PW224G-020	Main Frame	1				
21	PW224G-021	Flanged Nut, M8	8				

NOTE: Not all parts may be available for purchase. Parts and accessories that wear down over the course of normal use are not covered under the warranty.

EXPLODED VIEW & PARTS LIST

ENGINE

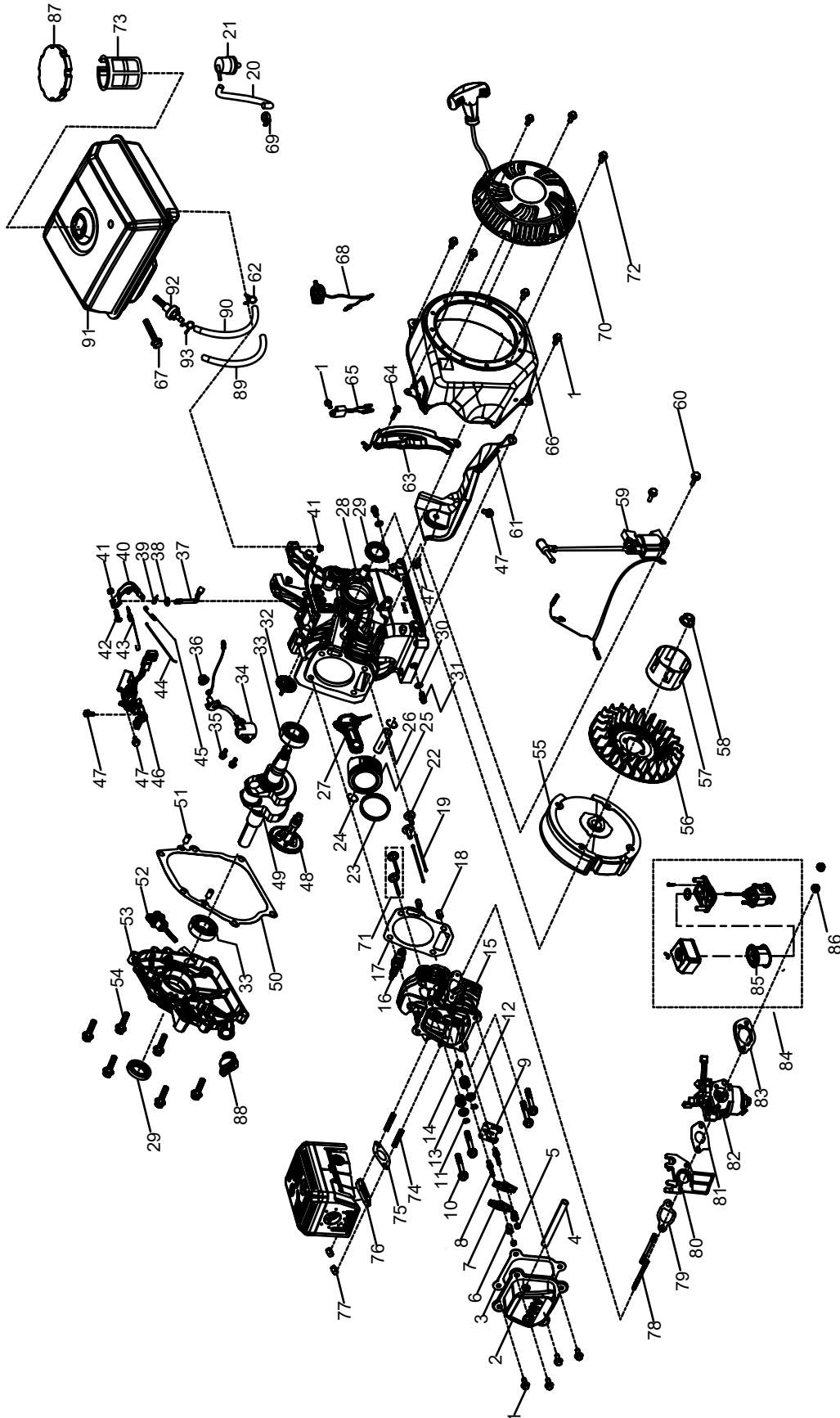

EXPLODED VIEW & PARTS LIST

ENGINE

No.	Part No.	Description	Qty.	No.	Part No.	Description	Qty.
1	P54040	Bolt, M6x12	9	33	PW224G-133	Deep Groove Ball Bearing	2
2	PW224G-102	Cylinder Head Cover Subassembly	1	34	P54020	Engine Oil Sensor	1
3	PW224G-103	Cylinder Head Cover Gasket	1	35	P54024	Bolt, M6x14	2
4	PW224G-104	Breather Tube	1	36	P54003	Flanged Hex Nut, M10	1
5	PW224G-105	Valve Lock Nut, M6	2	37	PW224G-137	Governor Arm	1
6	PW224G-106	Valve Adjusting Nut, M6	2	38	P54016	Flat Washer	1
7	PW224G-107	Valve Rocker	2	39	P54018	Cotter Pin	1
8	PW224G-108	Rocker Bolt, M6x31	2	40	P54624	Governor Bracket Subassembly	1
9	PW224G-109	Valve Lifter Stopper Plate Subassembly	1	41	P54176	Flanged Hex Nut, M6	3
10	P54062	Cylinder Head Bolt, M8x60	4	42	P54622	Governor Support Bolt, M6x21	1
11	P54160	Valve Lock Clamp	4	43	PW224G-143	Governor Spring	1
12	P54158	Valve Spring Seat	2	44	PW224G-144	Governor Rod	1
13	P54154	Valve Spring	2	45	P54618	Throttle Return Spring	1
14	P54161	Seal Guide	1	46	PW224G-146	Throttle Control Assembly	1
15	PW224G-115	Cylinder Head Subassembly	1	47	56475-1109	Bolt, M6x10	4
16	P54060	Spark Plug, Torch F6TC (NGK BP6ES)	1	48	PW224G-148	Camshaft	1
17	PW224G-117	Cylinder Head Gasket	1	49	PW224G-149	Crankshaft	1
18	P54048	Position Pin	2	50	P54080	Crankcase Gasket	1
19	PW224G-119	Valve Lifter	2	51	P54082	Position Pin	2
20	PW224G-120	Evaporative Hose	1	52	P54086	Oil Dipstick Assembly	2
21	PW224G-121	One-way Valve	1	53	PW224G-153	Crankcase Cover	1
22	P54142	Valve Tappet	2	54	P54092	Bolt, M8x32	6
23	PW224G-123	Piston Ring Set	1	55	PW224G-155	Flywheel Subassembly	1
24	PW224G-124	Piston Pin Clip	2	56	GN5000-1103	Impeller	1
25	PW224G-125	Piston	1	57	PW224G-157	Starter Pulley	1
26	PW224G-126	Piston Pin	1	58	P54630	Flywheel Nut, M14	1
27	PW224G-127	Connecting Rod	1	59	P54638	Ignition Coil	1
28	PW224G-128	Crankcase Subassembly	1	60	56475-1105	Bolt, M6x25	2
29	P54008	Oil Seal	2	61	PW224G-161	Cylinder Shroud	1
30	P54002	Flat Washer	2	62	PW224G-162	Hose Clamp	1
31	P54000	Drain Plug Bolt, M10x15	2	63	PW224G-163	Lower Shroud	1
32	PW224G-132	Gear Assembly, Governor	1	64	PW224G-164	Bolt, M6x20	1
				65	PW224G-165	Oil Sensor	1
				66	PW224G-166	Recoil Starter Housing	1

EXPLODED VIEW & PARTS LIST

ENGINE

No.	Part No.	Description	Qty.	No.	Part No.	Description	Qty.
67	PW224G-167	Bolt, M6x32	1	81	P54166	Carburetor Gasket	1
68	PW224G-168	Engine Switch	1	82	PW224G-182	Carburetor	1
69	PW224G-169	Hose Clamp	1	83	PW224G-183	Air Filter Gasket	1
70	PW224G-170	Recoil Starter	1	84	PW224G-184	Air Filter Assembly	1
71	PW224G-171	Valve Set	1	85	PW224G-185	Air Filter Element	1
72	PW224G-172	Bolt, M6x8	3	86	P54179	Flanged Hex Nut, M6	2
73	PW224G-173	Fuel Filter	1	87	PW224G-187	Fuel Tank Cap	1
74	P54058	Stud Bolt, M8x34	2	88	PW224G-188	Engine Oil Plug	1
75	PW224G-175	Muffler Gasket	1	89	PW224G-189	Rubber Sleeve	1
76	PW224G-176	Muffler and Spark Arrestor Assembly	1	90	PW224G-190	Fuel Tube	1
77	PW224G-177	Hex Nut, M8	2	91	PW224G-191	Fuel Tank	1
78	PW224G-178	Stud Bolt, M6x113	2	92	PW224G-192	Fuel Tank Outlet	1
79	PW224G-179	Carburetor Insulator Gasket	1	93	PW224G-193	Hose Clamp	1
80	PW224G-180	Carburetor Insulator	1	N.P.	PW224G-HA36	High-Altitude Kit, 3000 - 6000 ft	1
				N.P.	PW224G-HA68	High-Altitude Kit, 6000 - 8000 ft	1

NOTE: Not all parts may be available for purchase. Parts and accessories that wear down over the course of normal use are not covered under the warranty.

WARRANTY STATEMENT

WEN Products is committed to building tools that are dependable for years. Our warranties are consistent with this commitment and our dedication to quality.

LIMITED WARRANTY OF WEN PRODUCTS FOR HOME USE

GREAT LAKES TECHNOLOGIES, LLC (“Seller”) warrants to the original purchaser only, that this WEN consumer product will be free from defects in material or workmanship during personal use for a period of three (3) years from date of purchase or 500 hours of use; whichever comes first. Ninety days for all WEN products if the tool is used for professional or commercial use. Purchaser has 30 days from the date of purchase to report missing or damaged parts. Parts and labor are covered for one (1) year under this limited warranty; parts only are covered for three (3) years under this limited warranty.

SELLER’S SOLE OBLIGATION AND YOUR EXCLUSIVE REMEDY under this Limited Warranty and, to the extent permitted by law, any warranty or condition implied by law, shall be the replacement of parts, without charge, which are defective in material or workmanship and which have not been subjected to misuse, alteration, careless handling, misrepair, abuse, neglect, normal wear and tear, improper maintenance, improper storage, incorrect lubricants / fuels, or other conditions adversely affecting the Product or the component of the Product, whether by accident or intentionally, by persons other than Seller. To make a claim under this Limited Warranty, you must make sure to keep a copy of your proof of purchase that clearly defines the Date of Purchase (month and year) and the Place of Purchase. Place of Purchase must be a direct vendor of Great Lakes Technologies, LLC. Purchasing through third party vendors, including but not limited to garage sales, pawn shops, resale shops, or any other secondhand merchant, voids the warranty included with this product. Contact techsupport@wenproducts.com or 1-847-429-9263 with the following information to make arrangements: your shipping address, phone number, serial number, required part numbers, and proof of purchase. Damaged or defective parts and products may need to be sent to WEN before the replacements can be shipped out.

Upon the confirmation of a WEN representative, your product may qualify for repairs and service work. When returning a product for warranty service, the shipping charges must be prepaid by the purchaser. The product must be shipped in its original container (or an equivalent), properly packed to withstand the hazards of shipment. The product must be fully insured with a copy of the proof of purchase enclosed. There must also be a description of the problem in order to help our repairs department diagnose and fix the issue. Repairs will be made and the product will be returned and shipped back to the purchaser at no charge for addresses within the contiguous United States.

THIS LIMITED WARRANTY DOES NOT APPLY TO ITEMS THAT WEAR OUT FROM REGULAR USAGE OVER TIME, INCLUDING FILTERS, SPARK PLUGS, VOLTAGE REGULATORS, BRUSHES, GASKETS, O-RINGS, WHEEL KITS, BATTERIES, RECOIL STARTERS, HIGH PRESSURE HOSES, SPRAY GUNS, ETC. ANY IMPLIED WARRANTIES SHALL BE LIMITED IN DURATION TO THREE (3) YEARS FROM DATE OF PURCHASE. SOME STATES IN THE U.S. AND SOME CANADIAN PROVINCES DO NOT ALLOW LIMITATIONS ON HOW LONG AN IMPLIED WARRANTY LASTS, SO THE ABOVE LIMITATION MAY NOT APPLY TO YOU.

IN NO EVENT SHALL SELLER BE LIABLE FOR ANY INCIDENTAL OR CONSEQUENTIAL DAMAGES (INCLUDING BUT NOT LIMITED TO LIABILITY FOR LOSS OF PROFITS) ARISING FROM THE SALE OR USE OF THIS PRODUCT. SOME STATES IN THE U.S. AND SOME CANADIAN PROVINCES DO NOT ALLOW THE EXCLUSION OR LIMITATION OF INCIDENTAL OR CONSEQUENTIAL DAMAGES, SO THE ABOVE LIMITATION OR EXCLUSION MAY NOT APPLY TO YOU.

THIS LIMITED WARRANTY GIVES YOU SPECIFIC LEGAL RIGHTS, AND YOU MAY ALSO HAVE OTHER RIGHTS WHICH VARY FROM STATE TO STATE IN THE U.S., PROVINCE TO PROVINCE IN CANADA AND FROM COUNTRY TO COUNTRY.

THIS LIMITED WARRANTY APPLIES ONLY TO ITEMS SOLD WITHIN THE UNITED STATES OF AMERICA, CANADA AND THE COMMONWEALTH OF PUERTO RICO. FOR WARRANTY COVERAGE WITHIN OTHER COUNTRIES, CONTACT THE WEN CUSTOMER SUPPORT LINE. FOR WARRANTY PARTS OR PRODUCTS REPAIRED UNDER WARRANTY SHIPPING TO ADDRESSES OUTSIDE OF THE CONTIGUOUS UNITED STATES, ADDITIONAL SHIPPING CHARGES MAY APPLY.

**THANKS FOR
REMEMBERING**

