

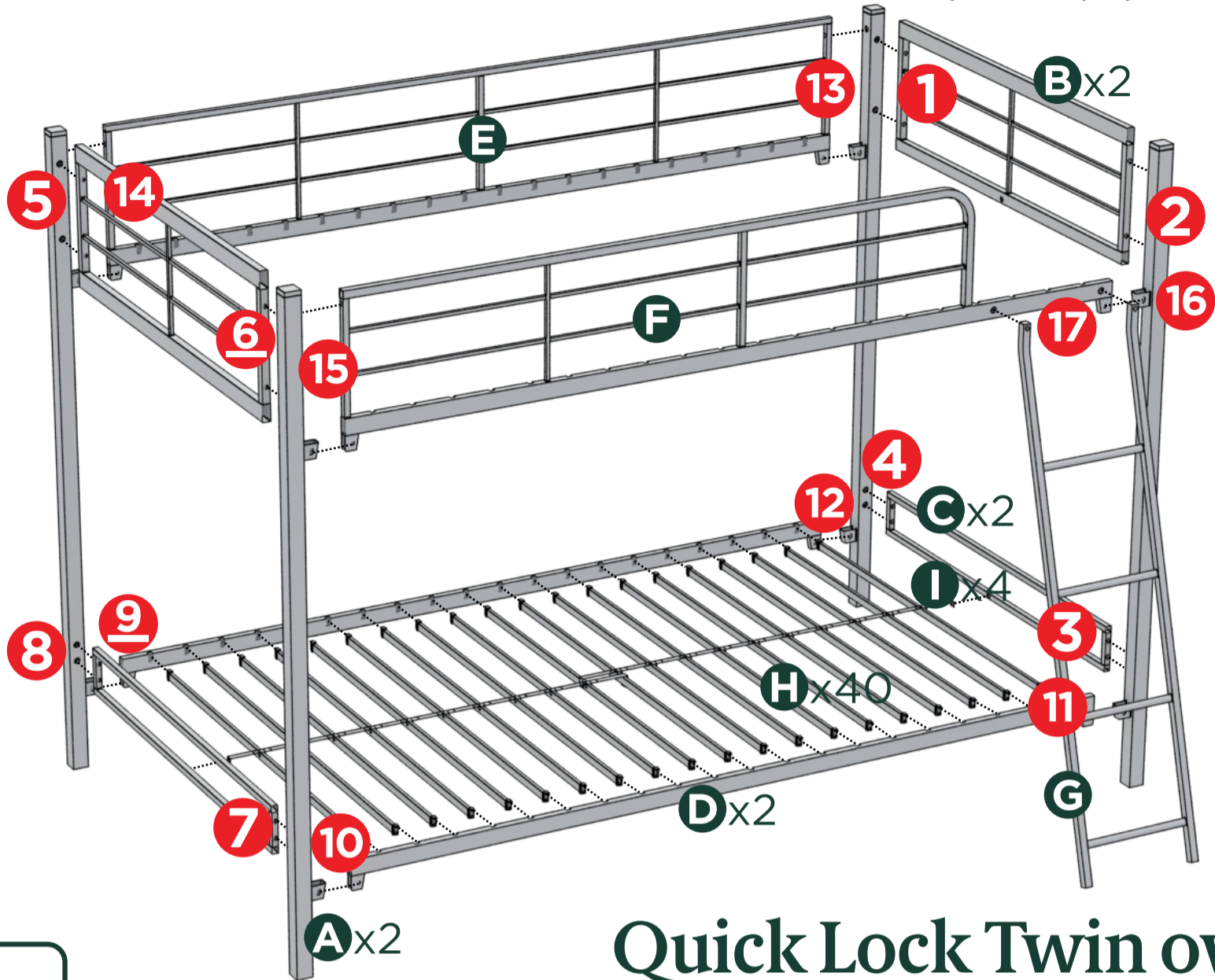

Numbering System
Easy assembly by following 1,2,3...











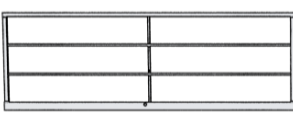

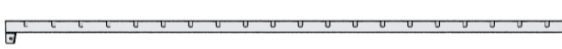
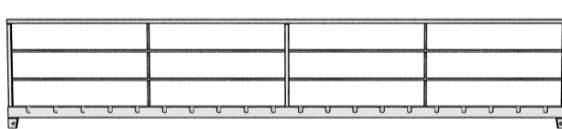
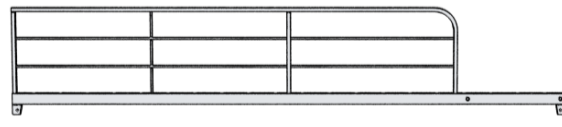
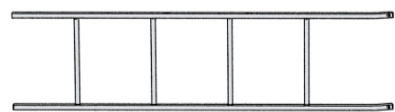
Complimentary rubber mallet.



Quick Lock Twin over Twin Metal Bunk Bed

Components

-  **A** x 2set
-  **B** x 2pcs
-  **C** x 2pcs
-  **D** x 2pcs
-  **E** x 1pc
-  **F** x 1pc
-  **G** x 1pc
-  **H** x 40pcs
-  **I** x 4pcs
-  **L** x 21 pcs
-  **M** x 5 pcs
-  **S** x 4 pcs (Quick Lock secure wrench)
-  x 1 pc
-  x 1 pc

Return Policy

ZINUS believes you will absolutely love your new addition to your home, but if for some reason you want to return the product, please contact us directly before you decide to return your product to the retailer. Our Customer Service organization can answer most concerns and can assist you with any questions you may have about your new product.

Please contact us first by emailing customerservice@zinusinc.com or by submitting a request at <https://support.zinus.com>

The item must be returned in good condition, in original box, with all original proof of purchase, parts and accessories, within the time frame specified by the retailer it was purchased from.

Please visit Zinus.com for warranty information on your new product.

 175lbs / 80 kgs for upper bed
175lbs / 80 kgs for lower bed

Easy as 1 2 3

Assembly Instruction

Numbers must Match for Secure Assembly

1 2 3 ... 17

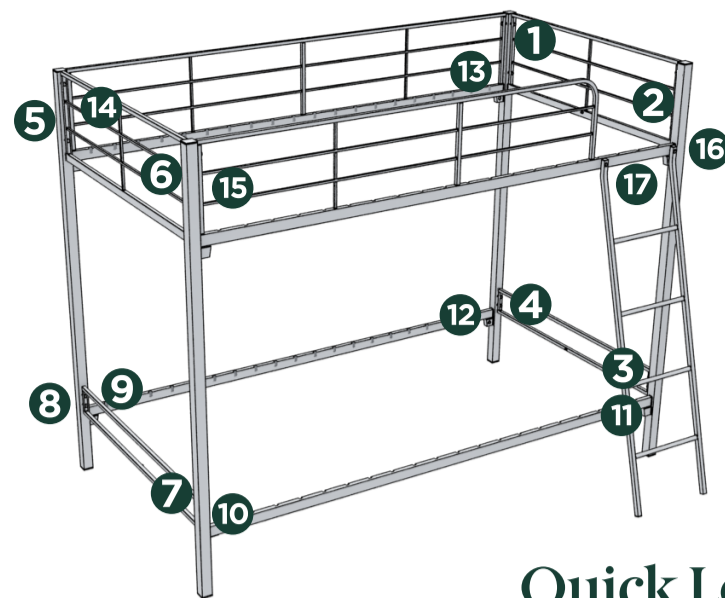

Quick Lock
Twin over Twin Metal Bunk Bed

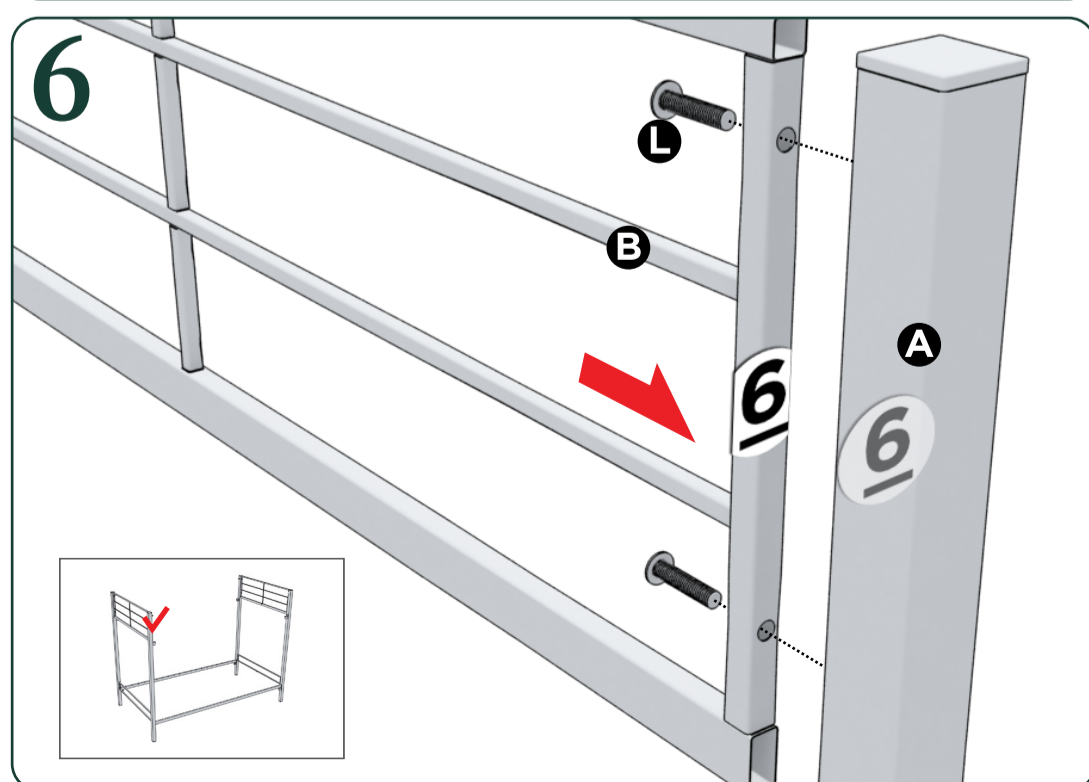
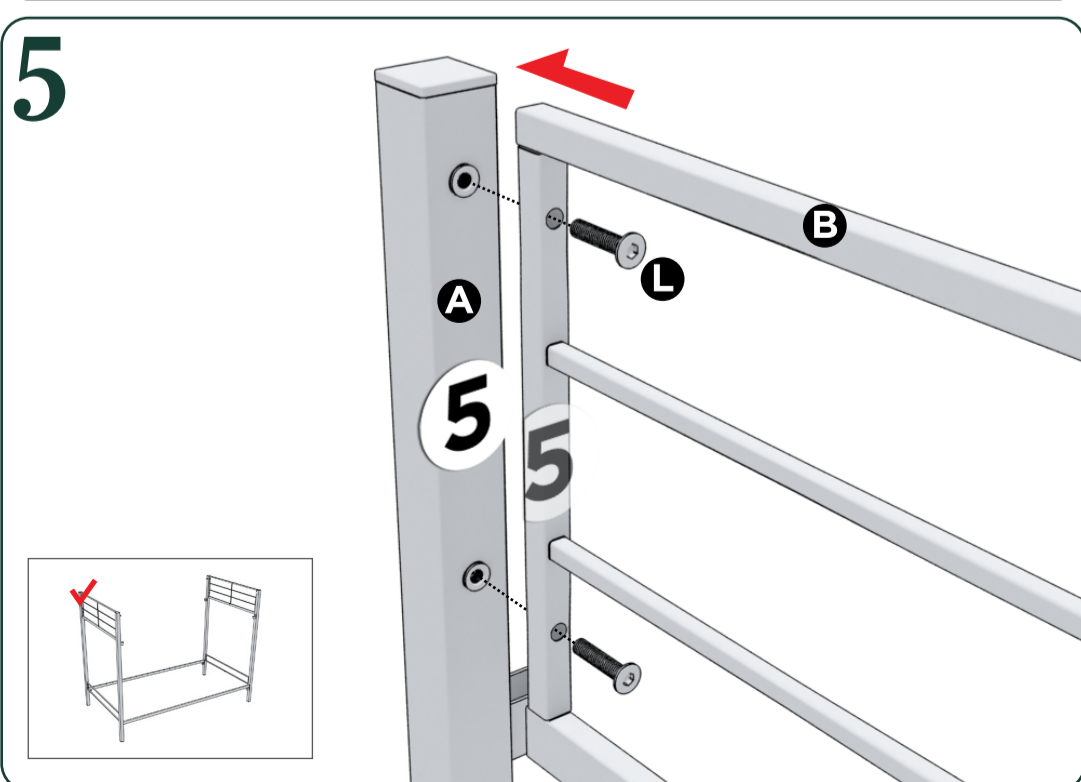
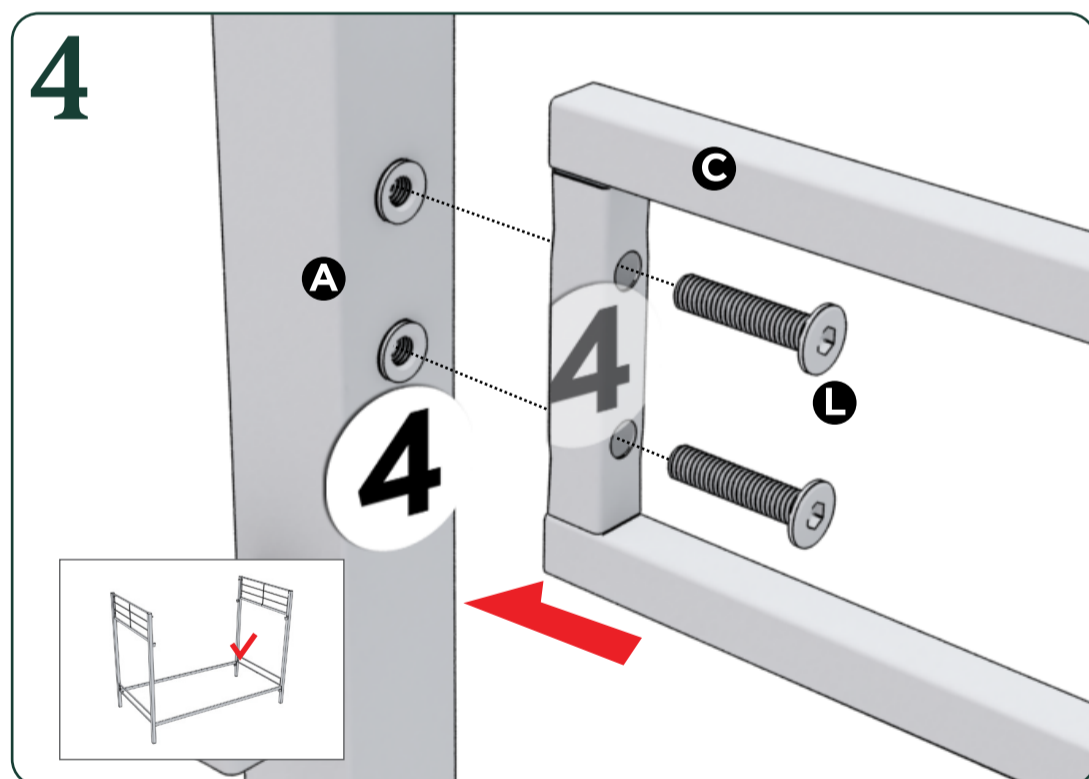
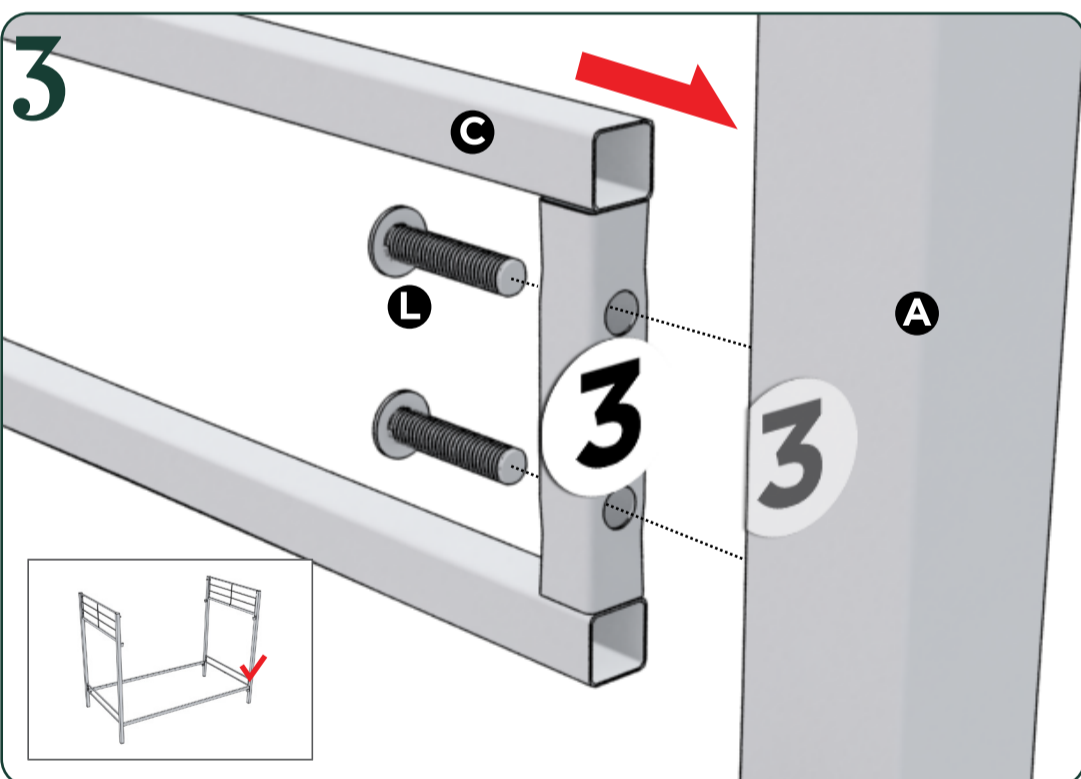
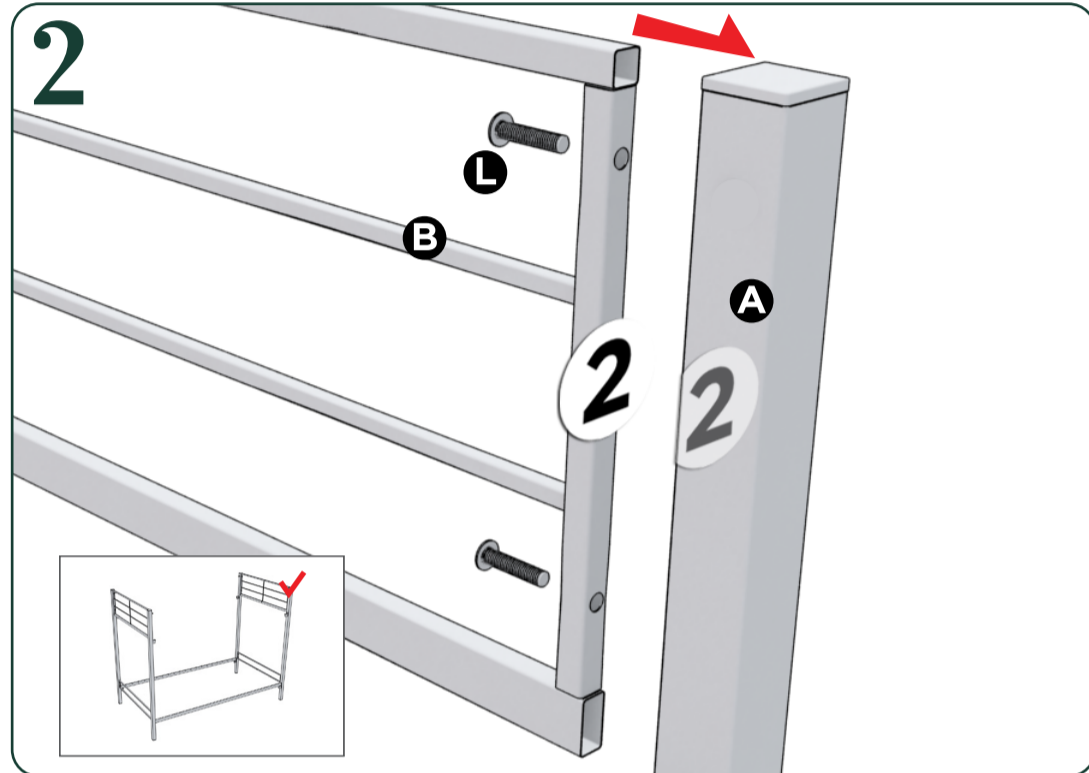
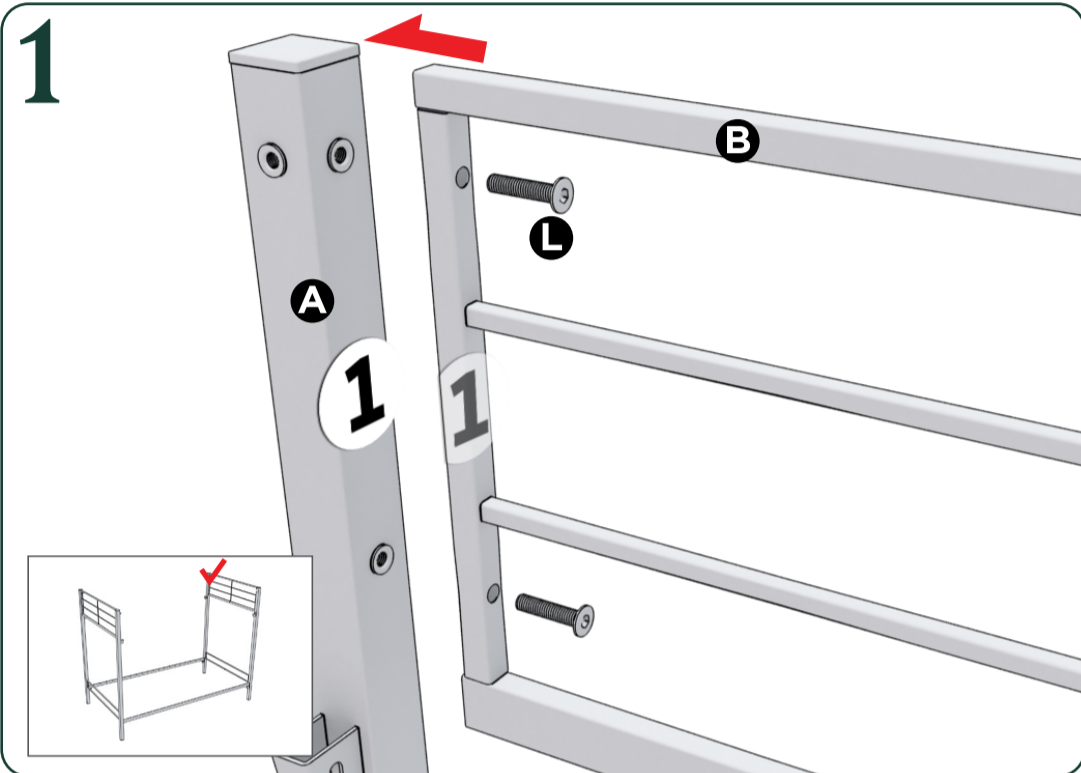

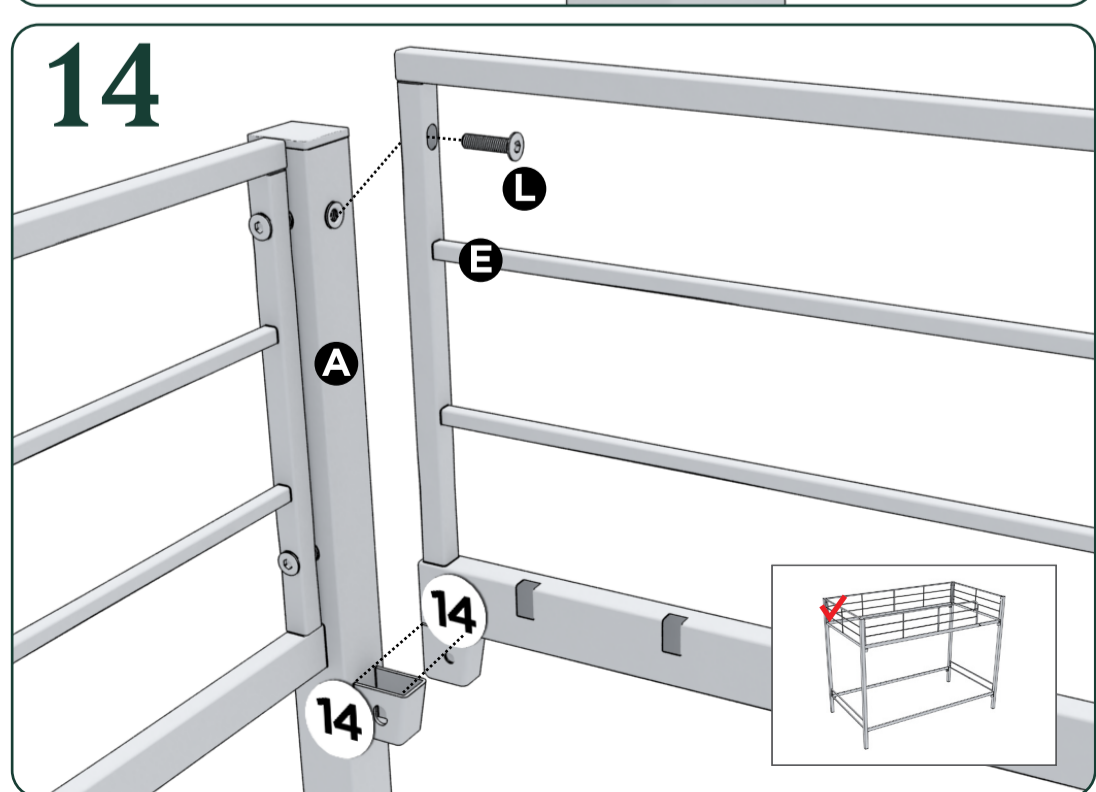
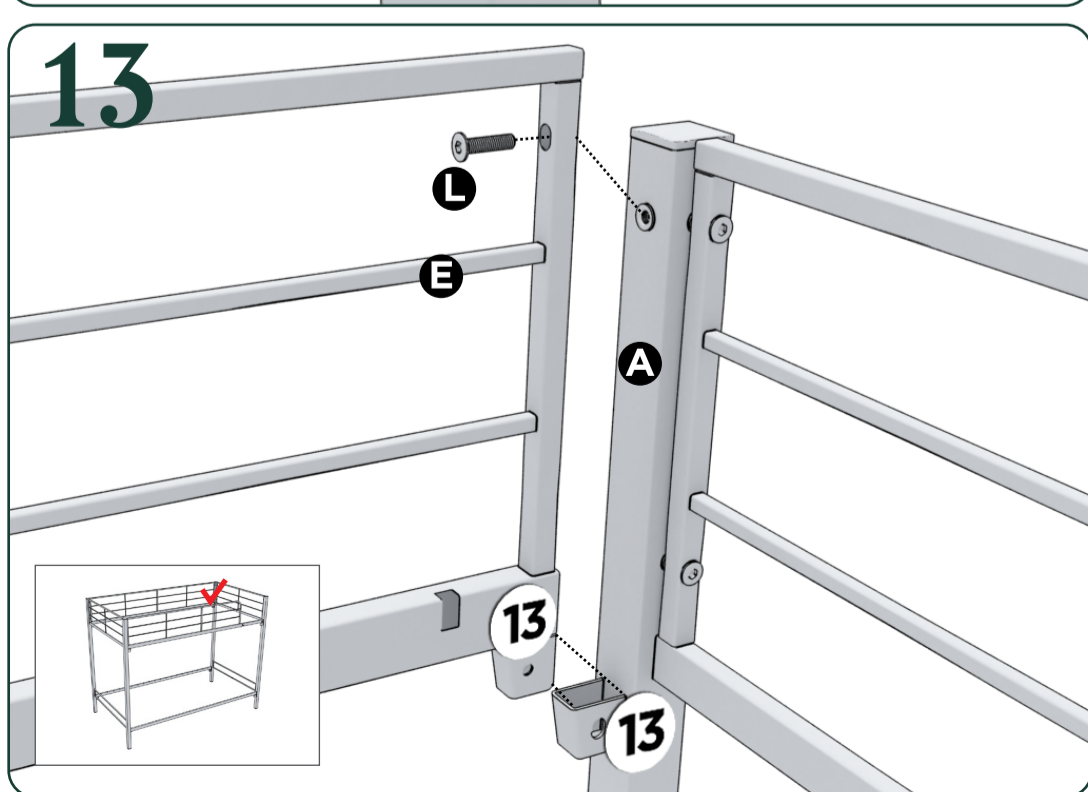
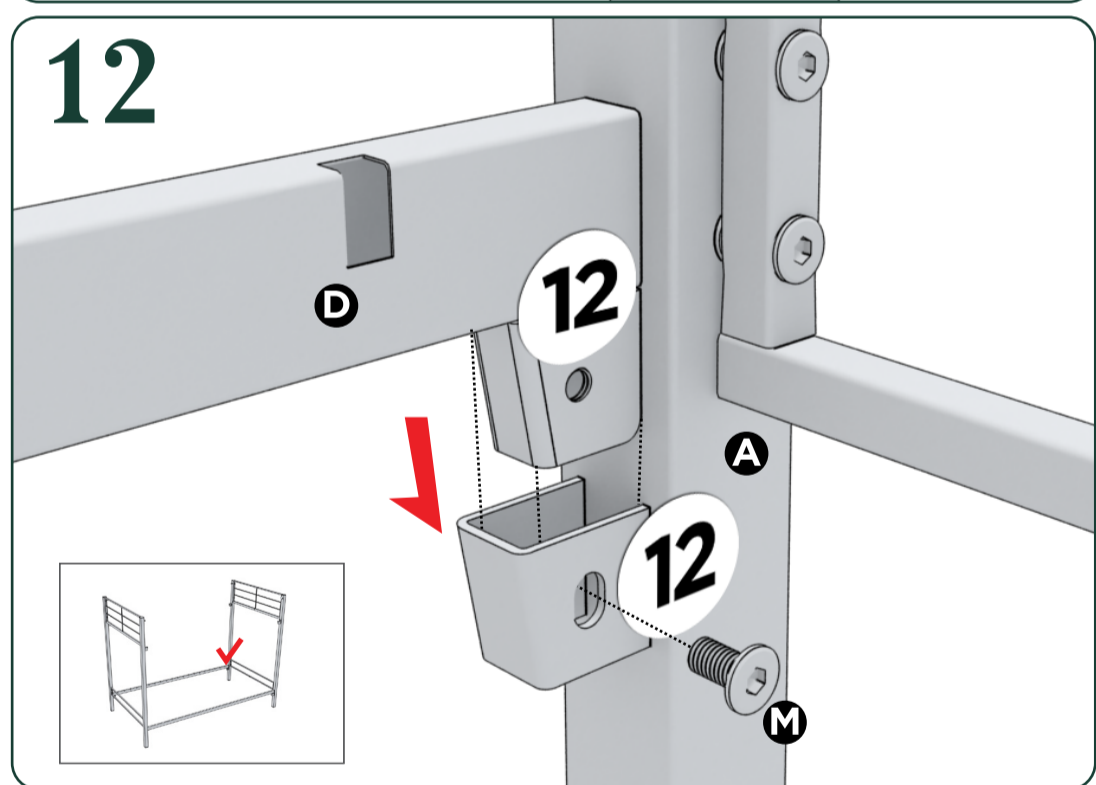
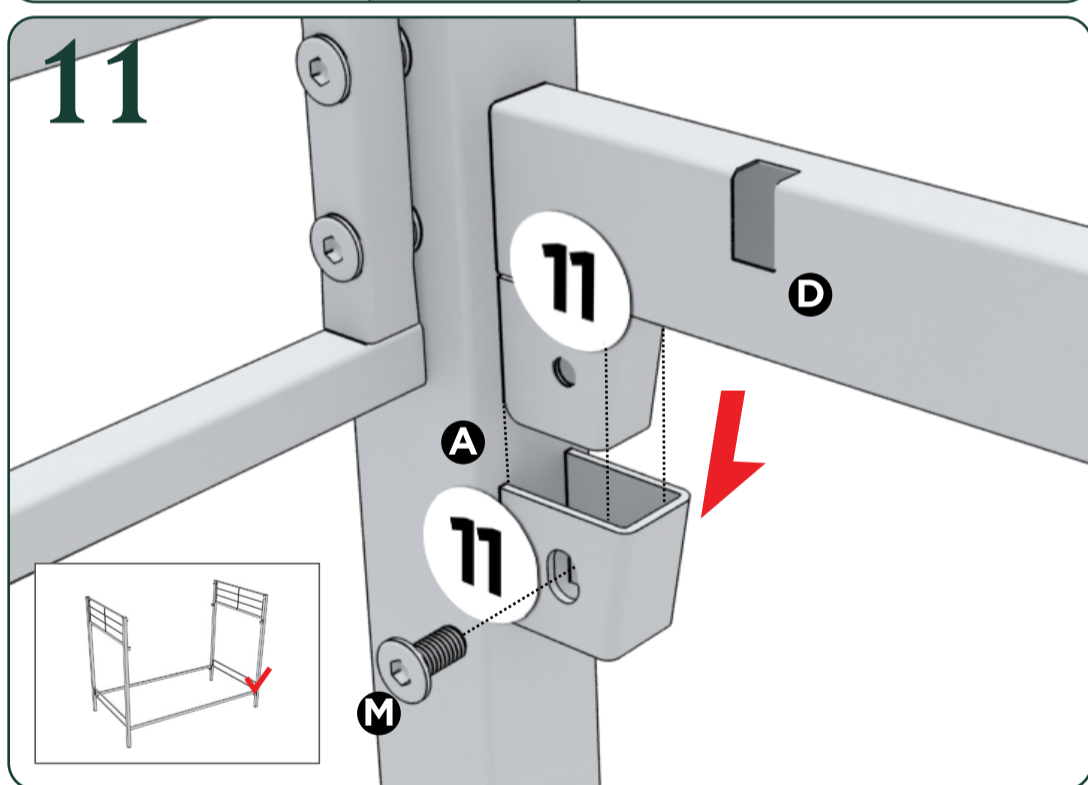
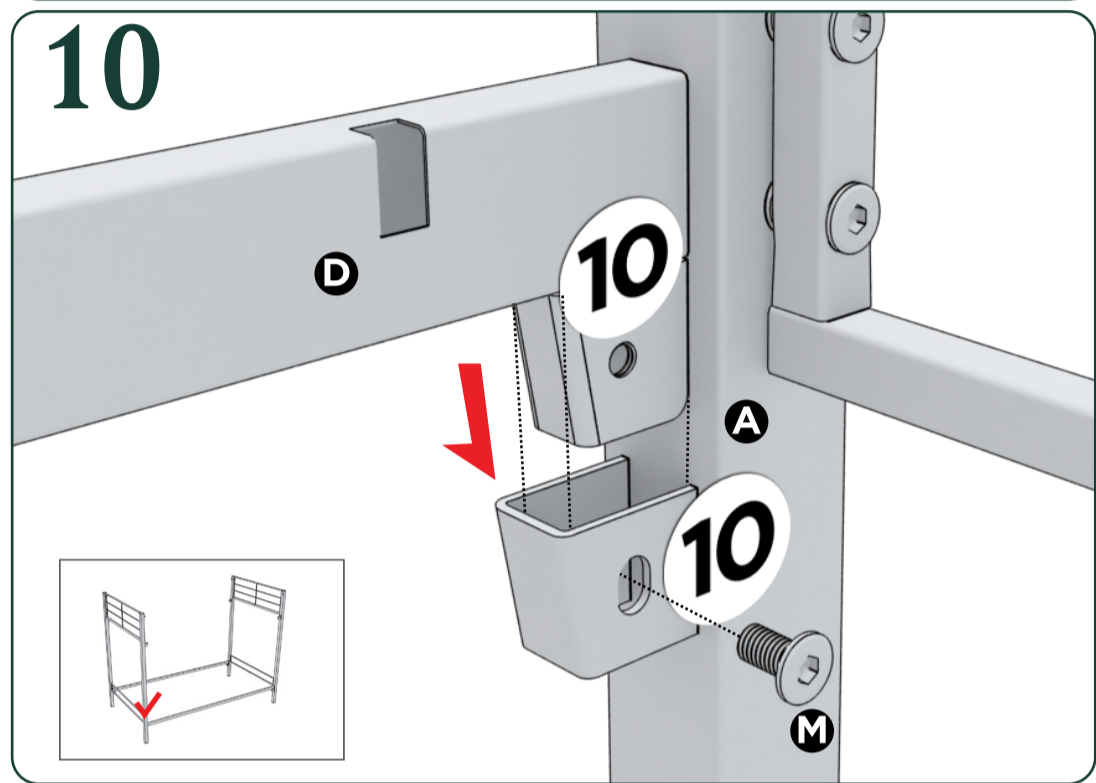
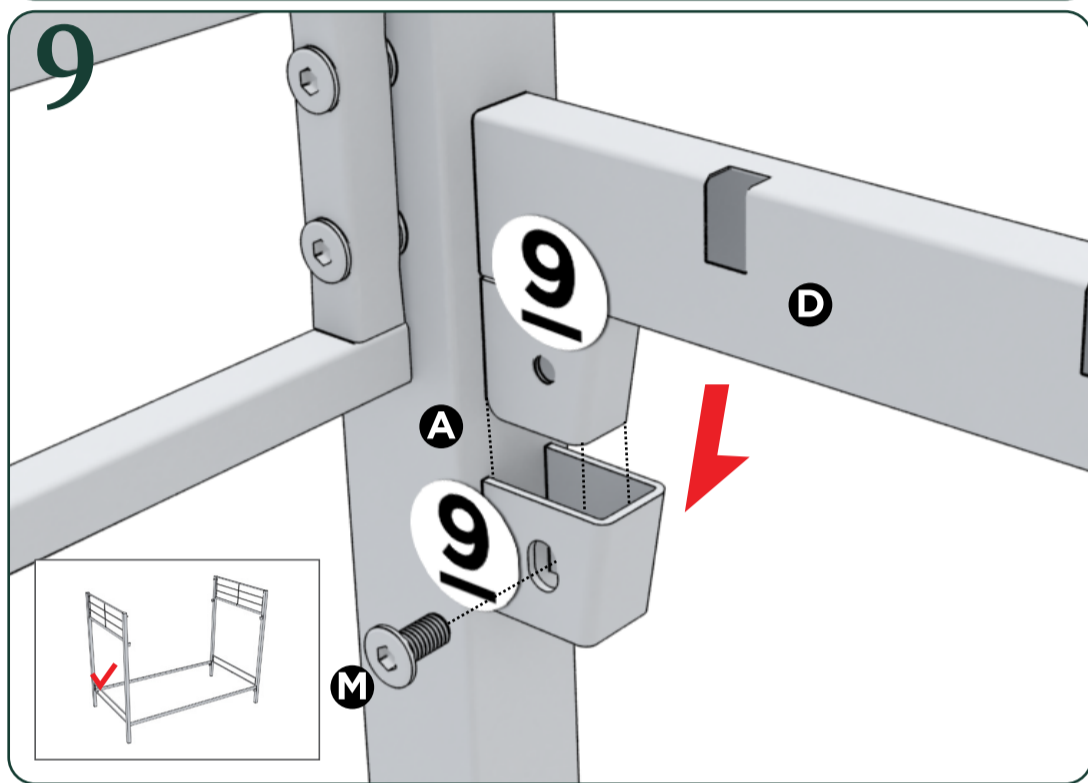
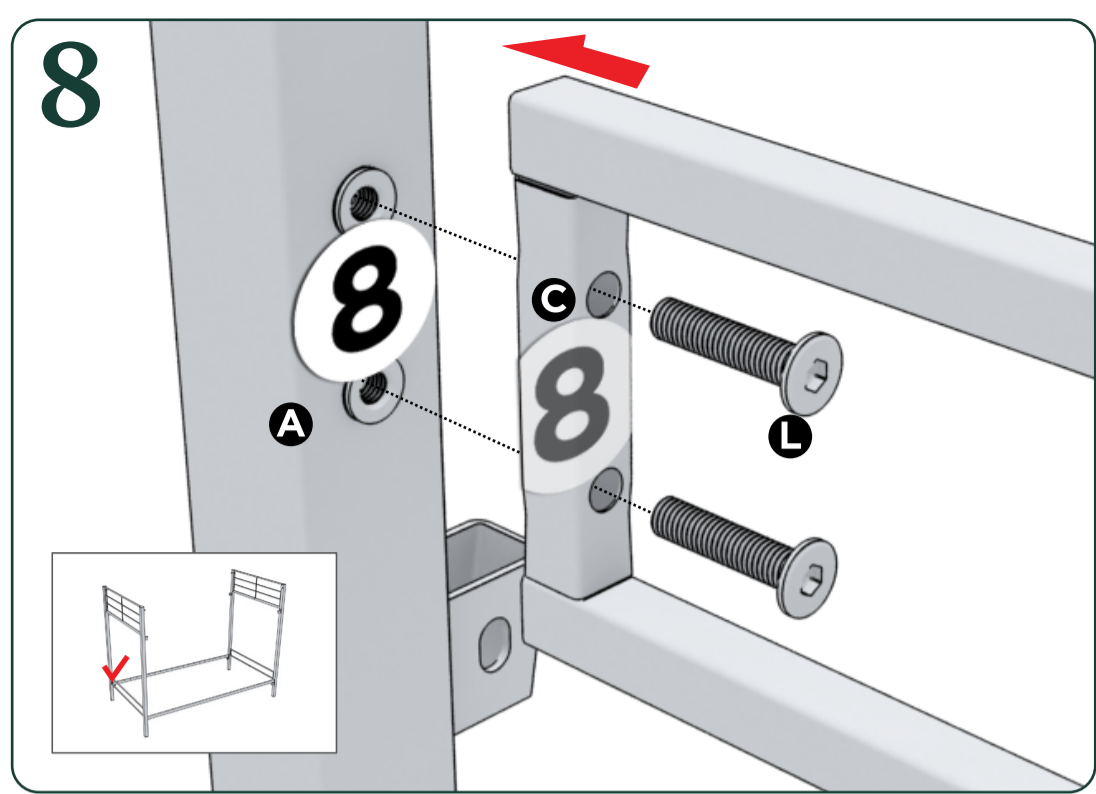
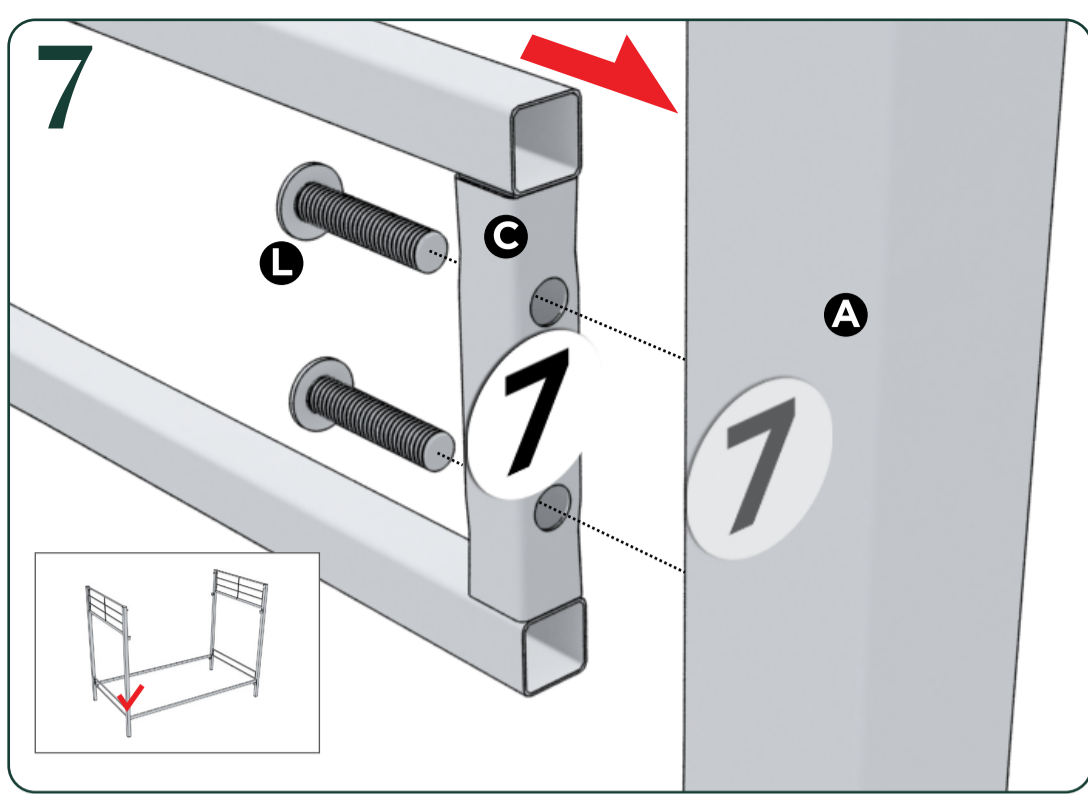

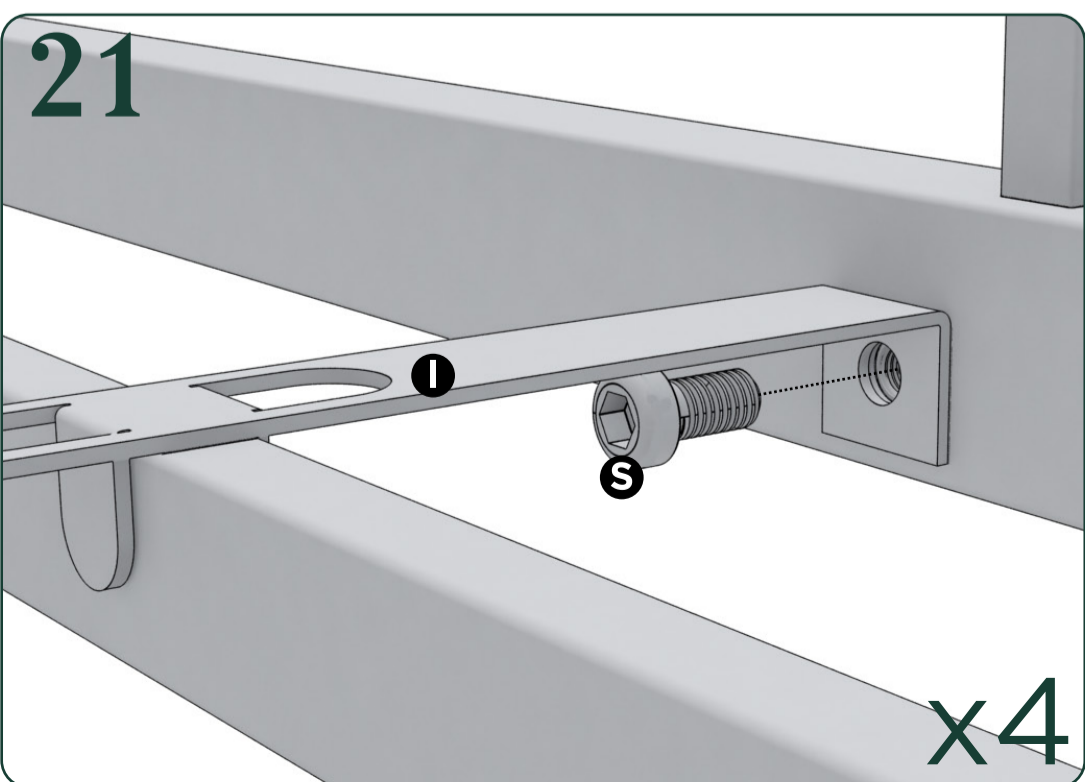
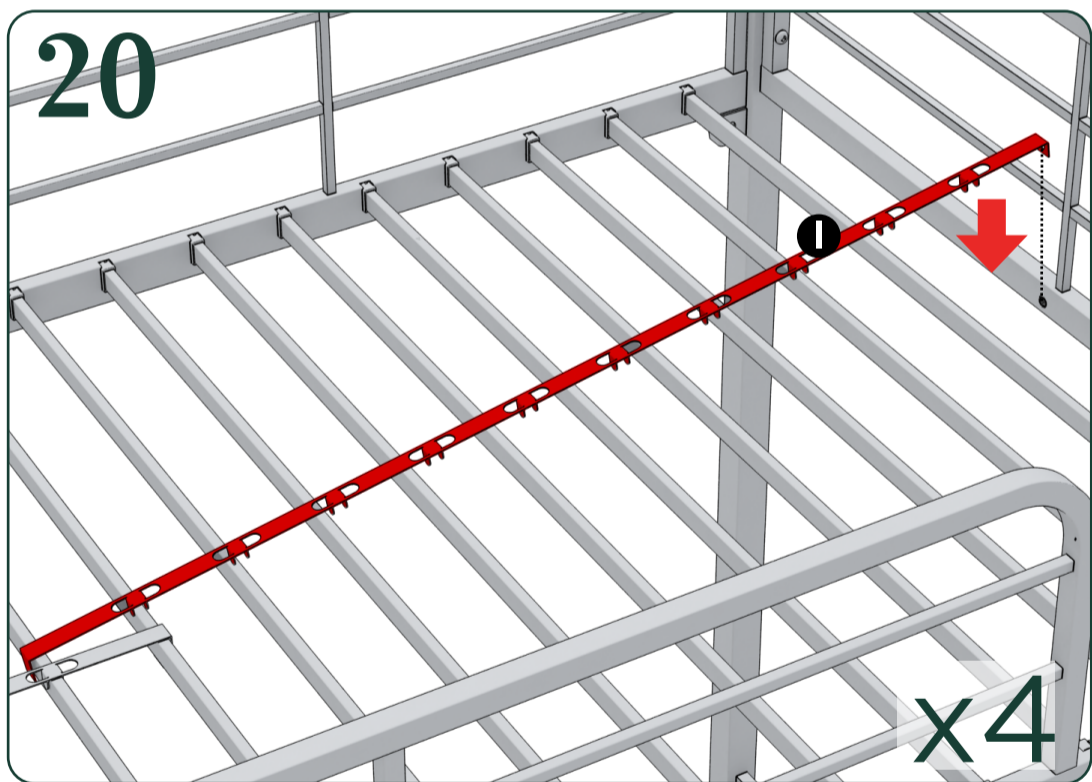
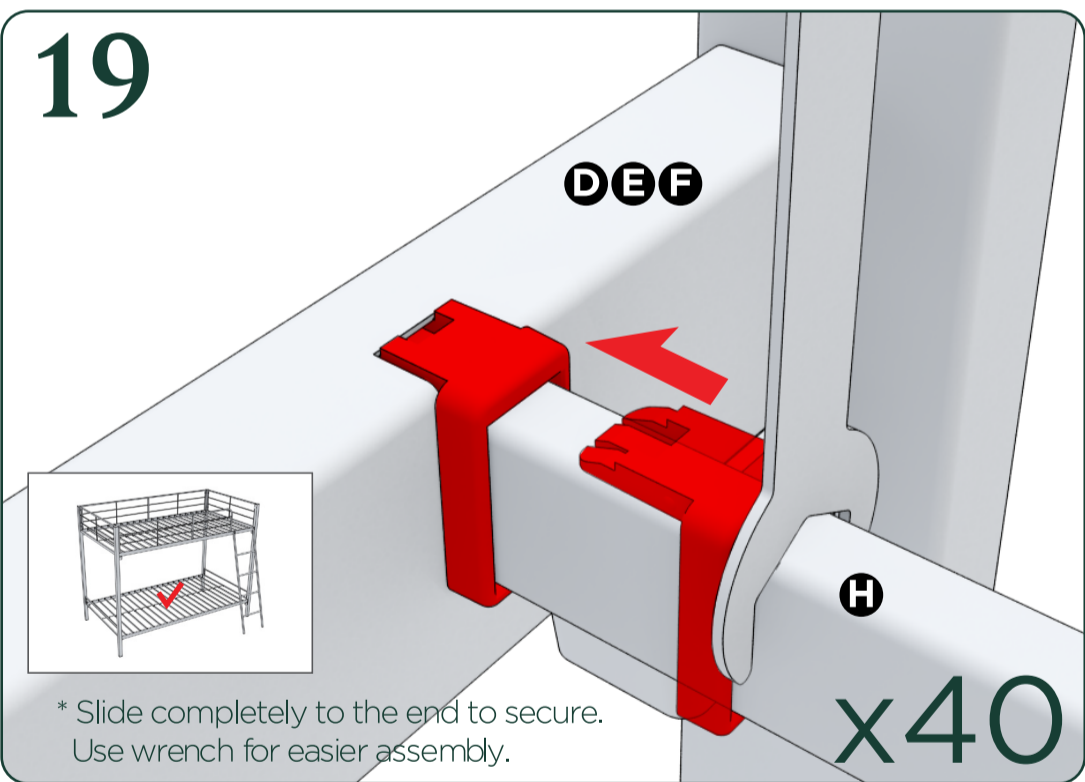
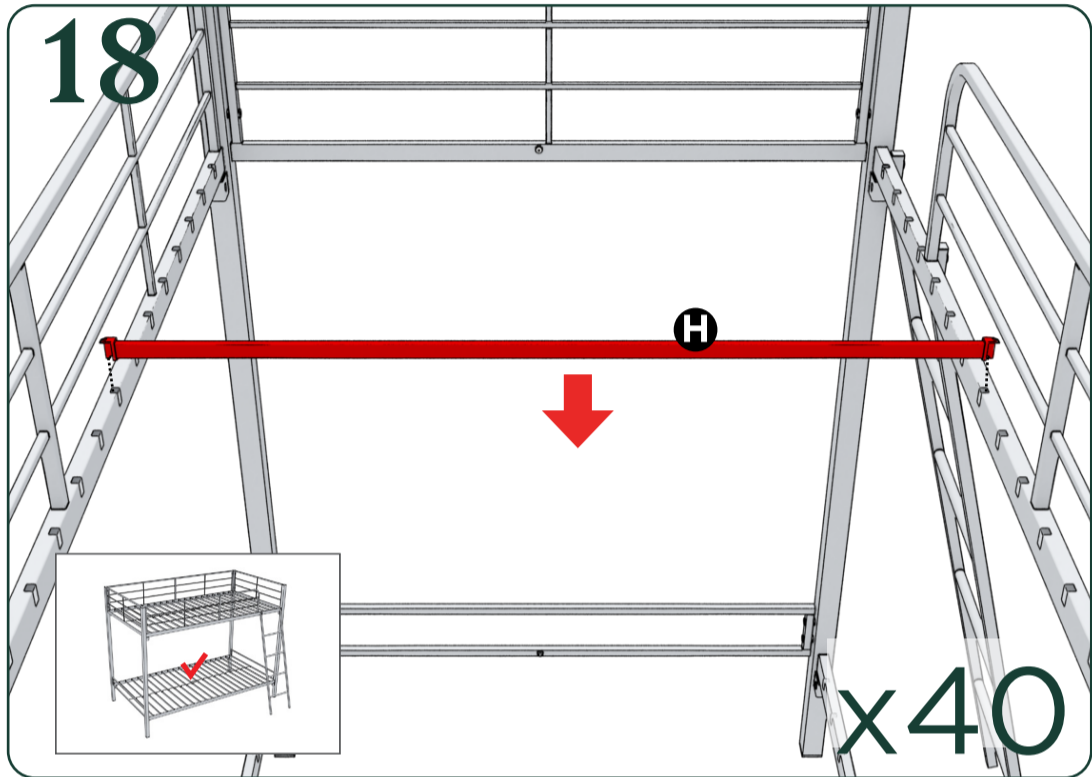
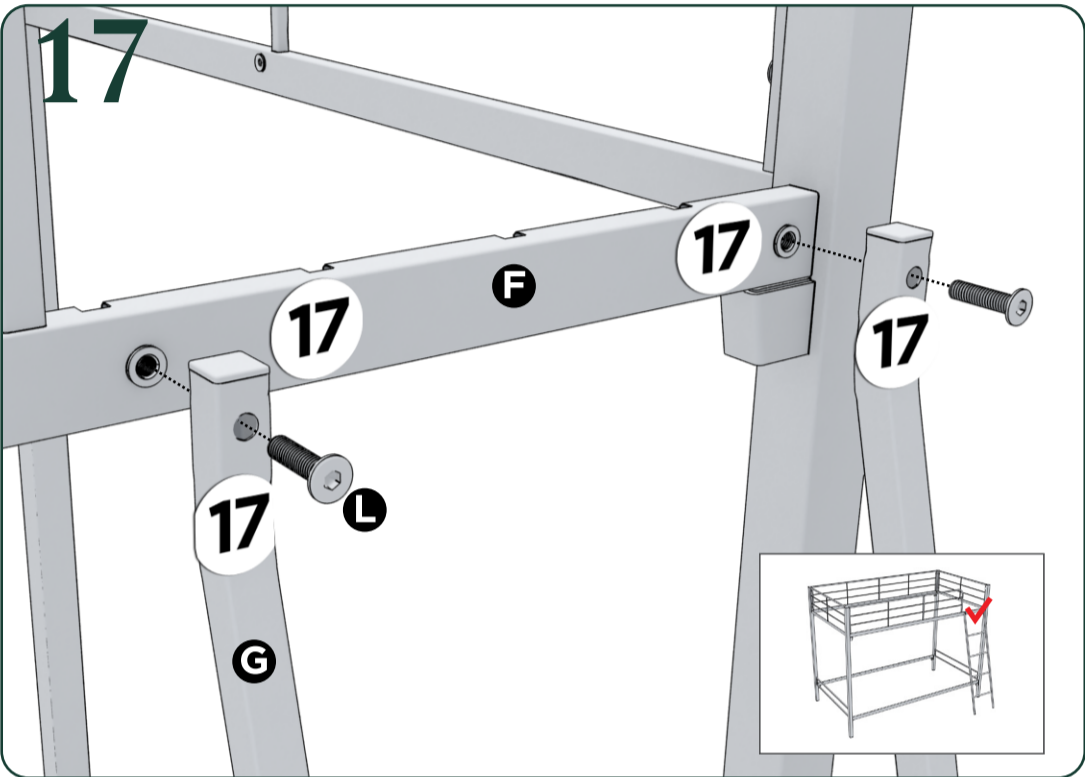
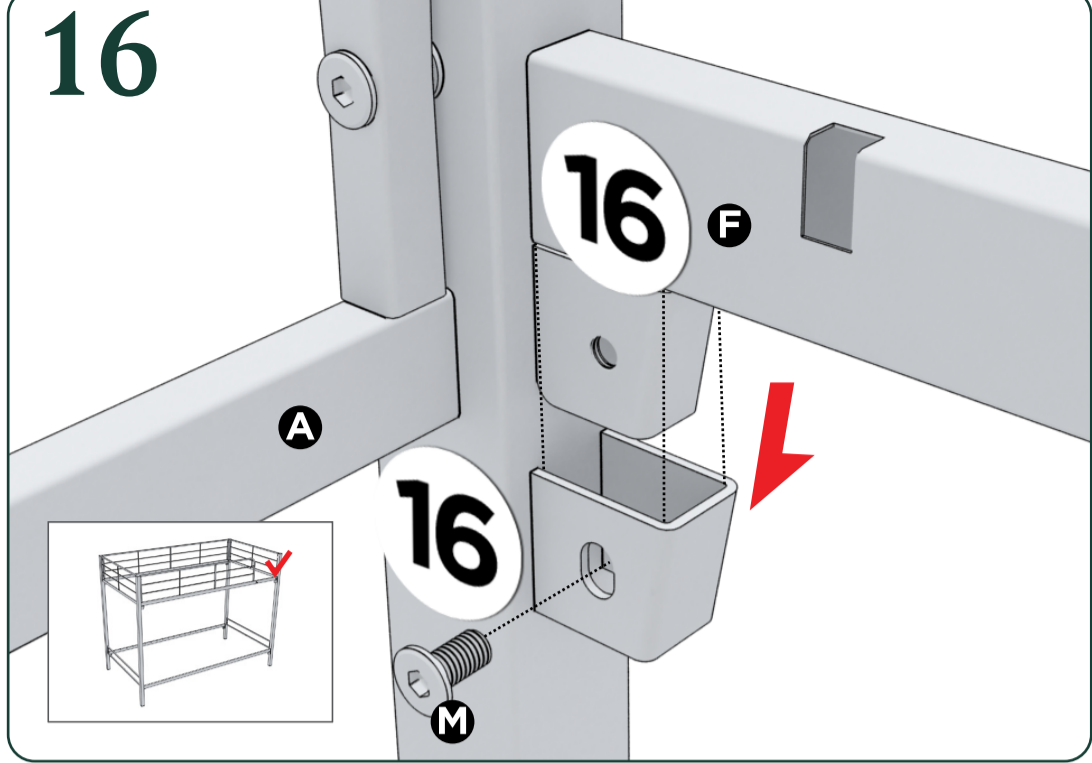
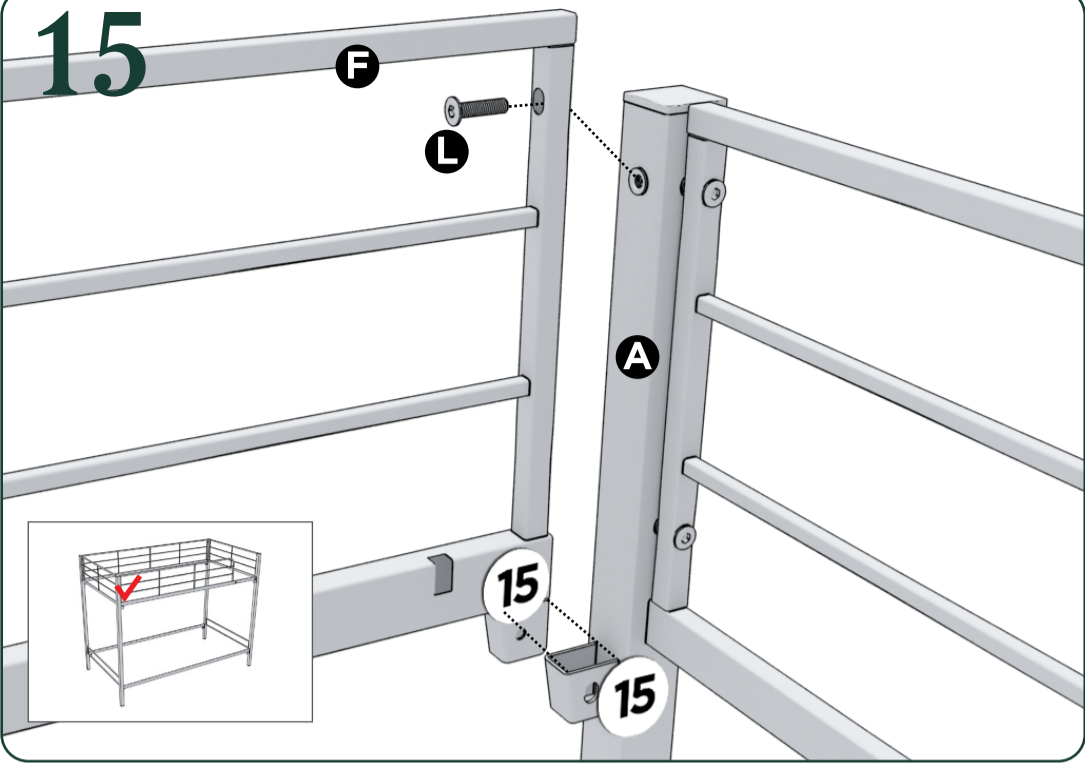

Warning

- **WARNING FOR YOUNG CHILDREN:** THIS PRODUCT CONTAINS SMALL COMPONENTS. PLEASE ENSURE THAT THEY ARE KEPT AWAY FROM SMALL CHILDREN. SMALL INFANTS AND BABIES MUST NOT SLEEP ON THIS BUNK BED FOR SAFETY REASONS. TO PREVENT INJURY AND DAMAGE TO THIS UNIT, PROHIBIT JUMPING ON IT.
- THIS PRODUCT IS DESIGNED FOR HOME USE AND NOT INTENDED FOR COMMERCIAL USE.
- THIS INSTRUCTION BOOKLET CONTAINS IMPORTANT SAFETY INFORMATION. PLEASE READ AND KEEP IT FOR FUTURE REFERENCE.
- FOLLOW THE INFORMATION ON THE WARNINGS APPEARING ON THE UPPER BUNK BED END STRUCTURE AND ON THE CARTON.
- DO NOT REMOVE WARNING LABEL FROM BED.
- THE MATTRESS PLATFORM IS DESIGNED TO SUPPORT A MATTRESS WITHOUT THE NEED FOR A POSTURE BOARD OR BOXSPRING.
- ALWAYS USE THE RECOMMENDED SIZE MATTRESS OR MATTRESS SUPPORT, OR BOTH, TO HELP PREVENT THE LIKELIHOOD OF ENTRAPMENT OR FALLS.
- TO PREVENT INJURY, TWO TWIN SIZE MATTRESSES SHOULD BE USED.
- USE ONLY TWIN MATTRESS WHICH IS 74 1/2"-75" LONG AND 38 1/2"-39" WIDE.
- ENSURE THICKNESS OF MATTRESS AND FOUNDATION COMBINED IS GREATER THAN 4" AND THAT IT DOES NOT EXCEED 6".
- SURFACE OF MATTRESS MUST BE AT LEAST 5" (127MM) BELOW THE UPPER EDGE OF GUARDRAILS.
- DO NOT ALLOW CHILDREN UNDER 6 YEARS OLD TO USE THE UPPER BUNK.
- PERIODICALLY CHECK AND ENSURE THAT THE GUARDRAIL, LADDER AND OTHER COMPONENTS ARE IN THEIR PROPER POSITION, FREE FROM DAMAGE, AND THAT ALL CONNECTORS ARE TIGHT.
- ALWAYS USE THE LADDER FOR ENTERING AND LEAVING THE UPPER BUNK.
- PROHIBIT MORE THAN ONE PERSON ON UPPER BUNK.
- DO NOT USE SUBSTITUTE PARTS, PLEASE CONTACT CUSTOMER SERVICE FOR REPLACEMENT.

- USE OF A NIGHT LIGHT MAY PROVIDE ADDED SAFETY PRECAUTION FOR A CHILD USING THE UPPER BUNK.
- ALWAYS USE GUARDRAILS ON BOTH LONG SIDES OF THE UPPER BUNK, IF THE BUNK BED WILL BE PLACED NEXT TO THE WALL, THE GUARDRAIL THAT RUNS THE FULL LENGTH OF THE BED SHOULD BE PLACED AGAINST THE WALL TO PREVENT ENTRAPMENT BETWEEN THE BED AND WALL.
- THE USE OF WATER OR SLEEP FLOTATION MATTRESSES IS PROHIBITED.
- STRANGULATION HAZARD - NEVER ATTACH OR HANG ITEMS TO ANY PART OF THE BUNK BED THAT ARE NOT DESIGNED FOR USE WITH THE BED, FOR EXAMPLE BUT NOT LIMITED TO, HOOKS, BELTS, AND JUMP ROPES.
- KEEP THESE INSTRUCTIONS FOR FUTURE REFERENCE.

