



Precision Split

Parts Manual

Models

917001 – 27-Ton Log Splitter

917002 – 34-Ton Log Splitter

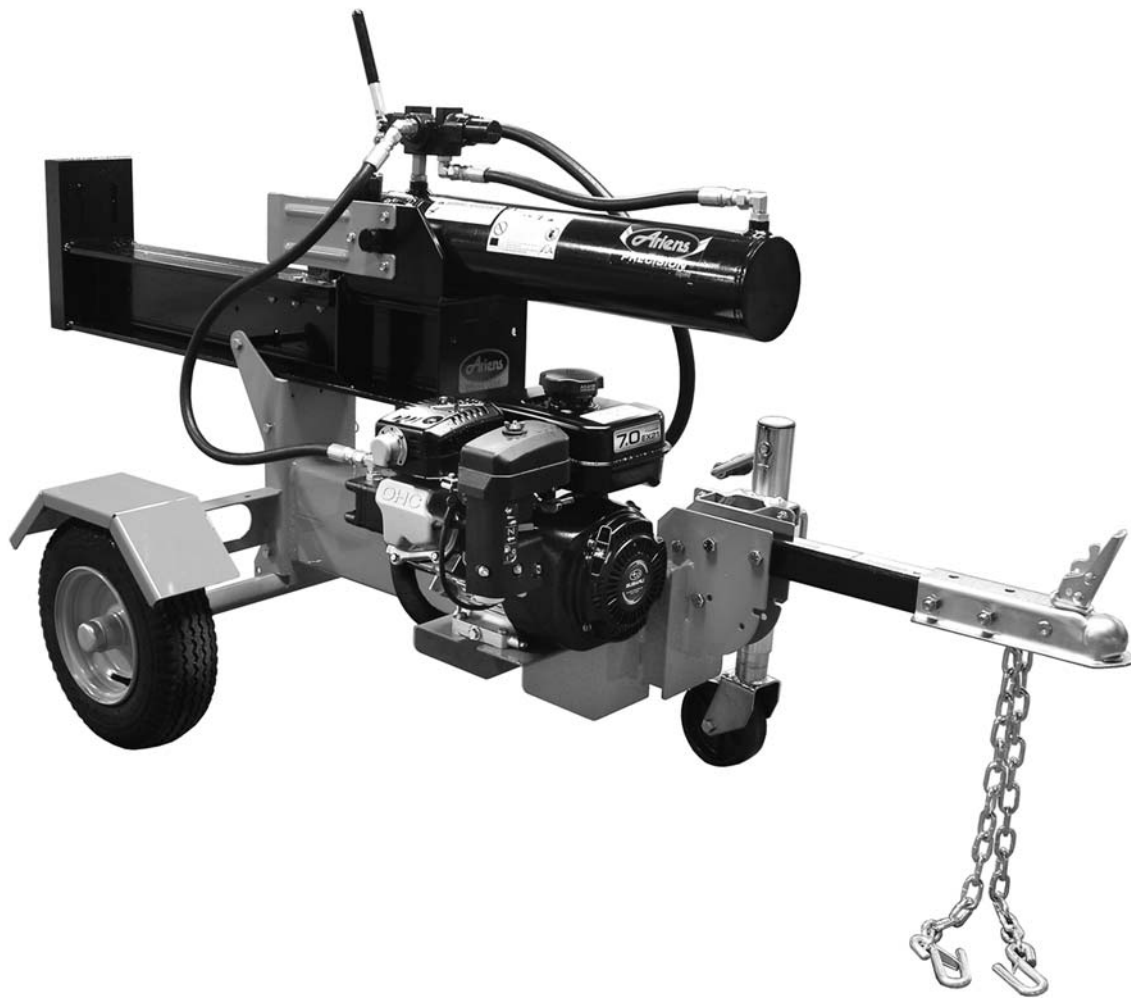

THE MANUAL

Before you operate your unit, carefully and completely read manuals supplied with the unit. The contents will provide you with an understanding of safety instructions and controls during normal operation and maintenance.

For your safety and the safety of others always read, understand, and follow all DANGER, WARNING, and CAUTION messages found in manuals and on safety decals.

Hardware descriptions are given in decimals.

Decimals to Fractions			
.063	1/16	.563	9/16
.125	1/8	.625	5/8
.188	3/16	.688	11/16
.250	1/4	.750	3/4
.313	5/16	.813	13/16
.375	3/8	.875	7/8
.438	7/16	.938	15/16
.500	1/2	1.00	1

SERVICE AND REPLACEMENT PARTS

When ordering replacement parts or making service inquiries, know the Model and Serial numbers of your unit and engine.

Numbers are located on the product registration card in the unit literature package. They are printed on a serial number label, located on the frame of your unit.

- Record Unit Model and Serial numbers here:

UNAUTHORIZED REPLACEMENT PARTS

Use only Ariens replacement parts. The replacement of any part on this vehicle with anything other than an Ariens authorized replacement part may adversely affect the performance, durability, or safety of this unit and may void the warranty. Ariens disclaims liability for any claims or damages, whether warranty, property damage, personal injury or death arising out of the use of unauthorized replacement parts.

PRODUCT REGISTRATION

The Ariens dealer must register the product at the time of purchase. Registering the product will help the company process warranty claims or contact you with the latest service information. All claims meeting requirements during the limited warranty period will be honored, whether or not the product registration card is returned. Keep a proof of purchase if you do not register your unit.

Customer Note: If Dealer does not register your product, please fill out, sign and return the product registration card to Ariens or go to www.ariens.com.

YOUR SATISFACTION IS IMPORTANT

Questions? Please follow these helpful steps:

1. Refer to the manuals supplied with your unit.
They will guide you through safe and proper operation and maintenance.
They contain specifications on your unit.
If your questions are not answered in these manuals, go to step number two.
2. Contact Your Dealer.
Our dealers will be happy to supply any service or advice required to keep your unit operating at peak efficiency.
A factory trained staff is available to support your equipment needs. They stock genuine Ariens parts and lubricants manufactured with the same precision and skill as the original.
If your questions are not resolved by the support staff, ask for the manager or owner.
When contacting your Dealer supply your model and serial numbers.

TO SPEED PARTS ORDERING:

1. Know the model and serial numbers of your unit.
2. Know the part number required.
3. Know the quantity required.
4. Know the part description.

MODEL

Model 917001 (27-Ton Log Splitter)
Serial No. 1000 and up

Model 917002 (34-Ton Log Splitter)
Serial No. 101 and up

TABLE OF CONTENTS

DECALS

Decals – Safety And Operation	4
Decals – Style	5

LOG SPLITTER

Beam And Hydraulic Cylinder	6
Frame, Engine And Pump	8
Accessories	10
Hydraulic Diagram	13

DECALS – SAFETY AND OPERATION

Model 917001, 002

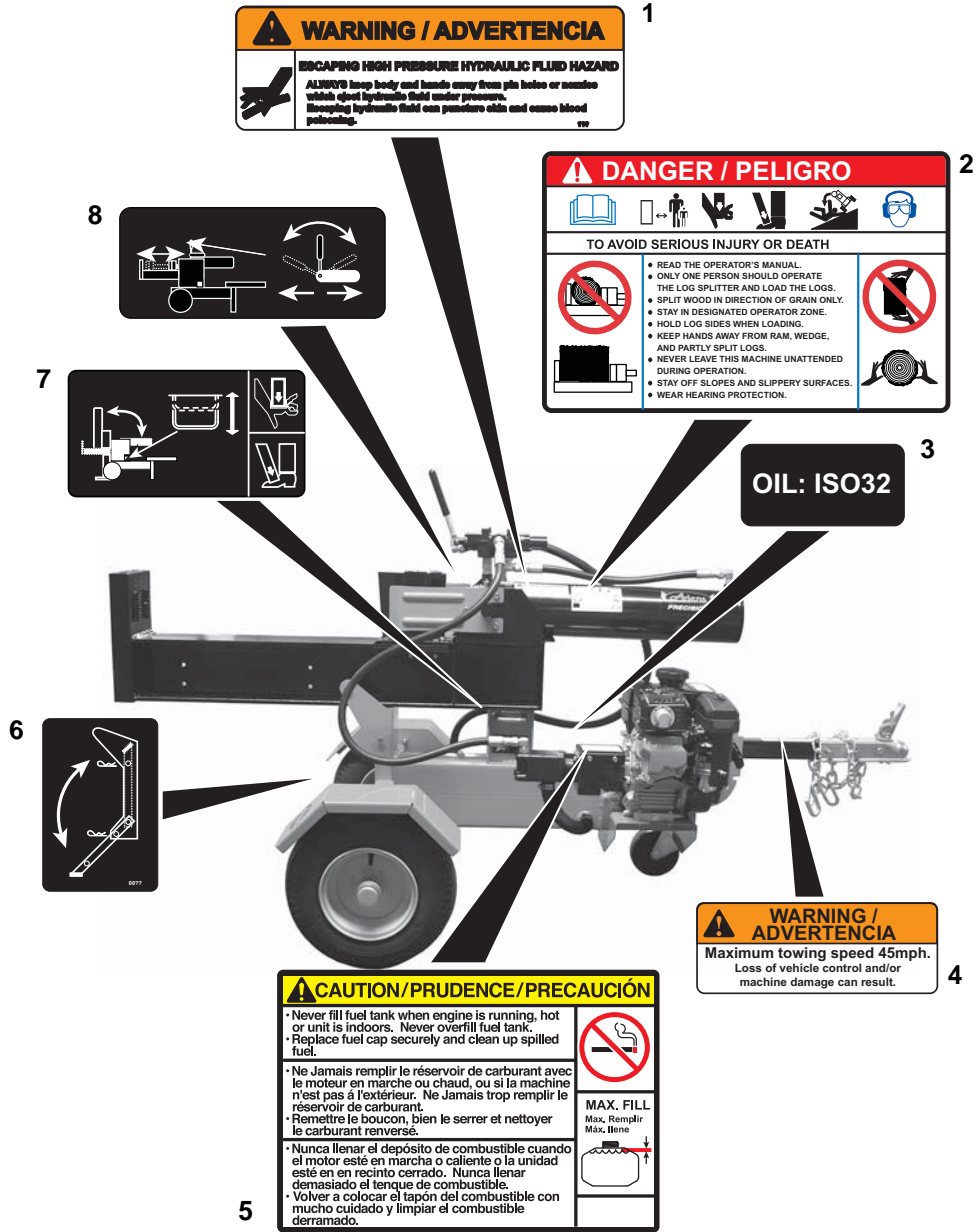

Item	Part No.	Qty.	Description
1	08000310	1	Decal, Log Splitter Hydraulic Warning
2	08000309	1	Decal, Log Splitter Danger
3	08000313	2	Decal, Log Splitter Hydraulic Oil
4	08000312	2	Decal, Log Splitter Towing
5	08000311	1	Decal, Log Splitter Gas Caution
6	08000316	1	Decal, Log Splitter Rear Stand
7	08000315	1	Decal, Log Splitter Tilt Operation
8	08000314	1	Decal, Log Splitter Ram Operation
9	61700500	AR	Decal Sheet (Includes Items 1 – 8)

PC0800

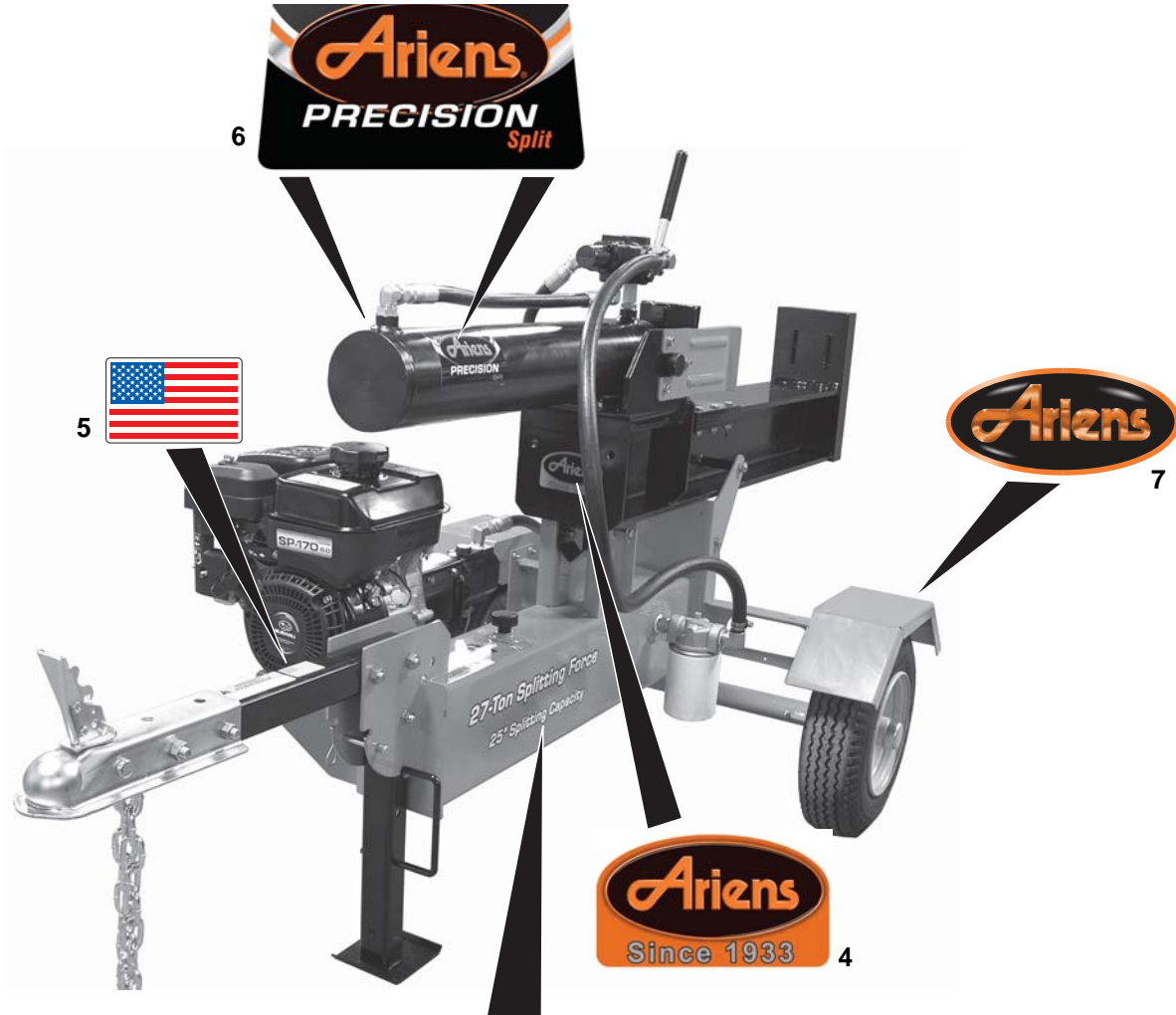

3 **34-Ton Splitting Force**
 2 **27-Ton Splitting Force**
 1 **25" Splitting Capacity**

PC0802

Item	Part No.	Qty.	Description
1	08000318	1	Decal, Log Splitter 25" Length
2	08000319	1	Decal, Log Splitter – 27 Tons (917001)
3	08000320	1	Decal, Log Splitter – 34 Tons (917002)
4	08000303	1	Decal, Ariens Since 1933 Large
5	05305100	1	Decal, American Flag
6	08000324	2	Decal, Precision Log Splitter
7	02995900	2	Decal, Ariens Jewel, Large

BEAM AND HYDRAULIC CYLINDER

Model 917001, 002

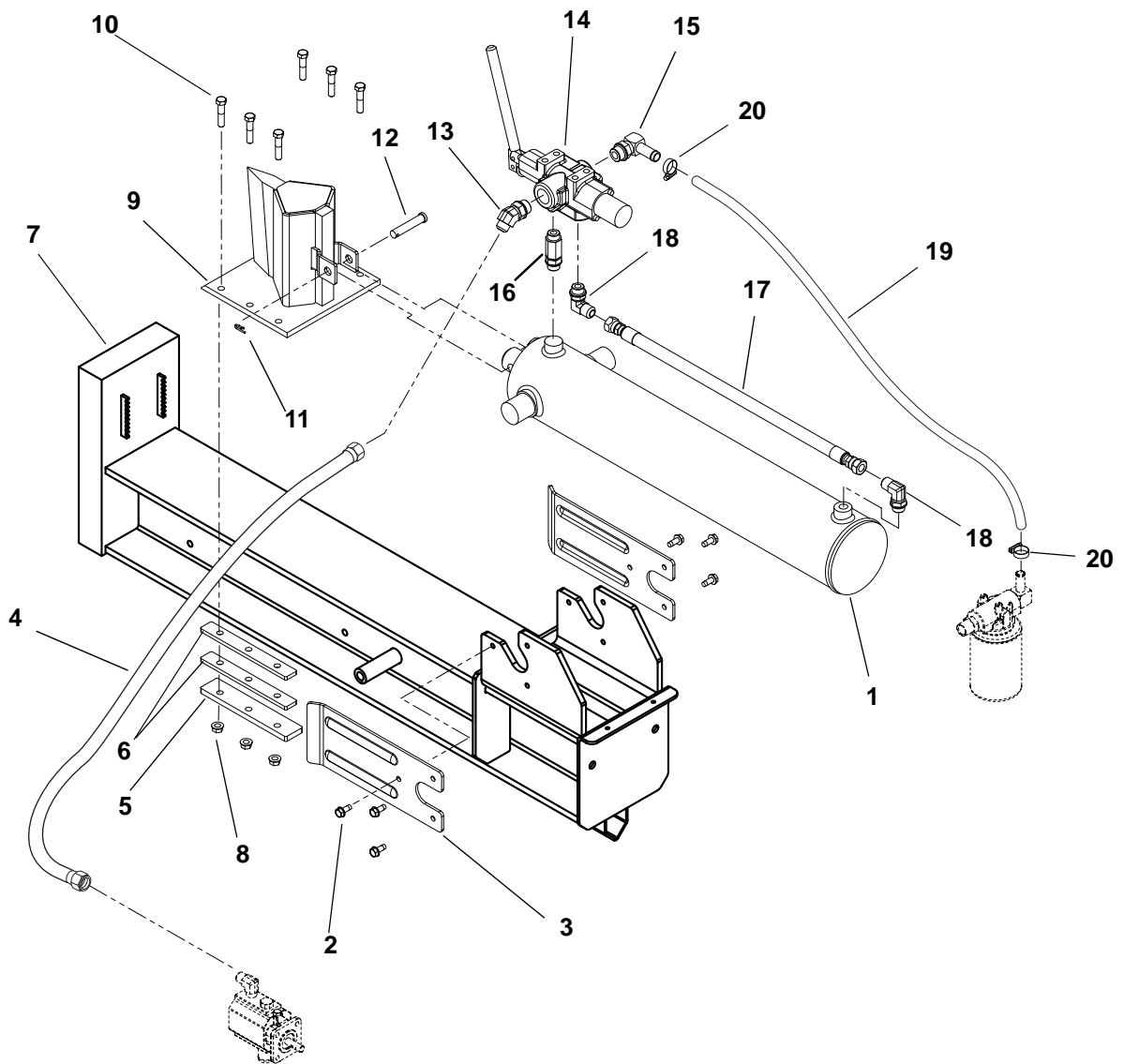

PC0810

BEAM AND HYDRAULIC CYLINDER

Model 917001, 002

Item	Part No.	Qty.	Description
1	51700200	1	Cylinder, 4.5-Inch With Decals (917001)
	51700700	1	Cylinder, 5-In. With Decals (917002)
2	07414400	6	Screw, Tapping .31-18 x .75 Hex Washer Head Thread Rolling
3	03857359	2	Plate, Stripper
4	07001539	1	Hose Assembly, 8M3K-8FJX-8FJX-46
5	03857751	2	Retainer, Wedge
6	03857651	4	Spacer, Wedge
7	03835851	1	Beam, Splitter
8	06542000	6	Nut, Locking Top Flange .38-16
9	03835951	1	Wedge, Splitter
10	05958500	6	Bolt, Hex .38-16 x 1.75
11	06944800	1	Clip, Spring
12	06810700	1	Pin, Clevis .494 x 2.50, Bright Zinc Plating
13	07001537	1	Fitting, Hydraulic 6802-8-10
14	03846300	1	Valve, Splitter Control
15	07001538	1	Fitting, Hydraulic 4601-10-10
16	07001534	1	Fitting, Hydraulic 6403-NWO-8--8-L
17	07001540	1	Hose Assembly, 8M3K-8FJX-8FJX-22
18	07001535	2	Fitting, Hydraulic 6801-8-8
19	03859600	1	Hose, Hydraulic Return 10LOLA x 53-In.
20	06923500	2	Clamp, .88 Diameter

FRAME, ENGINE AND PUMP

Model 917001, 002

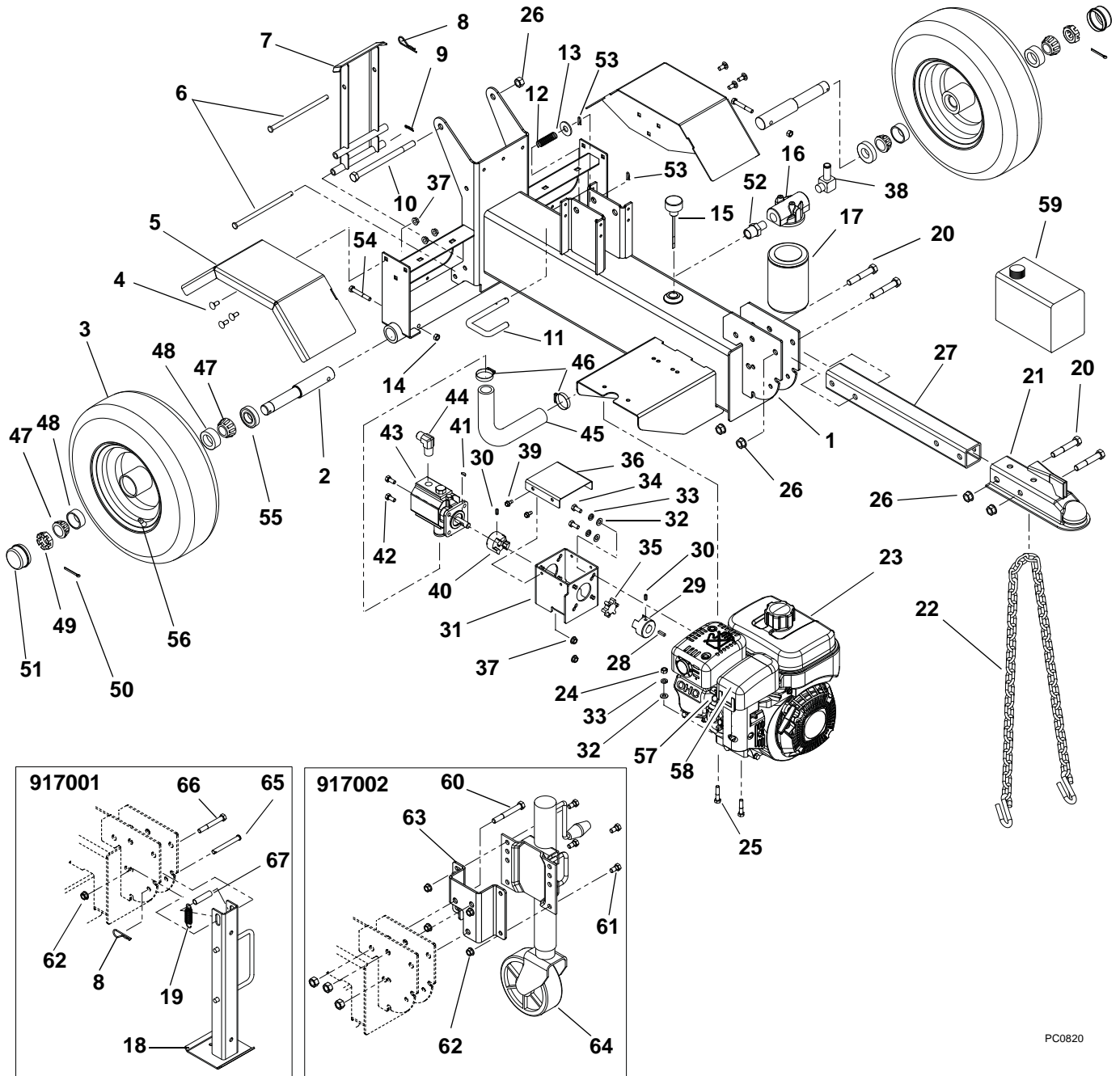

Item	Part No.	Qty.	Description
1	51700800	1	Chassis, Splitter With Safety Decal
2	03857000	2	Axle, Splitter
3	07100806	2	Wheel, Splitter (Includes Items 47, 48, 55 and 56)
4	06215700	6	Bolt, Round Head Square Neck .31-18 x .75
5	03857159	2	Fender
6	03857200	2	Pin, Lock
7	51700400	1	Stand, Rear With Decals
8	06712900	2	Hairpin, #7 Clip .094 x .31 (917001)
	06712900	1	Hairpin, #7 Clip .094 x .31 (917002)
9	06714800	1	Pin, Hair #25
10	05978200	1	Bolt, Hex .50-13 x 7.50
11	03857500	1	Lock, Beam

PC0820

FRAME, ENGINE AND PUMP

Model 917001, 002

12	08325900	1	Spring, Compression .058 x .65 x 2.13
13	06442000	1	Washer, Flat Steel .563 x 1.38 x .109
14	06529800	2	Nut, Locking Center .31-18
15	00463000	1	Breather, Dipstick
16	03846800	1	Head, Filter .75 NPT
17	03931900	1	Element, Filter Zinga AE-25
18	03938151	1	Stand, Jack (917001)
19	08300435	1	Spring, Tension .063 x .625 x 2.50 (917001)
20	05959900	4	Bolt, Hex .50-13 x 3.00 (917001)
	05959900	3	Bolt, Hex .50-13 x 3.00 (917002)
21	03846600	1	Hitch, Ball 2-Inch
22	03846700	1	Chain, Safety
23	08200429	1	Engine, Subaru SP170, CARB (917001)
	08200517	1	Engine, Subaru EX21, CARB (917002)
24	06529200	4	Nut, Hex .31-18
25	05952400	4	Bolt, Hex .31-18 x 1.50
26	06536300	5	Nut, Locking Center .50-13 (917001)
	06536300	7	Nut, Locking Center .50-13 (917002)
27	51700500	1	Bar, Hitch With Decals
28	06606100	1	Key, Square .188 x .75 x .188
29	03856100	1	Hub, Drive Coupling 3/4 Inch
30	06001100	2	Screw, Set .25-20 x .38 Socket Head Cup Point Nyloc
31	03858351	1	Bracket, Pump Mount
32	06437200	8	Washer, Flat Steel .344 x .688 x .065
33	06307400	8	Washer, Locking .312 x .097 Heavy
34	05947300	4	Bolt, Hex .31-24 x .75
35	03856200	1	Spider, Urethane
36	51700600	1	Cover, With Decals
37	06543100	10	Nut, Locking Top Flange .31-18
38	07001602	1	Fitting, Hydraulic 4501-10-12-FG
39	07400034	4	Screw, Tapping .25-20 x .50 Hex Washer Head Thread Rolling
40	03856300	1	Hub, Drive Coupling 1/2 Inch
41	06600004	1	Key, Woodruff .125 x .50 x .20
42	05947000	4	Bolt, Hex .31-18 x .75
43	03846400	1	Pump, Splitter 11 GPM (917001)
	03874000	1	Pump, Splitter 13 GPM (917002)
44	07001536	1	Fitting, Hydraulic 2501-8-8 (917001)
	07001535	1	Fitting, Hydraulic 6801-8-8 (917002)
45	03859700	1	Hose, Hydraulic Suction 16G4H x 10.5
46	06922200	2	Clamp, Hose 1.50 x .81 x 1.42
47	69000300	4	Bearing, Cone With Grease
48	05407000	4	Bearing, Cup 1.980 x .420
49	06513100	2	Nut, Slotted 1.0-14
50	06713800	2	Pin, Center .15 x 1.50
51	20655400	2	Cap, Dust
52	07001601	1	Fitting, Hydraulic 5404-12-12
53	06944800	2	Clip, Spring
54	05963700	2	Bolt, Hex .31-18 x 2.25
55	00092498	2	Seal
56	07520000	2	Valve Stem Assembly
57	20020001	2	Spark Plug
58	20020002	1	Filter, Air
59	00069100	AR	Oil, Hydraulic 2.5 Gallon ISO Grade 32
60	05960000	3	Bolt, Hex .50-13 x 3.25 (917002)
61	05959400	4	Bolt, Hex .38-16 x .75 (917002)
62	06542000	1	Nut, Locking Top Flange .38-16 (917001)
	06542000	4	Nut, Locking Top Flange .38-16 (917002)
63	03938259	1	Bracket, Mounting (917002)
64	03938300	1	Stand, Jack With Wheel (917002)
65	02747500	1	Pin, Clevis .368/.373 x 3.25 (917001)
66	05957800	1	Bolt, Hex .38-16 x 3.00 (917001)
67	05533500	1	Spacer, Wheel (917001)

ACCESSORIES

Model 917001, 002

Work Table Kit 71701200

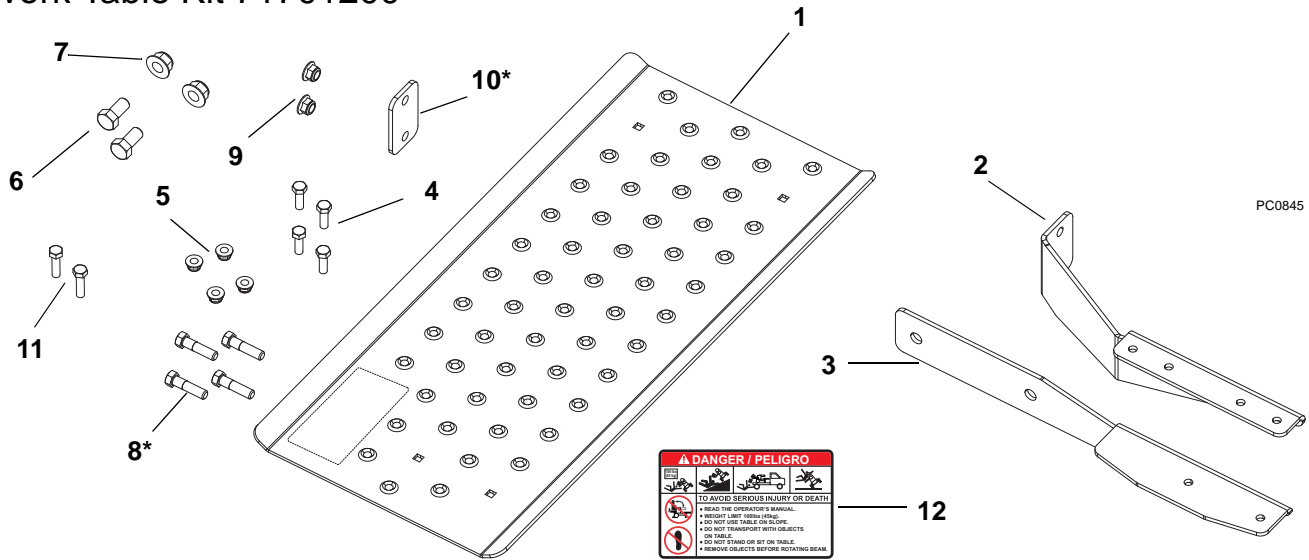

Item	Part No.	Qty.	Description
1	03880159	1	Bracket, Work Table
2	03880251	1	Bracket, Rear Table Mount
3	03880351	1	Bracket, Front Table Mount
4	06200007	4	Bolt, Round Head Square Neck .312-18 x 1
5	06545400	4	Nut, Nyloc Flange.312-18
6	05947100	2	Bolt, Hex .50-13 x 1
7	06543600	2	Nut, Locking Top Flange .50-13
8	05957900*	4	Bolt, Hex .38-16 x 1.5
9	06542000	2	Nut, Locking Top Flange .38-16
10	03886751*	1	Spacer Plate, Work Table
11	05958000	2	Bolt, Hex .38-16 x 1.25
12	08000406	1	Decal, Work Table

* For use with installation of Log Cradle Kit (71701600).

Light Harness Kit 71701300



Item	Part No.	Qty.	Description
1	03888300	1	Wiring Harness, Trailer Light Kit
2	03888400	2	Housing, Tail Light With Bulb
3	03888500	2	Grommet, Tail Light Mounting

ACCESSORIES

Model 917001, 002

License Plate Light Kit 71701400

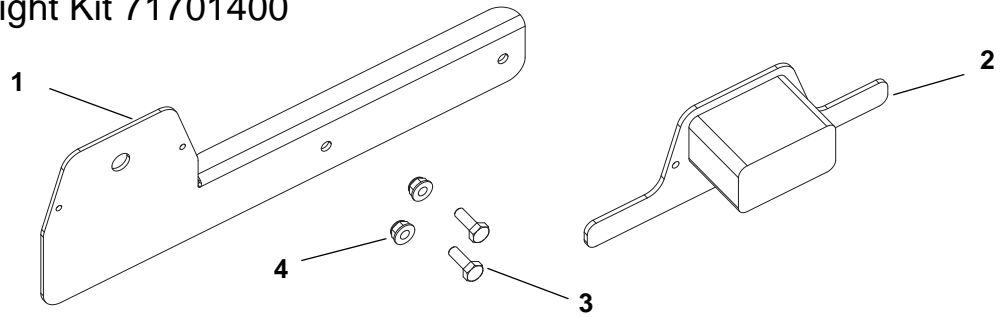

PC0850

Item	Part No.	Qty.	Description
------	----------	------	-------------

1	03910251	1	Bracket, License Plate (Ships preassembled with item 2)
2	03888600	1	Light (Ships preassembled with item 1)
3	05946800	2	Bolt, Hex .25-20 x .75
4	06500012	2	Nut, Nyloc Flange.25-20

Engine Cover Kit 71701500



PC0855

Item	Part No.	Qty.	Description
------	----------	------	-------------

1	03888900	1	Cover, Engine
---	----------	---	---------------

Log Cradle Kit 71701600

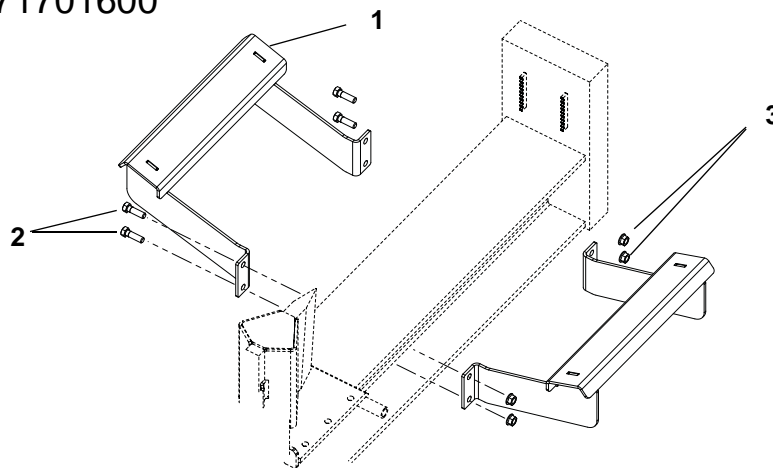

PC0825

Item	Part No.	Qty.	Description
------	----------	------	-------------

1	03863051	2	Cradle, Log
2	05958000	4	Bolt, Hex .38-16 x 1.25
3	06542000	4	Nut, Locking Top Flange .38-16

ACCESSORIES

Model 917001, 002

Handle Kit 71701800

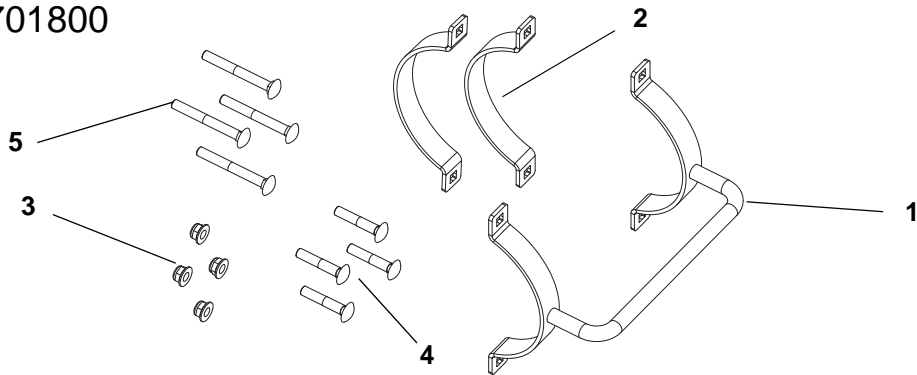

PC0860

Item	Part No.	Qty.	Description
1	03897651	2	Weldment, Hydraulic Cylinder Clamp
2	03897851	4	Bracket, Cylinder Clamp
3	05958000	1	Nut, Nyloc Flange .312-18
4	06200112	1	Bolt, Round Head Square Neck .312-18 x 2.75 (917002)
5	06220200	1	Bolt, Round Head Square Neck .312-18 x 1.75 (917001)

HYDRAULIC DIAGRAM

Model 917001, 002

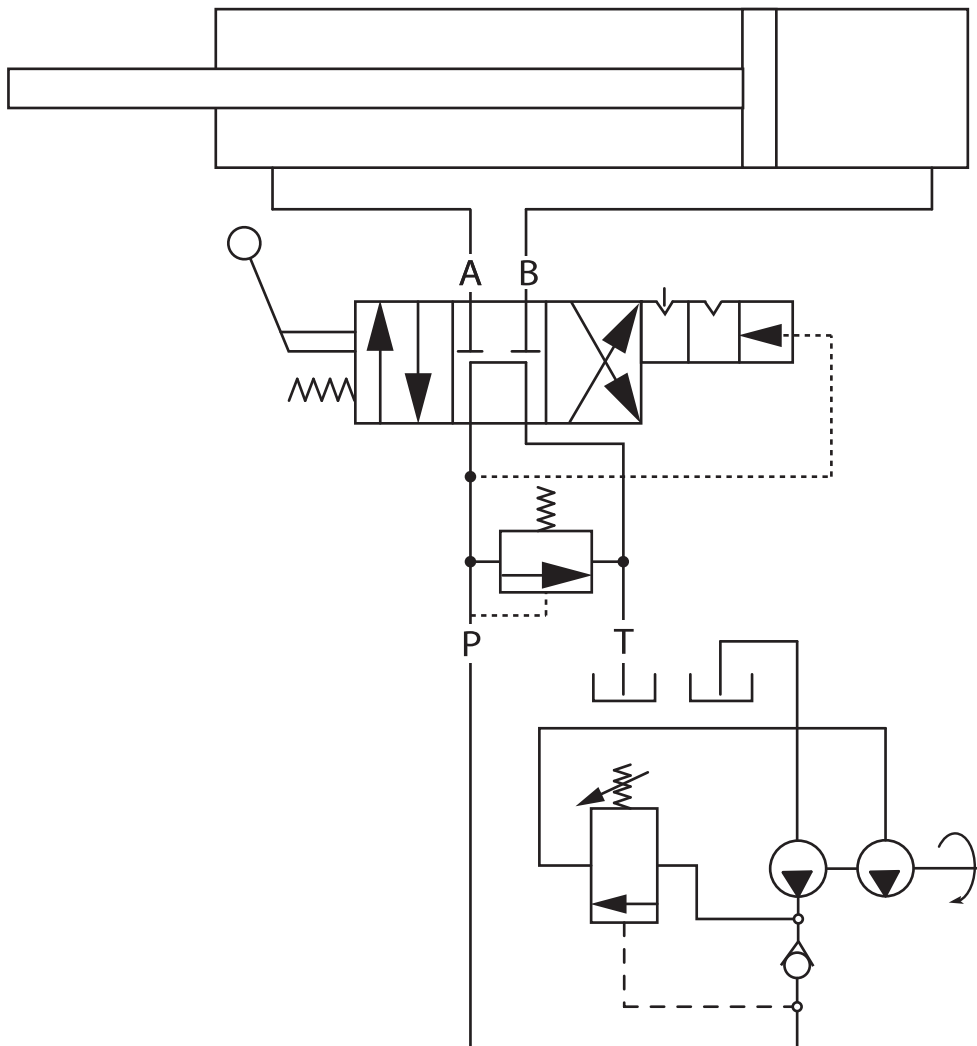

PC0835



Ariens Company
655 West Ryan Street
Brillion, WI 54110-1072
920-756-2141
Fax 920-756-2407
www.ariens.com