

Item # 1002 211 009
Model # GFM00469A-CPY

HAMPTON BAY[®]

USE AND CARE GUIDE

ARCHED PERGOLA REPLACEMENT CANOPY

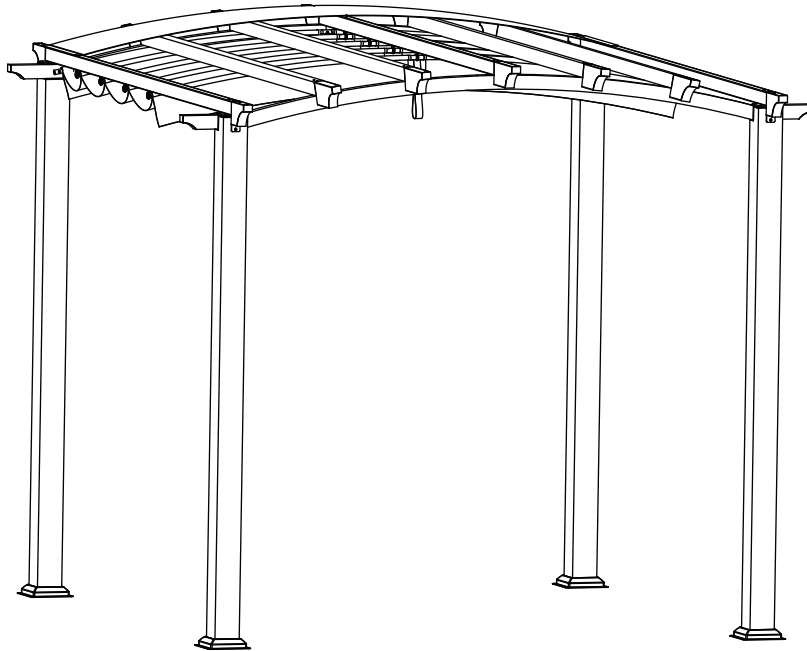

Questions, problems, missing parts? Before returning to the store,
call Hampton Bay Customer Service.

8 a.m. - 7 p.m., EST, Monday - Friday, 9 a.m. - 6 p.m., EST, Saturday

1-855-HD-HAMPTON

HAMPTONBAY.COM

THANK YOU

We appreciate the trust and confidence you have placed in Hampton Bay through the purchase of this replacement canopy. We strive to continually create quality products designed to enhance your home. Visit us online to see our full line of products available for your home improvement needs. Thank you for choosing Hampton Bay!

Table of Contents

Table of Contents.....	2	Package Contents.....	3
Safety Information	2	Assembly.....	4
Safety Warnings	2	Care and Cleaning.....	7
Warranty	2		
What is Covered	2		
What is Not Covered	2		
Pre-Assembly	2		
Planning Assembly	2		

Safety Information

SAFETY WARNINGS

 **WARNING:** Keep all flame and heat sources away from this gazebo fabric.

 **WARNING:** This application of any foreign substance to the gazebo fabricc may render the flame resistant properties ineffective.

 **WARNING:** This gazebo is made with fabric that meets CPAI - 84 specifications for flame resistance. It is not fire proof. The fabric will burn if left continuous contact with any flame source.

Warranty

2 YEAR FABRIC WARRANTY

WHAT IS COVERED

We warrant the fabric to be free of manufacturing defects to the original purchaser for two years.

WHAT IS NOT COVERED

It remains the customer’s responsibility for freight and packaging charges to and from our service center. This warranty does not cover commercial use, hardware, acts of nature, fire, freezing and abusive use. In addition, purchased parts are not covered under this warranty. We reserve the right to make substitutions with similar merchandise, if the model in question is no longer in production.

Contact the Customer Service Team at 1-855-HD-HAMPTON or visit www.HamptonBay.com

Pre-Assembly

PLANNING ASSEMBLY

Read all instructions before assembly.

To avoid damaging this product, assemble it on a soft, non-abrasive surface such as carpet or cardboard.

 **NOTE:** More than one person may be required to complete the assembly of this product.

Pre-Assembly (continued)

PACKAGE CONTENTS

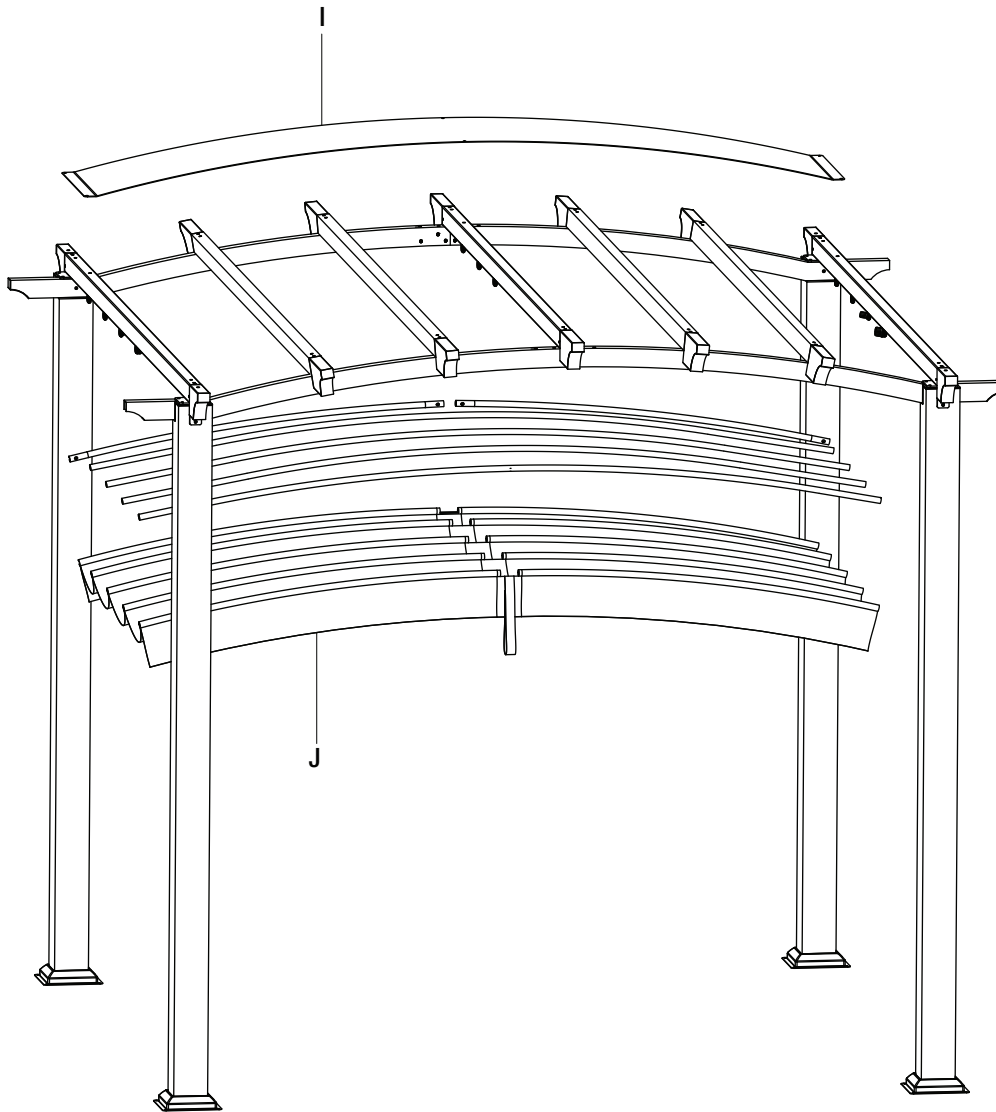

Part	Description	Quantity
I	Protective cover	1
J	Fabric shade	1

Assembly

1 Inserting the short shade rods into the fabric shade

- Insert the short shade rods (F) into the top slots of the fabric shade (J).

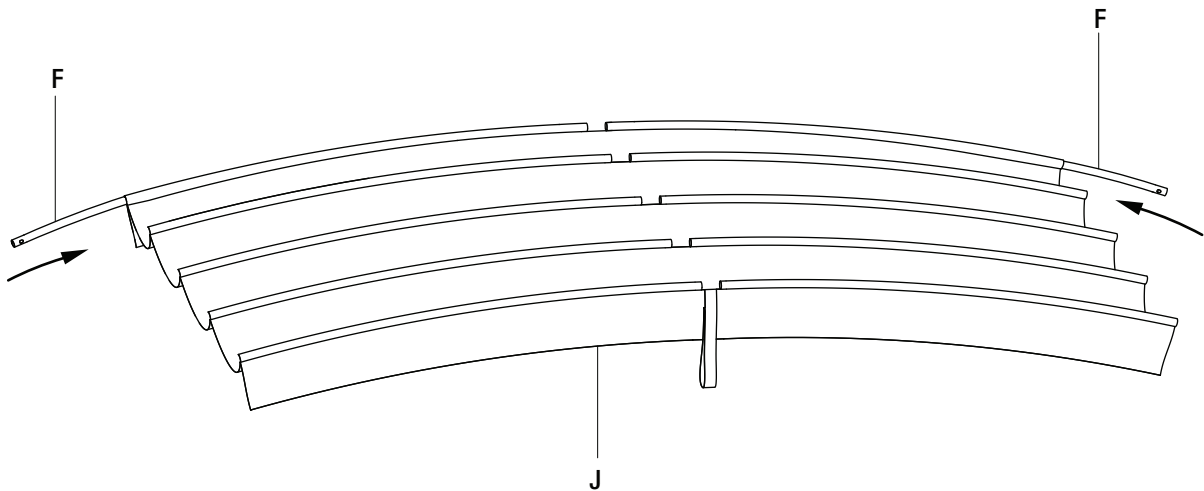

Assembly (continued)

2 Attaching the short shade rods

- Attach the four ends of the short shade rods (F) to the front connector bars (A & B) using M6x35 combination bolts (CC).
- Pull out the elastic ribbons on the two fabric slot ends, as shown on 2-4.

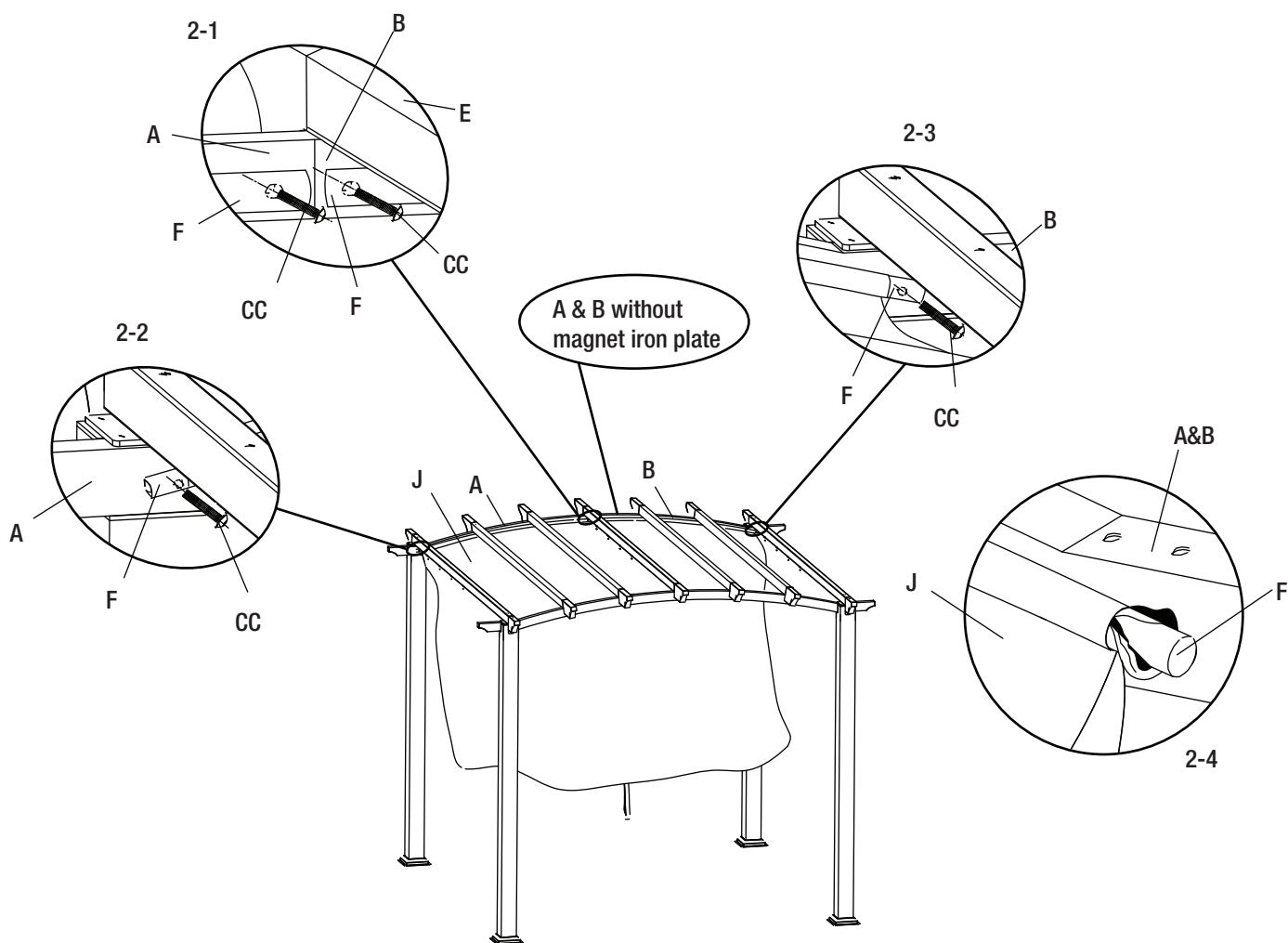

Assembly (continued)

3 Connecting the long shade rods

- Insert the long shade rods (G) into the slots at the ends of the fabric shades (J), through the plastic wheels (E1) and rolling wheel (E2), into the remaining slots of the fabric shades (J).
- Pull the elastic ribbons to the plastic wheel on the side top bar (D), as shown on 3-3 and 3-4.
- Attach the long shade rods (G) to the plastic wheels (L1) on the other side top bar (D), and secure with M6x18 countersunk bolts (BB).



NOTE: Fully tighten all the bolts using the hex wrench (FF).

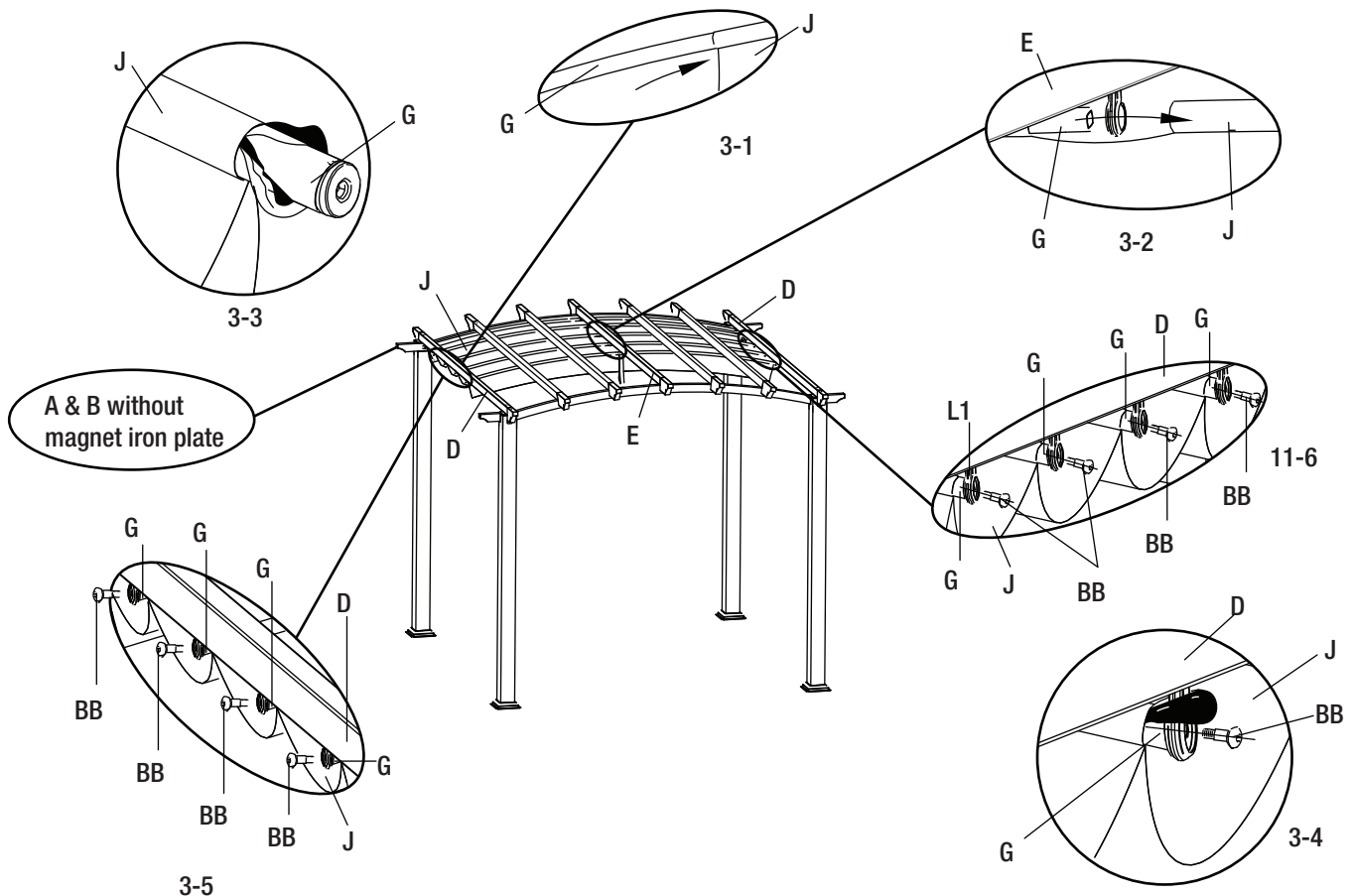

Assembly (continued)

4 Installing the protective cover

- Attach the protective cover (I) to the side top bars (D) and the center lengthways bar (E) using M6x15 combination bolts (AA).



NOTE: Fully tighten all the bolts using the hex wrench (FF).

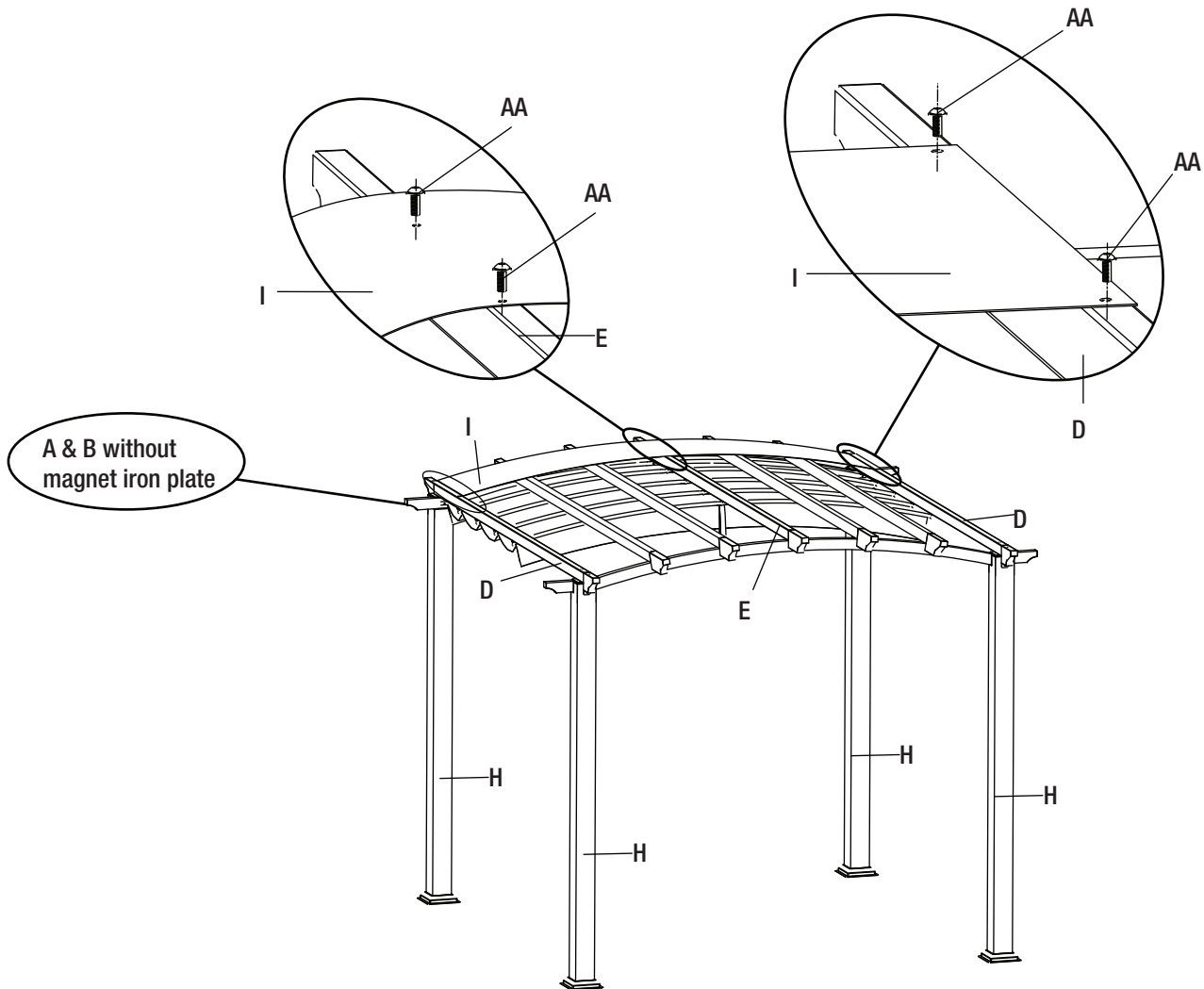

Care and Cleaning

- For best results, clean the canopy with a damp cloth, and dry the frames thoroughly. This will help prevent mildew by removing dirt particles that may accumulate.
- Do not clean with abrasive materials, bleach, or solvents.
- Store the canopy in a dry, sheltered place when not in use.
- Keep the canopy away from fire, extreme heat, freezing conditions, and inclement weather such as rain, hail, sleet, snow, or wind.

HAMPTON BAY®

Questions, problems, missing parts? Before returning to the store,
call Hampton Bay Customer Service.
8 a.m. - 7 p.m., EST, Monday - Friday, 9 a.m. - 6 p.m., EST, Saturday

1-855-HD-HAMPTON

HAMPTONBAY.COM

Retain this manual for future use.