

# Trex® Outdoor Furniture™

Assembly Instructions  
Model: TXC2280

- \_\_\_ (2) Sideframe
- \_\_\_ (1) Seat
- \_\_\_ (1) Back
- \_\_\_ (2) Stretcher - short
- \_\_\_ (2) Stretcher - long
- \_\_\_ (2) Front leg
- \_\_\_ (1) Metal brace
- \_\_\_ (1) Hardware pack

## Step 1

Attach front legs to seat assembly using (4) 1 3/4" bolts.

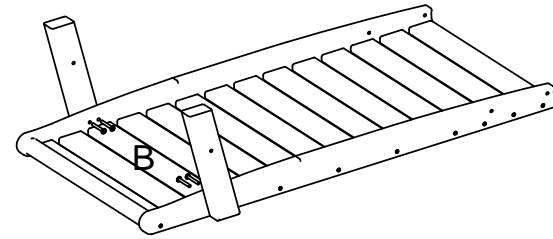

## Step 2

Attach arm assemblies to the seat assembly and the back assembly using (6) 1 3/4" bolts.

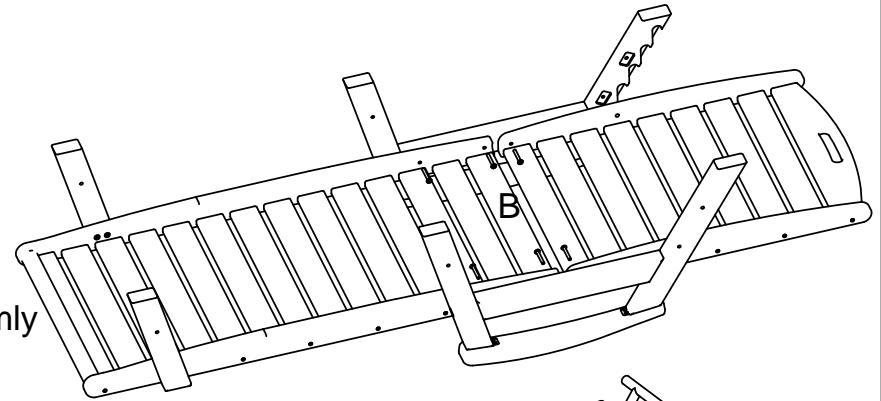

## Step 3

Attach metal brace to the seat using (2) 1 1/2" bolts.

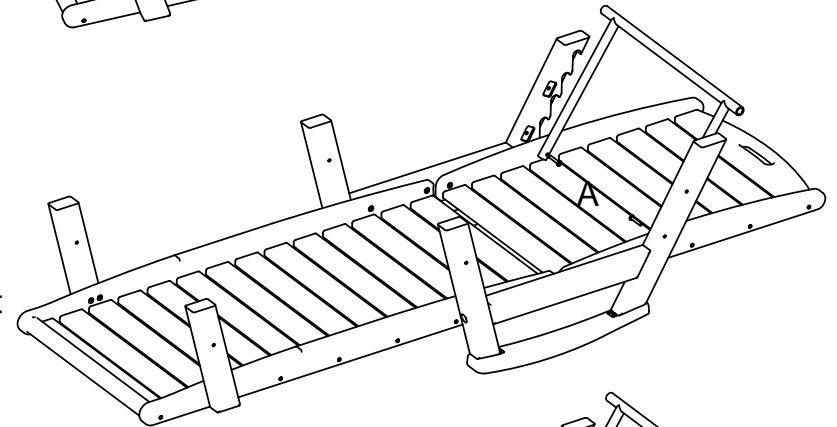

## Step 4

Attach stretchers to the legs using (8) 2 1/4" bolts.

\*note\*  
there are long and short stretchers

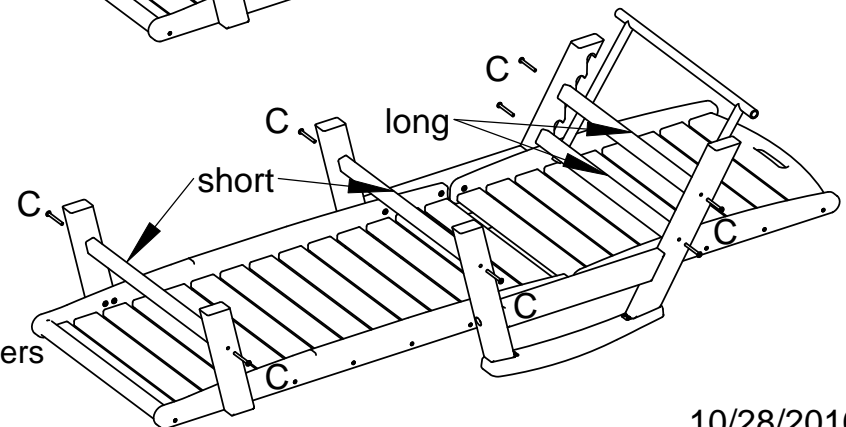

### TOOLS NEEDED

4mm HEX KEY: INCLUDED

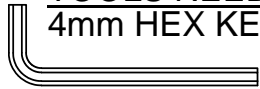

Qty.	Description
2	A-1 1/2" Chair Bolt
10	B - 1 3/4" Chair Bolt
8	C - 2 1/4" Chair Bolt

# TREX OUTDOOR FURNITURE WARRANTY

Poly-Wood, Inc., (hereinafter "Poly-Wood"), the licensee of Trex® Outdoor Furniture™, warrants to the original purchaser ("Purchaser") that, for a period of five (5) years of residential use and one (1) year for commercial use from the date of original purchase, under normal use and service conditions, Trex Outdoor Furniture products (other than the cushion, which is covered by the warranty set forth below) shall be free from material defects in workmanship and materials, and shall not splinter, crack, chip, peel, rot, or suffer structural damage from insect infestation. If a defect occurs within the warranty period, Purchaser shall notify dealer originally purchased from and is responsible for providing proof of purchase and a written description of the defect. Once documentation has been received and evaluated, Poly-Wood's sole responsibility shall be, at its option, to repair or replace defective component, to repair or replace defective furniture, or authorize repairs by a third party, and the Purchaser will be notified of the solution. If product is not returned within 60 days of date of original purchase, Purchaser is responsible for all shipping charges that may apply.

This warranty shall not cover and Poly-Wood shall not be responsible for costs and expenses associated with labor, transportation or assembly. This warranty does not apply to the hardware used to assemble the furniture.

Poly-Wood does not warrant against and is not responsible for, and no implied warranty shall be deemed to cover, any condition attributable to: (1) improper assembly and/or failure to abide by the assembly guidelines for Trex Outdoor Furniture, including any lack of performance or improper performance by the dealer or assembler; (2) damage resulting from the application of paint, varnish, or other coating or chemical not approved by Poly-Wood; (3) any lack of compatibility between Trex Outdoor Furniture products and any other product not manufactured by Poly-Wood that causes damage to or failure of product; (4) color or pattern variance between any new replacement section or pieces and other sections or pieces, with Poly-Wood reserving the right to discontinue or modify any product line or color without notifying the Purchaser (if the original product is not available Poly-Wood retains the right to choose to provide replacement material of equal value or quality); (5) fading, color change, or color match on any variegated profiles or accessories; (6) assembly of hardware, accessory items or defects caused by their assembly; (7) any act of God (such as fire, flooding, hurricane, earthquake, tornado, lightning, ice, etc.), environmental condition (such as air pollution, mold, mildew, etc.), staining from foreign substances (such as dirt, grease, oil, etc.), or normal weathering (defined as exposure to sunlight, weather and atmosphere which may cause any colored surface to gradually fade, darken, chalk, or accumulate dirt or stains); (8) improper handling, storage, unauthorized repairs or alterations, abuse or neglect of Trex Outdoor Furniture products by Purchaser or third parties; or (9) ordinary wear and tear.

**Trex Outdoor Furniture Cushion Warranty:** Poly-Wood warranties to the original purchaser for a period of thirty (30) days from date of purchase. This warranty covers any defects in the manufacturing and workmanship of the cushion. This warranty does not apply to normal wear and tear effects on the cushions, which are received by regular use of the cushions. Neither does it cover damage due to unauthorized repairs or alterations, negligence, misuse or abuse, improper assembly and acts of God.

No person or entity is authorized by Poly-Wood to make and Poly-Wood shall not be bound by any statement or representation as to the quality or performance of Trex Outdoor Furniture products other than as contained in this warranty. This warranty may not be altered or amended except in a written instrument signed by Poly-Wood and Purchaser.

UNDER NO CIRCUMSTANCES WILL POLY-WOOD BE LIABLE FOR SPECIAL, INCIDENTAL OR CONSEQUENTIAL DAMAGES, WHETHER SUCH DAMAGES ARE SOUGHT IN CONTRACT, IN TORT (INCLUDING BUT NOT LIMITED TO NEGLIGENCE AND STRICT LIABILITY) OR OTHERWISE, AND POLY-WOOD'S LIABILITY WITH RESPECT TO DEFECTIVE PRODUCTS SHALL IN NO EVENT EXCEED THE REPLACEMENT OF SUCH PRODUCTS OR RETURN OF THE PURCHASE PRICE, AS DESCRIBED ABOVE.

Some states do not allow the exclusions or limitations of incidental or consequential damages, so the above limitations or exclusions may not apply to you. This warranty gives you specific legal rights, and you may also have other rights that vary from state to state.

This warranty shall only be applicable and enforceable in the United States of America and Canada.