



ACCESS SYSTEMS

PHOTOELECTRIC DUAL BEAM DETECTOR



Owners Manual
R4222

The GTO Access Systems Photoelectric Dual Beam Detector uses dual beam and through-beam technology to reduce false detections when detecting obstructions. When the beams detect the presence of a moving object, the detection will cause the gate(s) to stop and reverse to the fully open position. As long as the beam is obstructed the gate(s) will remain open. **Not compatible with solar powered gate operators.**

For use with all GTO Access Systems and Mighty Mule gate operators.

PARTS DESCRIPTION

COVER

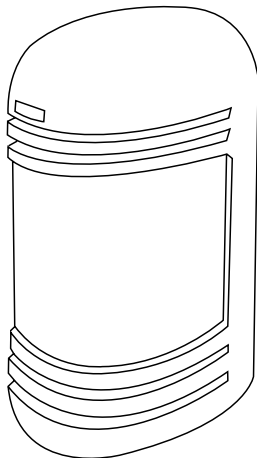

INTERNAL VIEW OF RECEIVER

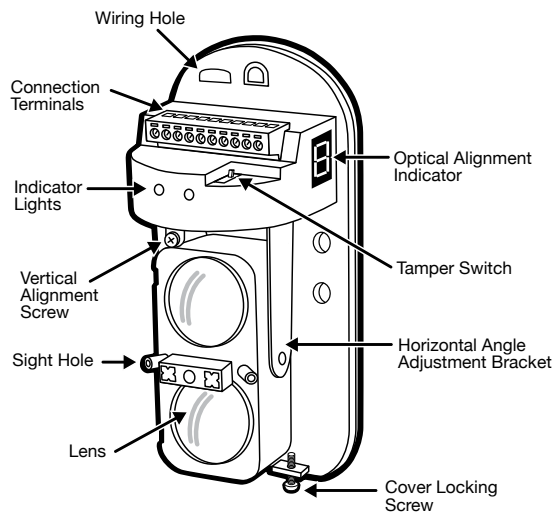

For more information on GTO's full line of automatic gate openers and access controls visit our website at www.gtoaccess.com

GTO Access Systems • 3121 Hartsfield Road • Tallahassee, Florida 32303 • (800) 543-4283 • www.gtoaccess.com
Technical Service (800) 543-1236

Installation Overview

Diagram illustrates correct placement of photo beams in relation to the gate.

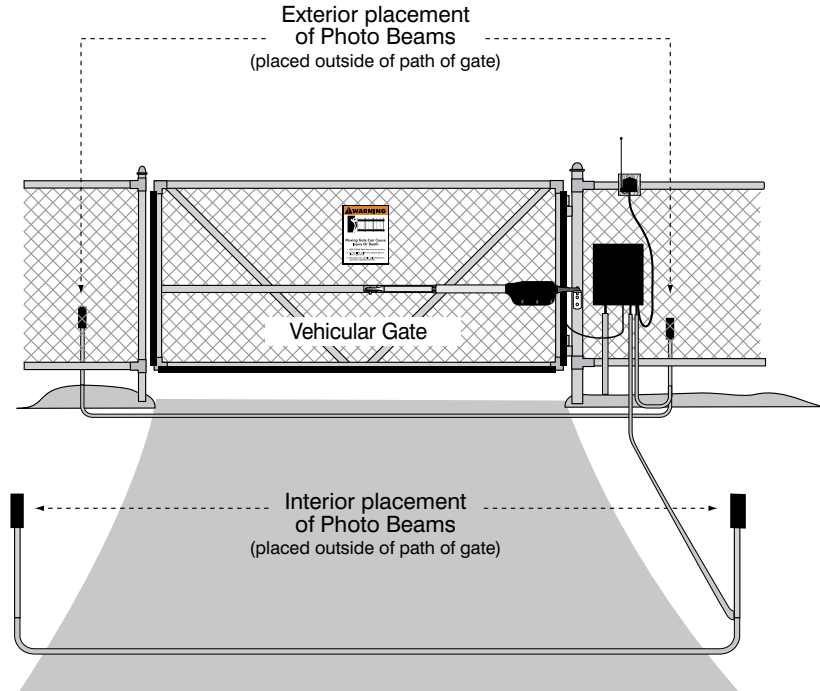

Mounting Cautions

Be sure that the optical axis is never obstructed. (The optical axis is both the vertical and horizontal range of detection, or beam, between the transmitter and receiver)

Do not mount the detector in the following conditions:

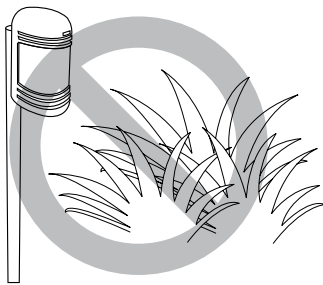

Where obstructions (plants, fences, etc.) are between the receiver and the sender.



Where the mounting surface is unstable.

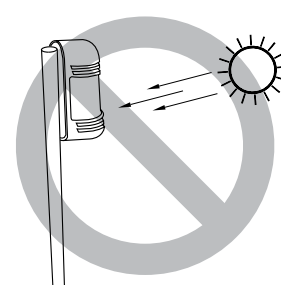

Where sunlight and headlights shine directly into the front of the receiver.

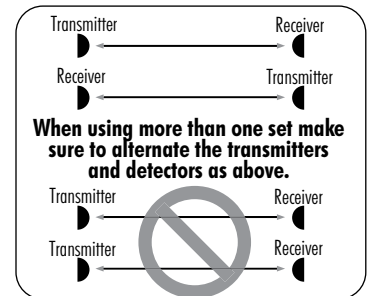
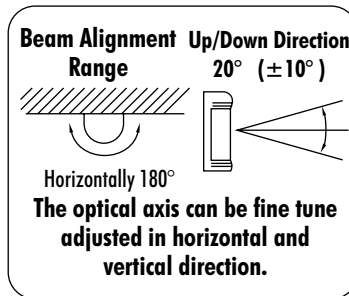
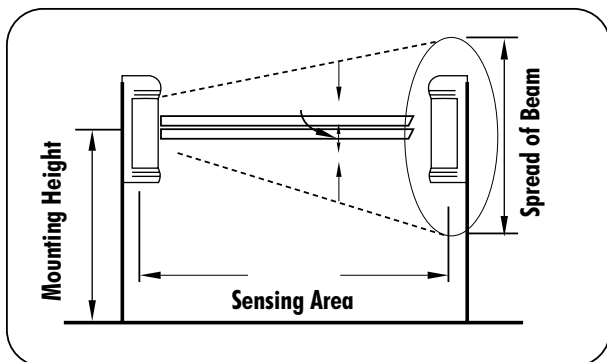

Wall Mounting

1. Remove Photo Beam cover by loosening the cover holding screw, but **DO NOT REMOVE THE SCREW ALL THE WAY.**

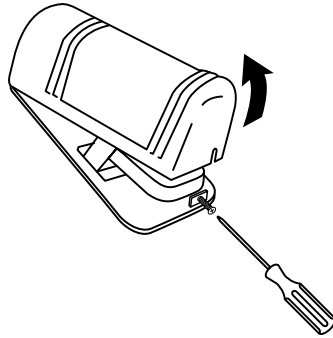

2. Pull the wire through the wiring hole at the top of the unit, from back to front.

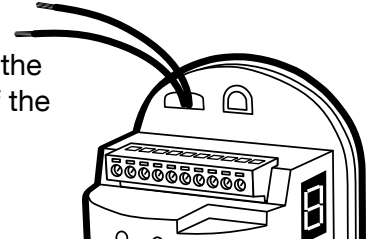

3. Remove the rubber knockout and use the screw holes to mount the unit.

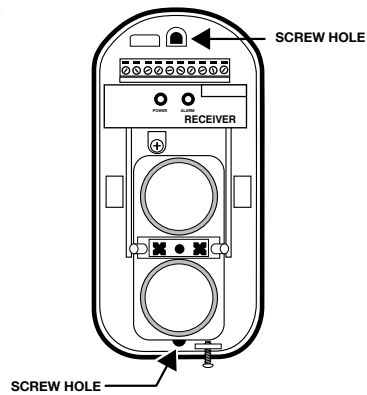

4. Mount the Photo Beam on the wall while running the wire into the wiring location in the wall.

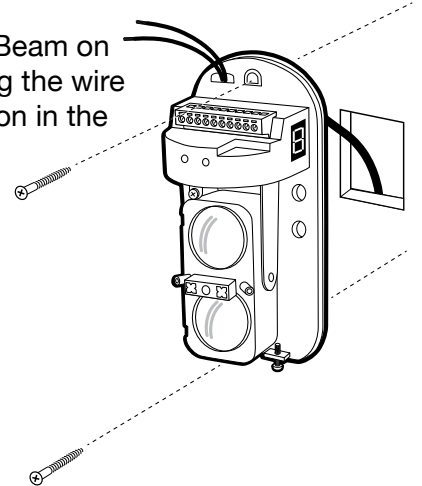

Pole Mounting

1. Remove the Photo Beam cover (as shown in step 1 above).
2. Feed the wire through the mounting pole.
3. Using the Mounting Plate and Bracket secure the Photo Beam to the mounting pole.

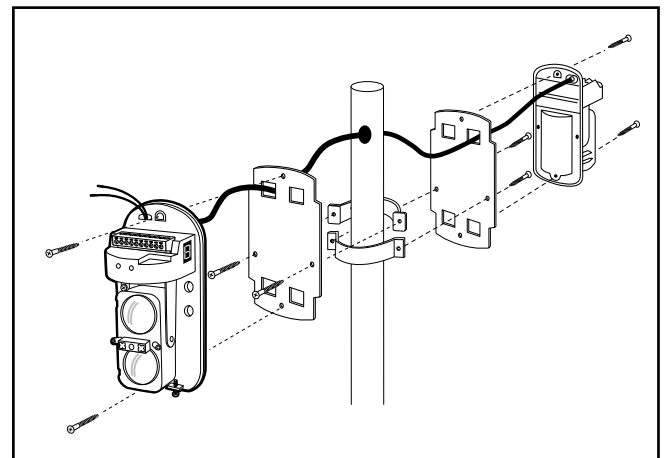
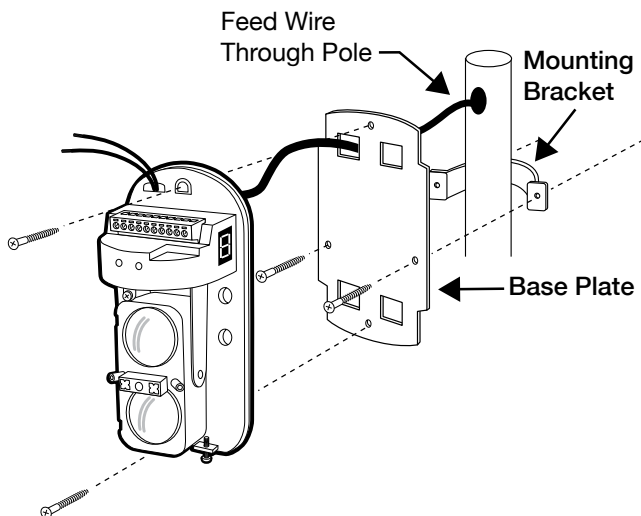

Back to Back Installation
(Refer to the figure above)

Connecting Photo Beams to GTO Access Systems and Mighty Mule Control Boards

IMPORTANT: DO NOT use Photo Beams on systems charged with solar panels.

Make sure the power switch to the opener is turned off before connecting safety device wiring to the terminal blocks. Unplugging the transformer does not turn power to the opener OFF.

Wiring Precautions

- Wire with 16awg minimum (RB509)
- 300 ft (91.4m) max length
- Be sure to capture the wire ends under the wire clamp plates.
- Avoid frayed ends on wires that might produce a short circuit.
- Be careful not to over tighten the screws as this may strip the threads in the plastic

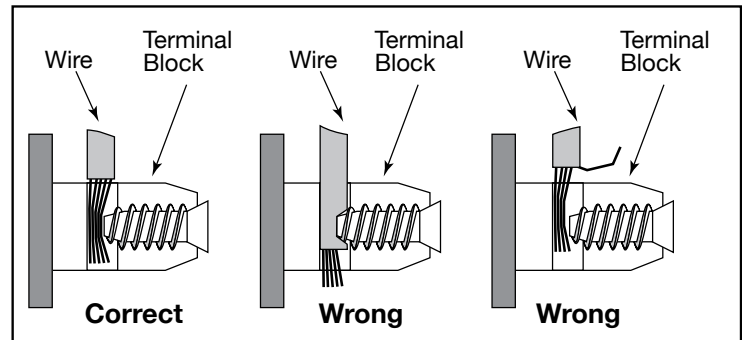

Terminal Strip Identification

These diagrams represent the terminal strips on the receiver and transmitter and can be used for reference for connections.

<p>RECEIVER Wiring Terminals</p> <p>① ② Power input ③ Common ④ Normally closed ⑤ Normally open ⑥ ⑦ Testing beam alignment. Should read 4vDV (+ or - 10%) after beam alignment. ⑧ Heater – not used nor available. ⑨ ⑩ Cover tamper switch. Cover switch is normally closed and opens when cover is removed. These contacts are not used and not necessary for gate opener applications.</p>	<p>TRANSMITTER Wiring Terminals</p> <p>① ② Power input ③ ④ Heater – not used nor available. ⑤ ⑥ Cover tamper switch. Cover switch is normally closed and opens when cover is removed. These contacts are not used and not necessary for gate opener applications.</p>
--	--

Wiring the Photo Beams to GTO Access Systems and Mighty Mule Gen 3 (blue) or green Gate Opener Control Boards.

(models listed below)

Connections for
**GTO Access Systems 2000XL,
 3000XLS, 4000XLS; Mighty Mule FM500
 and FM600 Control Boards**

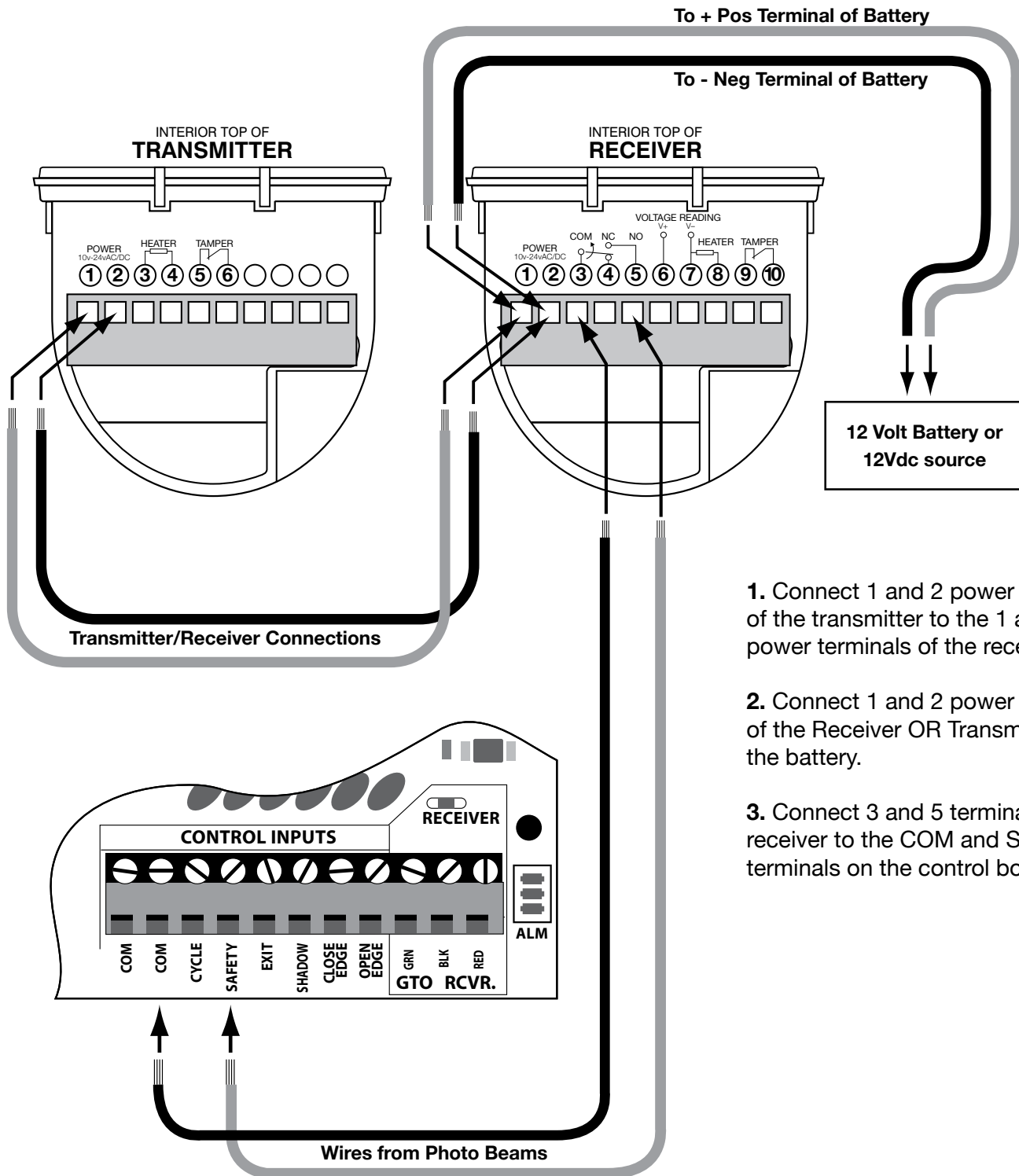

1. Connect 1 and 2 power terminals of the transmitter to the 1 and 2 power terminals of the receiver.
2. Connect 1 and 2 power terminals of the Receiver OR Transmitter to the battery.
3. Connect 3 and 5 terminals of the receiver to the COM and SAFETY terminals on the control board.

Wiring the Photo Beams to GTO Access Systems SW2000XLS and Mighty Mule FM362 and FM402 Gate Opener Control Boards.

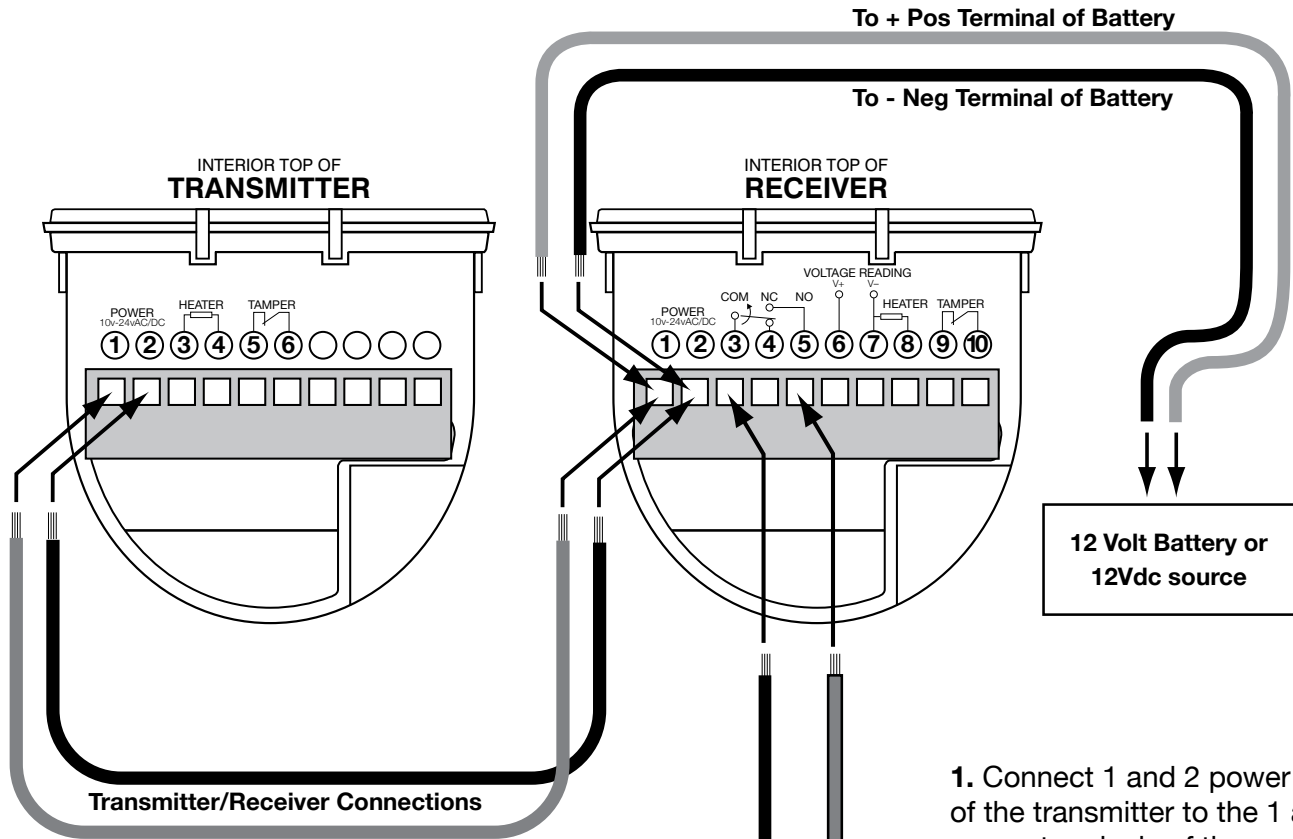

1. Connect 1 and 2 power terminals of the transmitter to the 1 and 2 power terminals of the receiver.
2. Connect 1 and 2 power terminals of the Receiver OR Transmitter to the battery.
3. Connect 3 and 5 terminals of the receiver to the COM and SAFETY terminals on the control board.

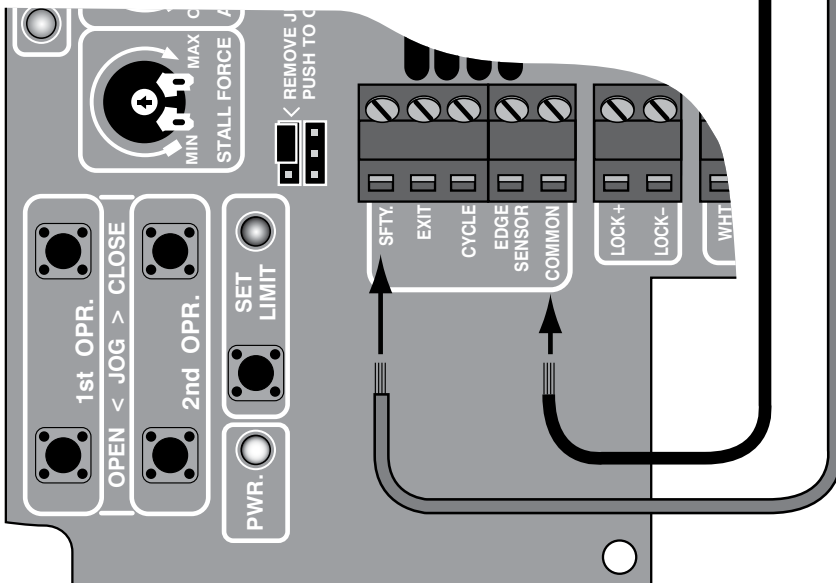

Wiring the Photo Beams to Mighty Mule FM350 Gate Opener Control Board.

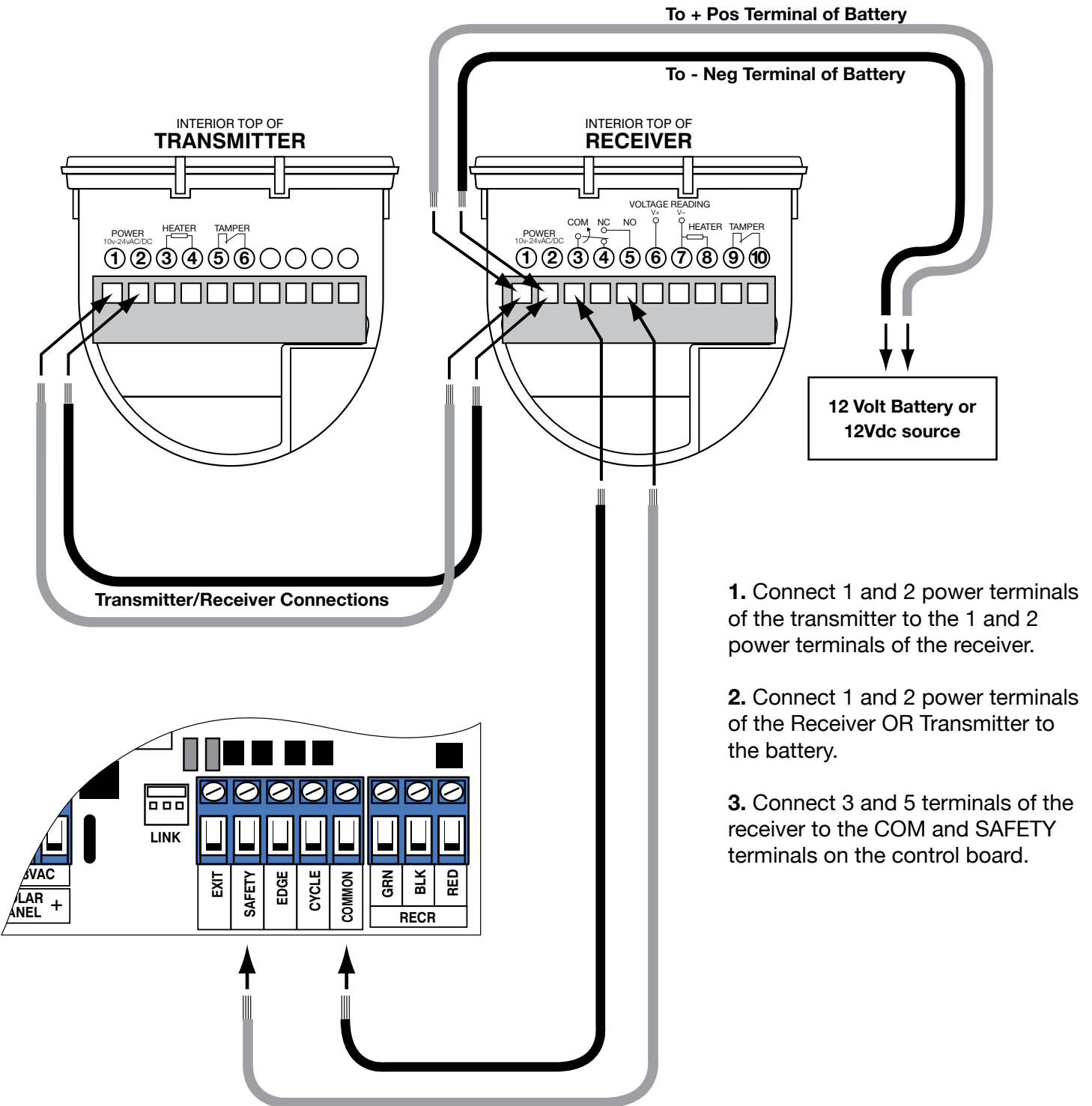

Wiring the Photo Beams to GTO Access Systems GP-SL050, GP-SW050, GP-SL100 and GP-SW100 Gate Opener Control Boards.

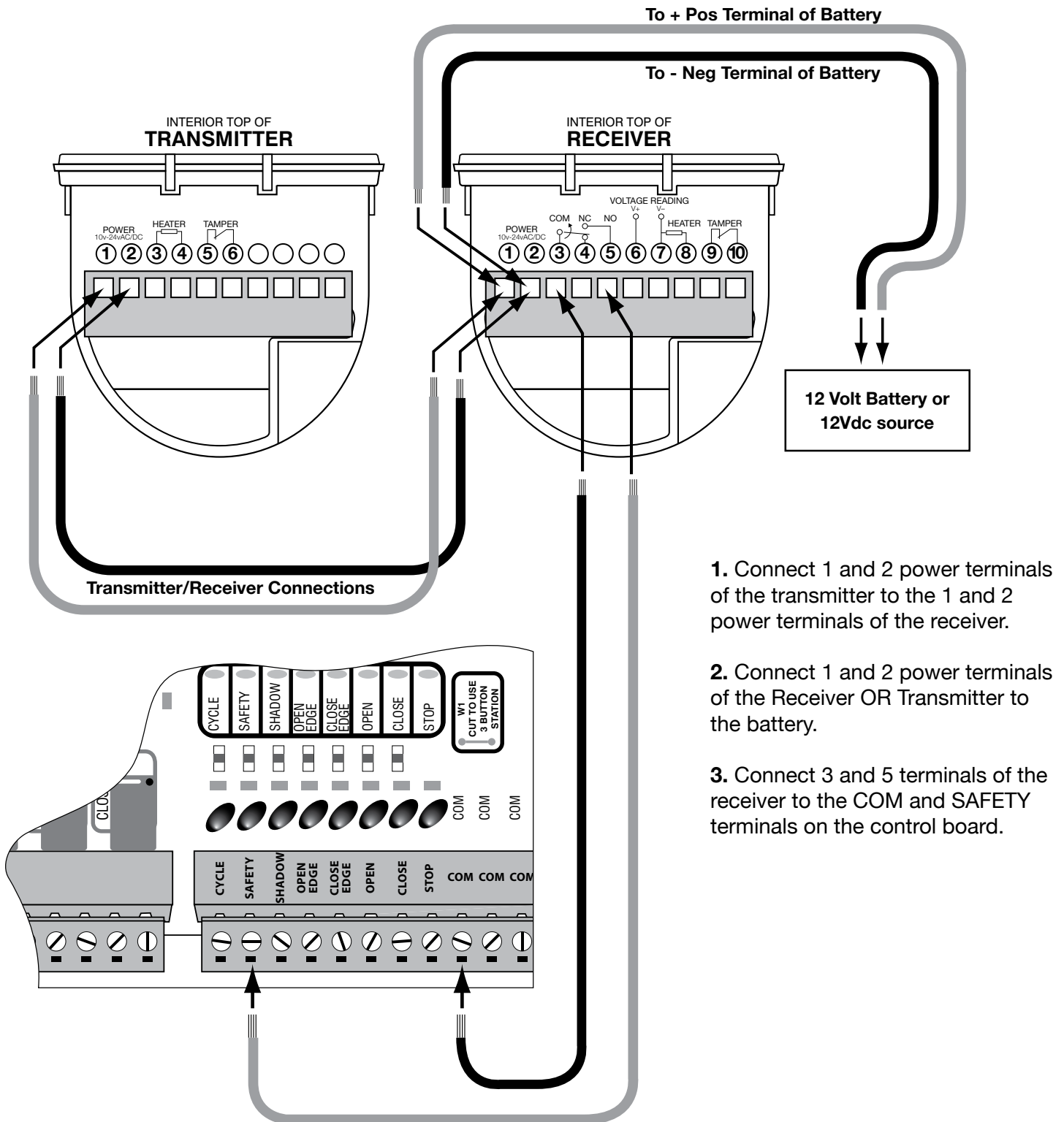

1. Connect 1 and 2 power terminals of the transmitter to the 1 and 2 power terminals of the receiver.
2. Connect 1 and 2 power terminals of the Receiver OR Transmitter to the battery.
3. Connect 3 and 5 terminals of the receiver to the COM and SAFETY terminals on the control board.

Wiring the Photo Beams to Mighty Mule 200 Gate Opener Control Board.

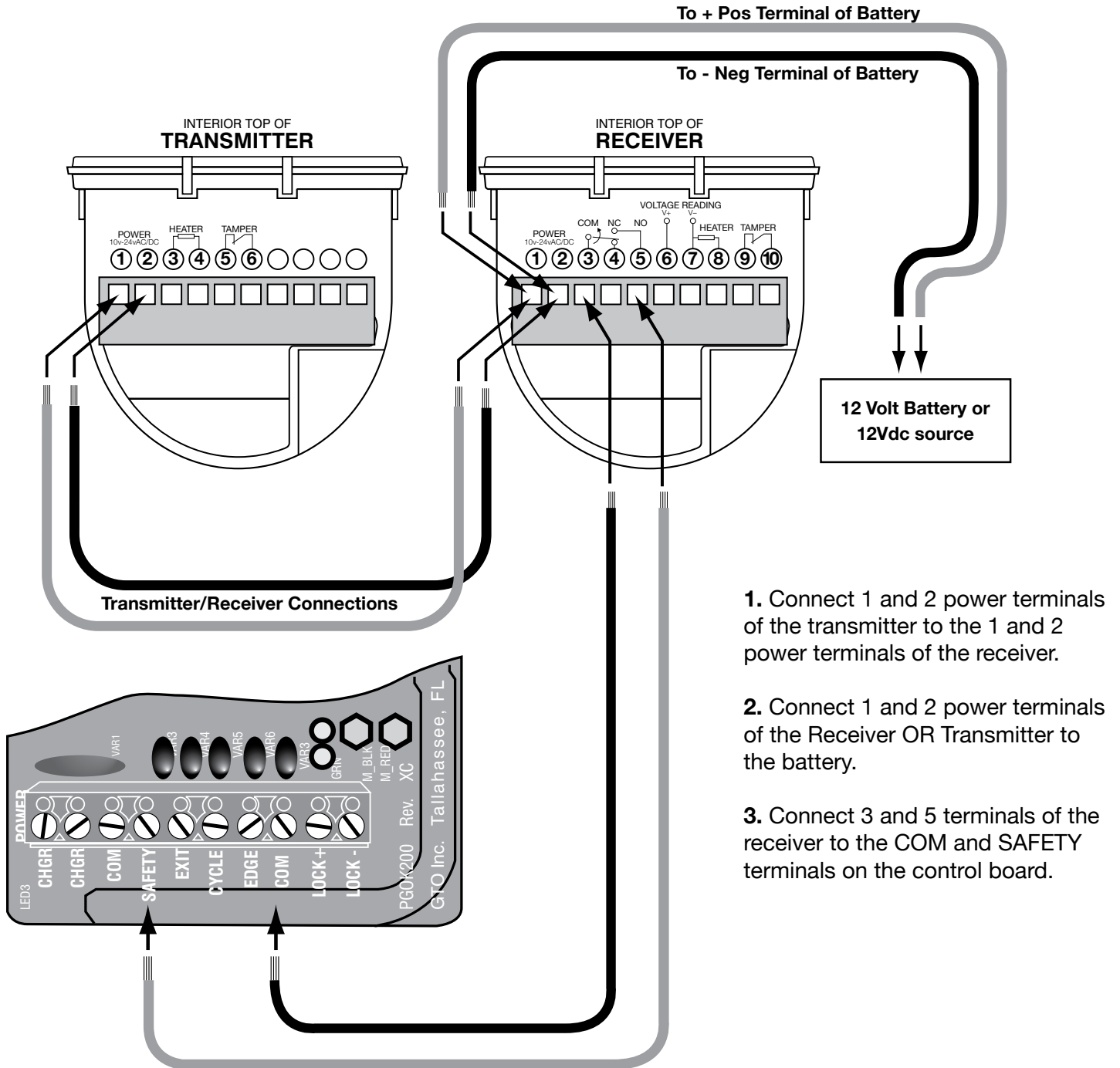

DIP Switch Settings

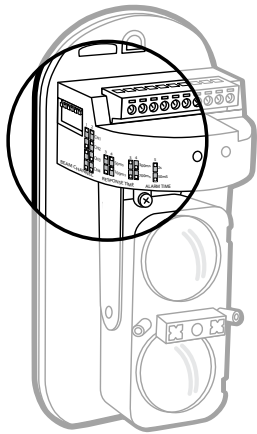

Receiver DIP Switches

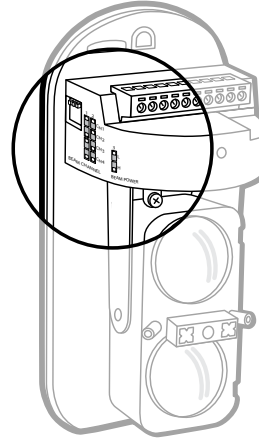
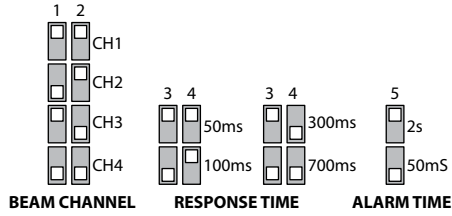
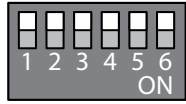

Transmitter DIP Switches

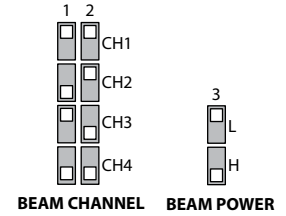
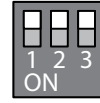

Receiver DIP Switch Settings:

- 1&2 – Different frequency settings for multiple beams in close proximity. Receiver and Transmitter must have 1&2 set the same.
- 3&4 – For adjusting RESPONSE TIME of beam. In locations where flying debris or birds are an issue, a longer response time may be necessary. The recommend FACTORY setting is 3&4 ON.
- 5 — For adjusting time unit remains in ALARM state.
- 6 — No function.

Transmitter DIP Switch Settings:

- 1&2 – Set the same as Receiver
- 3 — Beam Power – for recommended application DIP 3 must remain on “L” low.

Beam Alignment

Adjusting Optical Axis with the Viewfinder

With the POWER connected and the RECEIVER and TRANSMITTER covers removed, make sure DIP switch 1 & 2 are set the same on the RECEIVER and TRANSMITTER.

Adjust the horizontal pivot and the vertical adjustment screw. Look through the viewfinder on either side and adjust to put the opposite sensor in the middle of the cross-hairs in the view finder.

Adjust the alignment until the LED display on the receiver reads between 5 to 9 volts additionally the voltage between terminals 6 & 7 on the Receiver should be 4 VDC ($\pm 10\%$).

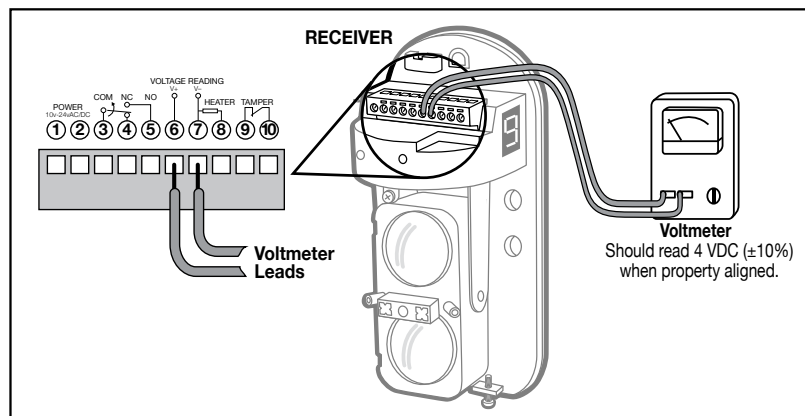
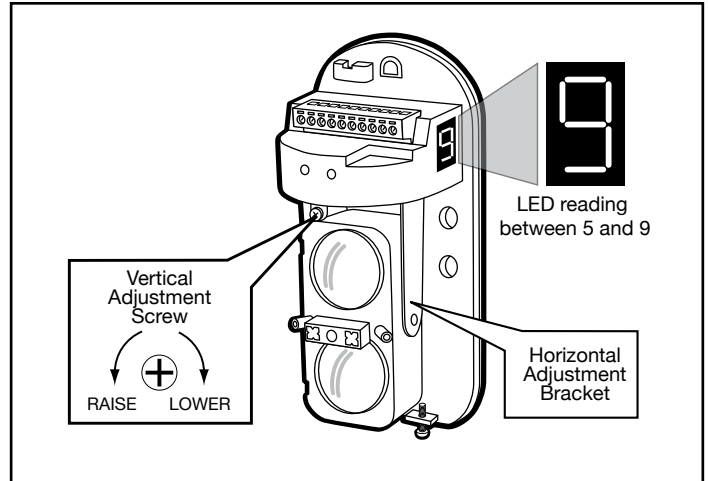
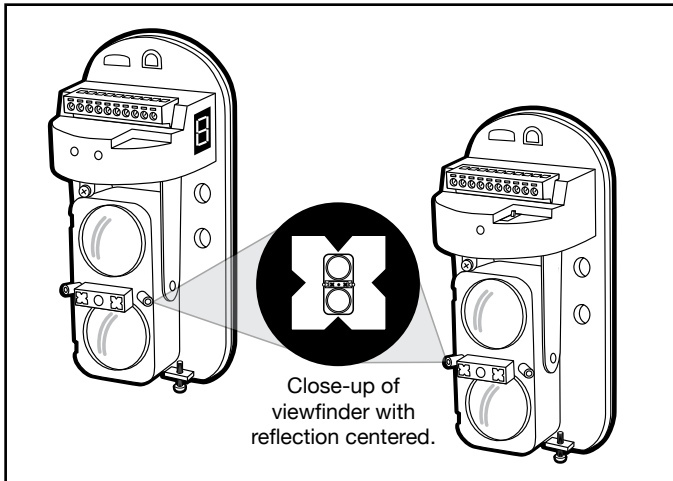

Beam Response Time Adjustment

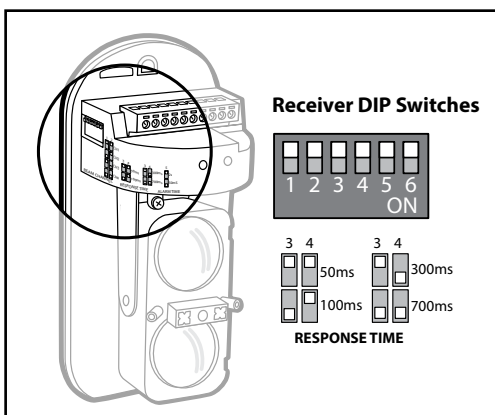

Adjusts the amount of time between the beam being broken and the normally open relay closing. Adjust the response time by adjusting DIP switches 3 & 4.

The factory setting is DIP 3 & 4 ON, to detect fast moving objects. This is the recommended setting for gate automation applications.

VERIFY CORRECT OPERATION

After installation, confirm correct operation by suitable walking tests. Refer to the appropriate LED indicators during the walking test and ensure the gate opener operates in the correct manner.

	Condition	Indication
Transmitter	Transmitting	Power LED is ON
Receiver	Beam Not Blocked	Power LED ON/Alarm LED OFF
	Beam Blocked	Power LED ON/Alarm LED is ON

TROUBLESHOOTING

Symptom	Possible Cause	Remedy
Transmitter POWER LED does not light.	Improper voltage supplied.	Check the power supply and wiring.
Receiver POWER LED do not light.	Improper voltage supplied.	Check the power supply and wiring.
Alarm LED does not light, even when beams are blocked.	<ol style="list-style-type: none"> 1. Beams reflect to the receiver by other objects. 2. Both beams are not blocked simultaneously. 3. Beam response time is too short. 	<ol style="list-style-type: none"> 1. Remove the reflecting object or change optical axis direction. 2. Block both beams. 3. Adjust Beam response time.
When beams are blocked, receiver LED lights are ON, but not alarm.	<ol style="list-style-type: none"> 1. Wiring is short circuited. 2. Wiring connection is not good. 	Check wiring and connection spot.
The alarm indication lamp of receiver is always on.	<ol style="list-style-type: none"> 1. Optical axis is not properly adjusted. 2. There are obstructions between the transmitter and the receiver. 3. The outer covers are dirty. 4. Wiring is short circuited. 	<ol style="list-style-type: none"> 1. Adjust the optical axis. 2. Remove the obstructions. 3. Clean with window cleaner and a soft cloth. 4. Repair wiring.
Intermittent Alarm (detection)	<ol style="list-style-type: none"> 1. Bad wiring. 2. Fluctuating power supply / voltage. 3. Intermittent blockage between the transmitter and the receiver. 4. The receiver or transmitter is unstable. 5. Blocked by other moving objects. 6. Beam response time incorrect for specific installation. 	<ol style="list-style-type: none"> 1. Check wiring. 2. Check the power supply. 3. Remove the obstruction or relocate. 4. Fix the mounting. 5. Adjust the optical axis. 6. Adjust interruption time or change installation position.

For online Technical Support visit the Online Troubleshooter Wizard 24 hrs/day 7 days/week at <http://support.gtoinc.com/support/troubleshooter.aspx> and open a Tech Ticket
 Technical Support Hours: MON - FRI 8:00AM - 7:00PM (ET) (800) 543-1236

SPECIFICATIONS

MODEL R4222		
Detection Method		Infrared pulsed beams
Range	Outdoor	131ft (40m)
	Indoor	252ft (80m)
Interruption Period		50ms, 100ms, 300ms, 700ms (4 steps)
Beam Frequency		4 Channel
Power Input		10V-24V DC/AC (12 VDC Recommended)
Current		90mA max
Minimum Alarm Period		2Sec or 50ms
Alarm Output		Form C relay (AC/DC 30V 0.5A max)
Tamper Switch		N.C. contact is open when cover is removed (transmitter and receiver)
Operating Temperature		-13°F (-25°C)~131°F (55°C)
Environment Humidity		95% max
Alignment Angle		Horizontal 180° (±90°), Vertical 290° (±10°)
Mounting		Wall or pole
Weight		2.2lbs (1000g) Both transmitter and receiver

For optimal efficiency, wipe the outer cover frequently with a soft, damp cloth.

Not compatible with Solar Panels.