

The logo features the word "Kraus" in a white, serif font with a registered trademark symbol (®) to the upper right. The letter "K" is stylized with three horizontal lines passing through its vertical stem. The letters "a", "u", and "s" also have horizontal lines passing through them, creating a sense of motion or water flow.

INSTALLATION MANUAL

Single Lever Pull-Out Kitchen Faucet

KPF-1602

Thank you for your purchase

We would like to take this opportunity to thank you for choosing Kraus. We hope that you are completely satisfied with your purchase, and enjoy it for years to come. If you have any questions, or require technical assistance, please contact us at 800.775.0703 and one of our representatives will be happy to help.

For more information about Kraus products, please visit:

www.kraususa.com

In order to activate your warranty and get faster access to customer support, please register your new Kraus product at:

www.kraususa.com/registration

Sincerely,

Kraus USA Customer Service

PRIOR TO INSTALLATION

- Make sure you have all necessary parts by checking the diagram and parts list. If any part is missing or damaged, please contact Kraus Customer Service at 800-775-0703 for a replacement
- Turn off the hot and cold water supply at the angle stops and turn on the old faucet to release any built up pressure. Remove existing faucet. Clean sink or countertop to remove any debris, plumber's putty, or silicone
- Place bucket under angle stops. Turn on to flush any debris prior to installing new plumbing. Shut off angle stops
- Pre-drilled hole size requirement: 1-3/8"
- Max countertop thickness without deck plate: 1-3/8"

For technical assistance or replacement parts, please contact Kraus Customer Service and one of our representatives will be happy to help:
Toll-Free: 800-775-0703 or Customerservice@kraususa.com

Tools Required

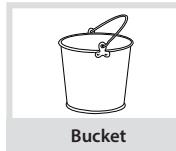
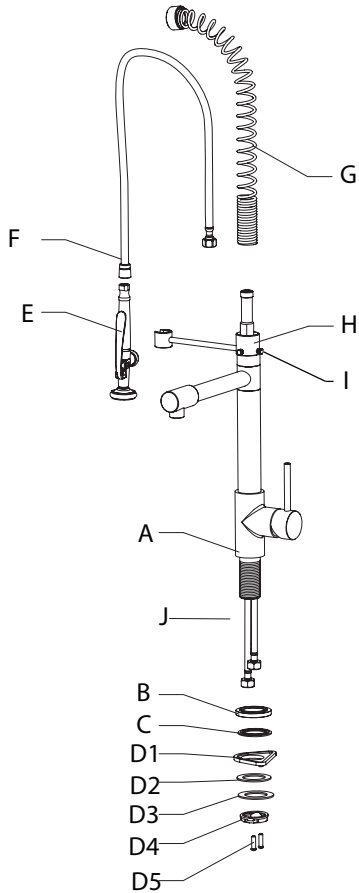
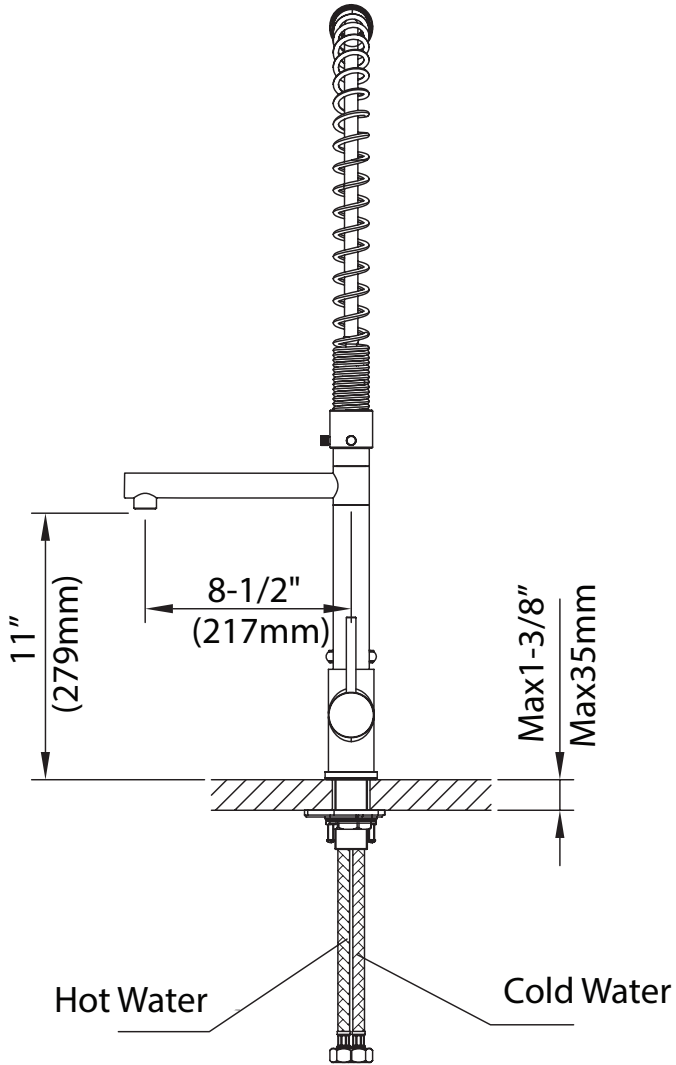

Diagram and Parts List



- | | |
|-------------------------------|----------------------------|
| A. Faucet Body | D4 Mounting Nut |
| B. Base | D5 Mounting Screws |
| C. Base O-Ring | E. Spray Head |
| D. Mounting Hardware Assembly | F. Spray Hose |
| D1 Plastic Washer – Optional | G. Spring |
| (Top Mount Sinks Only) | H. Sprayer Holder |
| D2 Rubber Washer | I. Thumb Screws |
| D3 Metal Washer | J. Hot and Cold Waterlines |

Faucet Dimensions



Faucet Dimensions

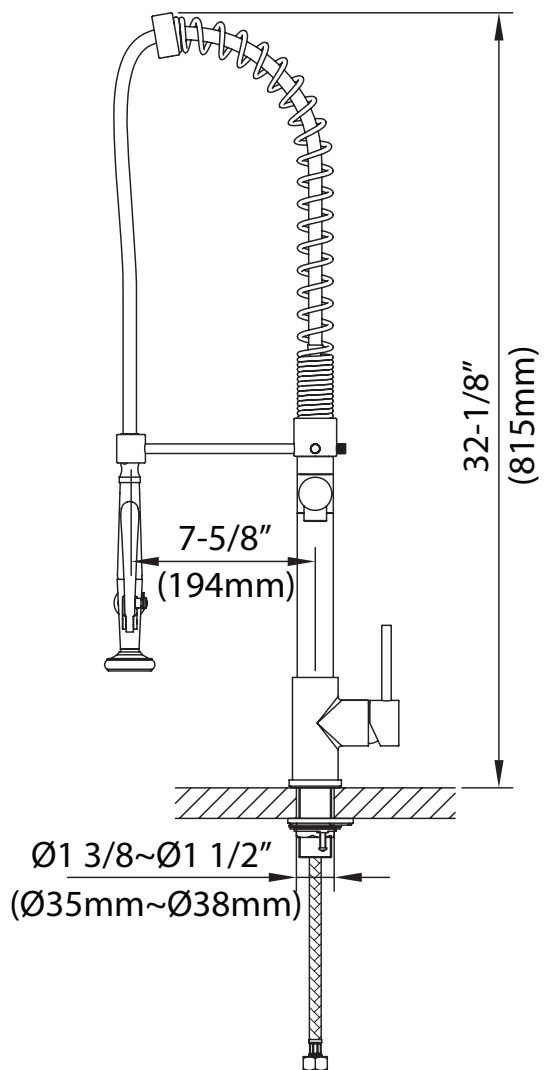

Faucet Installation Procedures

Installation Method 1

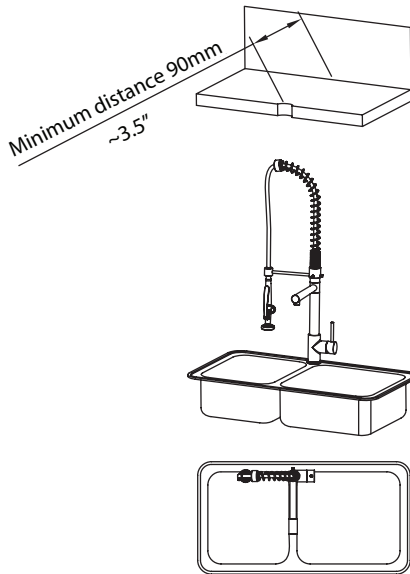

The minimum distance between the faucet hole and the wall should be 3.5"

Installation Method 2 (optional)

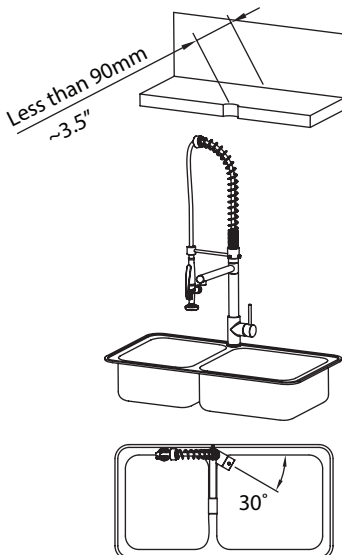

If the distance between the faucet hole and the wall is less than 3.5," position the faucet lever 30° to 90° off the wall to allow for full operation

Step 1

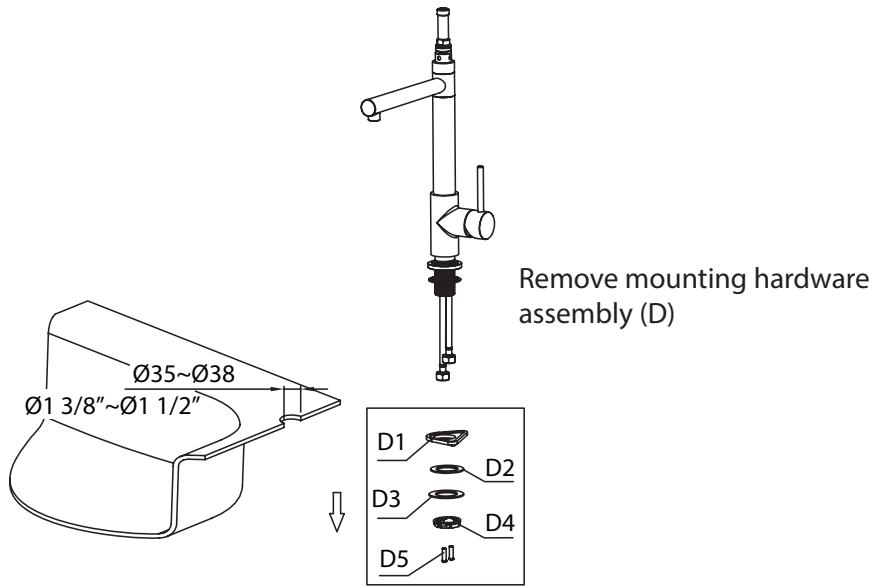

Step 2

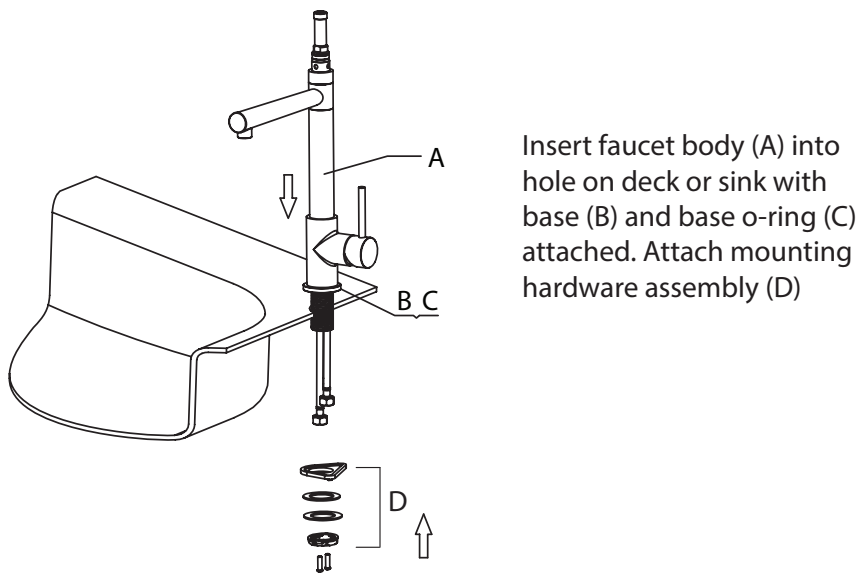

Step 3

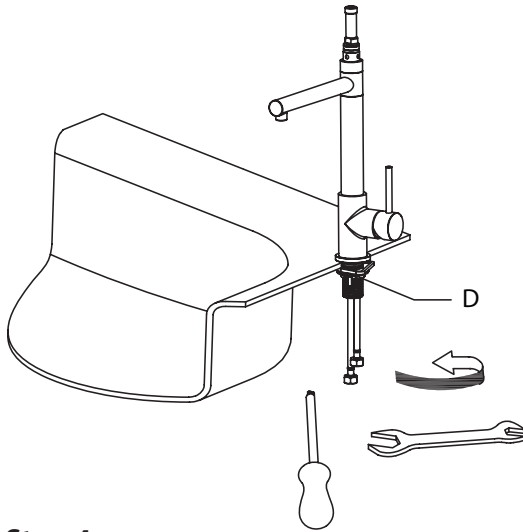

Adjust faucet body. Secure mounting hardware (D) with wrench and Phillips head screwdriver

Step 4

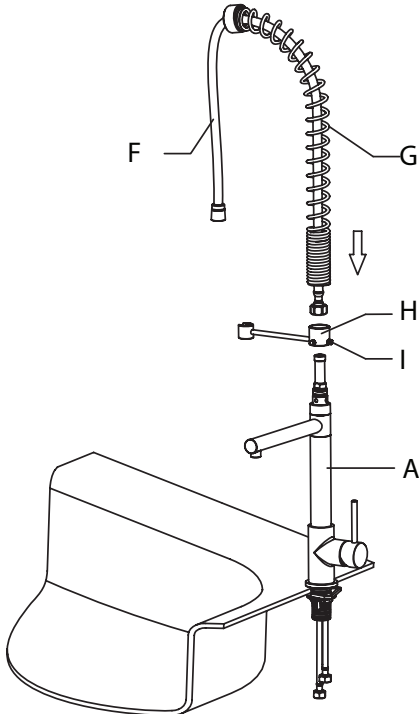

Attach sprayer holder (H) to faucet body (A). Hand-tighten thumb screws (I). Attach spray hose (F) with spring (G) attached to faucet body (A)

Step 5

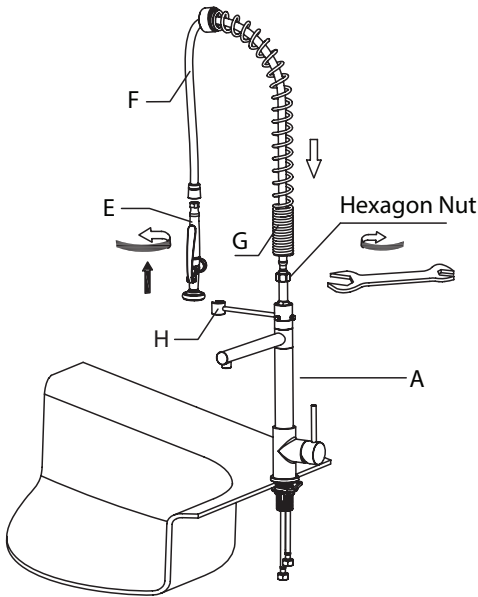

Secure spray hose (F) to faucet body (A). Insert spring (G) into sprayer holder (H). Connect spray head (E) to spray hose (F)

Step 6

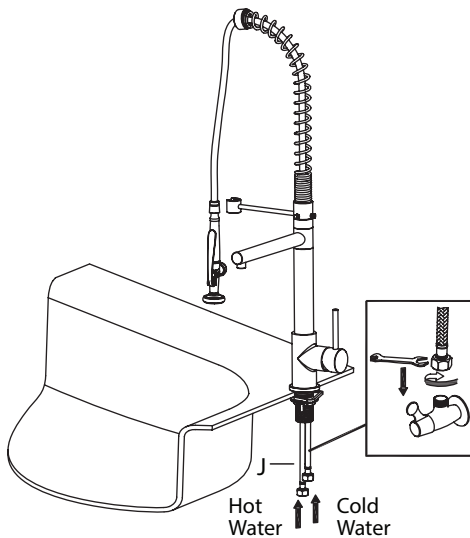

Connect and tighten waterlines (J) to angle stops. Turn on the angle stops and check for leaks **(DO NOT TURN FAUCET ON)**

Installer Tip

Remove spray head (E) and turn faucet on for 60 second to flush any debris

Usage

How to operate the handle:

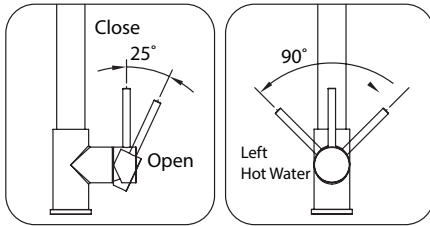

1. Pull the lever to the right to turn on the water. Push to the left to turn off
2. Pull the lever forward to increase hot water flow and push the lever back to increase the cold water flow

Sprayer:

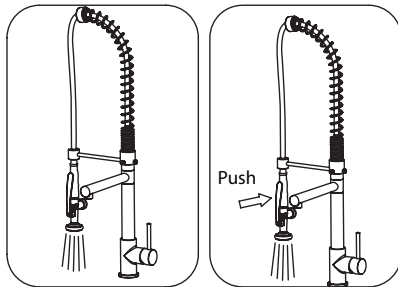

1. To activate sprayer, turn on water with lever and squeeze sprayer

Replacement Parts

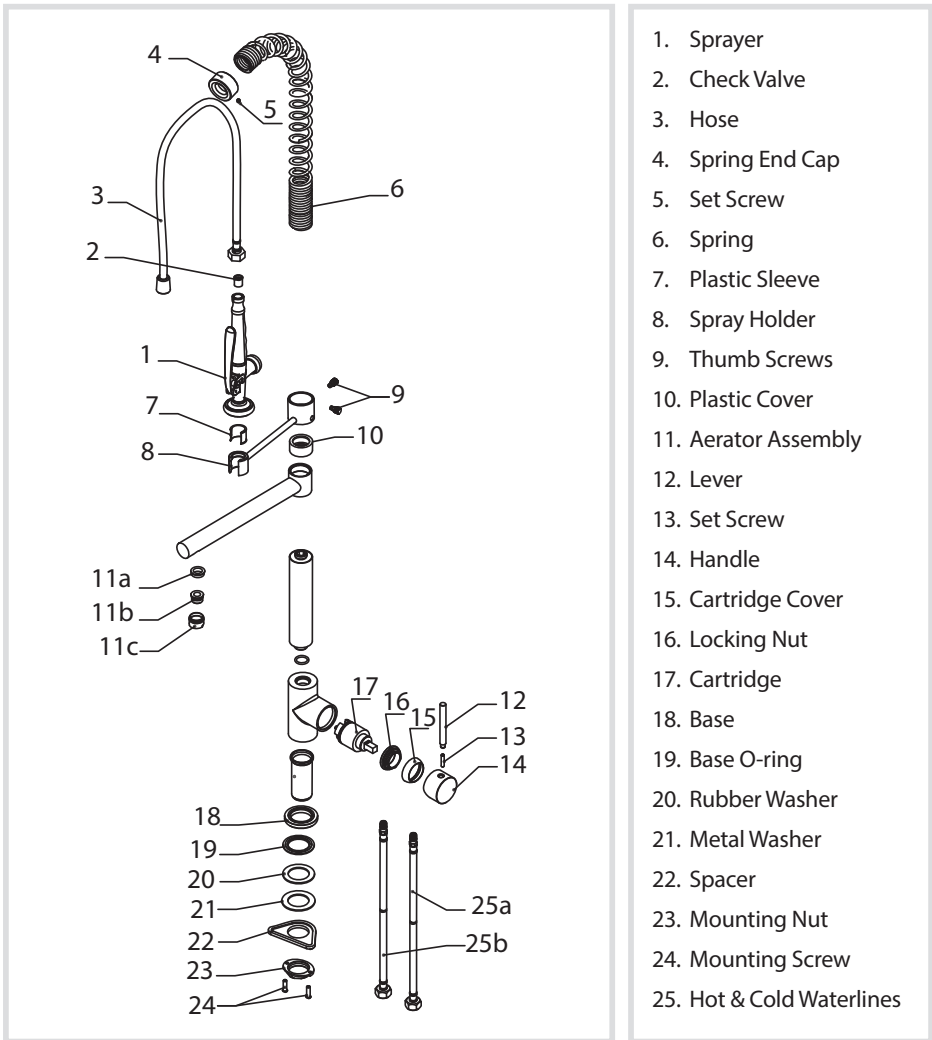

Trouble - Shooting

If you have followed the instructions carefully and your faucet still does not work properly, take the following corrective steps:

PROBLEM	CAUSE	ACTION
Leakage under the handle (14)	Locking nut (16) has come loose	Unscrew the lever (12) on the handle (14) by hand. Loosen set screw (13) with a hex wrench (2.5 mm). Remove the handle (14) and unscrew cartridge cover (15) by hand. Tighten locking nut (16) with an adjustable wrench
Aerator (11) drips or has inconsistent water flow pattern	Aerator (11) is dirty or not seated properly	Unscrew aerator (11) by hand and clean out debris
Water will not shut off completely	Cartridge may be defective	Unscrew the lever (12) on the handle (14) by hand. Loosen set screw (13) with a hex wrench (2.5 mm). Remove the handle (14) and unscrew cartridge cover (15) by hand. Unscrew the locking nut (16) with an adjustable wrench. Remove ceramic disc cartridge (17). Check for cracks
Leaking between hose (3) and faucet body or sprayer (1)	Hose (3) may be loose or washers are not seated correctly in the hose connections	Tighten the hexagon nut with a wrench and make sure the washers are seated correctly

Codes/Standards Applicable:



NSF/ANSI Standard 61 certified by IAPMO
NSF/ANSI Standard 372 certified by IAPMO



Meets ASME A112.18.1M/A112.18.1
1.75gpm 6.6L/min maximum

HELP LINE

Our customer service hours are Monday – Friday, 9am – 8pm EST.
Be sure to visit our website at www.kraususa.com

If you are a homeowner please contact a Kraus Customer Service Representative at:

Kraus USA, Inc.
12 Harbor Park Drive
Port Washington, NY 11050
Toll-free 800-775-0703
Customerservice@kraususa.com

If you are a plumbing contractor or trade professional please contact a Kraus Pro Representative at:

Kraus USA, Inc.
12 Harbor Park Drive
Port Washington, NY 11050
516-801-8955
Proservice@kraususa.com

If you are an Authorized Partner please contact a Partner Support Representative at:

Kraus USA, Inc.
12 Harbor Park Drive
Port Washington, NY 11050
516-801-8954
Partnersupport@kraususa.com

In requesting warranty service, please be ready to provide:

1. Proof of purchase.
2. A description of the problem.

Care & Maintenance

*To keep the product clean & shining, follow the steps below:

1. Rinse with clean water & dry with a soft cloth
2. Do not clean with soaps, acid, polish, abrasives, or harsh cleaners
3. Do not use cloth with a coarse surface
4. Unscrew the aerator and clean when necessary

*This installation manual is subject to change without further notice.



Download the Kraus Care & Maintenance Guide at:

<http://www.kraususa.com/maintenance>

Kräus[®]

www.kraususa.com

REGISTER YOUR PRODUCT TODAY

Receive Proof of Ownership
Access Customer Care & Installation Help
Get Exclusive Kraus Offers & Promotions



Scan to Register Online
or visit <http://www.kraususa.com/registration>

We're always looking for ways to improve.

Please take a moment to share your experience.
Visit <http://www.kraususa.com/review> to let us know what you think
about your new Kraus product.

Contact Us to Learn More
1.800.775.0703 / www.kraususa.com / customerservice@kraususa.com
Like & Follow KrausUSA

Download the Kraus Care & Maintenance Guide at:
<http://www.kraususa.com/maintenance>



Kräus[®]

www.kraususa.com