

BAR SINK STRAINER

Cat. No.
I5586



Features:

- ▶ Fits 2" bar sink drain
- ▶ Stainless steel spring loaded center post
- ▶ Seals water in sink
- ▶ Available in 7 Finishes

Finishes:

BS Brushed Stainless
CP Polished Chrome
BN Brushed Nickel
SS Stainless Steel

PN Polished Nickel
ORB Oil Rubbed Bronze
VB Venetian Bronze

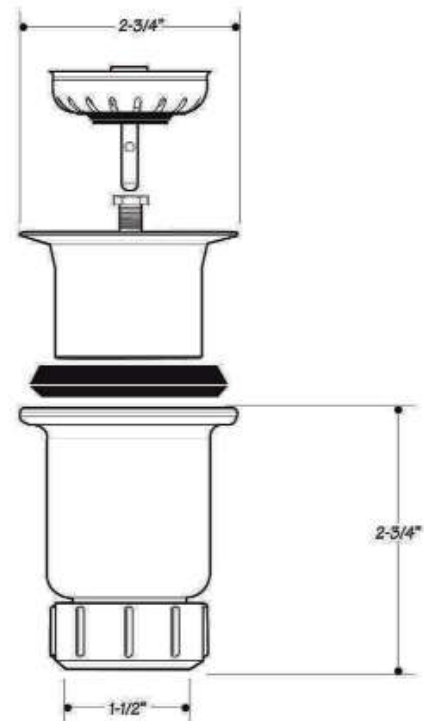

Dimensions and specifications subject to change without notice.