

**English**

# ASSEMBLY INSTRUCTIONS

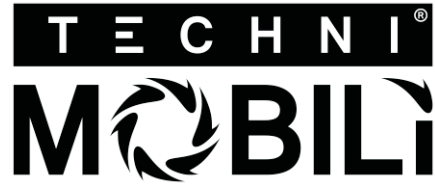

MODEL RTA - 4804L

Thanks for purchasing one of our products.  
Please read carefully the assembly instructions before the installation.  
Please save this manual for future reference.

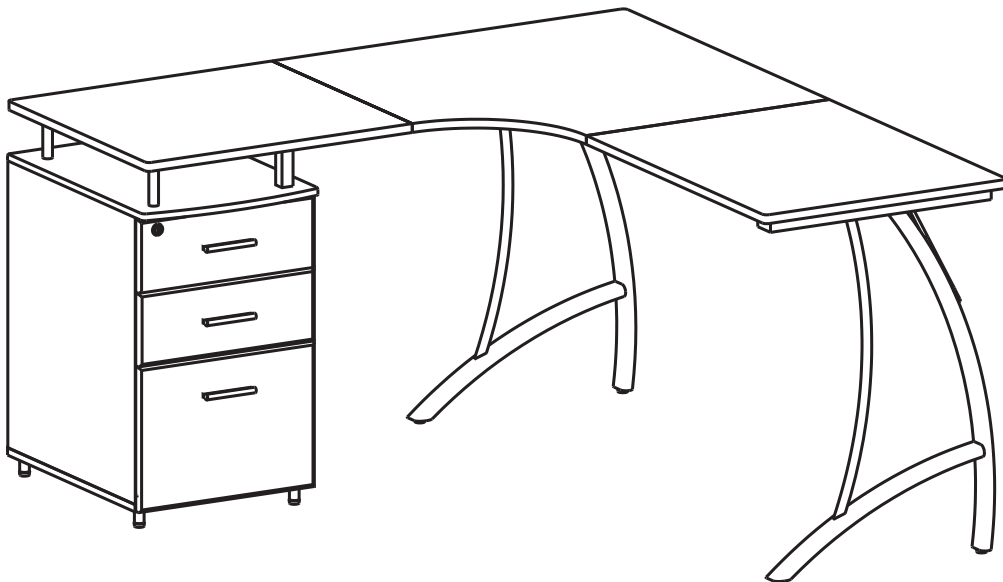

**MODEL RTA-4804L**



Spanish

## INSTRUCCIONES DE ENSAMBLAJE.

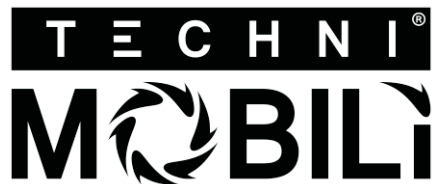

MODELO RTA - 4804L

Gracias por comprar uno de nuestros productos.

Por favor lea cuidadosamente las instrucciones de ensamblaje antes de instalar la unidad.

Por favor guarde este manual para referencias futuras.

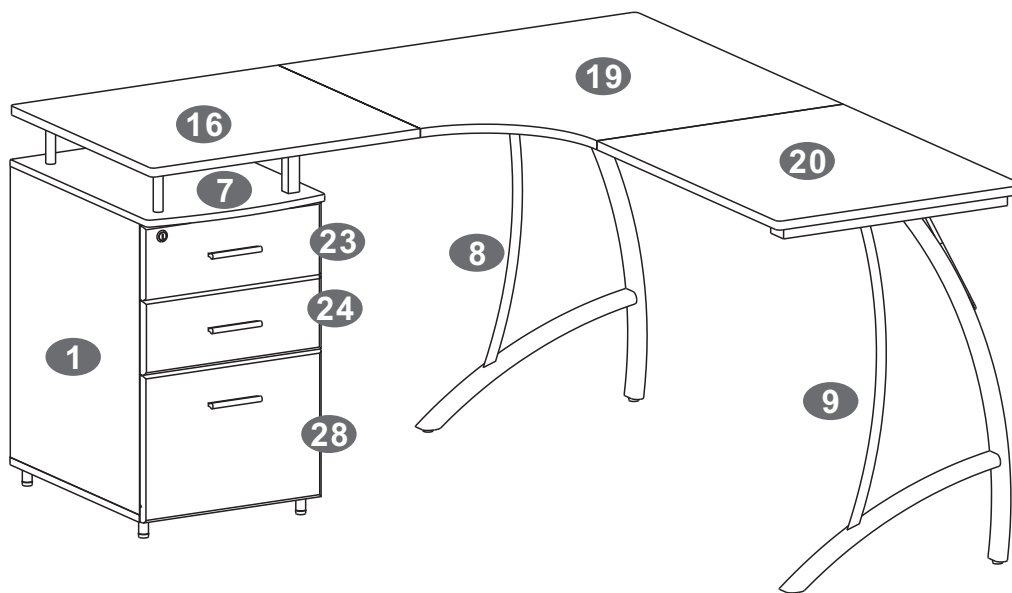

MODELO RTA-4804L



# RTA-4804L

## DIMENSIONS

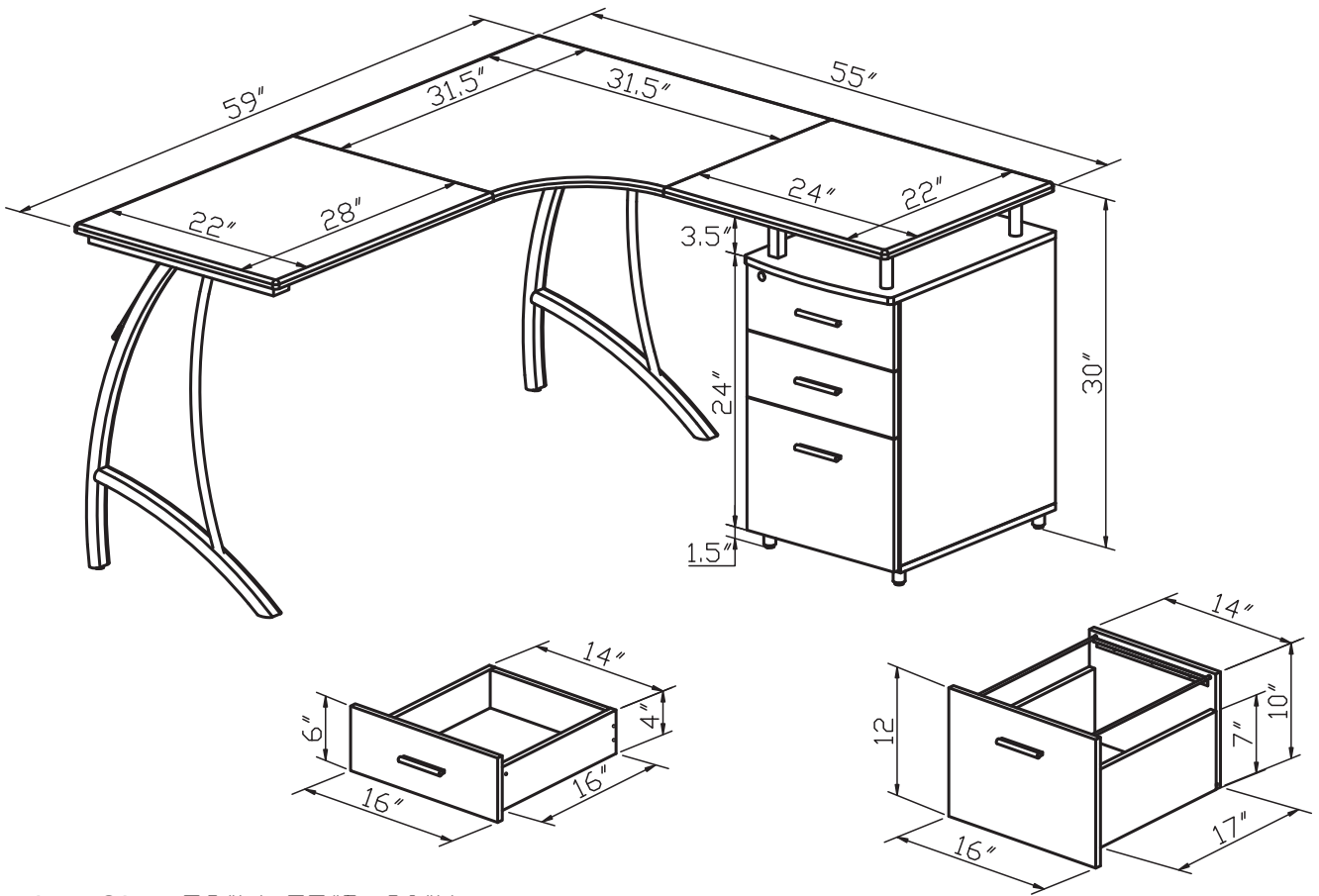

Product Size: 59"Wx55"Dx30"H

## MAXIMUM WEIGHT CAPACITIES

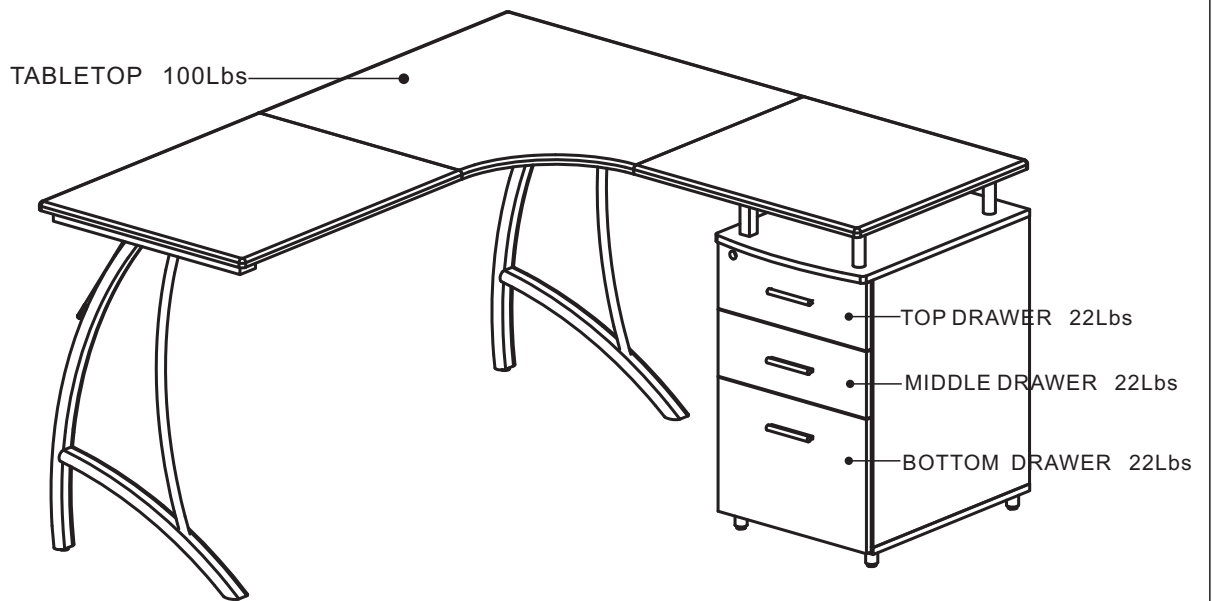





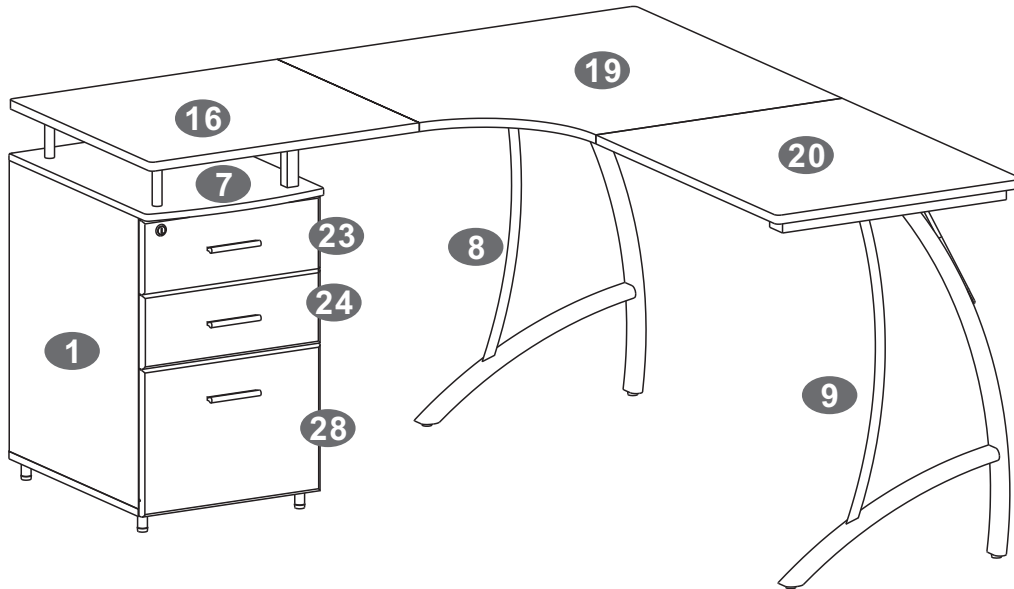

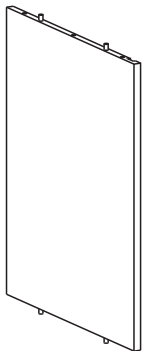
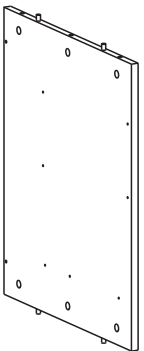
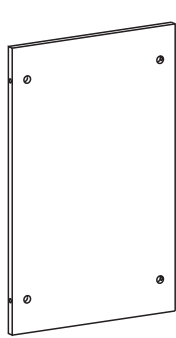
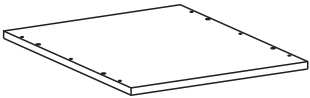
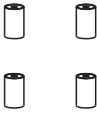
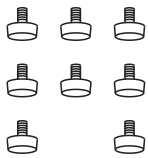
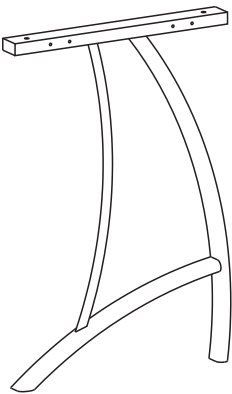
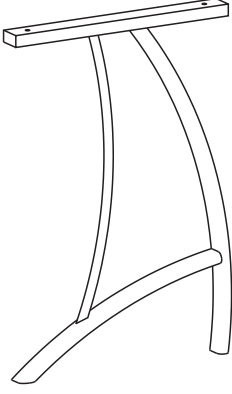
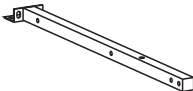
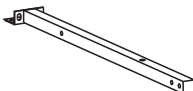
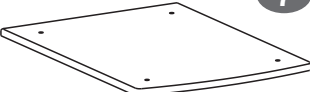
**DO NOT** exceed this limit  
Please use care and good judgement  
when placing objects on wood surface

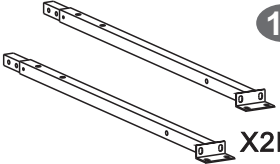
▪ PARTS LIST    ▪ LISTA DE PIEZAS

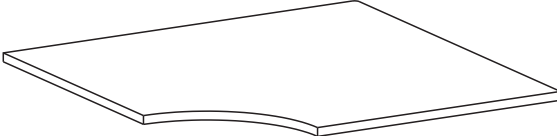
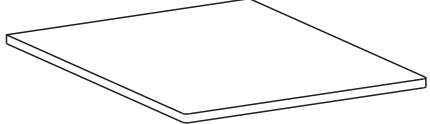
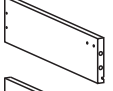
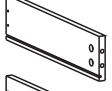
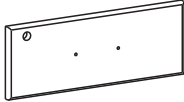
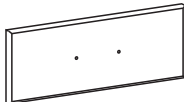
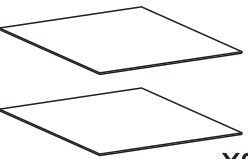
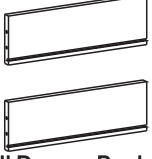
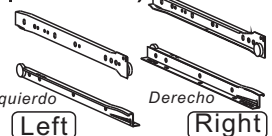
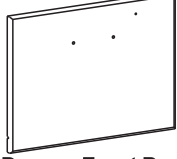
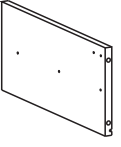
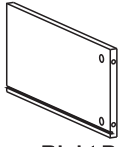
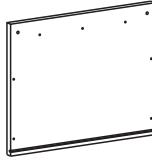
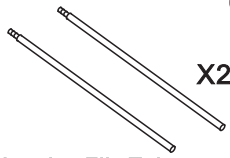
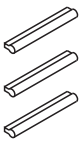
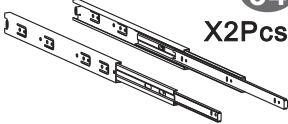
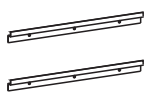
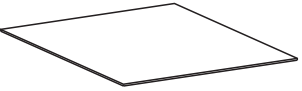

<p><b>1</b></p>  <ul style="list-style-type: none"> <li>▪ Left Panel</li> <li>▪ Panel izquierdo</li> </ul>	<p><b>2</b></p>  <ul style="list-style-type: none"> <li>▪ Right Panel</li> <li>▪ Panel derecho</li> </ul>	<p><b>3</b></p>  <ul style="list-style-type: none"> <li>▪ Back Panel</li> <li>▪ Panel posterior</li> </ul>	<p><b>4</b></p>  <ul style="list-style-type: none"> <li>▪ Bottom Panel</li> <li>▪ Panel inferior</li> </ul> <hr/> <p><b>5</b></p>  <p>X4Pcs</p> <ul style="list-style-type: none"> <li>▪ Bottom Support Tube</li> <li>▪ Tubo de soporte inferior</li> </ul>
<p><b>6</b></p>  <p>X8Pcs</p> <ul style="list-style-type: none"> <li>▪ Studs</li> <li>▪ Topes</li> </ul>	<p><b>8</b></p>  <ul style="list-style-type: none"> <li>▪ Left Frame</li> <li>▪ Estructura izquierda</li> </ul>	<p><b>9</b></p>  <ul style="list-style-type: none"> <li>▪ Right Frame</li> <li>▪ Estructura derecha</li> </ul>	<p><b>10</b></p>  <ul style="list-style-type: none"> <li>▪ Left Front Connect Tube</li> <li>▪ Tubo frontal de conexión izquierdo</li> </ul> <hr/> <p><b>11</b></p>  <ul style="list-style-type: none"> <li>▪ Left Back Connect Tube</li> <li>▪ Tubo posterior de conexión derecho</li> </ul>
<p><b>7</b></p>  <ul style="list-style-type: none"> <li>▪ Cabinet Top Panel</li> <li>▪ Panel superior del gabinete</li> </ul>			

 <p><b>12</b> X2Pcs</p> <ul style="list-style-type: none"> <li>▪ Right Connect Tube</li> <li>▪ Tubo de conexión derecho</li> </ul>	 <p><b>13</b></p> <ul style="list-style-type: none"> <li>▪ Right Support Structure</li> <li>▪ Estructura de soporte derecha</li> </ul>	 <p><b>14</b></p> <ul style="list-style-type: none"> <li>▪ Left Support Structure</li> <li>▪ Estructura de soporte izquierda</li> </ul>	 <p><b>15</b> X2Pcs</p> <ul style="list-style-type: none"> <li>▪ Top Support Tube</li> <li>▪ Tubo de soporte superior</li> </ul>
 <p><b>16</b></p> <ul style="list-style-type: none"> <li>▪ Small Table Panel</li> <li>▪ Panel de mesa pequeño</li> </ul>		 <p><b>17</b> X2Pcs</p> <ul style="list-style-type: none"> <li>▪ Long Tube</li> <li>▪ Tubo largo</li> </ul>	 <p><b>18</b></p> <ul style="list-style-type: none"> <li>▪ Support Frame</li> <li>▪ Estructura de soporte superior</li> </ul>
 <p><b>19</b></p> <ul style="list-style-type: none"> <li>▪ Corner Table Panel</li> <li>▪ Panel de mesa esquinero</li> </ul>		 <p><b>20</b></p> <ul style="list-style-type: none"> <li>▪ Big Table Panel</li> <li>▪ Panel de mesa grande</li> </ul>	
 <p><b>21</b> X2Pcs</p> <ul style="list-style-type: none"> <li>▪ Small Drawer Left Panel</li> <li>▪ Panel izquierdo de gaveta pequeña</li> </ul>	 <p><b>22</b> X2Pcs</p> <ul style="list-style-type: none"> <li>▪ Small Drawer Right Panel</li> <li>▪ Panel derecho de gaveta pequeña</li> </ul>	 <p><b>23</b></p> <ul style="list-style-type: none"> <li>▪ Top Drawer Front Panel</li> <li>▪ Panel frontal de gaveta superior</li> </ul>	 <p><b>24</b></p> <ul style="list-style-type: none"> <li>▪ Middle Drawer Front Panel</li> <li>▪ Panel frontal de gaveta del medio</li> </ul>
 <p><b>25</b> X2Pcs</p> <ul style="list-style-type: none"> <li>▪ Small Drawer Bottom Panel</li> <li>▪ Panel inferior de gaveta inferior</li> </ul>	 <p><b>26</b></p> <ul style="list-style-type: none"> <li>▪ Small Drawer Back Panel</li> <li>▪ Panel posterior de gaveta pequeña</li> </ul>	<p><b>27</b> 2Sets (4pcs each set)</p>  <p>Izquierdo (Left)      Derecho (Right)</p> <ul style="list-style-type: none"> <li>▪ Small Drawer Slider</li> <li>▪ Deslizador de gaveta pequeña</li> </ul>	 <p><b>28</b></p> <ul style="list-style-type: none"> <li>▪ File Drawer Front Panel</li> <li>▪ Panel frontal de gaveta de archivo</li> </ul>
 <p><b>29</b></p> <ul style="list-style-type: none"> <li>▪ File Drawer Left Panel</li> <li>▪ Panel izquierdo de gaveta de archivo</li> </ul>	 <p><b>30</b></p> <ul style="list-style-type: none"> <li>▪ File Drawer Right Panel</li> <li>▪ Panel derecho de gaveta de archivo</li> </ul>	 <p><b>31</b></p> <ul style="list-style-type: none"> <li>▪ File Drawer Back Panel</li> <li>▪ Panel posterior de gaveta de archivo</li> </ul>	 <p><b>32</b> X2Pcs</p> <ul style="list-style-type: none"> <li>▪ Hanging File Tubes</li> <li>▪ Tubo de sostén para carpeta</li> </ul>
 <p><b>33</b> X3Pcs</p> <ul style="list-style-type: none"> <li>▪ Handle</li> <li>▪ Manija</li> </ul>	 <p><b>34</b> X2Pcs</p> <ul style="list-style-type: none"> <li>▪ File Drawer Slider</li> <li>▪ Deslizador de gaveta de archivo</li> </ul>	 <p><b>35</b> X2Pcs</p> <ul style="list-style-type: none"> <li>▪ Folder Hanger</li> <li>▪ Colgador para carpeta</li> </ul>	 <p><b>36</b></p> <ul style="list-style-type: none"> <li>▪ File Drawer Bottom Panel</li> <li>▪ Panel inferior de gaveta de archivo</li> </ul>

**37A** **37B** **37C** **37D** **37E** **37F** **37G** **37** **38**

- A, B, C-Metal Plates; D-Lock and Key; E-Metal Bar; F-Screws for 37C; G-Metal Ring
- A, B, C-Metales de cerrojo; D-Cerrojo y llave; E-Barra de cerrojo; F-Tornillo para 37C; G-Aro de metal

- Connect Metal Plate
- Plato metálico de conexión

X2Pcs

▪ SCREWS LIST    ▪ TORNILLOS

PART	QTY.	ITEM		PART	QTY.	ITEM	
<b>A</b>	50	3X15 MM		<b>H</b>	12	4X35 MM	
<b>B</b>	28	6X40 MM		<b>I</b>	6	4X20 MM	
<b>C</b>	6	6X25 MM		<b>J</b>	6	M6	
<b>D</b>	24	6X35 MM		<b>K</b>	16	4X14 MM	
<b>E</b>	18	6X12 MM			1		
<b>F</b>	2	6X115 MM			1		
<b>G</b>	4	6X40 MM			1		

## HOW TO ASSEMBLE USING BOLTS AND CAM LOCKS: CÓMO ENSAMBLAR USANDO LOS PERNOS Y CERRAJES:



▪ Cam bolt  
▪ Perno



▪ Cam lock  
▪ Cerraje

**1.**



**Screw the bolt into the corresponding panel.**

*Atornille el perno al panel correspondiente.*

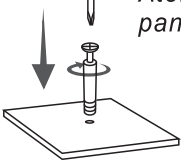

**2.**

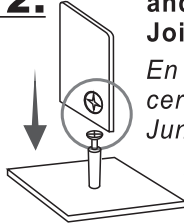

**In the other panel, insert and align the cam lock. Join the panels.**

*En el otro panel, inserte el cerraje y alinee. Junte los paneles.*

**3.**

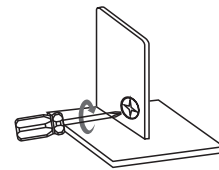

**Turn the cam lock.**  
*Gire el cerraje.*

**If the panel already comes with the cam lock inserted, make sure is aligned:**  
*Si los paneles ya vienen con los cerrajes, asegúrese que estén alineados:*

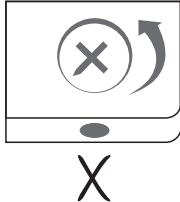

X

**MISALIGNED:  
TURN CAM LOCK  
TO POINT TOWARDS  
THE HOLE**

*DESALINEADO:  
GIRE EL CERRAJE  
PARA QUE APUNTE  
HACIA EL HOYO.*

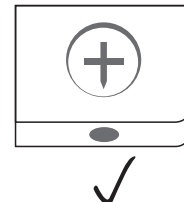

✓

**CORRECT  
CORRECTO**



**GENERAL ASSEMBLY TIPS AND TROUBLESHOOTING DURING ASSEMBLY:**

- \*Before you start assembling, make sure you have all the parts and necessary hardware by doing a quick inventory.**
- \*Follow the assembly instructions step by step, and do not skip any unless advised to do so by RTA PRODUCTS' Customer Service.**
- \*On each step, and to avoid misalignments, always leave screws loose, and do not tighten them until all are in place.**
- \*In wood panels, the laminate might be covering the holes.**  
**If there are no visible holes: Pass the tip of your finger around the area where the hole should be, and press against the surface to feel the indentation.**  
**If the hole looks too small for the screw or bolt: carefully perforate the laminate with the tip of a pen.**

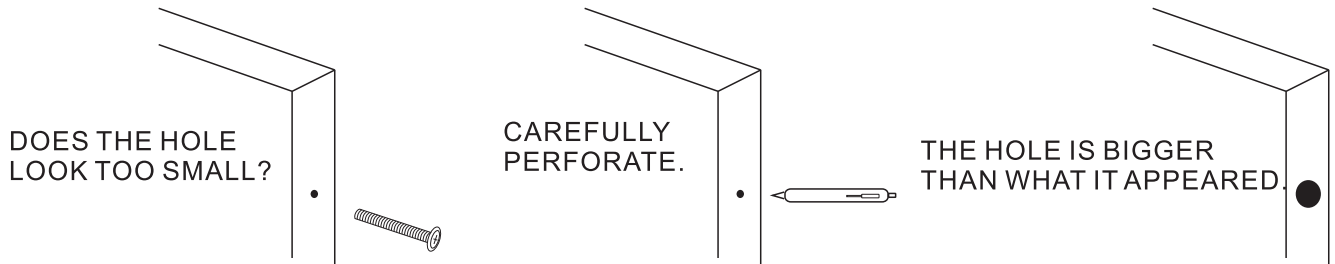

- \*In wood panels, some might have inserts that look like screws. Those inserts are either nuts or cam locks. Make sure they are aligned to receive the screws or bolts.**

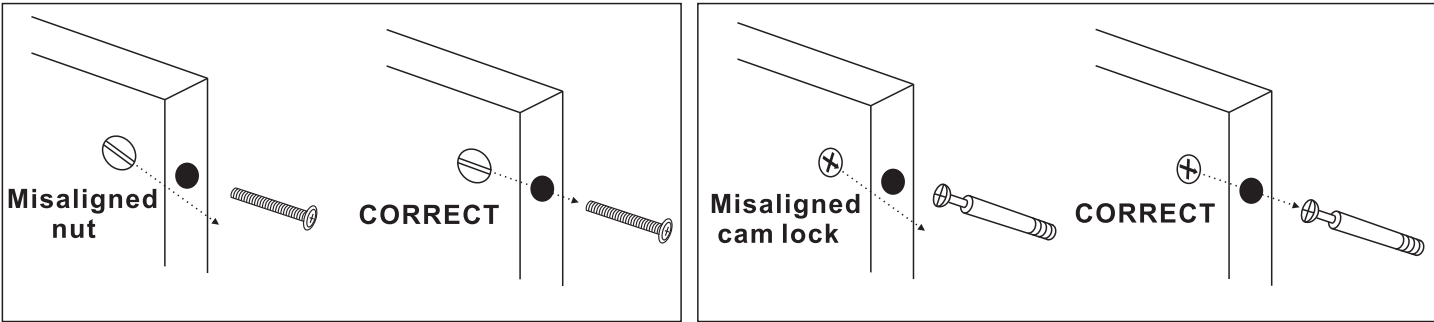

- \*Make sure to use the correct screws or bolts, and do not overtighten them. Using wrong screws or overtightening them might cause damage to the parts, and such damage is not covered by the product's warranty.**

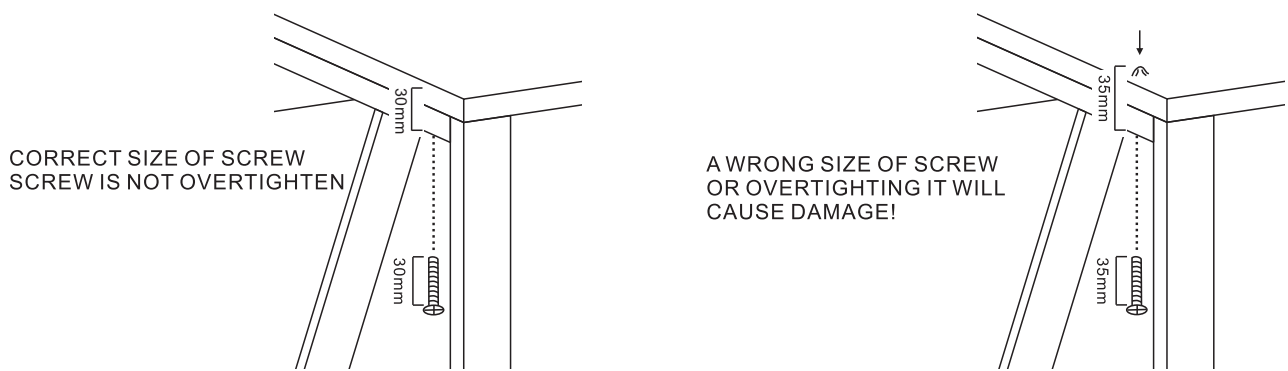



**CONSEJOS PARA RESOLVER PROBLEMAS DURANTE EL ENSAMBLAJE:**

- \*Antes de comenzar, haga un inventario rápido para asegurarse de tener todas las partes y tornillos necesarios.
- \*Siga las instrucciones paso por paso, y no se salte ninguno a menos que se lo aconseje un representante de Servicio al Cliente de RTA PRODUCTS.
- \*Para evitar desalineamientos, en cada paso que haga deje los tornillos medio puestos, y no los apriete hasta que todos estén colocados en sus lugares.
- \*En paneles de madera, el laminado podría cubrir las perforaciones.  
Si no ve los hoyos: Pase la punta del dedo por el area y presione contra la superficie para encontrar el hoyo.  
Si el hoyo luce muy pequeño para el tornillo o perno: Con cuidado perforo el laminado con la punta de un lapicero (bolígrafo, pluma).

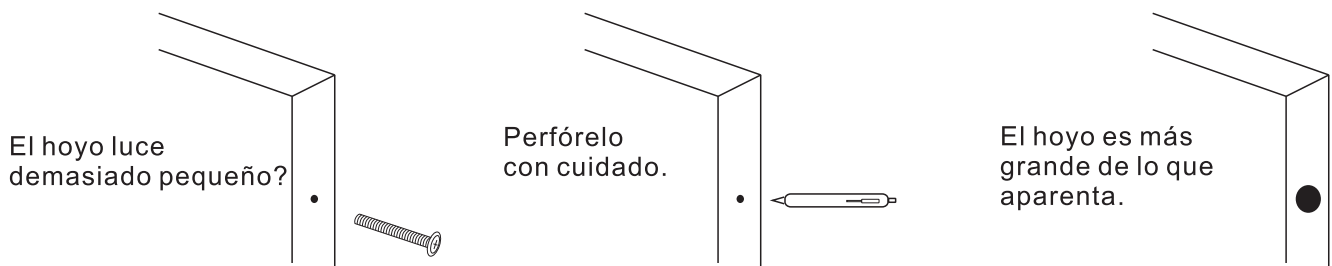

- \*Algunos paneles pueden tener insertados lo que parecen tornillos, pero son tuercas o cerrajes: Asegúrese que estén alineados para recibir el tornillo o perno.

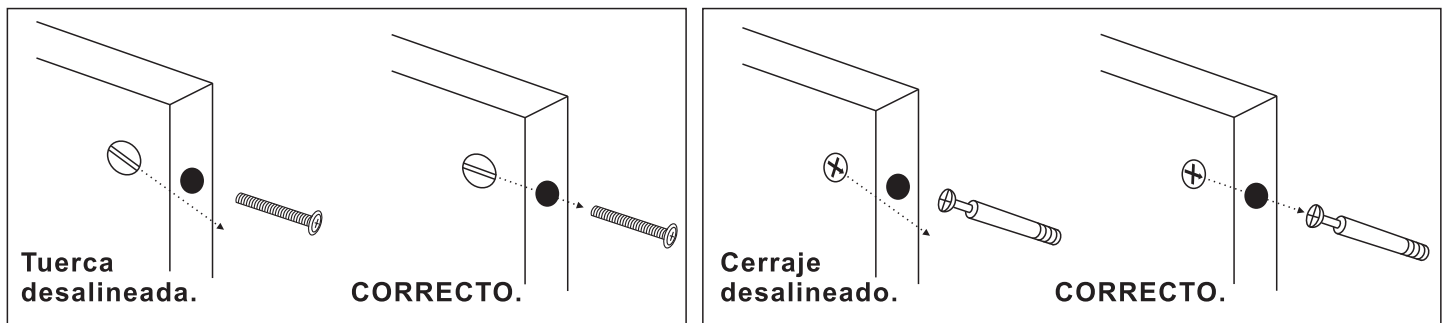

- \*Asegúrese de usar los tornillos y pernos correctos, y no los apriete demasiado. Usar tornillos/pernos de tamaño incorrecto o sobre-apretarlos puede causar daño a las partes, lo cual no es cubierto por la garantía del producto.

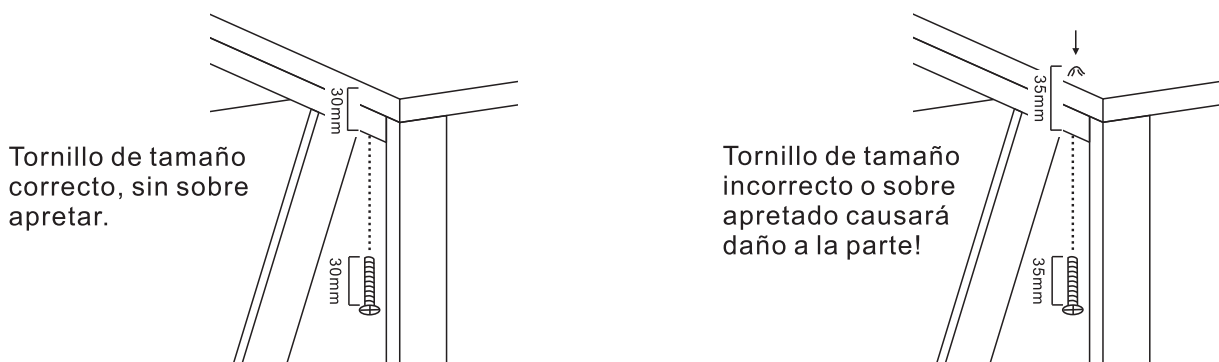

▪ Steps ▪ Pasos

1

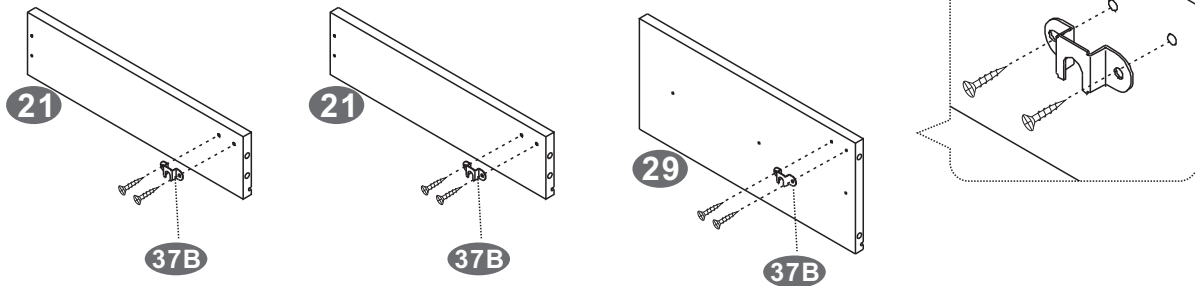

- Use Screws (A) to fix the Metal Plates (37B) to the Small Drawer Left Panels (21) and the File Drawer Left Panel (29).
- Use tornillos (A) para fijar las partes (37B) a los Paneles Izquierdos de las gavetas pequeñas (21) y el Panel Izquierdo de la Gaveta de Archivo (29).

▪ SCREWS ▪ TORNILLOS

**A** 3X15 MM

6PCS



2

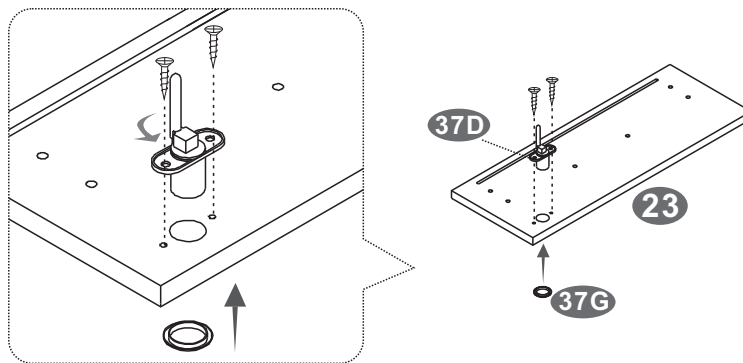

- Press the Metal Ring (37G) into the hole of the Top Drawer Front Panel (23) from the face of the panel. Use Screws (A) to assemble the Lock (37D) to the Top Drawer Front Panel (23).  
Make sure the rod on the lock is facing down, and the key must turn counter-clockwise.
- Presione el Aro de metal (37G) sobre el hueco del Panel Superior de la Gaveta Superior (23) por la parte delantera. Use tornillos (A) para ensamblar el Cerrojo (37D) al Panel Frontal de la Gaveta Superior.  
Asegúrese que el tubo del cerrojo quede en posición hacia abajo, y que la llave gire contra las manecillas del reloj.

▪ SCREWS ▪ TORNILLOS

**A** 3X15 MM

2PCS



3

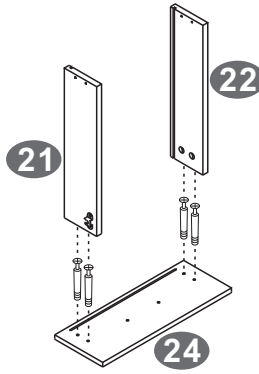
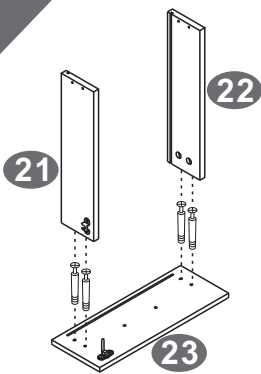

- Screw Bolt (B) to the back of the Top Drawer Front Panel (23) and the Middle Drawer Front Panel (24). Place the Small Drawer Left & Right Panels (21&22) over the Bolts (B) and secure the Panels (21&22) by turning their cam locks.

Slide down the Small Drawer Bottom Panels (25) between the Left, Right, and Front Panels (21, 22, 23), making sure it fits into the grooves.

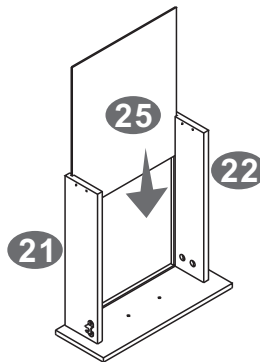
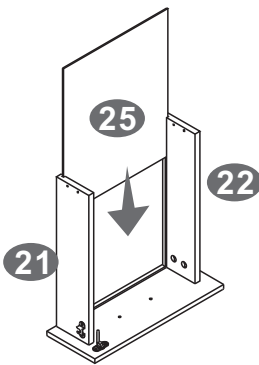

- Atornille los pernos (B) a la parte posterior del Panel Frontal de la Gaveta Superior (24). Coloque los Paneles Derecho e Izquierdo (21 & 22) sobre los pernos (B), y asegure los paneles (21 & 22) haciendo girar los cerrajes. Deslice los Paneles Inferiores de las Gavetas Pequeñas (25) entre los Paneles Izquierdo, derecho y Frontal (21, 22 & 23), asegurándose que quede entre los canales.

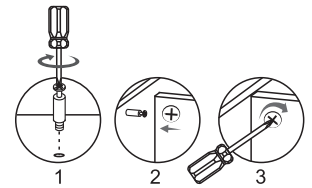

▪ SCREWS ▪ TORNILLOS

**B** 6X40 MM

8PCS



4

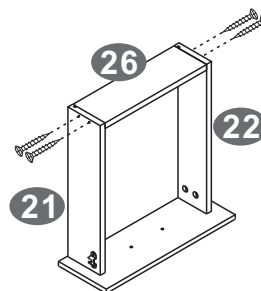
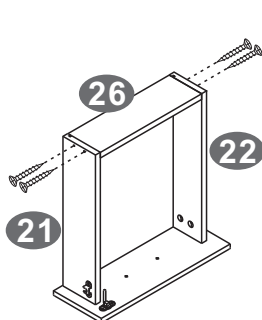

- Use Screws (H) to fix Small Drawer Back Panel (26) between Small Drawer Left & Right Panels (21&22).

Use tornillos (H) para ensamblar el Panel Posterior de las Gavetas Pequeñas (26) entre los paneles (21 & 22).

▪ SCREWS ▪ TORNILLOS

**H** 4X35 MM

8PCS



5

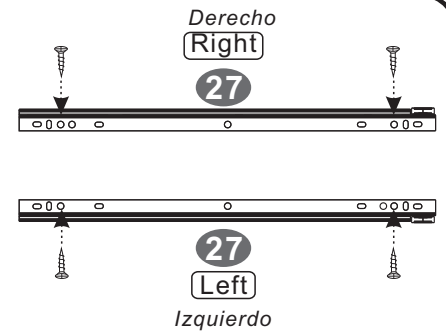
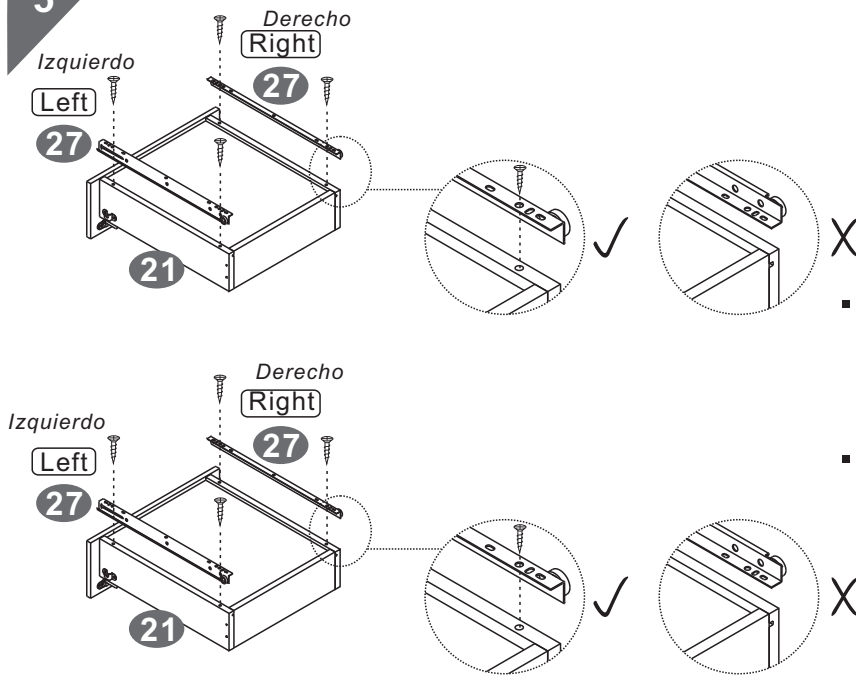

- SEPARATE THE SLIDERS (27) BY THEIR SHAPE: THE "L" SHAPE ONES WILL BE USED IN STEP #5, AND THE FLAT ONES IN STEP #17.
- SEPARARE LOS DESLIZADORES (27) DE ACUERDO A SU FORMA: LOS QUE TIENEN FORMA "L" SE USARÁN EN EL PASO #5, Y LOS PLANOS EN EL PASO #17.

- Align and match the selected holes of the moving part of the Small Drawer Sliders (27) with the pre-drilled holes of the Small Drawer Left & Right Panels (21&22) as illustrated and then use Screws (A) to fix them.
- Alinee los hoyos de la parte movable de los Deslizadores de las Gavetas Pequeñas (27) con los hoyos pre-perforados en los paneles Izquierdo y Derecho (21 & 22) como se muestra, y luego asegúrelos con los tornillos (A).

▪ SCREWS ▪ TORNILLOS

**A** 3X15 MM

8PCS



6

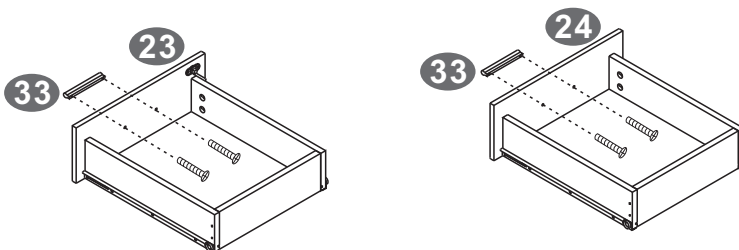

- Use Screws (I) to fix the Handles (33) to the Top Drawer Front Panel (23) and Middle Drawer Front Panel (24).
- Use tornillos (I) para ensamblar las manijas (33) al Panel Frontal de la Gaveta Superior (23) y el Panel Frontal de la gaveta del medio (24).

▪ SCREWS ▪ TORNILLOS

**I** 4X20 MM

4PCS



7

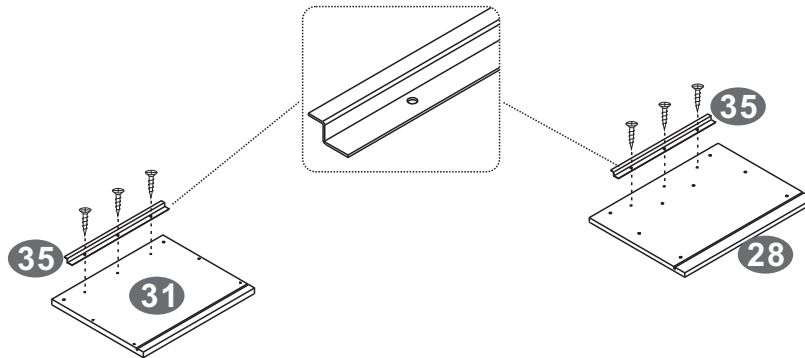

- Use Screws (A) to fix the Folder Hangers (35) to the File Drawer Front & Back Panels (28&31).
- Use tornillos (A) para ensamblar los Colgadores de la Gaveta de Archivo (35) a los paneles (28 & 31).

▪ SCREWS ▪ TORNILLOS

**A** 3X15 MM

6PCS



8

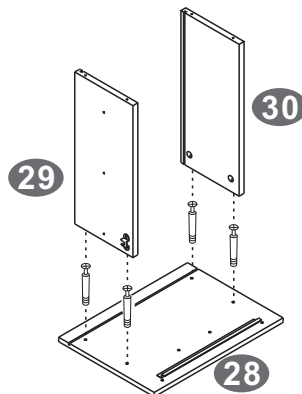

- Screw Bolts (B) to the back of the File Drawer Front Panel (28). Place the File Drawer Left & Right Panels (29&30) over the Bolts (B) and secure the Panels (29&30) by turning their cam locks.
- Atornille los pernos (B) a la parte posterior del Panel Frontal de la Gaveta de Archivo (28). Coloque los Paneles Derecho e Izquierdo (29 & 30) sobre los pernos (B), y asegure los paneles (29 & 30) haciendo girar los cerrajes.

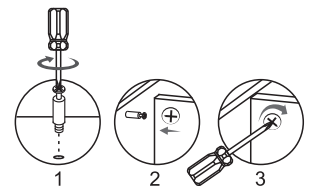

▪ SCREWS ▪ TORNILLOS

**B** 6X40 MM

4PCS



9

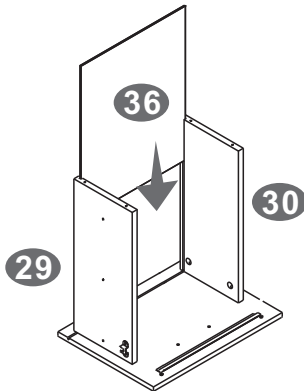

- Slide down the File Drawer Bottom Panel (36) between the Left, Right, and Front Panels (28, 29 & 30), making sure it fits into the grooves.
- *Deslice los Paneles Inferiores de la Gaveta de Archivo (36) entre los Paneles Izquierdo, derecho y Frontal (28, 29 & 30), asegurándose que quede entre los canales.*

10

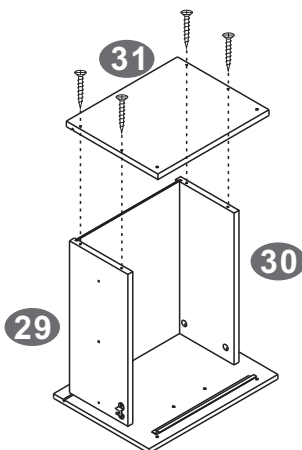

- Use Screws (H) to fix the File Drawer Back Panel (31) to the File Drawer Left & Right Panels (29&30).
- *Use tornillos (H) para ensamblar el Panel Posterior de la Gaveta de Archivo (31) a los paneles Izquierdo y Derecho (29 & 30).*

▪ SCREWS ▪ TORNILLOS

**H** 4X35 MM

4PCS



11

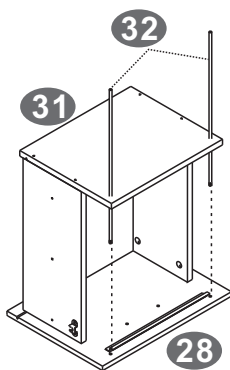

- Insert the Hanging Files Tubes (32) and screw into File Drawer Front Panel (28).
- ⚠ **Attention: Do not over tighten them, as doing so will cause damaged to the panel.**
- *Inserte los Tubos de Sostén para carpetas (32) atornillándolos al Panel Frontal de la Gaveta de Archivo (28).*
- ⚠ **ATENCIÓN: No los apriete demasiado, porque pueden dañar el panel.**

12

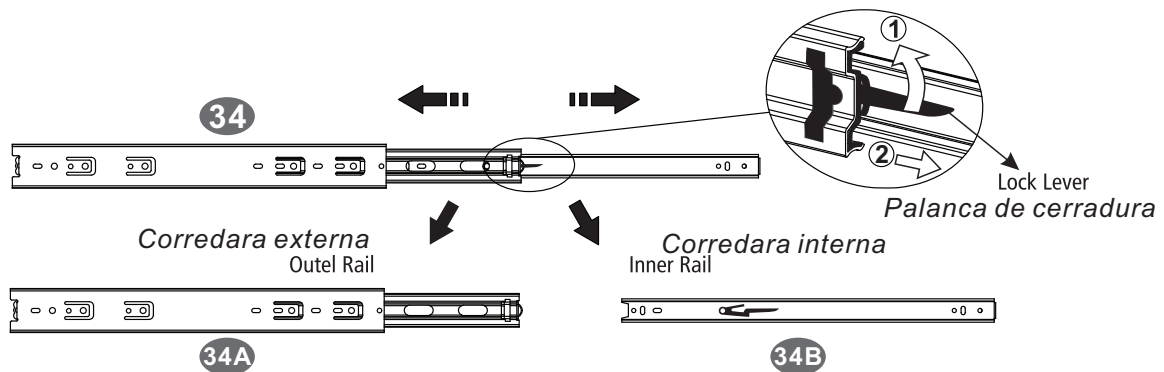

- Open the slider (34) and hold it as shown. Press the locking lever up hard with the tip of your thumb to separate sliders into the outer rail (34a) and the inner rail (34b). (34b) will be used on step# 13, and (34a) on step# 17.
- Abra el deslizador (34) y sosténgalo como se muestra. Presione fuerte la palanca de cierre hacia arriba con la punta del dedo para separar los deslizadores en partes (34a) y (34b). (34b) se usará en el paso #13, y (34a) en el paso #17.

13

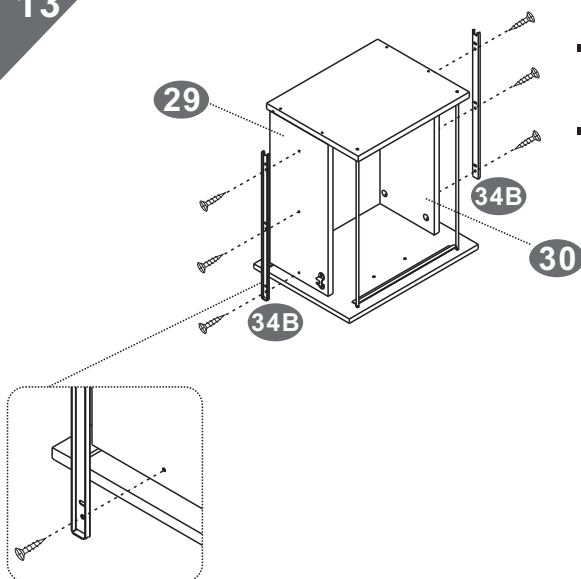

- Use Screws (A) to fix the Inner Rail (34B) to the File Drawer Left & Right Panels (29&30).
- Use tornillos (A) para ensamblar los deslizadores (34B) a los Paneles Izquierdo y Derecho de la Gaveta de Archivo (29 & 30).

▪ SCREWS ▪ TORNILLOS

**A** 3X15 MM

6PCS



14

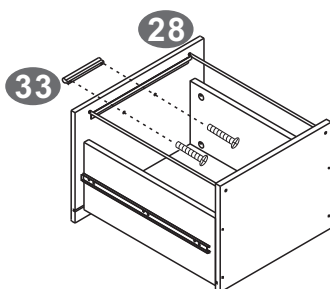

- Use Screws (I) to fix the Handle (33) to the File Drawer Front Panel (28).
- Use tornillos (I) para ensamblar la manija (33) al Panel Frontal de la Gaveta de Archivo (28).

▪ SCREWS ▪ TORNILLOS

**I** 4X20 MM

2PCS



15

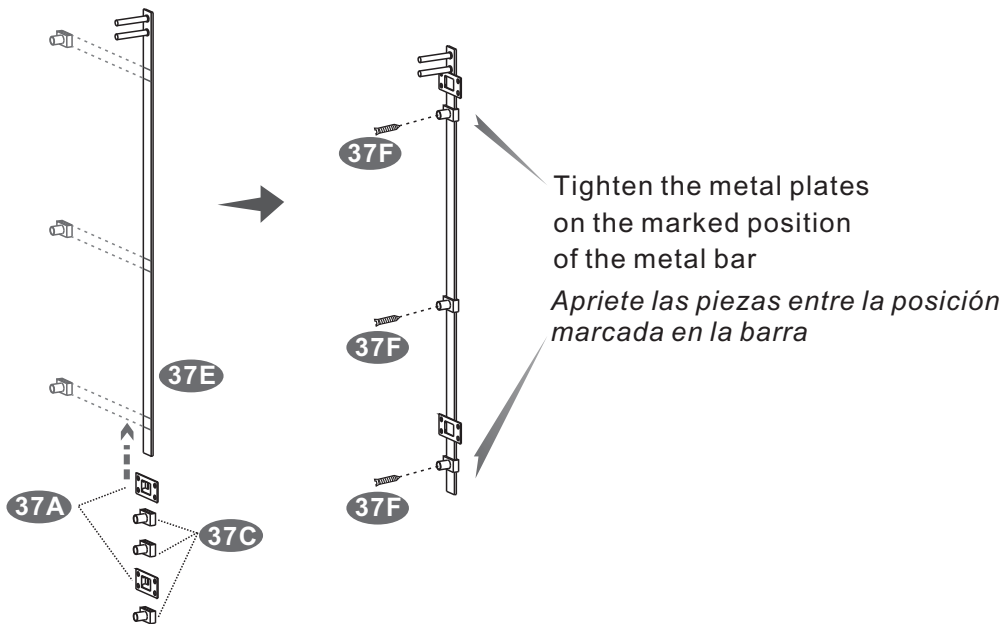

- First slide into the Metal Bar (37E) the 5 Metal Plates in the order shown in the drawing (37A, 37C, 37C, 37A, 37C). Then, tighten the Metal Plates (37C) on the marked position of the Metal Bar (37E) with Screws (37F).
- Primero deslice en la Barra de Metal (37E) las 5 piezas metálicas en el orden mostrado (37A, 37C, 37C, 37A, 37C). Después, apriete las piezas (37C) entre la posición marcada en la barra (37E), con los tornillos (37F).

16

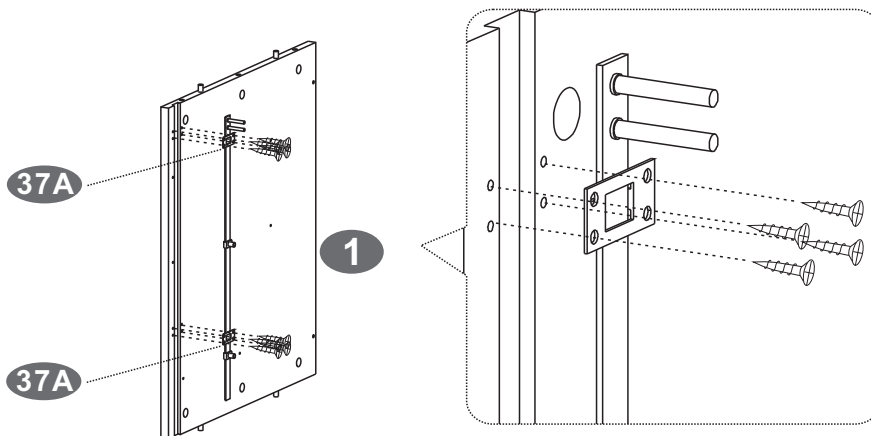

- Use Screws (A) with the Metal Plates (37A) to assemble the Metal Bar (23E) to the Left Panel (1).
- Use tornillos (A) con las piezas (37A) para ensamblar la barra (23E) al panel (1).

▪ SCREWS ▪ TORNILLOS

**A** 3X15 MM

8PCS





17

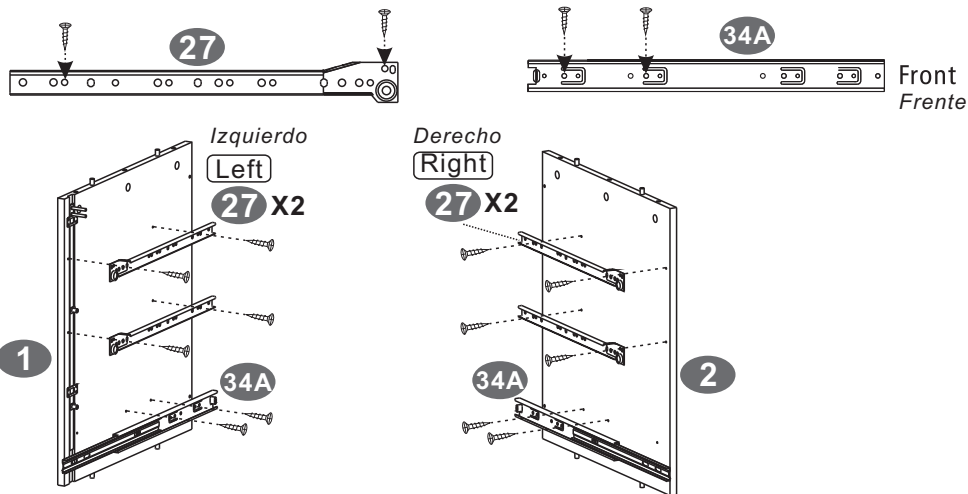

- Use Screws (A) to assemble the Small Drawer Sliders (27) and the Outer Rails (34A) to the Left & Right Panels (1&2). On (27), use the second hole from the front, and third hole from the end. On (34A), use the second and fifth hole from the end. Do not screw (34A) at the front yet.
- Use tornillos (A) para ensamblar los Deslizadores de la Gaveta Pequeña (27) y los rieles (34A) a los paneles Izquierdo y Derecho (1 & 2). En (27), use el Segundo hueco del frente, y el tercero del final. En (34A), use el Segundo y quinto hueco del final. No atornille (34A) al frente todavía.

▪ SCREWS ▪ TORNILLOS

**A** 3X15 MM

12PCS



18

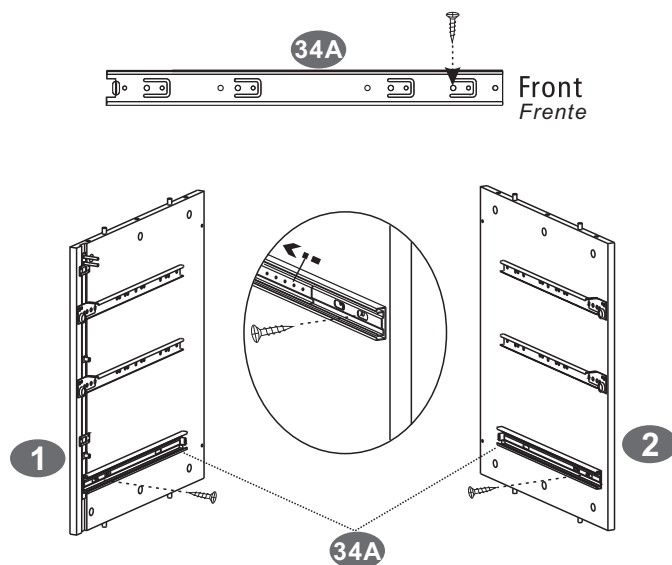

- Close the rails (34A) and slide the part with the bearings towards the back. The front hole will be visible on (34A), and secure them with screws (A).
- Cierre los rieles (34A) y deslice la balinera hacia atrás. El hueco del frente quedará visible en (34A), y asegúrelos con tornillos (A).

▪ SCREWS ▪ TORNILLOS

**A** 3X15 MM

2PCS



19

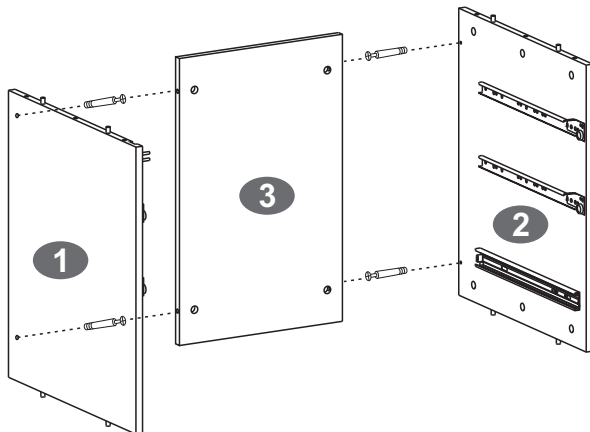

- First screw the Bolts (B) on the inside face of the Left & Right Panels (1&2). Place the Back Panel (3) over the Bolts and tighten all cam locks on the inside face of Back Panel (3).
- Primero atornille los pernos (B) en la parte interior de los Paneles Izquierdo y Derecho (1 & 2). Coloque el Panel Posterior (3) sobre los pernos y gire todos los cerrajes de la parte interior del Panel Posterior (3).

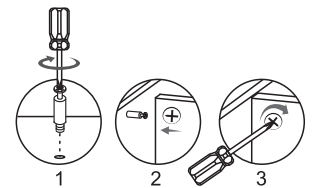

▪ SCREWS ▪ TORNILLOS

**B** 6X40 MM

4PCS



20

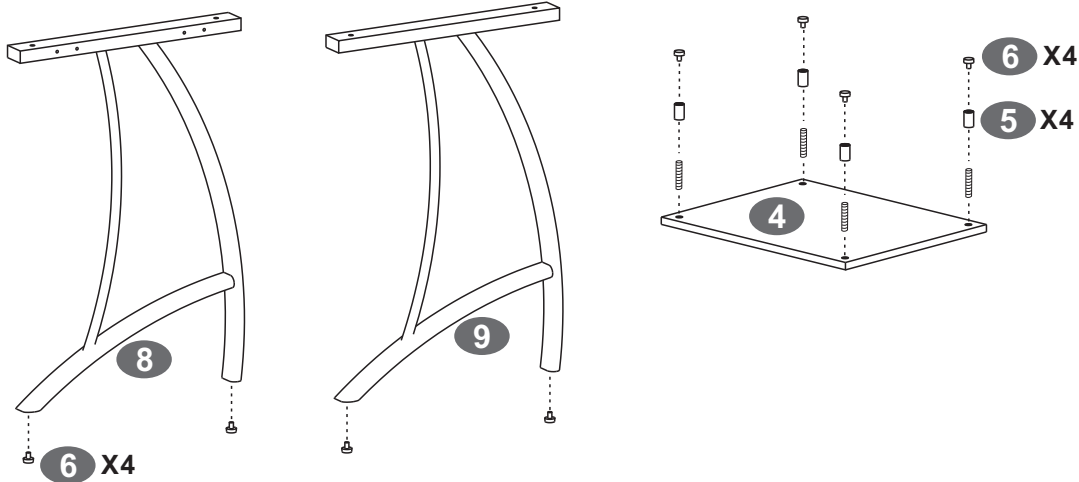

- Fix the Studs (6) to the Left & Right Frames (8&9). Use Screws (C) to assemble the Legs Bottom Support Tube (5) to the Bottom Panel (4). Then fix the Studs (6) to the tubes (5).
- Inserte los Topes (6) a las Estructuras Izquierda y Derecha (8 & 9). Use tornillos (C) para ensamblar los Tubos de Soporte Inferior (5) al Panel Inferior (4). Luego ensamble los Topes (6) a los tubos (5).

▪ SCREWS ▪ TORNILLOS

**C** 6X25 MM

4PCS

21

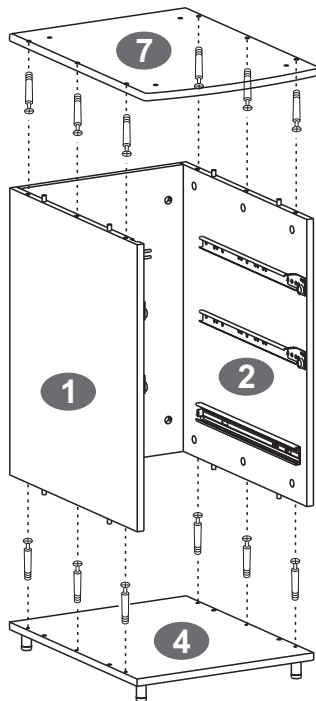

- Screw the Bolts (B) in the corresponding holes of the back face of the Bottom & Top Panels (4&7). Then place the Left & Right Panels (1&2) over the bolts of the Bottom Panel (4). Then insert the bolts of the Top Panel (7) into the holes of the Left & Right Panels (1&2). Finally tighten the cam locks in the inside faces of the Left & Right Panels (1&2).
- Atornille los pernos (B) en los hoyos correspondientes en la parte posterior de los Paneles Superior e Inferior (4 & 7) . Luego coloque los Paneles Izquierdo y Derecho (1 & 2) sobre los pernos del Panel Inferior (4). Luego inserte los pernos del Panel Superior (7) en los hoyos de los Paneles Izquierdo y Derecho (1 & 2). Por ultimo, gire los cerrajes en la parte interior de los Paneles Izquierdo y Derecho (1 & 2).

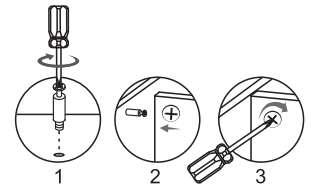

▪ SCREWS ▪ TORNILLOS

**B** 6X40 MM

12PCS



22

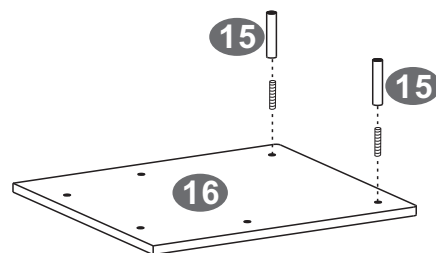

- Use Screws (C) to fix the Top Support Tubes (15) to the Small Table Panel (16).
- Use tornillos (C) para unir los los Tubos de Soporte Superior (15) al Panel de mesa pequeño (16).

▪ SCREWS ▪ TORNILLOS

**C** 6X25 MM

2PCS

23

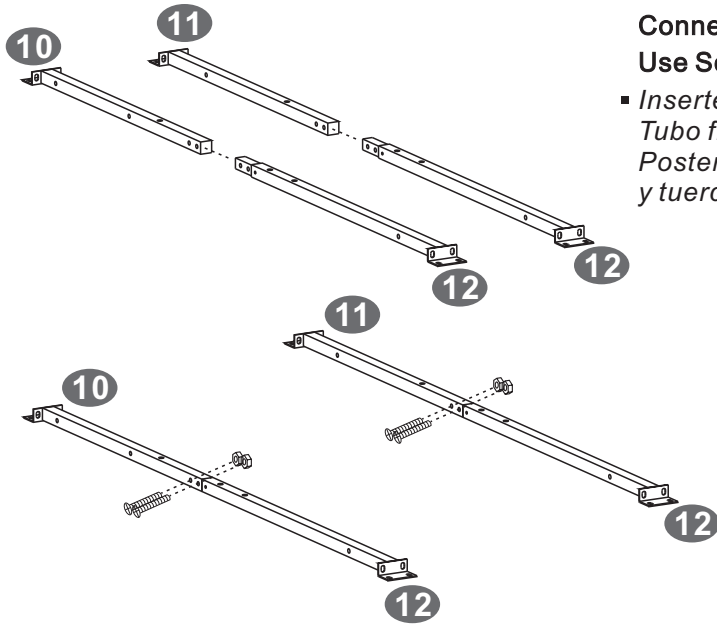

- Insert the Right Connect Tubes (12) into the Left Front Connect Tube (10) and Left Back Connect Tube (11). Use Screws (D&J) to tighten them.
- *Inserte los Tubos de Conexión Derecho (12) en el Tubo frontal de Conexión Izquierdo (10) y el Tubo Posterior de Conexión Derecho (11). Use tornillos y tuercas (D & J) para asegurarlos.*

SCREWS		TORNILLOS	
<b>D</b>	6X35 MM		4PCS
<b>J</b>	M6		4PCS

\*\*There are 2 options to assemble your desk, please choose it according to your preference, and follow the next steps A or B.

*\*\*Hay 2 opciones para ensamblar su escritorio, por favor escoja una de acuerdo a su preferencia, y continúe con los siguientes pasos A o B.*

**A**

A1-A7

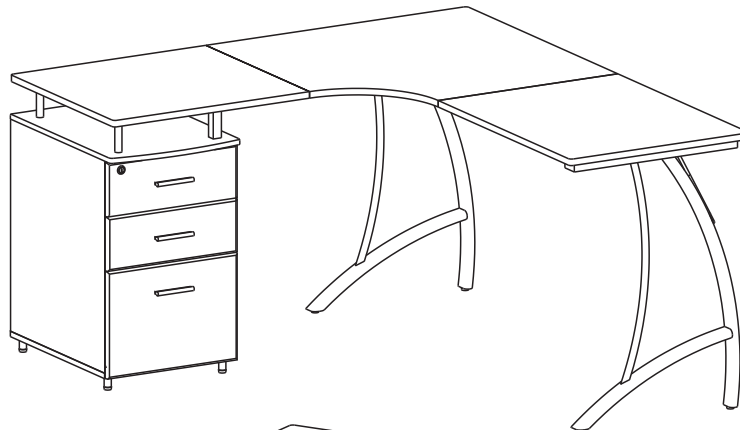

**B**

B1-B7



A1

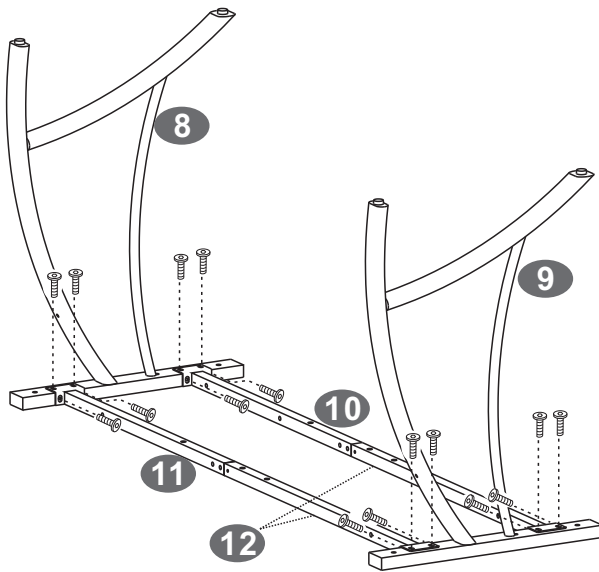

- Use Screws (E) to fix the Left Front Connect Tube, Left Back Connect Tube and Right Connect Tube (10, 11&12) to the Left & Right Frames (8&9). Please pay attention to the position of the tubes as shown.
- Use tornillos (E) para ensamblar el Tubo Conector Frontal de la Izquierda, el Tubo posterior de conexión derecha y el Tubo Conector derecho (10, 11 & 12) a las estructuras Izquierda y Derecha (8 & 9). Por favor fijese bien en las posiciones de los tubos tal como se muestra.

▪ SCREWS ▪ TORNILLOS

**E** 6X12 MM

16PCS

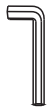

A2

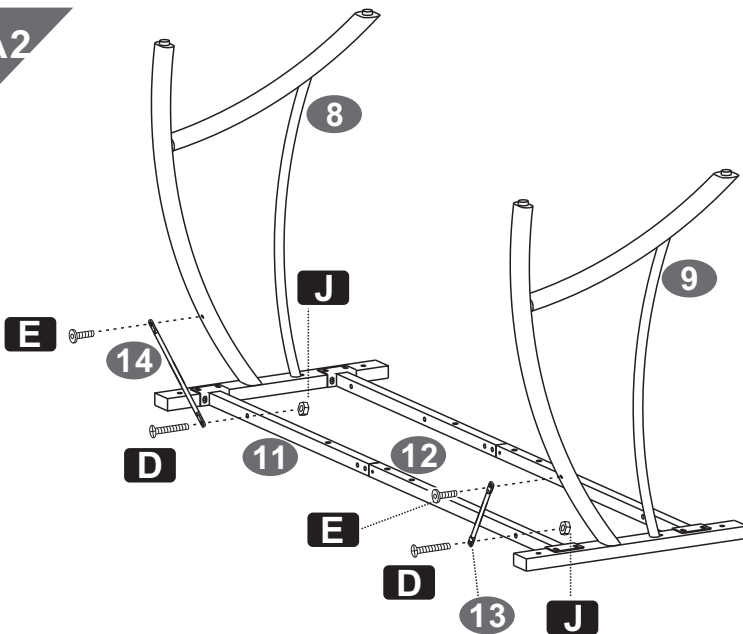

- Assemble the Right Support Structure (13) to the Right Frame (9) and Right Connect Tube (12) using Screws (D, E, J). Assemble the Left Support Structure (14) to the Left Frame (8) and Left Back Connect Tube (11) using Screws (D, E, J). Please pay attention to the position of the screws.
- Ensamble la Estructura de Soporte Derecha (13) a la Estructura Derecha (9) y el Tubo Conector Derecho (12) usando tornillos (D, E, J). Ensamble la Estructura de soporte izquierda (14) a la Estructura Izquierda (8) y el Tubo posterior de conexión derecho (11) usando tornillos (D, E, J). Por favor fijese bien en las posiciones de los tornillos tal como se muestra.

▪ SCREWS ▪ TORNILLOS

**D** 6X35 MM

2PCS

**E** 6X12 MM

2PCS

**J** M6

2PCS



A3

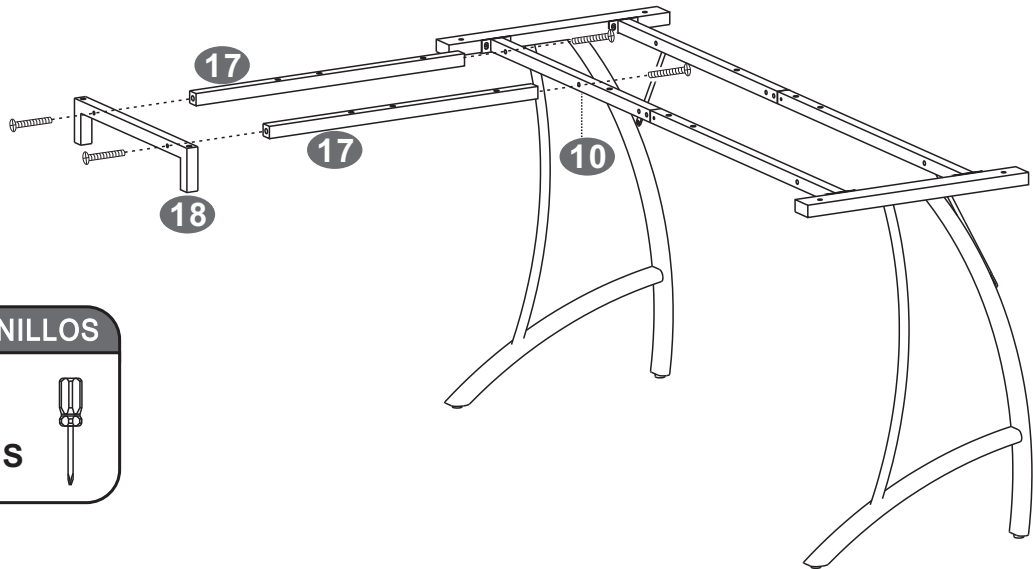

▪ SCREWS ▪ TORNILLOS

**G** 6X40 MM

4PCS



▪ Use Screws (G) to assemble the Long Tubes (17) between the Left Front Connect Tube (10) and the Support Frame (18).

▪ Use tornillos (G) para ensamblar los Tubos Largos (17) entre el Tubo frontal de conexión izquierdo (10) y la Estructura de soporte superior (18).

A4

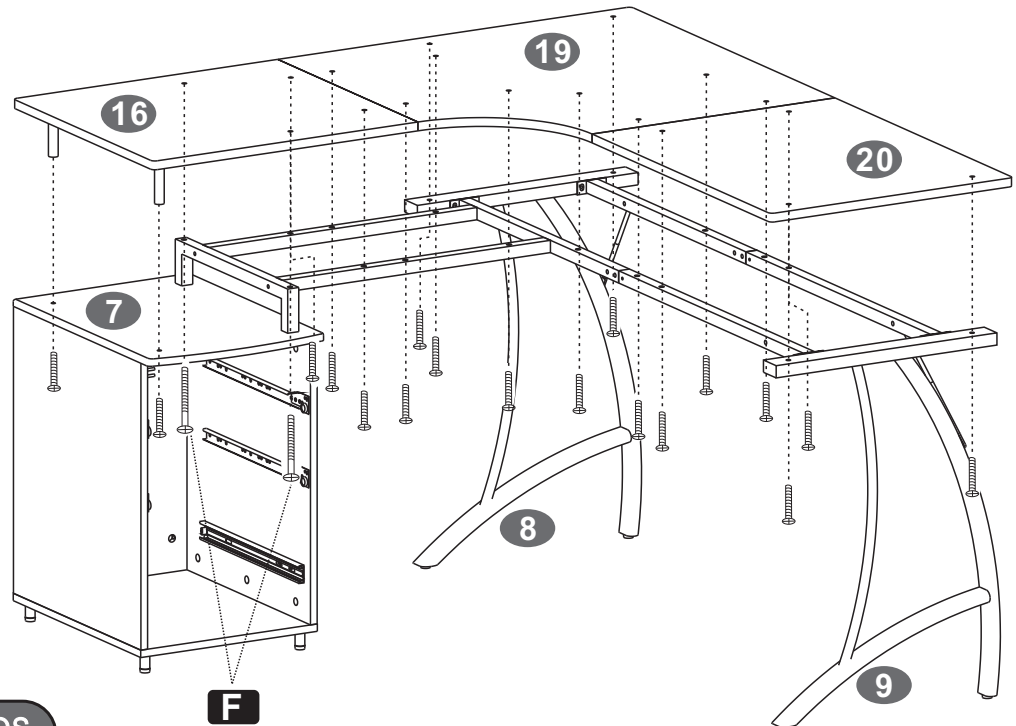

▪ SCREWS ▪ TORNILLOS

**D** 6X35 MM

18PCS



**F** 6X115 MM

2PCS



▪ Assemble the Small Table Panel (16), the Corner Table Panel (19) and the Big Table Panel (20) using Screws (D&F).

**DO NOT TIGHTEN ANY SCREWS UNTILL ALL ARE IN PLACE.**

**Please pay attention of the position of the screws.**

▪ Ensamble el Panel de mesa pequeño (16), Panel de Mesa Esquinero (19), y el Panel de Mesa Grande (20) usando tornillos (D & F).

**NO APRIETE NINGUN TORNILLO HASTA QUE TODOS ESTÉN COLOCADOS.**  
Por favor fíjese bien en las posiciones de los tornillos tal como se muestra.

A5

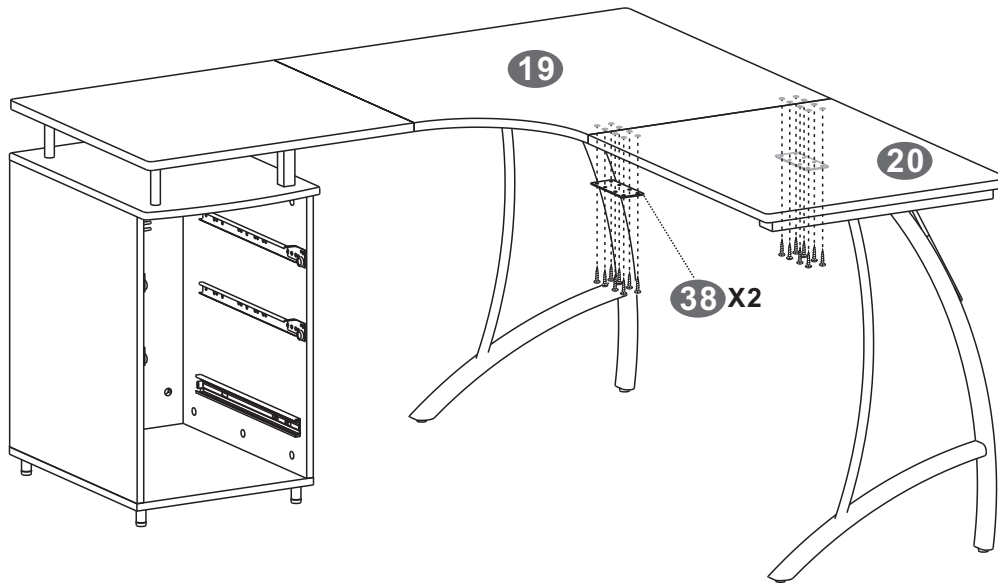

- Assemble the Connect Metal Plates (38) on the bottom and between the Corner Table Panel (19) and the Big Table Panel (20) using Screws (K).
- Ensamble los Platos Metálico de Conexión (38) por debajo y entre medio del Panel de Mesa Esquinero (19) y el Panel de Mesa Grande (20) usando tornillos (K).

▪ SCREWS ▪ TORNILLOS

**K** 4X14 MM

16PCS



A6

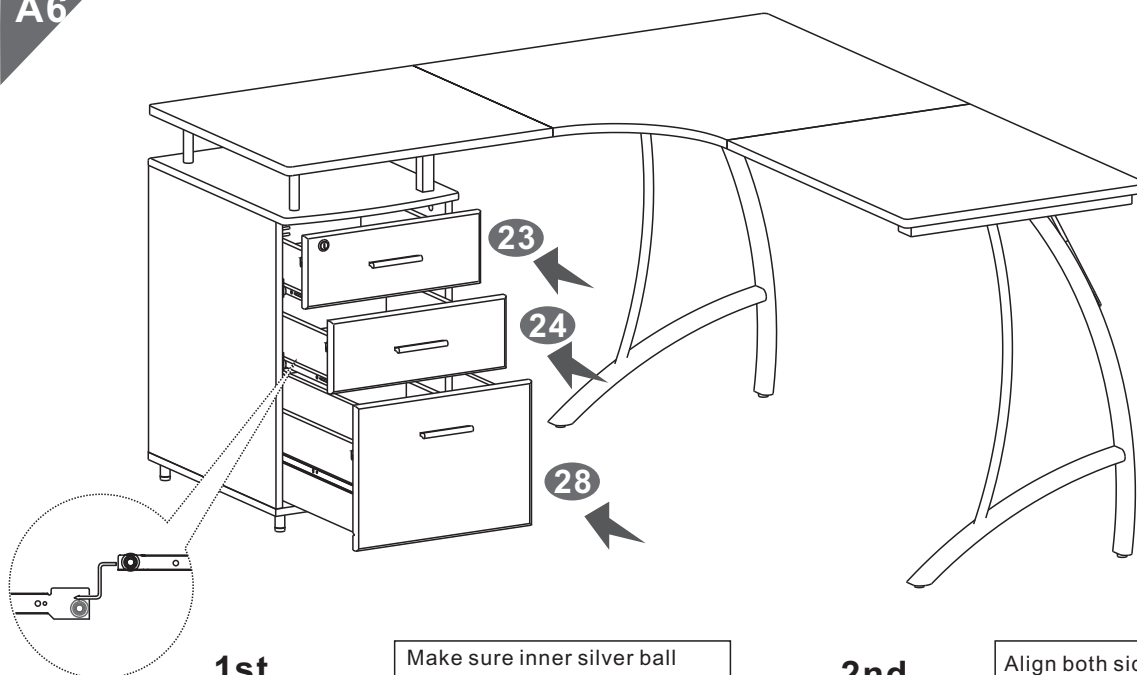

1st

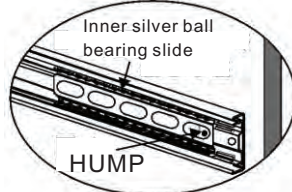

Make sure inner silver ball bearing slide is at the front of the slide mount and in lock position (over the hump), as shown.  
Asegúrese que las balineras estén hacia el frente como se muestra.

2nd

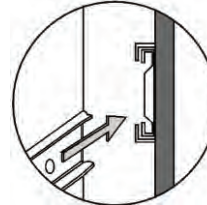

Align both sides of slide runners to slide mounts' openings, then slide all the way in. Apply small force to insert completely if needed.  
Alinee los deslizadores en ambos lados y deslice lenta y firmemente. Aplique un poco de fuerza si fuera necesario.

- Carefully slide drawers onto rails and push firmly and evenly until they are completely closed.
- Deslice firme pero cuidadosamente las gavetas hasta que queden completamente cerradas.

A7

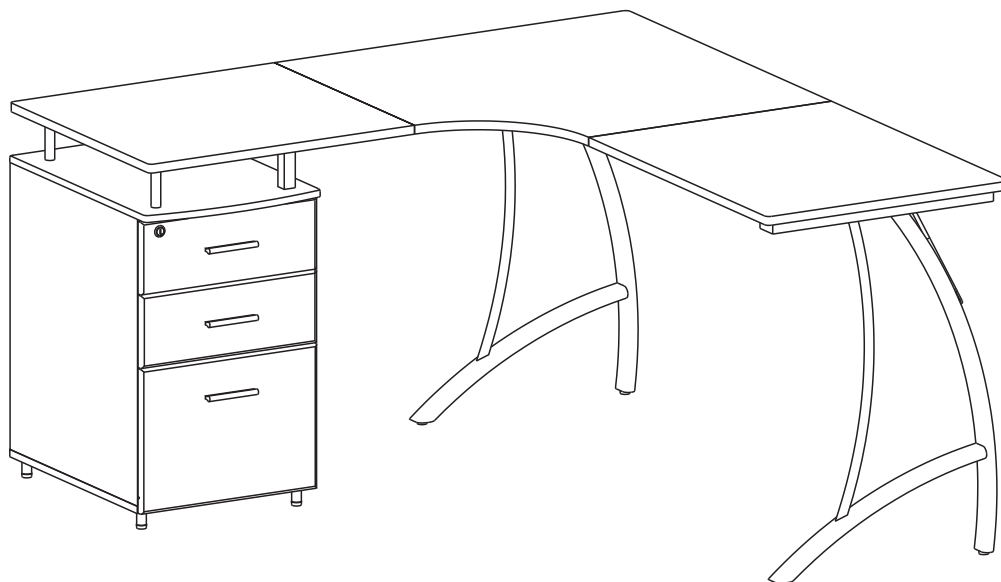

B1

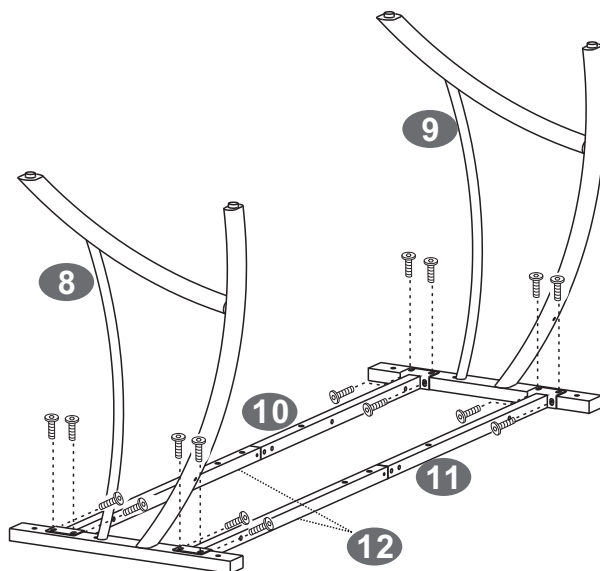

- Use Screws (E) to fix the Left Front Connect Tube, Left Back Connect Tube and Right Connect Tube (10, 11&12) to the Left & Right Frames (8&9). Please pay attention to the position of the tubes as shown.
- Use tornillos (E) para ensamblar el Tubo Conector Frontal de la Izquierda, el Tubo posterior de conexión derecha y el Tubo Conector derecho (10, 11 & 12) a las estructuras Izquierda y Derecha (8 & 9). Por favor fijese bien en las posiciones de los tubos tal como se muestra.

▪ SCREWS ▪ TORNILLOS

**E** 6X12 MM

16PCS





B2

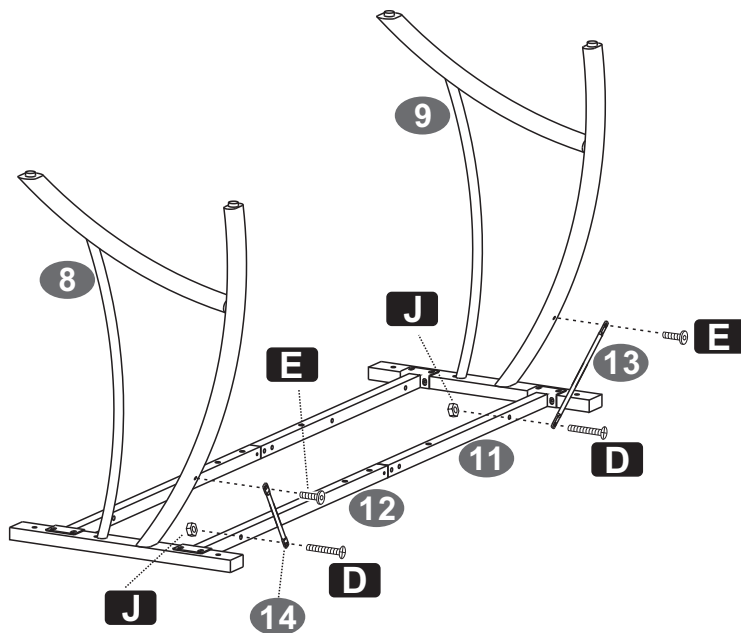

- Assemble the Right Support Structure (13) to the Right Frame (9) and Left Back Connect Tube (11) using Screws (D, E, J). Assemble the Left Support Structure (14) to the Left Frame (8) and Right Connect Tube (12) with using Screws (D, E, J). Please pay attention to the position of the screws.
- *Ensamble la Estructura de Soporte Derecha (13) a la Estructura Derecha (9) y el Tubo Posterior de Conexión Derecho (11) usando tornillos (D, E, J). Ensamble la Estructura de soporte izquierda (14) a la Estructura Izquierda (8) y el Tubo de conexión derecho (12) usando tornillos (D, E, J). Por favor fijese bien en las posiciones de los tornillos tal como se muestra.*

▪ SCREWS ▪ TORNILLOS	
<b>D</b> 6X35 MM	
 2PCS	
<b>E</b> 6X12 MM	
 2PCS	
<b>J</b> M6	
 2PCS	

B3

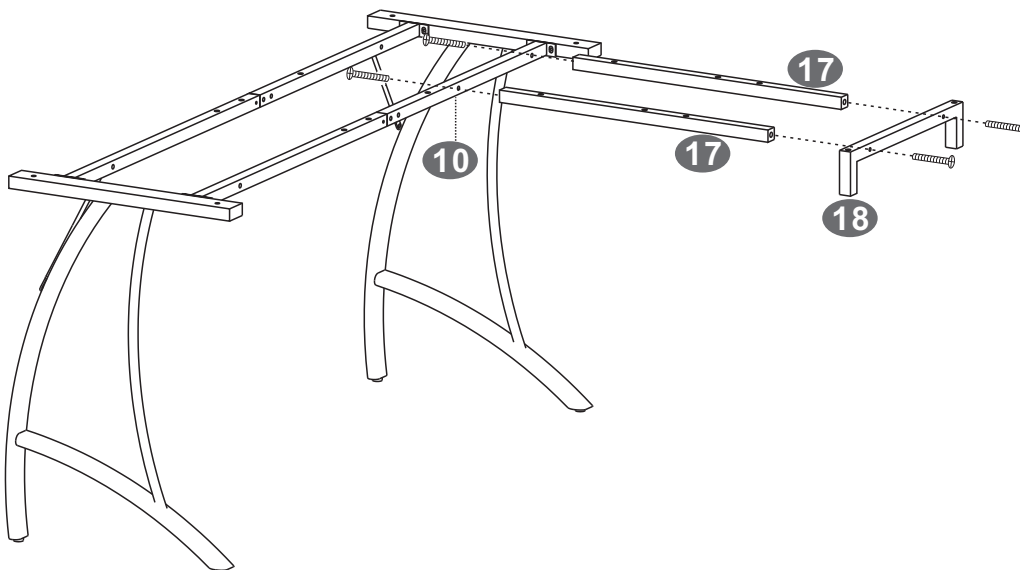

- Use Screws (G) to assemble the Long Tubes (17) between the Left Front Connect Tube (10) and the Support Frame (18).
- *Use tornillos (G) para ensamblar los Tubos Largos (17) entre el Tubo frontal de conexión izquierdo (10) y la Estructura de soporte superior (18).*

▪ SCREWS ▪ TORNILLOS	
<b>G</b> 6X40 MM	
 4PCS	

B4

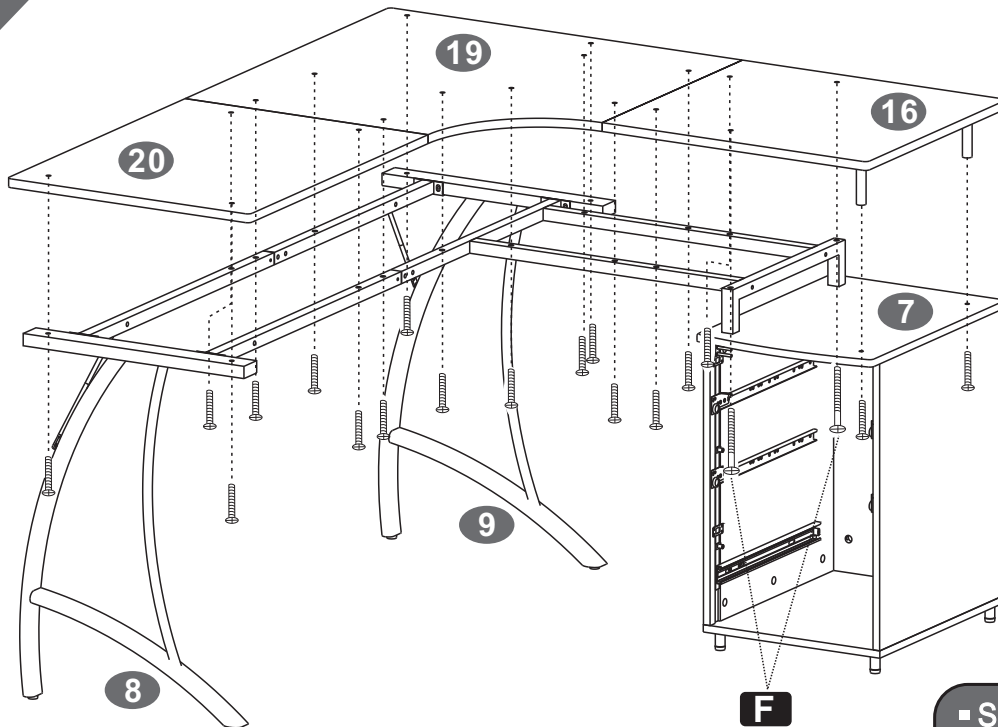

- Assemble the Small Table Panel (16), the Corner Table Panel (19) and the Big Table Panel (20) using Screws (D&F).  
DO NOT TIGHTEN ANY SCREWS UNTILL ALL ARE IN PLACE.  
Please pay attention of the position of the screws.

- *Ensamble el Panel de mesa pequeño (16), Panel de Mesa Esquinero (19), y el Panel de Mesa Grande (20) usando tornillos (D & F).  
NO APRIETE NINGUN TORNILLO HASTA QUE TODOS ESTÉN COLOCADOS.  
Por favor fíjese bien en las posiciones de los tornillos tal como se muestra.*

▪ SCREWS ▪ TORNILLOS

**D** 6X35 MM

18PCS

**F** 6X115 MM

2PCS

B5

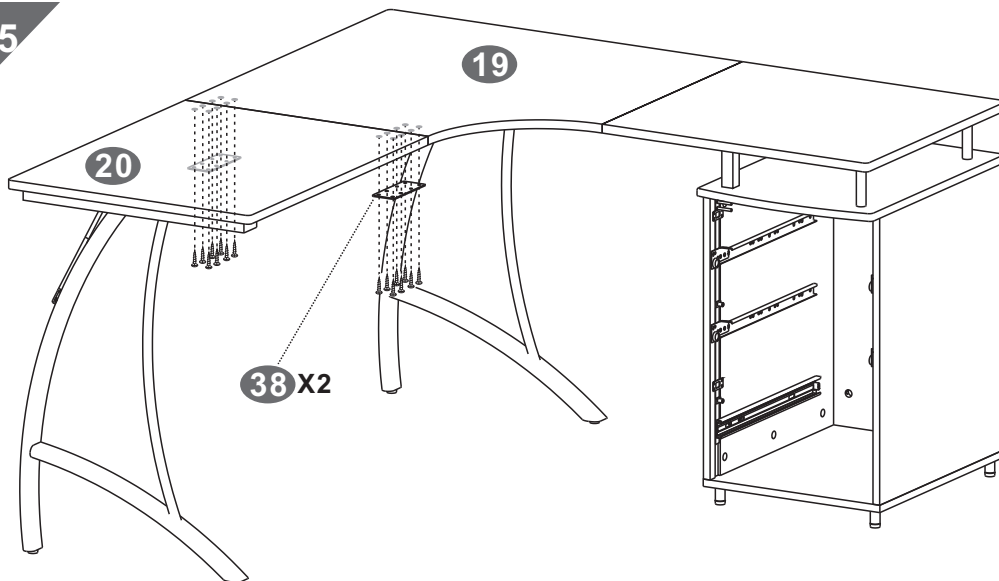

- Assemble the Connect Metal Plates (38) on the bottom and between the Corner Table Panel (19) and the Big Table Panel (20) using Screws (K).

- *Ensamble los Platos Metálico de Conexión (38) por debajo y entre medio del Panel de Mesa Esquinero (19) y el Panel de Mesa Grande (20) usando tornillos (K).*

▪ SCREWS ▪ TORNILLOS

**K** 4X14 MM

16PCS

B6

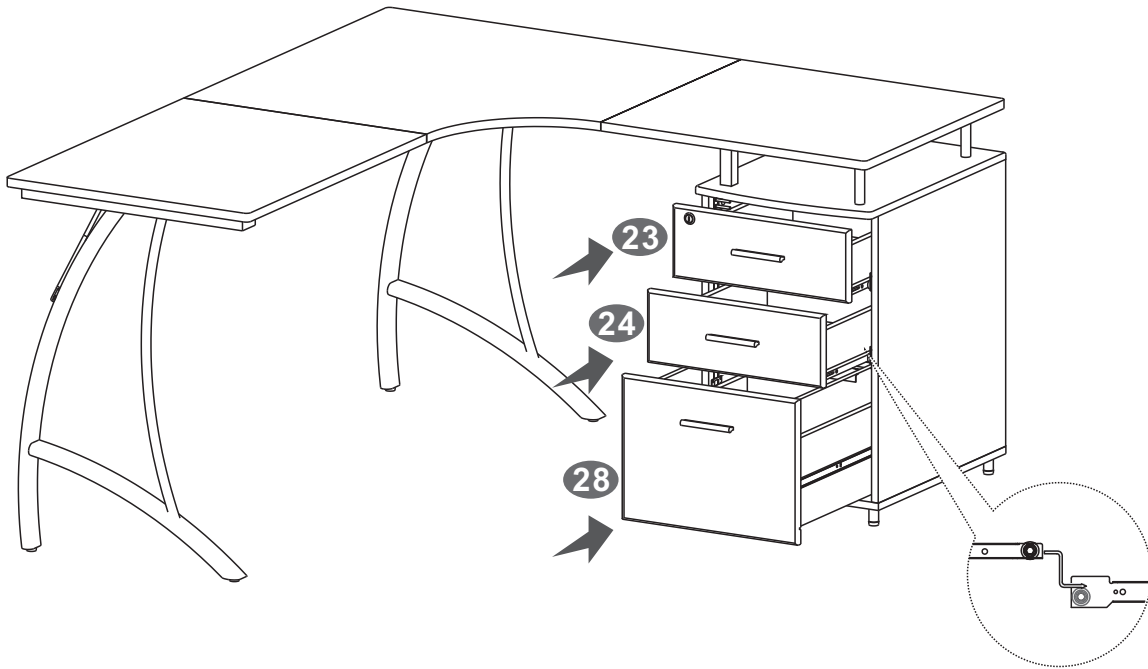

1st

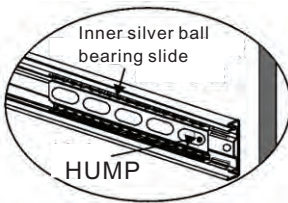

Make sure inner silver ball bearing slide is at the front of the slide mount and in lock position (over the hump), as shown.  
*Asegúrese que las balineras estén hacia el frente como se muestra.*

2nd

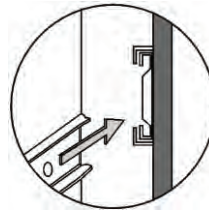

Align both sides of slide runners to slide mounts' openings, then slide all the way in. Apply small force to insert completely if needed.  
*Alinee los deslizadores en ambos lados y deslice lenta y firmemente. Aplique un poco de fuerza si fuera necesario.*

- Carefully slide drawers onto rails and push firmly and evenly until they are completely closed.
- *Deslice firme pero cuidadosamente las gavetas hasta que queden completamente cerradas.*

B7

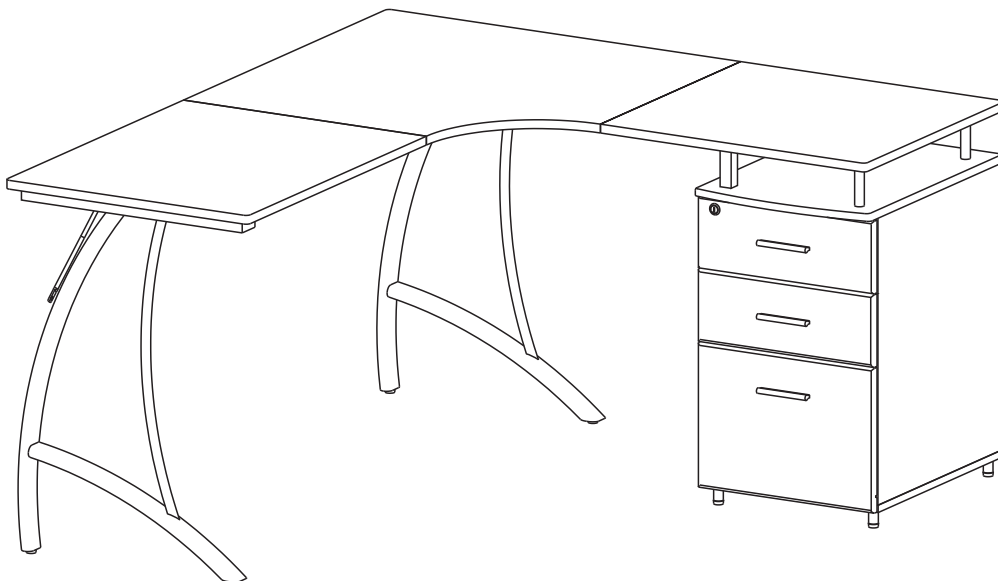

# CARE AND MAINTENANCE

## English

- DO NOT EXPOSE THE SURFACES TO DIRECT SUNLIGHT, OR EXTREME ENVIRONMENTAL CONDITIONS. EXPOSURE WILL DAMAGE THE PRODUCT, WHICH IS NOT COVERED BY THE WARRANTY.
- DO NOT USE SOLVENTS OVER SURFACES OR STRUCTURAL TUBES. SURFACES MUST BE CLEANED WITH A SOLUTION OF A SMOOTH SOAP AND WATER, THEN CLEARED WITH A DRY TOWEL.
- PRODUCTS THAT ARE HEAVY SHOULD BE LIFTED OR MOVED BY AT LEAST 2 PERSONS, AND ALL OBJECTS SHOULD BE REMOVED FROM THE PRODUCT.

## Spanish

- NO EXPONGA LAS SUPERFICIES A LA LUZ SOLAR DIRECTA, O A CONDICIONES AMBIENTALES EXTREMAS. ESTE TIPO DE DAÑOS NO SON CUBIERTOS POR LA GARANTÍA DEL PRODUCTO.
- NO USE SOLVENTES SOBRE LAS SUPERFICIES O TUBOS ESTRUCTURALES. LAS SUPERFICIES DEBEN SER LIMPIADOS CON UN JABÓN SUAVE Y AGUA, Y SECADOS INMEDIATAMENTE CON UNA TOALLA LIMPIA Y SECA.
- PRODUCTOS QUE SON PESADOS DEBEN LEVANTARSE O MOVERSE POR AL MENOS 2 PERSONAS, Y TODOS LOS OBJETOS DEBEN SER REMOVIDOS DEL PRODUCTO.