

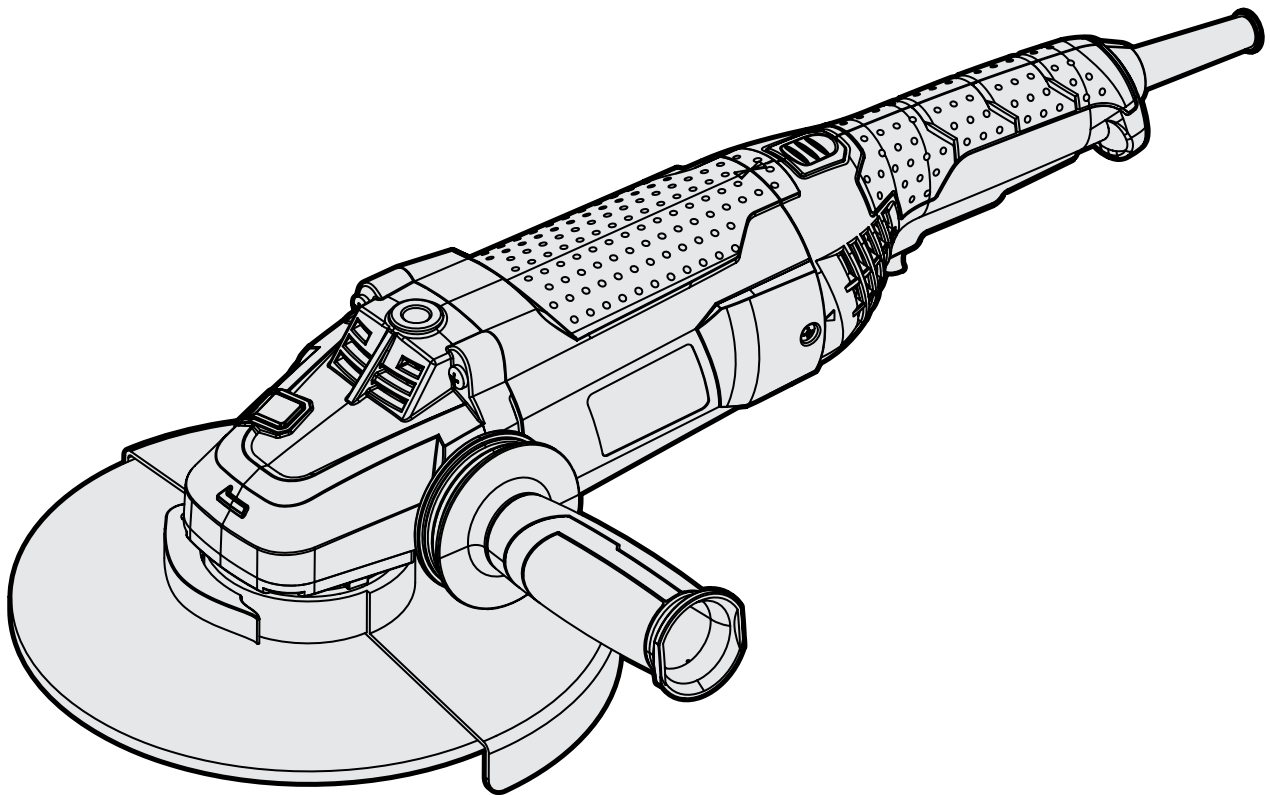

MODEL 94487

7-INCH ANGLE GRINDER

Instruction Manual



NEED HELP? CONTACT US!

Have product questions? Need technical support? Please feel free to contact us:



1-847-429-9263 (M-F 8AM-5PM CST)



TECHSUPPORT@WENPRODUCTS.COM

IMPORTANT: Your new tool has been engineered and manufactured to WEN's highest standards for dependability, ease of operation, and operator safety. When properly cared for, this product will supply you years of rugged, trouble-free performance. Pay close attention to the rules for safe operation, warnings, and cautions. If you use your tool properly and for its intended purpose, you will enjoy years of safe, reliable service.

For replacement parts and the most up-to-date instruction manuals, visit ***WENPRODUCTS.COM***

CONTENTS

WELCOME	3
Introduction	3
Specifications.....	3
SAFETY	4
General Safety Rules.....	4
Angle Grinder Safety Warnings	6
Electrical Information.....	8
BEFORE OPERATING	9
Unpacking & Packing List.....	9
Know Your Angle Grinder.....	9
Assembly & Adjustments.....	10
OPERATION & MAINTENANCE	11
Operation	11
Maintenance.....	13
Exploded View & Parts List.....	14
Warranty Statement.....	16

To purchase accessories and replacement parts for your tool, visit **WENPRODUCTS.COM**

INTRODUCTION

Thanks for purchasing the WEN Angle Grinder. We know you are excited to put your tool to work, but first, please take a moment to read through the manual. Safe operation of this tool requires that you read and understand this operator's manual and all the labels affixed to the tool. This manual provides information regarding potential safety concerns, as well as helpful assembly and operating instructions for your tool.

 Indicates danger, warning, or caution. The safety symbols and the explanations with them deserve your careful attention and understanding. Always follow the safety precautions to reduce the risk of fire, electric shock or personal injury. However, please note that these instructions and warnings are not substitutes for proper accident prevention measures.

NOTE: The following safety information is not meant to cover all possible conditions and situations that may occur. WEN reserves the right to change this product and specifications at any time without prior notice.

At WEN, we are continuously improving our products. If you find that your tool does not exactly match this manual, please visit wenproducts.com for the most up-to-date manual or contact our customer service at **1-847-429-9263**.

Keep this manual available to all users during the entire life of the tool and review it frequently to maximize safety for both yourself and others.

SPECIFICATIONS

Model Number	94487
Motor	120V, 60 Hz, 15A
Speed	8400 RPM
Disc Size	7 in. (180mm)
Arbor Size	5/8"-11 UNC
Inner Flange Adapter Size	1.6 in. (40mm) Diameter
Power Cord Length	6 ft.
Product Weight	10.8 lbs
Product Dimensions	18.1 in. x 3.9 in. x 6.7 in.

GENERAL SAFETY RULES

 **WARNING!** Read all safety warnings and all instructions. Failure to follow the warnings and instructions may result in electric shock, fire and/or serious injury.

Safety is a combination of common sense, staying alert and knowing how your item works. The term “power tool” in the warnings refers to your mains-operated (corded) power tool or battery-operated (cordless) power tool.

SAVE THESE SAFETY INSTRUCTIONS.

WORK AREA SAFETY

- 1. Keep work area clean and well lit.** Cluttered or dark areas invite accidents.
- 2. Do not operate power tools in explosive atmospheres, such as in the presence of flammable liquids, gases or dust.** Power tools create sparks which may ignite the dust or fumes.
- 3. Keep children and bystanders away while operating a power tool.** Distractions can cause you to lose control.

ELECTRICAL SAFETY

- 1. Power tool plugs must match the outlet. Never modify the plug in any way. Do not use any adapter plugs with earthed (grounded) power tools.** Unmodified plugs and matching outlets will reduce risk of electric shock.
- 2. Avoid body contact with earthed or grounded surfaces such as pipes, radiators, ranges and refrigerators.** There is an increased risk of electric shock if your body is earthed or grounded.
- 3. Do not expose power tools to rain or wet conditions.** Water entering a power tool will increase the risk of electric shock.
- 4. Do not abuse the cord. Never use the cord for carrying, pulling or unplugging the power tool. Keep cord away from heat, oil, sharp edges or moving parts.** Damaged or entangled cords increase the risk of electric shock.
- 5. When operating a power tool outdoors, use an extension cord suitable for outdoor use.** Use of a cord suitable for outdoor use reduces the risk of electric shock.

6. If operating a power tool in a damp location is unavoidable, use a ground fault circuit interrupter (GFCI) protected supply. Use of a GFCI reduces the risk of electric shock.

PERSONAL SAFETY

- 1. Stay alert, watch what you are doing and use common sense when operating a power tool. Do not use a power tool while you are tired or under the influence of drugs, alcohol or medication.** A moment of inattention while operating power tools may result in serious personal injury.
- 2. Use personal protective equipment. Always wear eye protection.** Protective equipment such as a respiratory mask, non-skid safety shoes and hearing protection used for appropriate conditions will reduce the risk of personal injury.
- 3. Prevent unintentional starting. Ensure the switch is in the off-position before connecting to power source and/or battery pack, picking up or carrying the tool.** Carrying power tools with your finger on the switch or energizing power tools that have the switch on invites accidents.
- 4. Remove any adjusting key or wrench before turning the power tool on.** A wrench or a key left attached to a rotating part of the power tool may result in personal injury.
- 5. Do not overreach. Keep proper footing and balance at all times.** This enables better control of the power tool in unexpected situations.
- 6. Dress properly. Do not wear loose clothing or jewelry. Keep your hair and clothing away from moving parts.** Loose clothes, jewelry or long hair can be caught in moving parts.

GENERAL SAFETY RULES

 **WARNING!** Read all safety warnings and all instructions. Failure to follow the warnings and instructions may result in electric shock, fire and/or serious injury.

Safety is a combination of common sense, staying alert and knowing how your item works. The term “power tool” in the warnings refers to your mains-operated (corded) power tool or battery-operated (cordless) power tool.

SAVE THESE SAFETY INSTRUCTIONS.

7. If devices are provided for the connection of dust extraction and collection facilities, ensure these are connected and properly used. Use of dust collection can reduce dust-related hazards.

POWER TOOL USE AND CARE

1. Do not force the power tool. Use the correct power tool for your application. The correct power tool will do the job better and safer at the rate for which it was designed.

2. Do not use the power tool if the switch does not turn it on and off. Any power tool that cannot be controlled with the switch is dangerous and must be repaired.

3. Disconnect the plug from the power source and/or the battery pack from the power tool before making any adjustments, changing accessories, or storing power tools. Such preventive safety measures reduce the risk of starting the power tool accidentally.

4. Store idle power tools out of the reach of children and do not allow persons unfamiliar with the power tool or these instructions to operate the power tool. Power tools are dangerous in the hands of untrained users.

5. Maintain power tools. Check for misalignment or binding of moving parts, breakage of parts and any other condition that may affect the power tool's operation. If damaged, have the power tool repaired before use. Many accidents are caused by poorly maintained power tools.

6. Keep cutting tools sharp and clean. Properly maintained cutting tools with sharp cutting edges are less likely to bind and are easier to control.

7. Use the power tool, accessories and tool bits, etc. in accordance with these instructions, taking into account the working conditions and the work to be performed. Use of the power tool for operations different from those intended could result in a hazardous situation.

8. Use clamps to secure your workpiece to a stable surface. Holding a workpiece by hand or using your body to support it may lead to loss of control.

9. KEEP GUARDS IN PLACE and in working order.

SERVICE

1. Have your power tool serviced by a qualified repair person using only identical replacement parts. This will ensure that the safety of the power tool is maintained.

CALIFORNIA PROPOSITION 65 WARNING

Some dust created by power sanding, sawing, grinding, drilling, and other construction activities may contain chemicals, including lead, known to the State of California to cause cancer, birth defects, or other reproductive harm. Wash hands after handling. Some examples of these chemicals are:

- Lead from lead-based paints.
- Crystalline silica from bricks, cement, and other masonry products.
- Arsenic and chromium from chemically treated lumber.

Your risk from these exposures varies depending on how often you do this type of work. To reduce your exposure to these chemicals, work in a well-ventilated area with approved safety equipment such as dust masks specially designed to filter out microscopic particles.

ANGLE GRINDER SAFETY WARNINGS

 **WARNING!** Do not operate the power tool until you have read and understood the following instructions and the warning labels.

ANGLE GRINDER SAFETY

1. Tool purpose. This power tool is intended to function as a grinder and sander. Using the tool for operations for which it was not designed may create a hazard and cause personal injury.

2. Work environment. Do not operate the tool in wet or damp conditions; doing so significantly increases the risk of electrical shock. Do not operate the tool in the presence of flammable liquids or gases; sparks generated by the grinder could ignite these flammable materials.

3. Personal Safety. Always wear ANSI Z87.1-approved glasses with side shields, hearing protection and a dust mask when using the angle grinder. Tie back long hair. Do not wear loose clothing or jewelry as they might get drawn in by the tool.

4. Tool and accessory inspection. Before operation, check the tool and accessories for any damage or missing parts. Do not use the tool if any part is missing or damaged. Make sure all adjustments are correct and all connections are tight. Keep all guards in place.

5. Preventing electric shock. Hold your power tool by the insulated gripping surfaces, especially when performing an operation where the accessory could contact hidden wiring or its own cord. Contact with a “live” wire will make exposed metal parts of the tool “live” and shock the operator. Always be aware of power cord location to avoid accidentally contacting the power cord.

6. Use the right grinding wheel for your tool and the workpiece.

- The rated speed of the accessory must be equal to or higher than the operation speed (8000 RPM) of the angle grinder. Accessories running faster than the rated speed can fly apart and cause injury.

- Use grinding wheels with 7 inch outer diameter and a 5/8"-11 threaded arbor or 7/8 inch unthreaded arbor. The grinding wheel thickness should not exceed 1/4 inch. Incorrectly sized accessories cannot be adequately guarded or controlled.

7. Securing the workpiece. Secure any loose workpieces using vises or clamps to prevent wobble, damage to the workpiece, and personal injury.

8. Starting the tool. Hold the tool with both hands in front and away from you. Do not run the tool while carrying it at your side. Start the angle grinder before applying it to the workpiece. Let the wheel come to full speed before contacting the workpiece.

9. During operation. To prevent personal injury, maintain a firm grip on the tool with both hands. Keep hands, hair and other beloved body parts away from the rotating components of the tool.

10. Turning off the tool. Lift the tool from the workpiece before turning the machine off. Do not lay the tool down until it has come to a complete stop. Do not touch the pad or the workpiece immediately after operation. They may be extremely hot and could burn your skin.

11. Making adjustments. Always turn off and unplug the grinder before cleaning, making adjustments or changing attachments. Accidental start-ups may occur if the tool is plugged in during an accessory change or adjustment.

12. Cleaning after use. Blow off the motor vents and power switch after every use, using compressed air (not to exceed 25 PSI). Failure to do so can lead to buildup of grinding debris and dust, possibly leading to motor or switch failure.

ANGLE GRINDER SAFETY WARNINGS

 **WARNING!** Do not operate the power tool until you have read and understood the following instructions and the warning labels.

REDUCING KICKBACK

Kickback is a sudden reaction to a pinched or snagged rotating grinding wheel or any other accessory. Pinching or snagging causes rapid stalling of the rotating accessory which in turn causes the uncontrolled power tool to be jump toward or away from the operator, depending on direction of the wheel's movement at the point of pinching. Take proper safety prevention methods to reduce the risk of kickback:

1. Maintain a firm grip on the power tool and position your body and arm to allow you to resist kickback forces. Always use the auxiliary handle for maximum control over kickback or torque reaction during start-up. The operator can control torque reactions or kickback forces, if proper precautions are taken.
2. Never place your hand near the rotating accessory. Accessories may kick back over your hand.
3. Do not position your body in the area where power tool will move if kickback occurs. Kickback will propel the tool in direction opposite to the wheel's movement at the point of snagging.
4. Use special care when working corners, sharp edges etc. Avoid bouncing and snagging the accessory. Corners, sharp edges or bouncing have a tendency to snag the rotating accessory and cause loss of control or kickback.

VIBRATION SAFETY

This tool vibrates during use. Repeated or long-term exposure to vibration may cause temporary or permanent physical injury, particularly to the hands, arms and shoulders. To reduce the risk of any vibration-related injury:

1. First be examined by a doctor and then have regular medical check-ups to ensure medical problems are not being caused or worsened from use. Pregnant women or people who have impaired blood circulation to the hand, past hand injuries, nervous system disorders, diabetes, or Raynaud's disease should not use this tool. If you feel any symptoms related to vibration (such as tingling, numbness, and white or blue fingers), seek medical advice as soon as possible.
2. Do not smoke during use. Nicotine reduces the blood supply to the hands and fingers, increasing the risk of vibration-related injury.
3. Wear suitable gloves to reduce the effects of vibration.
4. Use tools with the lowest vibration when there is a choice.
5. Take vibration-free breaks during each day of work.
6. To reduce vibration, maintain the tool as explained in this manual. If any abnormal vibration occurs, stop using the tool immediately.

ELECTRICAL INFORMATION

DOUBLE-INSULATED TOOL

The tool's electrical system is double-insulated where two systems of insulation are provided. This eliminates the need for the usual three-wire grounded power cord. Double-insulated tools do not need to be grounded, nor should a means for grounding be added to the product. All exposed metal parts are isolated from the internal metal components with protecting insulation.

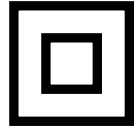

IMPORTANT: Servicing a double-insulated product requires extreme care and knowledge of the system, and should be done only by qualified service personnel using identical replacement parts. Always use original factory replacement parts when servicing.

1. Polarized Plugs. To reduce the risk of electric shock, this equipment has a polarized plug (one blade is wider than the other). This plug will fit in a polarized outlet only one way. If the plug does not fit fully in the outlet, reverse the plug. If it still does not fit, contact a qualified electrician to install a proper outlet. Do not modify the machine plug or the extension cord in any way.

2. Ground fault circuit interrupter protection (GFCI) should be provided on the circuit or outlet used for this power tool to reduce the risk of electric shock.

3. Service and repair. To avoid danger, electrical appliances must only be repaired by a qualified service technician using original replacement parts.

GUIDELINES AND RECOMMENDATIONS FOR EXTENSION CORDS

When using an extension cord, be sure to use one heavy enough to carry the current your product will draw. An undersized cord will cause a drop in line voltage, resulting in loss of power and overheating. The table below shows the correct size to be used according to cord length and ampere rating. When in doubt, use a heavier cord. The smaller the gauge number, the heavier the cord.

AMPERAGE	REQUIRED GAUGE FOR EXTENSION CORDS			
	25 ft.	50 ft.	100 ft.	150 ft.
15A	14 gauge	12 gauge	Not Recommended	

1. Examine extension cord before use. Make sure your extension cord is properly wired and in good condition. Always replace a damaged extension cord or have it repaired by a qualified person before using it.

2. Do not abuse extension cord. Do not pull on cord to disconnect from receptacle; always disconnect by pulling on plug. Disconnect the extension cord from the receptacle before disconnecting the product from the extension cord. Protect your extension cords from sharp objects, excessive heat and damp/wet areas.

3. Use a separate electrical circuit for your tool. This circuit must not be less than a 12-gauge wire and should be protected with a 15A time-delayed fuse. Before connecting the motor to the power line, make sure the switch is in the OFF position and the electric current is rated the same as the current stamped on the motor nameplate. Running at a lower voltage will damage the motor.

UNPACKING & PACKING LIST

UNPACKING

Carefully remove the angle grinder from the packaging and place it on a sturdy, flat surface. Make sure to take out all contents and accessories. Do not discard the packaging until everything is removed. Check the packing list below to make sure you have all of the parts and accessories. If any part is missing or broken, please contact customer service at **1-847-429-9263** (M-F 8-5 CST), or email techsupport@wenproducts.com.

PACKING LIST

Description	Quantity
Angle Grinder	1
7-Inch Grinding Disc	1
Disc Guard	1
Auxiliary Handle	1
Lock Nut Wrench	1
Pair of Carbon Brushes	1

KNOW YOUR ANGLE GRINDER

TOOL PURPOSE

Grind metal, cut tile, sand, polish and sharpen all with your WEN Angle Grinder. Refer to the following diagrams to become familiarized with all the parts and controls of your angle grinder. The components will be referred to later in the manual for assembly and operation instructions.

Power Cord

Angle Adjustment Lock

Threaded Handle Hole

Power Trigger

Trigger Lock

Spindle Lock

Directional Arrow

Auxiliary Handle

Grinding Disc Cover

Grinding Disc

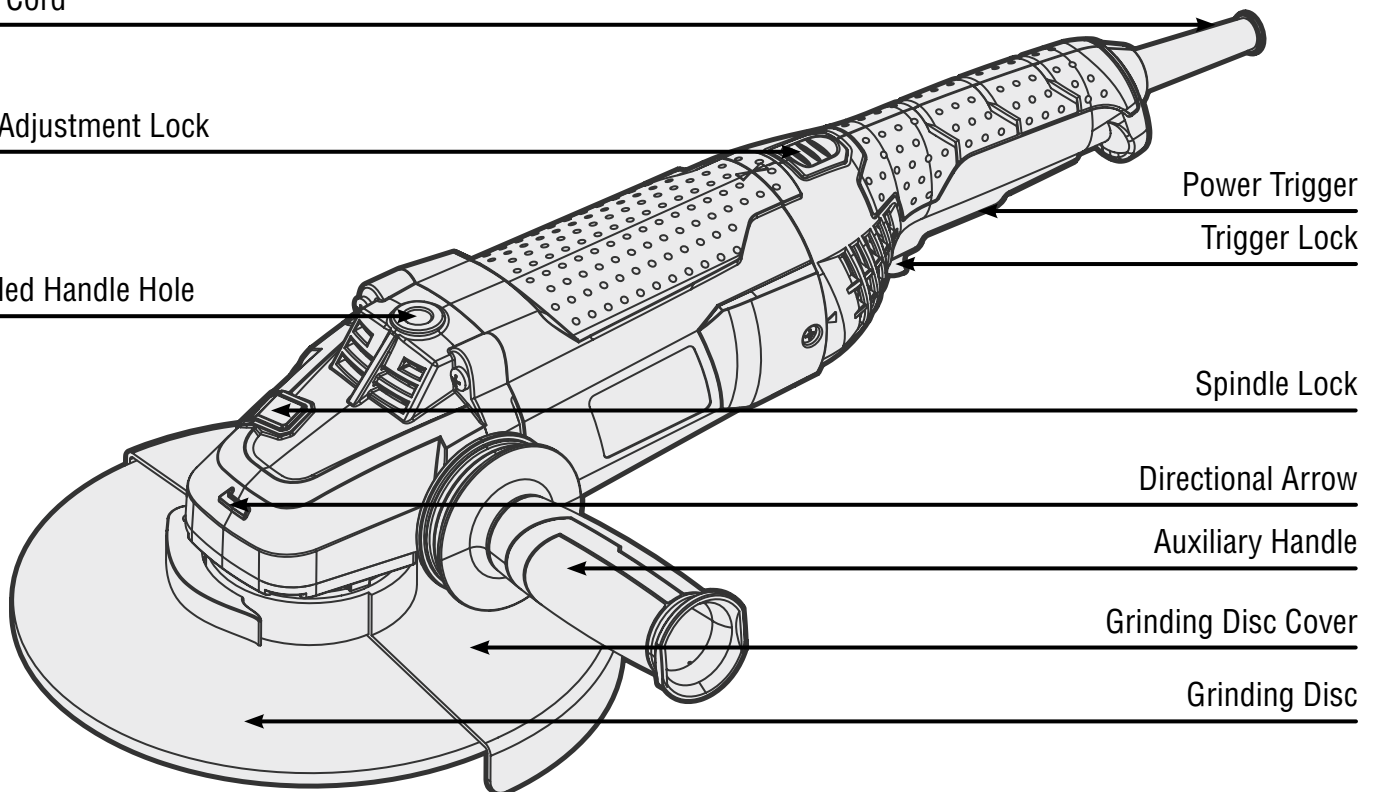

ASSEMBLY & ADJUSTMENTS

⚠ WARNING! To avoid injury from accidental startups, make sure that the tool is OFF and removed from the power supply when assembling the tool or when making any adjustments.

WHEEL GUARD INSTALLATION

⚠ WARNING! Use the wheel guard with disc grinding wheels. Always close the locking handle to secure the guard. Keep the guard between you and the wheel. Do not direct the guard opening toward your body.

The position of the guard can be adjusted to accommodate the operation being performed.

1. Make sure that the tool is OFF and removed from the power supply before installing the wheel guard.
2. Loosen the guard locking handle (Fig. 1 - 1) and position the guard on to the spindle neck so that the bump on the guard lines up between the notches on the spindle neck.
3. Rotate the guard in either direction to the desired position. Lock the guard locking handle to secure the guard in place.

INSTALLING & REMOVING THE GRINDING DISC

1. Turn the tool OFF and remove it from the power supply. Make sure that the wheel guard (Fig. 2 - 1) has been properly installed before assembling the grinding disc.
 2. Place the inner flange (Fig. 2 - 2) onto the spindle first so that the grooves align with the spindle nut.
 3. Slide the grinding disc (Fig. 2 - 3) onto the spindle.
- NOTE:** You may use an accessory with either a threaded arbor (diameter 5/8"-11) or an unthreaded arbor (diameter 7/8"). If using an accessory with an unthreaded 7/8" arbor, be sure it sits properly on the inner flange before installing the outer flange.
4. Screw the outer flange (Fig. 2 - 4) in place with the protruding lip facing downwards. This lip should fit snugly into the center of the grinding wheel. Tighten the outer flange in place using the supplied lock nut wrench (Fig. 2 - 5) while pressing down on the spindle lock (Fig. 3 - 1) to keep the spindle from rotating.

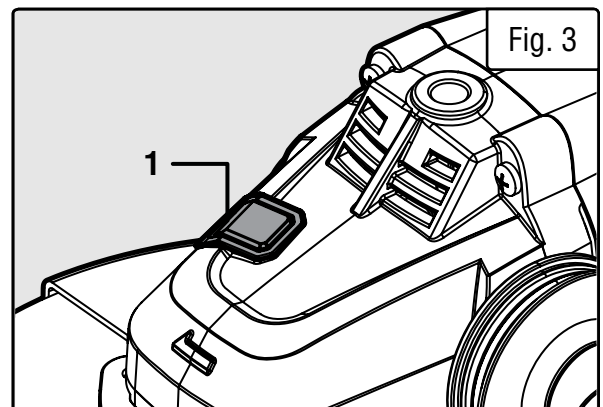
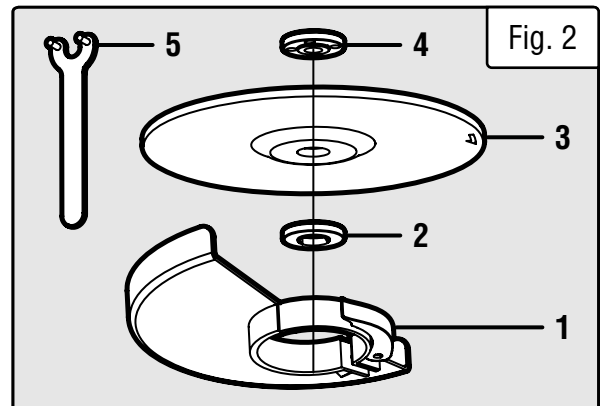
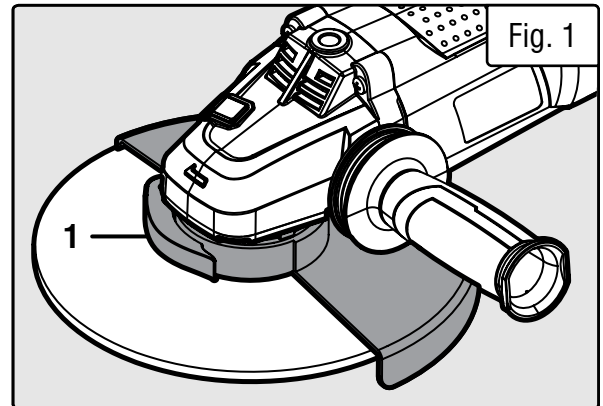

ASSEMBLY & ADJUSTMENTS

⚠ WARNING! To avoid injury from accidental startups, make sure that the tool is OFF and removed from the power supply when assembling the tool or when making any adjustments.

INSTALLING THE AUXILIARY HANDLE

The auxiliary handle can be installed in one of three different positions: The left side of the housing, the right side of the housing, or on top of the housing.

1. Screw the threaded end of the auxiliary handle (Fig. 4 - 1) into the desired mounting hole. Make sure that the auxiliary handle is secure before beginning operation.

ADJUSTING THE GRINDING ANGLE

The head of your angle grinder can be adjusted to three different angles for different operations: 0°, 90° Left, or 90° Right.

1. Press the angle adjustment lock (Fig. 5 - 1) to unlock the adjustable head.

2. Rotate the angle grinder head (Fig. 5 - 2) left or right until the indication arrow on the head aligns with one of the three indication arrows on the body. The angle grinder head will lock in place. Make sure that the angle grinder head is secure before beginning operation.

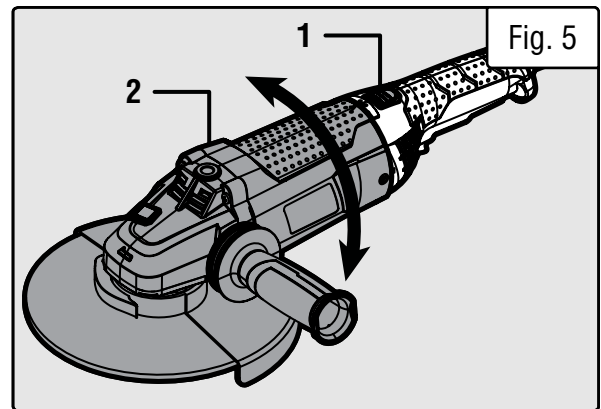
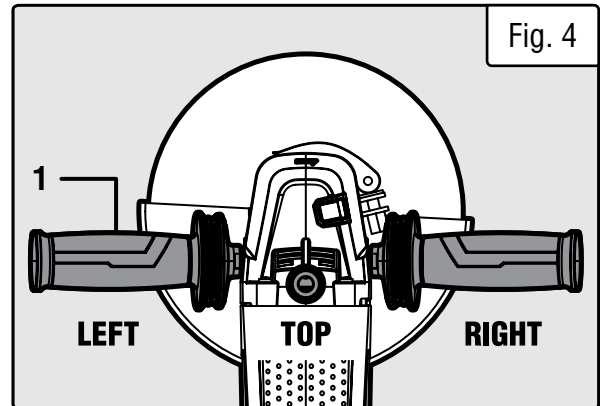

OPERATION

TURNING THE TOOL ON & OFF

⚠ WARNING! DO NOT TURN THE ANGLE GRINDER ON OR OFF WHILE THE TOOL IS UNDER LOAD; this will greatly decrease the life of the tool.

1. Plug the tool into the power supply.

2. To turn the tool ON, push the trigger lock (Fig. 6 - 1) forward. With the trigger lock pushed forward, press the power trigger (Fig. 6 - 2).

3. To turn the tool OFF, release the power trigger and push the trigger lock backward to lock the power trigger in the OFF position.

4. Once operation has been completed, unplug the tool from the power supply.

Always hold the tool with both hands since the torque from the motor can cause the grinder to twist. Start the angle grinder before applying it to the workpiece. Allow the disc to reach full speed before making contact with the workpiece. Lift the tool from the workpiece before turning the machine OFF.

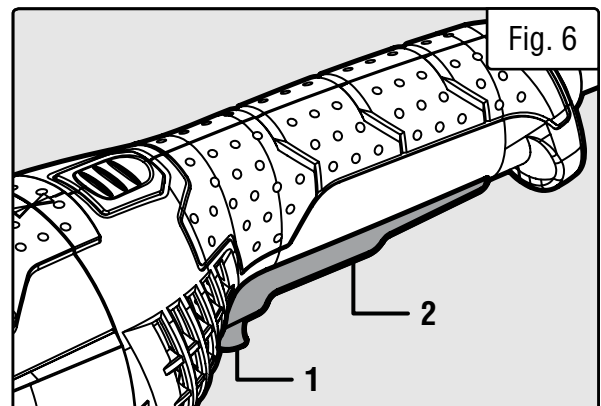

OPERATION

SELECTING THE GRINDING DISC

Before using a grinding wheel, make sure that its maximum safe operating speed is more than 8,500 RPM. Do not exceed the recommended wheel diameter. Make sure it has a threaded 5/8"-11 arbor, or an unthreaded 7/8" arbor to fit the supplied inner flange.

Grinding wheels should be carefully selected in order to maximize efficiency. Wheels vary in abrasiveness, bond, harness, grit size and structure. The correct type of wheel to use is determined by the job at hand. Use disc grinding wheels for fast grinding of structural steel, heavy weld beads, steel casting, stainless steel and other ferrous metals.

GRINDING TIPS

Efficient grinding is achieved by controlling the pressure and keeping the angle between the wheel and the workpiece between 15° to 30°. If the wheel is flat, the tool will be difficult to control. If the angle is too steep, the pressure concentrated on a small area can cause burning to the work surface.

WARNING! - Excessive or sudden pressure on the wheel will slow the grinding action and put dangerous stresses on the wheel.

When grinding with a new wheel, be sure to grind while pulling the tool backwards until the wheel becomes rounded on its edge. New wheels have sharp corners which tend to "bite" or cut into the workpiece when pushing forward.

 **WARNING!** Excessive or sudden pressure on the wheel will slow the grinding action and put dangerous stresses on the wheel.

MAINTENANCE

⚠ WARNING! To avoid accidents, make sure the tool is OFF and removed from the power supply before cleaning or performing any maintenance. Servicing of the tool must be performed by a qualified technician.

REPLACING THE CARBON BRUSHES

To maintain maximum efficiency of the motor, we recommend changing the carbon brushes every 50 hours of operation. Replacement carbon brushes (**part no. 94487-038**) are available at **wenproducts.com**. Only genuine WEN replacement brushes designed specifically for your tool should be used.

Your angle grinder comes with one pair of replacement carbon brushes.

To inspect or replace the carbon brushes:

1. Loosen the four gear box housing screws (Fig. 6 - 1) and remove the gear box housing.
2. When removing the carbon brushes (Fig. 6 - 2), take note of their orientation. The new carbon brushes will need to be installed in the same orientation.

NOTE: Both carbon brushes should be replaced at the same time.

3. Install the new carbon brushes and replace the gear box housing cover.
4. Once the new carbon brushes have been installed, run the angle grinder to make sure that the brushes have been installed correctly.

NOTE: It is normal for new carbon brushes to spark a bit as they wear in.

PRODUCT DISPOSAL

Used power tools should not be disposed of together with household waste. This product contains electronic components that should be recycled. Please take this product to your local recycling facility for responsible disposal and to minimize its environmental impact.

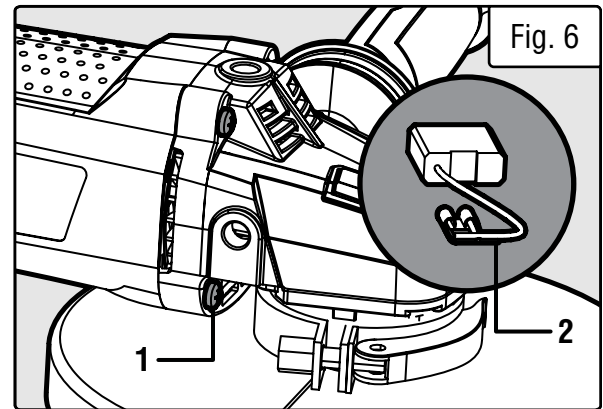

ROUTINE INSPECTION

1. Before each use, inspect the general condition of the tool.

Check for:

- Loose hardware
- Misalignment or binding of moving parts
- Damaged cord/electrical wiring
- Cracked or broken parts
- Any other condition that may affect its safe operation

2. After every use, wipe the tool with a soft cloth. Do not let water enter the tool.

3. Keep the ventilation openings and power switch free from dust and debris to prevent the motor from overheating or switch from failing. Blow the tool off using compressed air (not to exceed 25 PSI) after every use.

4. Most plastics are susceptible to damage from various types of commercial solvents. Do not use any solvents or cleaning products that could damage the plastic parts. Some of these include but are not limited to: gasoline, carbon tetrachloride, chlorinated cleaning solvents, ammonia and household detergents that contain ammonia.

5. Store the tool in a clean and dry place away from the reach of children.

EXPLODED VIEW & PARTS LIST

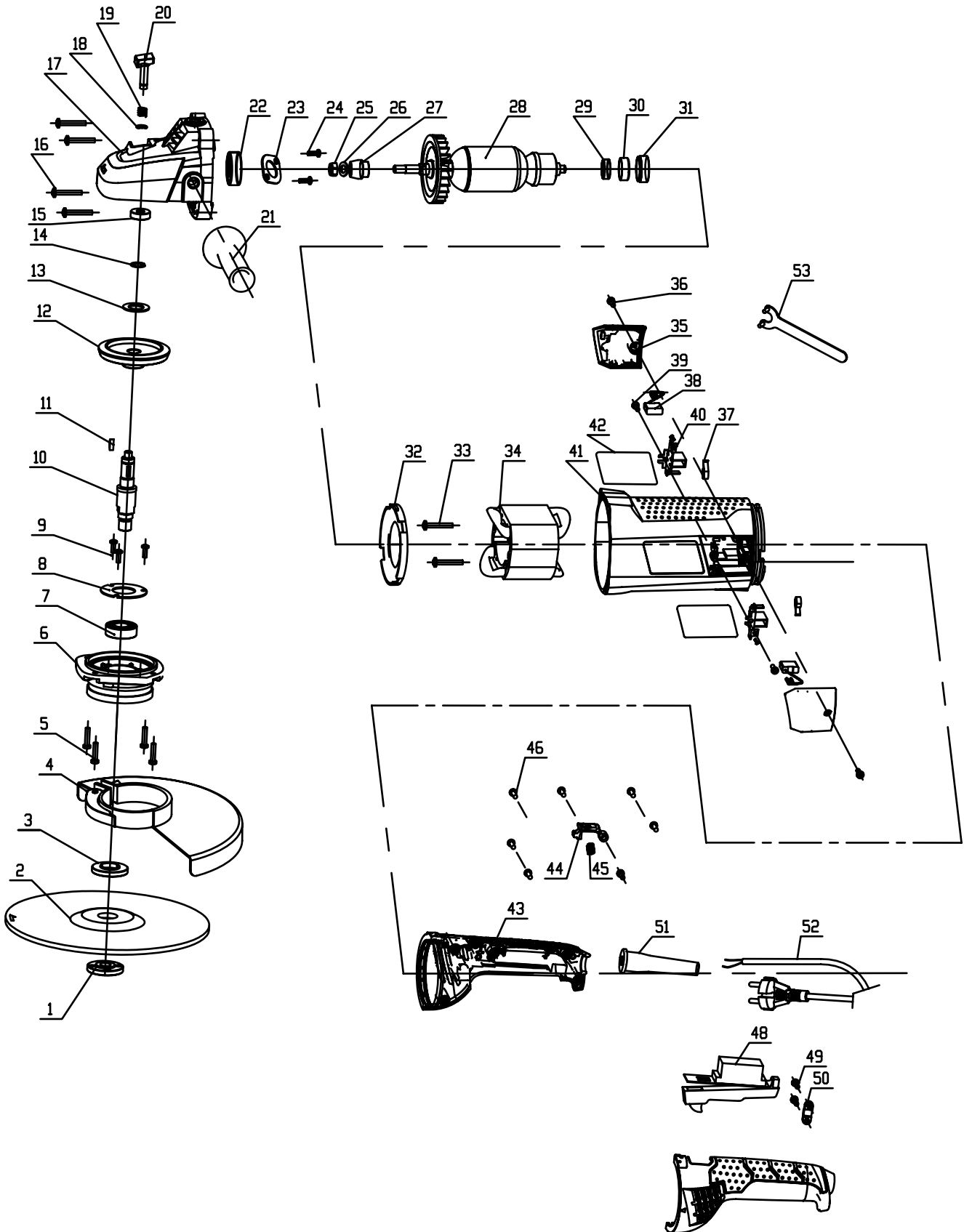

NOTE: Not all parts may be available for purchase. Parts and accessories that wear down over the course of normal use are not covered under the warranty.

EXPLODED VIEW & PARTS LIST

No.	Part No.	Description	Qty.	No.	Part No.	Description	Qty.
1	94487-001	Outer Flange	1	27	94487-027	Pinion	1
2	94487-002	Grinding Disc	1	28	94487-028	Rotor	1
3	94487-003	Inner Flange	1	29	94487-029	Bearing 608	1
4	94487-004	Wheel Guard Assembly	1	30	94487-030	Bearing Cover	1
5	94487-005	Screw M5x16	4	31	94487-031	Bearing Seat	1
6	94487-006	Gearing Cover	1	32	94487-032	Wind Shield	1
7	94487-007	Bearing 6202	1	33	94487-033	Screw ST 3.9x60	2
8	94487-008	Bearing Cover	1	34	94487-034	Stator	1
9	94487-009	Screw M4x10	3	35	94487-035	Brush Cover	2
10	94487-010	Spindle	1	36	94487-036	Screw ST 3.9X16	2
11	94487-011	Half Key (4x13)	1	37	94487-037	Spring	2
12	94487-012	Large Gear	1	38	94487-038	Carbon Brush	2
13	94487-013	Wave Washer	1	39	94487-039	Screw ST 3.9X16	2
14	94487-014	Spring Washer	1	40	94487-040	Brush Holder	2
15	94487-015	Bearing 608	1	40	94487-041	Screw M4x8	2
16	94487-016	Screw ST4.8x30	4	41	94487-042	Housing	1
17	94487-017	Gear Box Housing	1	42	94487-043	Label	2
18	94487-018	Circlip	1	43	94487-044	Bottom Handle	1
19	94487-019	Spring	1	44	94487-045	Handle Rotation Button	1
20	94487-020	Spindle Lock	1	45	94487-046	Spring ϕ 0.8	1
21	94487-021	Side Handle	1	46	94487-047	Screw ST 3.9x16	5
22	94487-022	Bearing 6001	1	47	94487-048	Switch	1
23	94487-023	Bearing Cover	1	48	94487-049	Screw ST 3.9x16	2
24	94487-024	Screw M4x10	2	49	94487-050	Cable Holder	1
25	94487-025	Locknut M8	1	50	94487-051	Cable Sleeve	1
26	94487-026	Spring Washer	1	51	94487-052	Cable	1
				52	94487-053	Wrench	1

NOTE: Not all parts may be available for purchase. Parts and accessories that wear down over the course of normal use are not covered under the warranty.

WARRANTY STATEMENT

WEN Products is committed to building tools that are dependable for years. Our warranties are consistent with this commitment and our dedication to quality.

LIMITED WARRANTY OF WEN PRODUCTS FOR HOME USE

GREAT LAKES TECHNOLOGIES, LLC (“Seller”) warrants to the original purchaser only, that all WEN consumer power tools will be free from defects in material or workmanship during personal use for a period of two (2) years from date of purchase or 500 hours of use; whichever comes first. Ninety days for all WEN products if the tool is used for professional or commercial use. Purchaser has 30 days from the date of purchase to report missing or damaged parts.

SELLER’S SOLE OBLIGATION AND YOUR EXCLUSIVE REMEDY under this Limited Warranty and, to the extent permitted by law, any warranty or condition implied by law, shall be the replacement of parts, without charge, which are defective in material or workmanship and which have not been subjected to misuse, alteration, careless handling, misrepair, abuse, neglect, normal wear and tear, improper maintenance, or other conditions adversely affecting the Product or the component of the Product, whether by accident or intentionally, by persons other than Seller. To make a claim under this Limited Warranty, you must make sure to keep a copy of your proof of purchase that clearly defines the Date of Purchase (month and year) and the Place of Purchase. Place of Purchase must be a direct vendor of Great Lakes Technologies, LLC. Purchasing through third party vendors, including but not limited to garage sales, pawn shops, resale shops, or any other secondhand merchant, voids the warranty included with this product. Contact techsupport@wenproducts.com or 1-847-429-9263 with the following information to make arrangements: your shipping address, phone number, serial number, required part numbers, and proof of purchase. Damaged or defective parts and products may need to be sent to WEN before the replacements can be shipped out.

Upon the confirmation of a WEN representative, your product may qualify for repairs and service work. When returning a product for warranty service, the shipping charges must be prepaid by the purchaser. The product must be shipped in its original container (or an equivalent), properly packed to withstand the hazards of shipment. The product must be fully insured with a copy of the proof of purchase enclosed. There must also be a description of the problem in order to help our repairs department diagnose and fix the issue. Repairs will be made and the product will be returned and shipped back to the purchaser at no charge for addresses within the contiguous United States.

THIS LIMITED WARRANTY DOES NOT APPLY TO ITEMS THAT WEAR OUT FROM REGULAR USAGE OVER TIME, INCLUDING BELTS, BRUSHES, BLADES, BATTERIES, ETC. ANY IMPLIED WARRANTIES SHALL BE LIMITED IN DURATION TO TWO (2) YEARS FROM DATE OF PURCHASE. SOME STATES IN THE U.S. AND SOME CANADIAN PROVINCES DO NOT ALLOW LIMITATIONS ON HOW LONG AN IMPLIED WARRANTY LASTS, SO THE ABOVE LIMITATION MAY NOT APPLY TO YOU.

IN NO EVENT SHALL SELLER BE LIABLE FOR ANY INCIDENTAL OR CONSEQUENTIAL DAMAGES (INCLUDING BUT NOT LIMITED TO LIABILITY FOR LOSS OF PROFITS) ARISING FROM THE SALE OR USE OF THIS PRODUCT. SOME STATES IN THE U.S. AND SOME CANADIAN PROVINCES DO NOT ALLOW THE EXCLUSION OR LIMITATION OF INCIDENTAL OR CONSEQUENTIAL DAMAGES, SO THE ABOVE LIMITATION OR EXCLUSION MAY NOT APPLY TO YOU.

THIS LIMITED WARRANTY GIVES YOU SPECIFIC LEGAL RIGHTS, AND YOU MAY ALSO HAVE OTHER RIGHTS WHICH VARY FROM STATE TO STATE IN THE U.S., PROVINCE TO PROVINCE IN CANADA AND FROM COUNTRY TO COUNTRY.

THIS LIMITED WARRANTY APPLIES ONLY TO ITEMS SOLD WITHIN THE UNITED STATES OF AMERICA, CANADA AND THE COMMONWEALTH OF PUERTO RICO. FOR WARRANTY COVERAGE WITHIN OTHER COUNTRIES, CONTACT THE WEN CUSTOMER SUPPORT LINE. FOR WARRANTY PARTS OR PRODUCTS REPAIRED UNDER WARRANTY SHIPPING TO ADDRESSES OUTSIDE OF THE CONTIGUOUS UNITED STATES, ADDITIONAL SHIPPING CHARGES MAY APPLY.