

PORTABLE TOOLBOXES

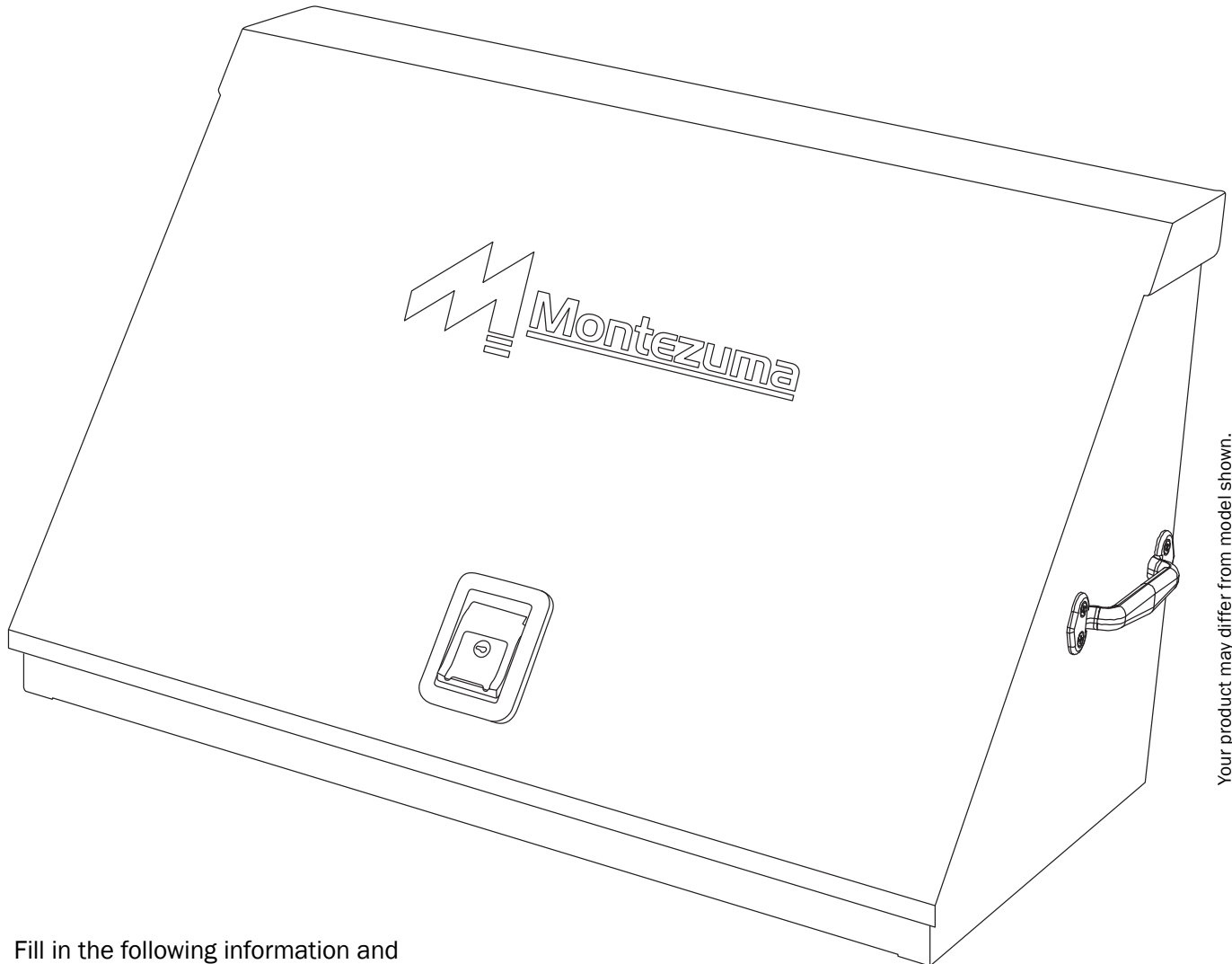

Your product may differ from model shown.

Fill in the following information and retain this manual for future reference:

MODEL(S) _____

DATE OF PURCHASE _____

PLACE OF PURCHASE _____

RECEIPT NO _____

ATTENTION

To reduce the risk of injury, the user must read and understand this instruction manual before using this product for the first time. **SAVE THESE INSTRUCTIONS FOR FUTURE REFERENCE.**

PARTS LISTS

23" X 13" PORTABLE STEEL TOOLBOX



The keys are taped to the top storage area of the chest.

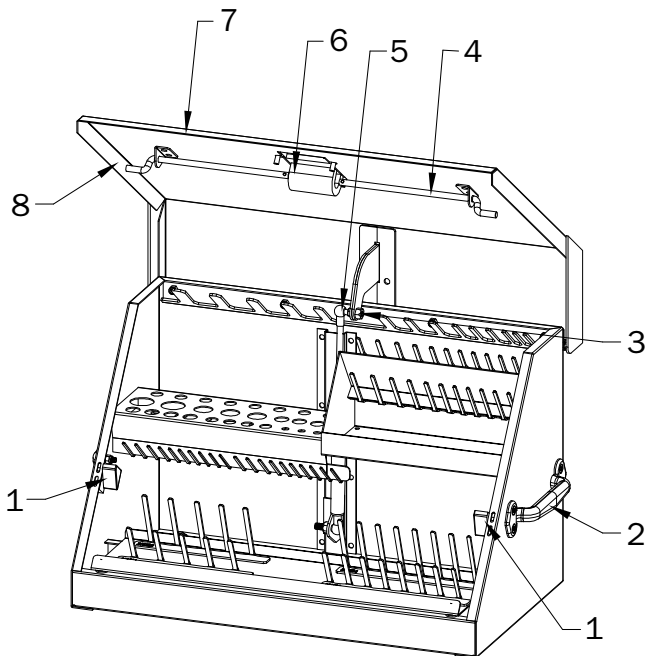

	PART #	DESCRIPTION	QTY
1	304015-304016	Striker Kit Set	1
2	306039	Side Handle	2
3	323000	Lock Nut	2
4	304017	Rod	2
5	303035	Gas Spring	1
6	304042	Latch (801-810)	1
7	314019	585 mm Weatherstripping	1
8	314020	492 mm Weatherstripping	2

26" X 17" PORTABLE STEEL TOOLBOX

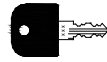

The keys are taped to the top storage area of the chest.

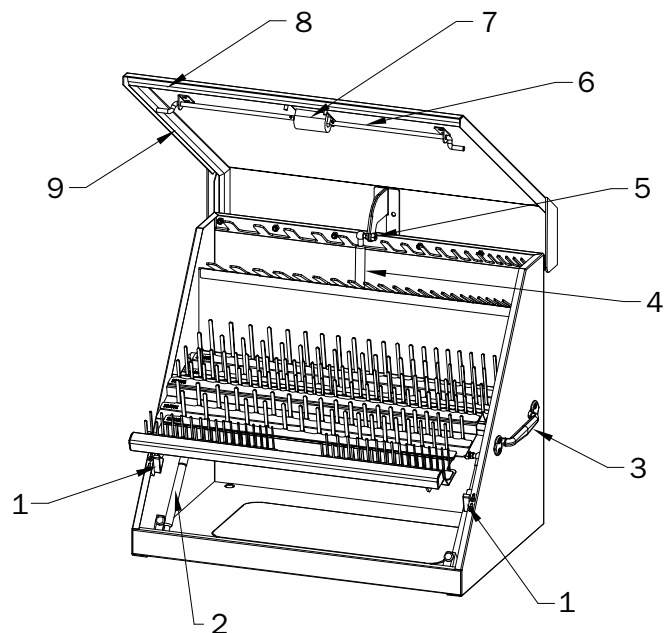

	PART #	DESCRIPTION	QTY
1	304015-304016	Striker Kit Set	1
2	303036	Gas Spring	2
3	306039	Side Handle	2
4	303034	Gas Spring	1
5	323000	Lock Nut	6
6	304018	Rod	2
7	304042	Latch (801-810)	1
8	314029	670 mm Weatherstripping	1
9	314039	697 mm Weatherstripping	2

To order replacement parts, go to www.qualitycraft.com and click on Customer Support. Have the part number and quantity ready. Replacement keys may be ordered using the code that appears on the face of the lock. Not all parts are available under warranty. Those parts not available may be purchased.

26" X 17" PORTABLE STEEL TOOLBOX



The keys are taped to the top storage area of the chest.

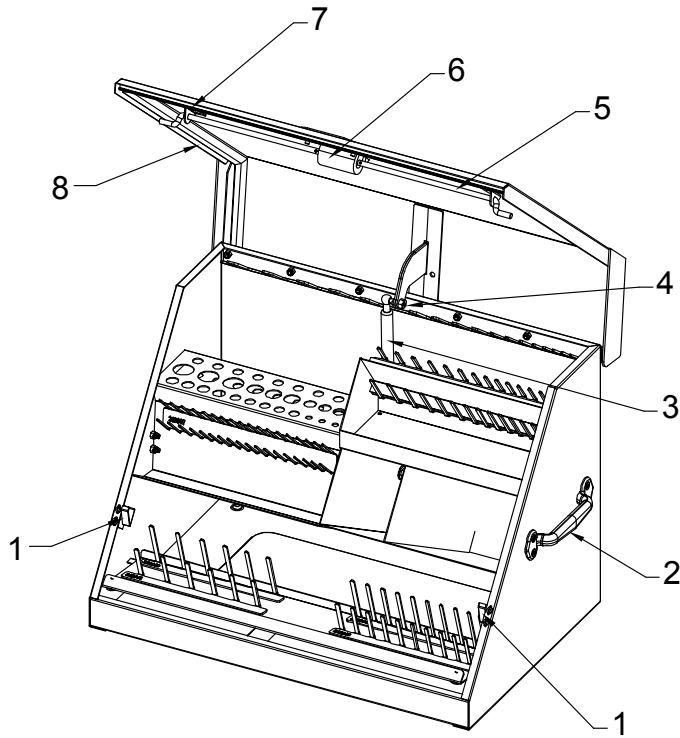

26" X 17" PORTABLE ALUMINUM TOOLBOX

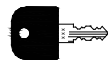

The keys are taped to the top storage area of the chest.

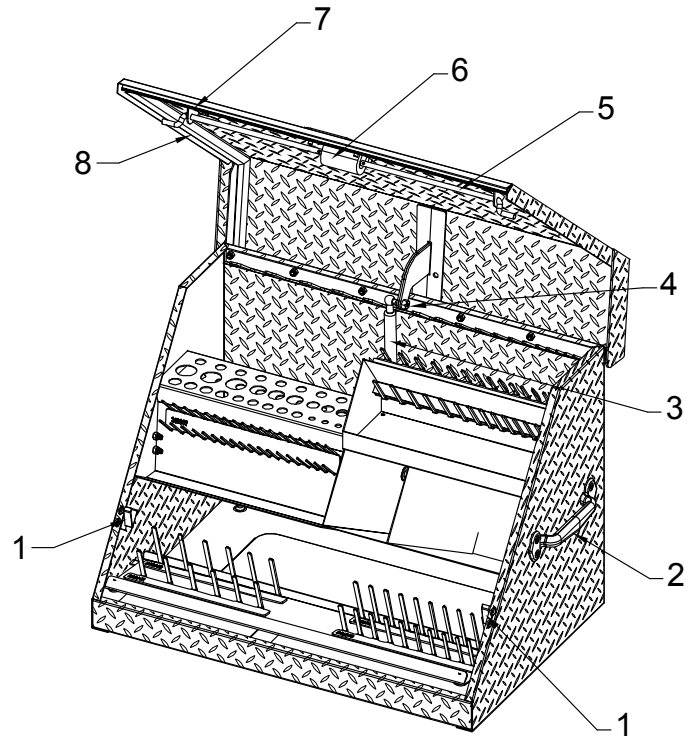

	PART #	DESCRIPTION	QTY
1	304015-304016	Striker Kit Set	1
2	306039	Side Handle	2
3	303034	Gas Spring	1
4	323000	Lock Nut	2
5	304018	Rod	2
6	304042	Latch (801-810)	1
7	314029	670 mm Weatherstripping	1
8	314074	650 mm Weatherstripping	2

	PART #	DESCRIPTION	QTY
1	304015-304016	Striker Kit Set	1
2	306039	Side Handle	2
3	303035	Gas Spring	1
4	323000	Lock Nut	2
5	304018	Rod	2
6	304042	Latch (801-810)	1
7	314093	674 mm Weatherstripping	1
8	314094	658 mm Weatherstripping	2

To order replacement parts, go to www.qualitycraft.com and click on Customer Support. Have the part number and quantity ready. Replacement keys may be ordered using the code that appears on the face of the lock. Not all parts are available under warranty. Those parts not available may be purchased.

30" X 15" PORTABLE STEEL TOOLBOX



The keys are taped to the top storage area of the chest.

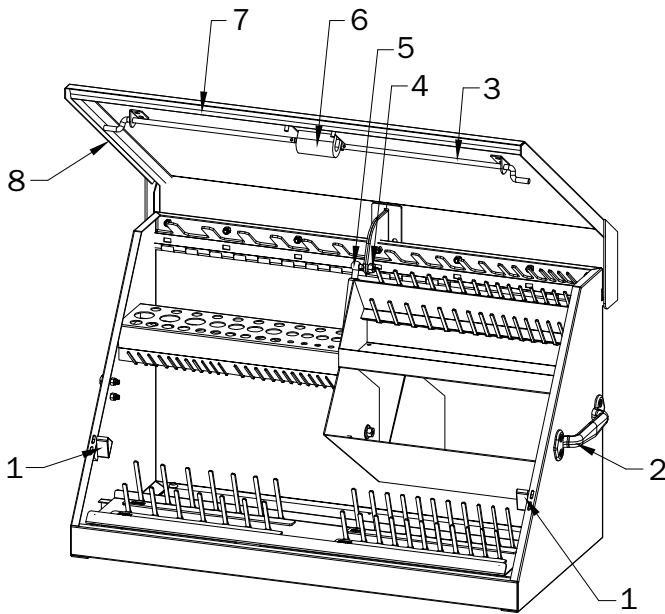

30" X 15" PORTABLE ALUMINUM TOOLBOX

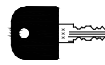

The keys are taped to the top storage area of the chest.

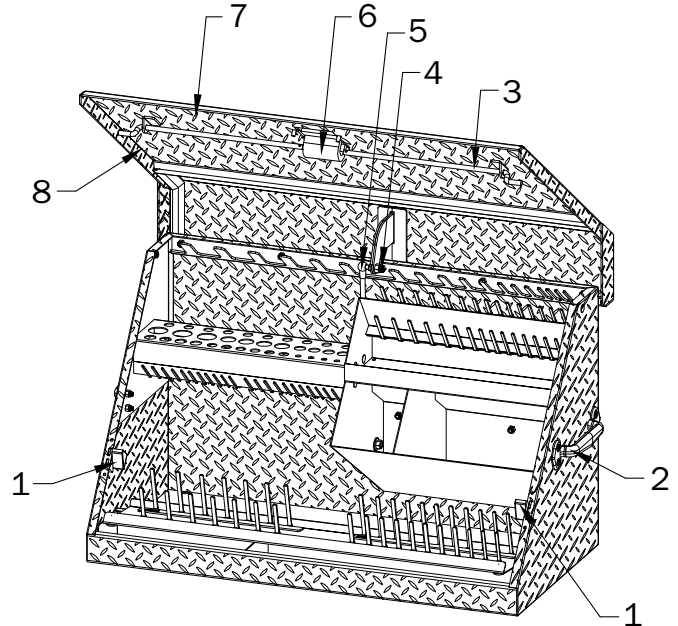

	PART #	DESCRIPTION	QTY
1	304015-304016	Striker Kit Set	1
2	306039	Side Handle	2
3	304014	Rod	2
4	323000	Lock Nut	2
5	303034	Gas Spring	1
6	304042	Latch (801-810)	1
7	314013	770 mm Weatherstripping	1
8	314016	592 mm Weatherstripping	2

	PART #	DESCRIPTION	QTY
1	304015-304016	Striker Kit Set	1
2	306039	Side Handle	2
3	304014	Rod	2
4	323000	Lock Nut	2
5	303035	Gas Spring	1
6	304042	Latch (801-810)	1
7	314084	774 mm Weatherstripping	1
8	314014	600 mm Weatherstripping	2

To order replacement parts, go to www.qualitycraft.com and click on Customer Support. Have the part number and quantity ready. Replacement keys may be ordered using the code that appears on the face of the lock. Not all parts are available under warranty. Those parts not available may be purchased.

30" X 19" PORTABLE STEEL TOOLBOX



The keys are taped to the top storage area of the chest.

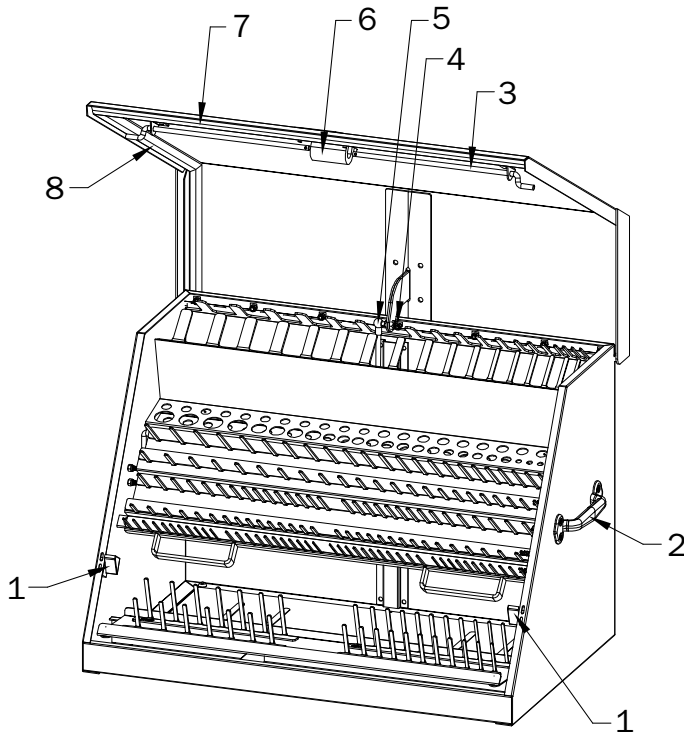

36" X 17" PORTABLE STEEL TOOLBOX

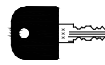

The keys are taped to the top storage area of the chest.

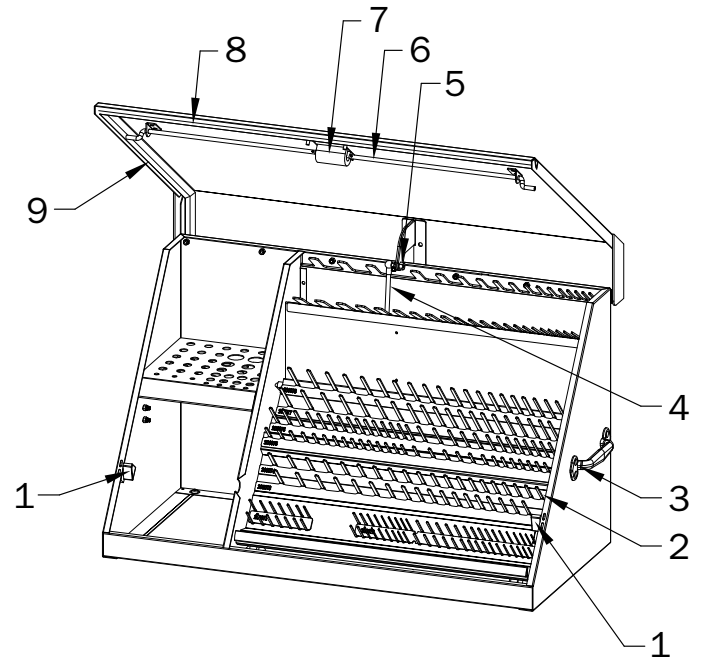

	PART #	DESCRIPTION	QTY
1	304015-304016	Striker Kit Set	1
2	306039	Side Handle	2
3	304014	Rod	2
4	323000	Lock Nut	2
5	303033	Gas Spring	1
6	304042	Latch (801-810)	1
7	314019	585 mm Weatherstripping	1
8	314020	492 mm Weatherstripping	2

	PART #	DESCRIPTION	QTY
1	304015-304016	Striker Kit Set	1
2	303036	Gas Spring	2
3	306039	Side Handle	2
4	303033	Gas Spring	1
5	323000	Lock Nut	6
6	304019	Rod	2
7	304042	Latch (801-810)	1
8	314041	930 mm Weatherstripping	1
9	314039	697 mm Weatherstripping	2

MAINTENANCE

Periodically clean the unit surfaces with mild detergent and water.

Auto wax can be used on painted (not aluminum) toolboxes to preserve the unit's luster finish and protect against scratches. Apply the wax as you would to a car.

Grease and oil can be removed with most standard cleaning fluids. For safety, use a nonflammable cleaning fluid.

SAFETY

CAUTION: The maximum product weight, including contents, is 500 lbs (226.8 kg).

WARNING: DO NOT attempt to lift the unit by its side handles using chains, ropes or other lifting devices. The side handle could fail, which may cause personal injury or damage to the product.

WARNING: DO NOT stand on the toolbox.

WARNING: DO NOT alter this toolbox in any manner. For example, do not weld external lockbars or attach electrical equipment. This may cause product damage or personal injury.

CAUTION: Keep the product on level surfaces. The product could become unstable and tip if stored on an uneven surface, which may cause personal injury or product damage.

WARNING: Lock the lid before moving this product. The lid could come open and make the product unstable, which may cause personal injury or product damage.

WARNING: Be careful with sharp edges.

CAUTION: Always wear ANSI approved safety goggles when working with tools and equipment.

FIVE YEAR LIMITED WARRANTY

The product is warranted to be free from defects in materials and workmanship for a period of five (5) years from the date of original purchase. This warranty does not apply to products that have been misused, abused, damaged by accident or otherwise, subjected to abnormal use, or modified. If this product is defective, please go to www.qualitycraft.com and click on Customer Support. If the product is defective, in our opinion, we will replace the defective part at no cost to you. Please do not ship your product back to the store or to us, unless we send you written instructions for return. In the event it becomes necessary for your product to be returned, we will notify you how to proceed. A copy of your original purchase receipt **MUST** accompany the returned product.

Manufactured by:

Quality Craft
Surrey, BC, Canada V3S 5N4
service@qualitycraft.ca
1-800-459-4409
(Monday–Friday, 8 am to 5 pm, CST)

Made in China

FORM#: MZPTB-06/16