



OPERATING MANUAL (ANSI/CSA)

# ROUGH TERRAIN SCISSORS

MODELS **SJ6826 RT** **SJ6832 RT**

159153AC-A March 2015

**SKYJACK**

**This manual is based on Serial Number(s):**

SJ 68XXRT 37 004 671 - 37 006 145

Please refer to the website ([www.skyjack.com](http://www.skyjack.com)) for older Serial Numbers.

**Skyjack Service Center**

3451 Swenson Ave. St. Charles,  
Illinois, 60174 USA  
Phone: 630-262-0005  
Toll Free: 1-800-275-9522  
Fax: 630-262-0006  
Email: [service@skyjack.com](mailto:service@skyjack.com)

**Parts (North America)**

Toll Free: 1-800-965-4626  
Toll Free Fax: 1-888-782-4825  
E-mail: [parts@skyjack.com](mailto:parts@skyjack.com)

**Skyjack Australia Pty Ltd.**

4 Coates Place  
Wetherill Park  
New South Wales 2164  
Australia  
Tel: +61 (0) 28786 3200  
Fax: +61(0) 28786 3222

**Parts & Service (Europe)**

Unit 1 Maes Y Clawdd  
Maesbury Road Industrial Estate  
Oswestry, Shropshire SY10 8NN UK  
Phone: +44-1691-676-235  
Fax: +44-1691-676-238  
E-mail: [info@skyjackeurope.co.uk](mailto:info@skyjackeurope.co.uk)

**Skyjack Brasil**

Alameda Júpiter, 710  
Loteamento American Park Empresarial  
Indaiatuba, SP, Brasil 13347-653  
Tel: +55 19 3936 0132

---

The Safety Alert Symbol identifies important safety messages on aerial platform, safety signs in manuals or elsewhere. When you see this symbol, be alert to the possibility of personal injury or death. Follow the instructions in the safety message.



**This Safety Alert Symbol means attention!**

**Become alert! Your safety is involved.**



**DANGER**

**DANGER indicates an imminently hazardous situation which, if not avoided, will result in death or serious injury.**



**WARNING**

**WARNING indicates a potentially hazardous situation which, if not avoided, could result in death or serious injury.**



**CAUTION**

**CAUTION indicates a potentially hazardous situation which, if not avoided, may result in minor or moderate injury. It may also be used to alert against unsafe practices.**

**IMPORTANT**

**IMPORTANT indicates a procedure essential for safe operation and which, if not followed, may result in a malfunction or damage to the aerial platform.**

---

## Table of Contents

<b>Section 1 - About Your Aerial Platform .....</b>	<b>5</b>
Read and Heed .....	5
Safety Rules.....	6
<b>Section 2 - Familiarization .....</b>	<b>13</b>
2.1 Familiarization of SJ68RT Series.....	13
2.2 Component Identification .....	14
2.3 Visual & Daily Maintenance Inspections .....	18
2.4 Function Tests.....	27
2.5 Winching and Towing Procedure .....	36
2.6 Emergency Lowering Procedure .....	37
<b>Section 3 - Operation .....</b>	<b>39</b>
3.1 General .....	39
3.2 Major Components.....	40
3.3 Major Assemblies .....	41
3.4 Serial Number Nameplate .....	41
3.5 Component Identification .....	42
3.6 Component Identification (Optional Equipment/Attachments) .....	44
3.7 Operator's Responsibility .....	46
3.8 Start Operation .....	47
3.9 Refueling Procedure.....	54
3.10 Guardrail Folding Procedure.....	56
3.11 Loading/Unloading .....	58
3.12 Moving the Aerial Platform Through a Doorway .....	60
3.13 Maintenance Support Procedure .....	62
<b>Section 4 - Tables.....</b>	<b>63</b>
Table 4.1 Standard and Optional Features .....	63
Table 4.2 Specifications and Features .....	64
Table 4.3 Owner's Annual Inspection Record.....	65
Table 4.4 Maximum Platform Capacities (Evenly Distributed).....	66
Table 4.5 Floor Loading Pressure .....	67
Table 4.6 Maintenance and Inspection Schedule.....	69
Table 4.7 Operator's Checklist.....	70
<b>Section 5 - Labels.....</b>	<b>71</b>

SKYJACK is continuously improving and expanding product features on its equipment, therefore, specifications and dimensions are subject to change without notice.

### Aerial Platform Definition

A mobile device that has an adjustable position platform supported from ground level by a structure.

### Purpose of Equipment

The SKYJACK Rough Terrain Compact Series aerial platform is designed to transport and raise personnel, tools and materials to overhead work areas.

### Use of Equipment

The aerial platform is a highly maneuverable, mobile work station. Work platform elevation and elevated driving must only be done on a firm, level surface. It can be driven over uneven terrain only when the platform is fully lowered.

### Manual

The operating manual is considered a fundamental part of the aerial platform. It is a very important way to communicate necessary safety information to users and operators. A complete and legible copy of this manual must be kept in the provided weather-resistant storage compartment on the aerial platform at all times.

### Operator

The operator must read and completely understand both this operating manual and the safety panel label located on the platform and all other warnings in this manual and on the aerial platform. Compare the labels on the aerial platform with the labels found within this manual. If any labels are damaged or missing, replace them immediately.

### Service Policy and Warranty

SKYJACK warrants each new SJRT Compact Series work platform to be free of defective parts and workmanship for the first 24 months. Any defective part will be replaced or repaired by your local SKYJACK dealer at no charge for parts or labor. Contact the SKYJACK Service Department for warranty statement extensions or exclusions.

### Optional Accessories

The SKYJACK aerial platform is designed to accept a variety of optional accessories. These are listed under “Standard and Optional Features” in [Table 4.1](#). Operating instructions for these options (if equipped) are located in [Section 3](#) of this manual.

For non-standard components or systems, contact the SKYJACK Service Department at

☎ : 800 275-9522

☎ : 630 262-0006

Include the model and serial number for each applicable aerial platform.

### Scope of this Manual

- a. This manual applies to the ANSI/SIA, CSA version of the SJRT Compact Series aerial platform models listed on [Table 4.1](#).
  - **Equipment identified** with “ANSI” meets the ANSI SIA-A92.6-2006 standard.
  - **Equipment identified** with “CSA” meets the CSA B354.2-01 standard.
- b. **CSA (Canada)**

Operators are required to conform to national, territorial/provincial and local health and safety regulations applicable to the operation of this aerial platform.
- c. **ANSI/SIA (United States)**

Operators are required by the current ANSI/SIA A92.6 standards to read and understand their responsibilities in the manual of responsibilities before they use or operate this aerial platform.

**WARNING**

**Failure to comply with your required responsibilities in the use and operation of the aerial platform could result in death or serious injury!**

**Operator Safety Reminders**

A study conducted by St. Paul Travelers showed that most accidents are caused by the failure of the operator to follow simple and fundamental safety rules and precautions.

You, as a careful operator, are the best insurance against an accident. Therefore, proper usage of this aerial platform is mandatory. The following pages of this manual should be read and understood completely before operating the aerial platform.

Common sense dictates the use of protective clothing when working on or near machinery. Use appropriate safety devices to protect your eyes, ears, hands, feet and body.

Any modifications from the original design are strictly forbidden without written permission from SKYJACK.

**Electrocution Hazard**

This aerial platform is not electrically insulated. Maintain a Minimum Safe Approach Distance (MSAD) from energized power lines and parts as listed below. The operator must allow for the platform to sway, rock or sag. This aerial platform does not provide protection from contact with or proximity to an electrically charged conductor.

Per ANSI A92.6-2006 8.10(7)

“The operator shall perform only that work for which he or she is qualified, in compliance with all applicable safety related work practices intended to prevent electric shock covered by the Code of Federal Regulations (CFR) 1910.333. The operator’s level of competence shall be established only by persons qualified to do so. Operators shall maintain the appropriate minimum approach distance (MAD) from energized power lines and parts covered by CFR 1910.333 (c).”

Unqualified persons must maintain a minimum approach distance of 10 feet from any energized power line up to 50 kV. Energized power lines over 50 kV require a greater minimum approach distance to be maintained. Refer to CFR 1910.333.

As per CSA B354.2-01

“The operator shall maintain the minimum safe approach distance (MSAD) from energized conductors at all times in accordance with the authority having jurisdiction.”

As per AS 2550.1-2002

Elevating Work Platforms must remain 6.4 m from electrical distribution lines up to 133 kV and 8 m from transmission lines greater than 133 kV. State regulations may take precedence over these approach distances.

**DO NOT USE THE AERIAL PLATFORM AS A GROUND FOR WELDING.  
DO NOT OPERATE THE AERIAL PLATFORM DURING LIGHTNING OR STORMS.  
DO NOT OPERATE THE AERIAL PLATFORM NEAR POWER LINES. MAINTAIN A MINIMUM SAFE APPROACH DISTANCE (MSAD) FROM ENERGIZED POWER LINES.**

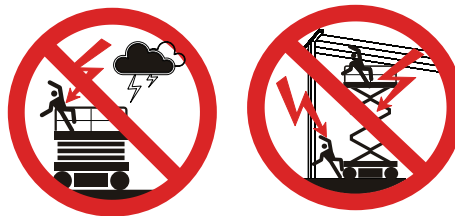

 <b>DANGER</b> Avoid Power Lines	
<b>Minimum Safe Approach Distance</b>	
<b>ANSI/SIA A92.6-2006 &amp; CSA B354.2-01 Requirements</b>	
Voltage Range (Phase to Phase)	Minimum Safe Approach Distance (Feet)
0 to 300V	Avoid Contact
Over 300V to 50KV	10
Over 50KV to 200KV	15
Over 200KV to 350KV	20
Over 350KV to 500KV	25
Over 500KV to 750KV	35
Over 750KV to 1000KV	45
<b>FAILURE TO AVOID THIS HAZARD WILL RESULT IN DEATH OR SERIOUS INJURY!</b>	

60023AD-ANSI

**Safety Precautions**

Know and understand the safety precautions before going on to next section.



**WARNING**

Failure to heed the following safety precautions could result in tip over, falling, crushing, or other hazards leading to death or serious injury.

- **KNOW** all national, state/provincial and local rules which apply to your aerial platform and jobsite.
- **TURN** emergency main power disconnect switch “O” off when leaving the aerial platform unattended. Remove the key to prevent unauthorized use of the aerial platform.
- **WEAR** all the protective clothing and personal safety devices issued to you or called for by job conditions.

- **DO NOT** wear loose clothing, dangling neckties, scarves, rings, wristwatches or other jewelry while operating this aerial platform.



- **AVOID** entanglement with ropes, cords or hoses.



- **AVOID** falling. Stay within the boundaries of the guardrails.



- **DO NOT** raise the MEWP or operate elevated in windy or gusty conditions that exceed the limits specified in Section 4, Table 4.4.



- **DO NOT** increase the lateral surface area of the platform. Increasing the area exposed to the wind will decrease aerial platform stability. Avoid tenting.



- **DO NOT** elevate the aerial platform if it is not on a firm, level surface.

- **DO NOT** drive elevated near depressions or holes of any type, loading docks, debris, drop-offs or surfaces that may affect the stability of the aerial platform.



- **IF OPERATION IN AREAS WITH HOLES OR DROP-OFFS IS ABSOLUTELY NECESSARY**, elevated driving shall not be allowed. Position the aerial platform horizontally only with the platform fully-lowered. After ensuring that all 4 wheels or outriggers (if equipped) have contact with a firm, level surface, the aerial platform can be elevated. After elevation, the drive function must not be activated.



- **DO NOT** elevate or drive elevated on a slope. Elevated driving must be done on a firm, level surface.



- **DO NOT** ascend or descend a grade when elevated. When fully lowered, ascending or descending, only grades up to rated maximum listed in Table 4.2 are permissible.





### Safety Precautions (Continued)

Know and understand the safety precautions before going on to next section.

- **DO NOT** operate on surfaces not capable of holding the weight of the aerial platform including the rated load, e.g. covers, drains, and trenches.



- **DO NOT** drive elevated on a soft or uneven surface.

- **DO NOT** operate an aerial platform that has ladders, scaffolding or other devices mounted on it to increase its size or work height. It is prohibited.



- **DO NOT** exert side forces on aerial platform while elevated.



- **DO NOT** use the aerial platform as a crane. It is prohibited.



- **DO NOT** sit, stand or climb on the guardrails. It is prohibited.



- **DO NOT** climb on scissor arm assembly. It is prohibited.



- **AVOID** overhead obstructions. Be aware of overhead obstructions or other possible hazards around aerial platform when lifting or driving.



- **DO NOT** raise the aerial platform while the aerial platform is on a truck, fork lift or other device or vehicle.



- **AVOID** crushing hazards. Be aware of crushing hazards when lifting or driving. Keep all body parts inside the aerial platform.



- **DO NOT** lower the platform unless the area below is clear of personnel and obstructions.



- **ENSURE** that there are no personnel or obstructions in the path of travel, including blind spots.



- **BE AWARE** of blind spots when operating the aerial platform.

- **ENSURE ALL** tires are in good condition and lug nuts are properly tightened.

- **DO NOT** use with improperly inflated/damaged tires or wheels. Refer to [Section 2: Wheel/Tire Assembly](#).



**Safety Precautions (Continued)**

Know and understand the safety precautions before going on to next section.

- **DO NOT** exceed the rated capacity of the aerial platform.



- **DO NOT** leave aerial platform unattended with key in key switch.



- **DO NOT** distribute load unevenly.



- **DO NOT** use under influence of alcohol or drugs.



- **DO NOT** alter or disable limit switches or other safety devices.

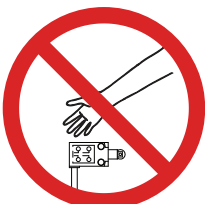

- **DO NOT** attempt to free a snagged platform with lower controls until personnel are removed from the platform.

- **DO NOT** position the aerial platform against another object to steady the platform.

- **DO NOT** use the aerial platform without guardrails, locking pins and the entry gate/chain/bar in place.

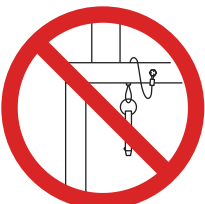

- **DO NOT** place materials on the guardrails or materials that exceed the confines of the guardrails unless approved by Skyjack.

- **STUNT** driving and horseplay are prohibited.

- **DO NOT** operate if aerial platform is not working properly or if any parts are damaged or worn.



### Safety Precautions (Continued)

Know and understand the safety precautions before going on to next section.

#### Fall Protection

As per the ANSI A92.6-2006 standard, “The guardrail system of the aerial platform provides fall protection. If occupant(s) of the platform are required to wear personal fall protection equipment (PFPE), occupants shall comply with instructions provided by the aerial platform manufacturer (remanufacturer) regarding anchorage(s).”

If additional fall protection is required, by an employer or the authority having jurisdiction, Skyjack recommends the use of a fall restraint system to keep an occupant within the confines of the platform, and thus not expose the occupant to any fall hazard requiring a fall arrest.

All personal fall protection equipment must comply with applicable governmental regulations and must be inspected and used in accordance with the manufacturer’s recommendations.

All personal fall protection equipment must be attached only to approved anchorage points within the platform of the aerial platform.



#### **WARNING**

**Entering and exiting the aerial platform should only be done using the three points of contact.**

- **Use only equipped access openings.**
- **Enter and exit only when the aerial platform is in the fully retracted position.**
- Do use three points of contact to enter and exit the platform. Enter and exit the platform from the ground only. Face the aerial platform when entering or exiting the platform.
- Three points of contact means that two hands and one foot or one hand and two feet are in contact with the aerial platform or the ground at all times during entering and exiting.



#### **WARNING**

**An operator should not use any aerial platform that:**

- **does not appear to be working properly.**
- **has been damaged or appears to have worn or missing parts.**
- **has alterations or modifications not approved by the manufacturer.**
- **has safety devices which have been altered or disabled.**
- **has been tagged or blocked out for non-use or repair.**

**Failure to avoid these hazards could result in death or serious injury.**

#### Jobsite Inspection

- Do not use in hazardous locations.
- Perform a thorough jobsite inspection prior to operating the aerial platform, to identify potential hazards in your work area.
- Be aware of moving equipment in the area. Take appropriate actions to avoid collision.



### 2.1 Familiarization of SJ68RT Series



#### WARNING

Aerial Platform Familiarization should be given only to individuals who are **QUALIFIED** and **TRAINED** to operate an aerial platform.

Do not operate this aerial platform without proper authorization and training. Failure to avoid this hazard could result in death or serious injury.

It is the responsibility of the operator to read, completely understand and follow all instructions and warnings contained in this operating manual and on the aerial platform.

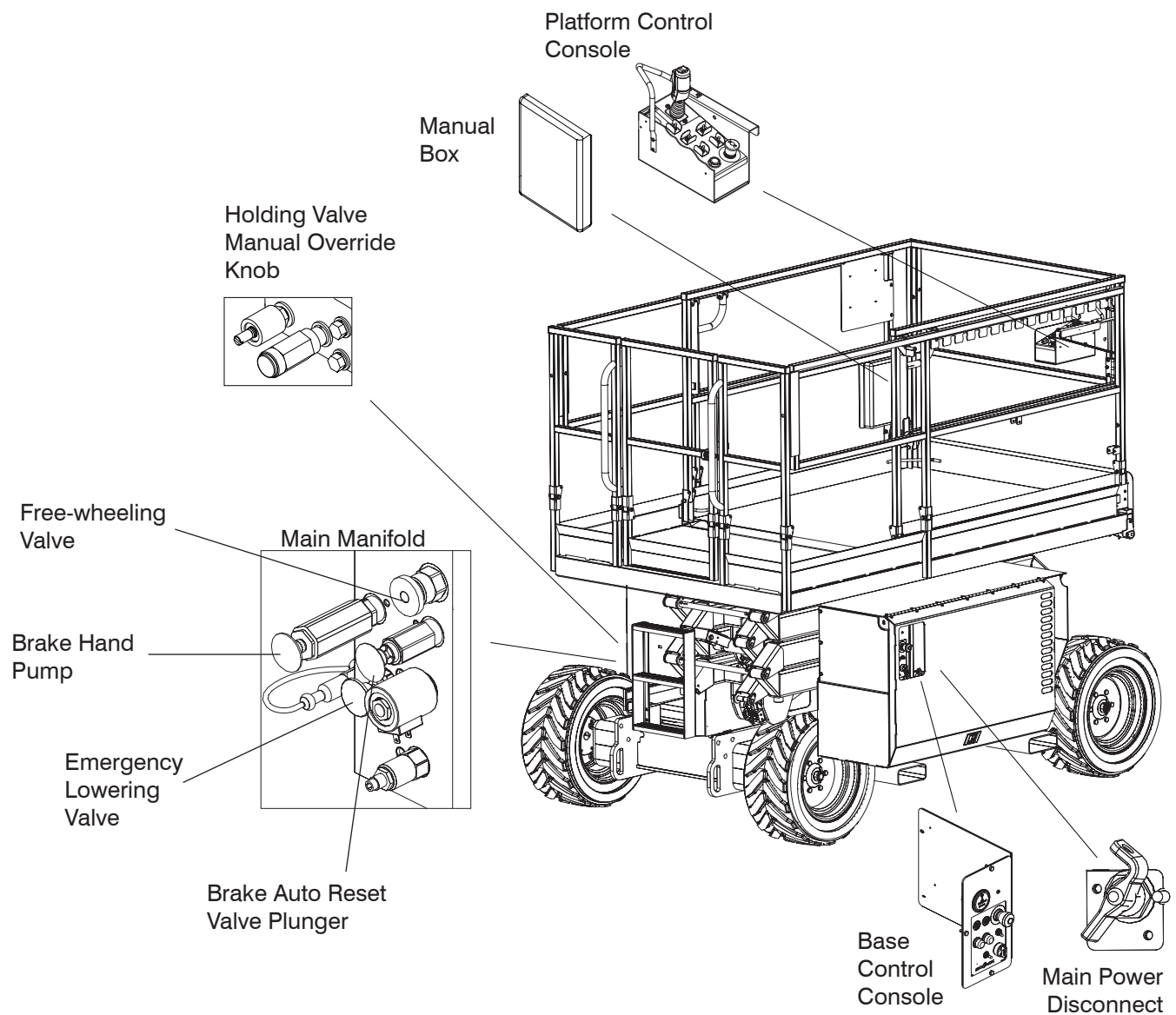

FAMILIARIZATION

## 2.2 Component Identification

The following descriptions are for identification, explanation and locating purposes only.

### 2.2-1 Emergency Main Power Disconnect Switch

This switch is located at the left side of the engine compartment.

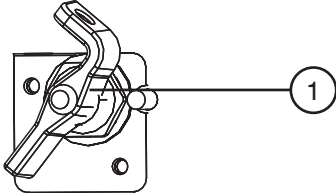

Figure 2-1. Emergency Main Power Disconnect Switch

1. **Emergency Main Power Disconnect Switch** - This switch, when in “○” off position, disconnects power to all circuits. Switch must be in “|” on position to operate any circuit. Turn switch “○” off when transporting aerial platform.

### 2.2-2 Motion Alarm

The alarm produces an audible sound when any control function is selected. On aerial platforms with certain options, a flashing amber light will accompany this alarm.

### 2.2-3 Tilt Alarm

The aerial platform is equipped with a device which senses when the aerial platform is out of level in any direction. When activated, it disables drive and lift functions of the aerial platform and an alarm produces an audible sound accompanied by the amber light. If the alarm sounds, lower the platform completely, then reposition aerial platform so that it is level before raising the platform.

#### NOTE

If the tilt alarm sounds and the platform does not, or only partially raises, immediately lower the platform completely and ensure that the aerial platform is on a firm, level surface.

### 2.2-4 Brake System

The brake system is located on the main manifold in the hydraulic/fuel compartment. The brakes must be manually disengaged before pushing, winching or towing. Refer to [Section 2.5-2](#) for procedure on how to release the brakes manually. The system contains the following controls:

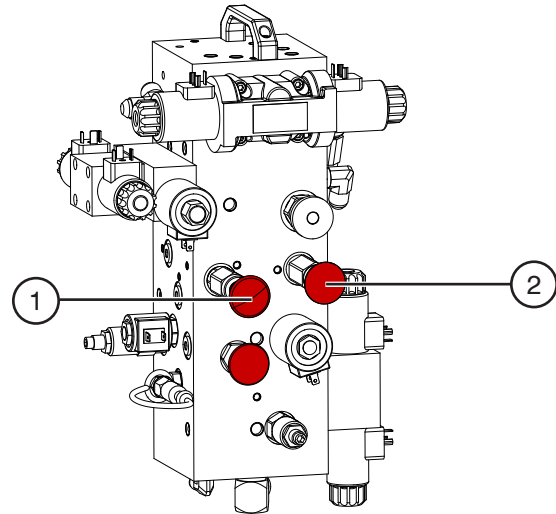

Figure 2-2. Brake System

1. Brake hand pump
2. Brake auto reset valve plunger

### 2.2-5 Emergency Lowering System

The emergency lowering system allows platform lowering in the event of an emergency or an electrical system failure. Refer to [Section 2.6](#) for the emergency lowering procedure. The system contains the following controls:

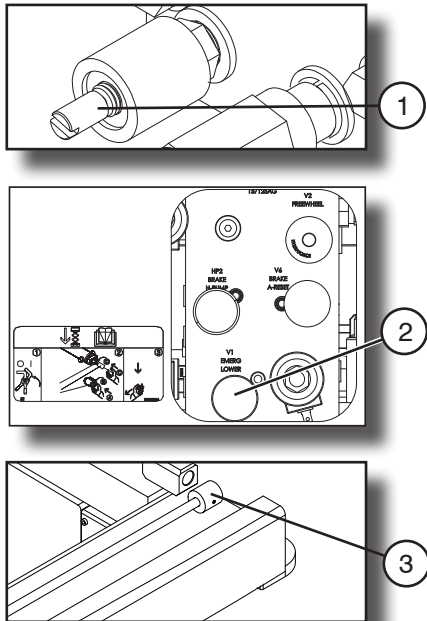

Figure 2-3. Emergency Lowering System

1. **Holding Valve Manual Override Knob** - Located on the holding valve at the bottom of each lift cylinder.
2. **Emergency Lowering Valve** - Located at the hydraulic/fuel compartment.
3. **Emergency Lowering Access Rod** - Located at the right side of the base.

### 2.2-6 Free-wheeling Valve

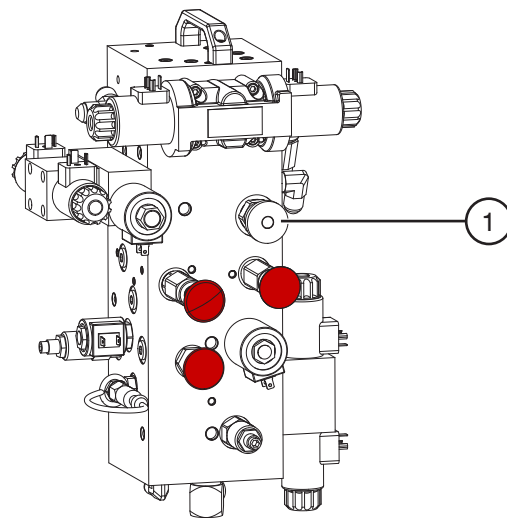

Figure 2-4. Free-wheeling Valve

1. **Free-wheeling Valve** - The free-wheeling valve is located on the main manifold in the hydraulic/fuel compartment. Refer to [Section 2.5-1](#) for procedure on how to release the free-wheeling valve.

### 2.2-7 Propane Cylinder

The propane cylinder is located on the base of the aerial platform. It has the following control:

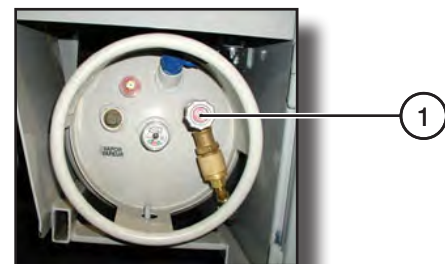

Figure 2-5. Propane Cylinder

1. **Cylinder Main Valve** - Turn this valve clockwise to shut off the fuel supply; counterclockwise to open it.

**2.2-8 Base Control Console**

The control console is located on the left side of the engine compartment. It contains the following controls:

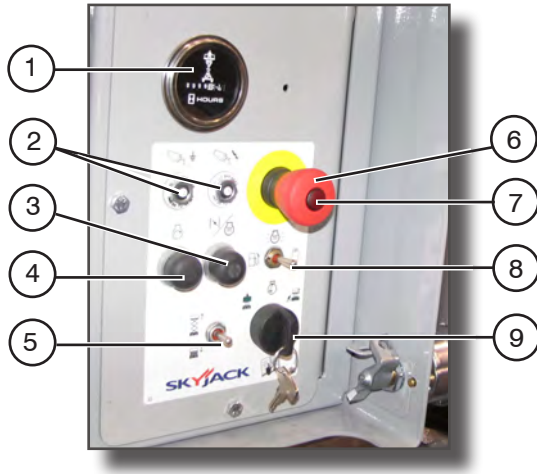

Figure 2-6. Base Control Console - Dual Fuel

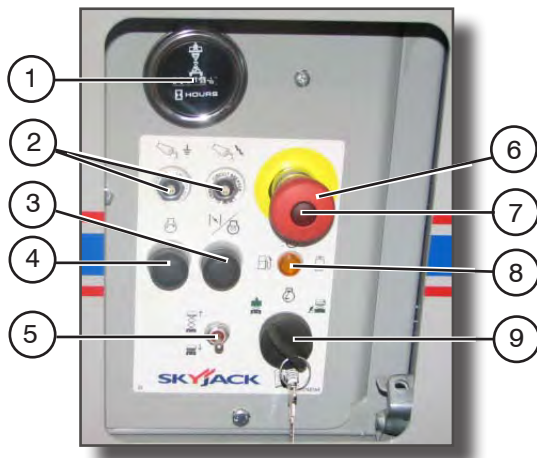











Figure 2-7. Base Control Console - Diesel

1. **Hourmeter** - This gauge records accumulated operating time of engine.
2. **Circuit Breakers** - In the event of a power overload or positive circuit grounding, the circuit breaker pops out. Push breaker back in to reset.
3. **Choke Pushbutton (Dual Fuel)** - This pushbutton switch aids in starting a cold dual-fuel engine.

**Glow Plug Pushbutton (Diesel)** - This pushbutton switch energizes the glow plugs to aid in starting a cold diesel engine.

4. **Engine Start Pushbutton** - This pushbutton “” energizes the engine starter motor.
  5. **Platform Raise/Lower Switch** - This switch controls “” raising or “” lowering of platform.
  6. **Emergency Stop Button** - This button “”, when depressed, disconnects power to control circuit and shuts engine off.
  7. **Power Indicator Light** - When the emergency stop button on the base control console and on the platform control console are both pulled out, this light glows.
  8. **Fuel Switch (Dual Fuel)** - Used to switch between “” liquid propane gas and “” gasoline.
- Glow Plug Indicator Light (Diesel)** - This red lamp “” illuminates until the glow plugs have completed their timed heating cycle. When the lamp goes out, the engine is ready to be started.
9. **Platform/Engine/Base Key Switch** - This three-way selector switch allows the operator to turn the “” engine in an idling mode or to activate either the “” base or “” platform controls.



### 2.2-9 Platform Control Console

This removable control console is mounted at the right front of the platform. It contains the following controls:

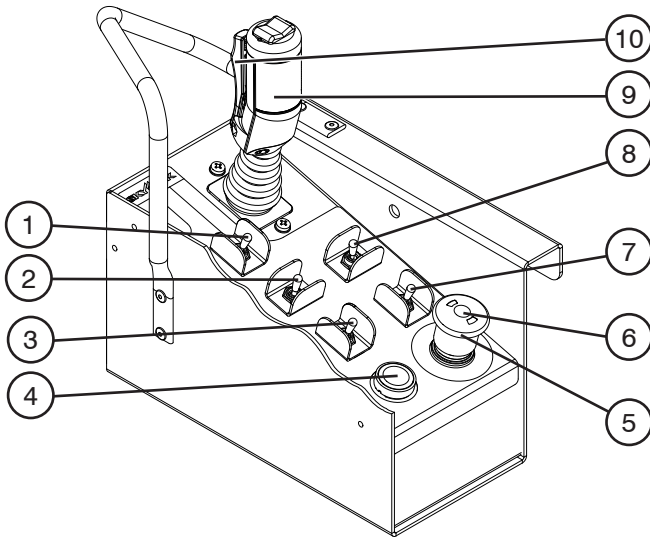













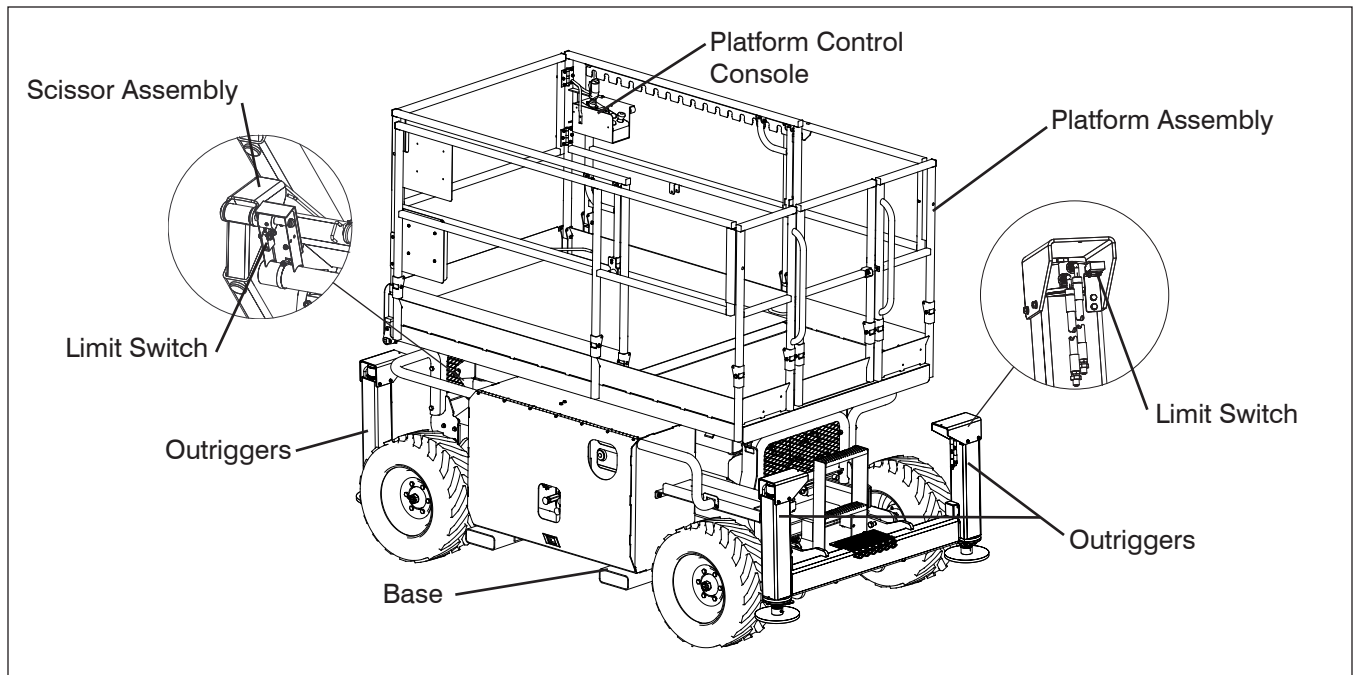

Figure 2-8. Platform Control Console

1. **Torque Switch** - This selector switch, when in “” low speed position, it allows drive functions to operate at low speed and maximum torque when climbing grades and on rough terrain. When in “” high speed position, it allows drive functions to operate at high speed with minimum torque.
  2. **Lift/Drive Switch** - Selecting “” lift position energizes the lift circuit. Selecting “” drive position energizes the drive circuit.
  3. **Engine Start Switch** - This “” switch energizes the engine starter motor.
- NOTE**
- The engine start switch is interlocked with the oil pressure switch. If engine stalls or does not start immediately, this button will not work for a few seconds while oil pressure bleeds off.
4. **Horn Pushbutton** - This “” pushbutton sounds an automotive-type horn.
  5. **Emergency Stop Button** - This button “”, when depressed, disconnects power to the control circuit.
  6. **Power Indicator Light** - This light glows when “” platform is selected from the platform/engine/base key switch on the base control console. It also glows when both emergency stop buttons on the platform control console and the base control console are pulled out.
  7. **Choke Switch (Dual Fuel)** - This switch sets the “” choke for starting a cold gasoline/propane engine.
  - Glow Plug Switch (Diesel)** - This switch energizes the “” glow plugs to aid in starting a cold diesel engine.
  8. **Low/High Throttle Switch** - This switch allows selection between “” low and “” high engine throttle speeds.
  9. **Lift/Drive/Steer Controller** - This one-hand lever controls lift/drive and steer motions. Internal springs return it to neutral when controller is released. The rocker switch on top of controller handle controls steering function.
  10. **Lift/Drive/Steer Enable Trigger Switch** - This momentary “” switch energizes the controller. It must be held depressed continuously while engaging either the lift/drive or steer functions.



### 2.3 Visual & Daily Maintenance Inspections

Begin the visual and daily maintenance inspections by checking each item in sequence for the conditions listed in this section.

**! WARNING**

To avoid injury, do not operate an aerial platform until all malfunctions have been corrected.

**! WARNING**

To avoid possible injury, ensure aerial platform power is off during your visual and daily maintenance inspections.

**! CAUTION**

Ensure aerial platform is on a firm, level surface.

**NOTE**

While doing visual and daily inspections in different areas, be aware to also inspect limit switches, electrical and hydraulic components.

#### 2.3-1 Labels

Refer to [Section 5 - Labels](#) in this manual and determine that all labels are in place and are legible.

#### 2.3-2 Electrical

Maintaining the electrical components is essential to good performance and service life of the aerial platform.

Inspect the following areas for chafed, corroded and loose wires:

- base to platform cables and wiring harness
- engine compartment electrical panel
- engine wiring harness
- hydraulic/electrical wiring harnesses

#### 2.3-3 Limit Switches

Ensure limit switches are properly secured with no signs of visible damage and movement is not obstructed.

#### 2.3-4 Hydraulic

Maintaining the hydraulic components is essential to good performance and service life of the aerial platform.

Perform a visual inspection around the following areas:

- hydraulic tank filter, fittings, hoses, emergency power unit (if equipped) and base surfaces
- engine compartment fittings, hoses, main pump, and filter
- all hydraulic cylinders
- all hydraulic manifolds
- the underside of the base
- ground area under the aerial platform
- outriggers (if equipped)

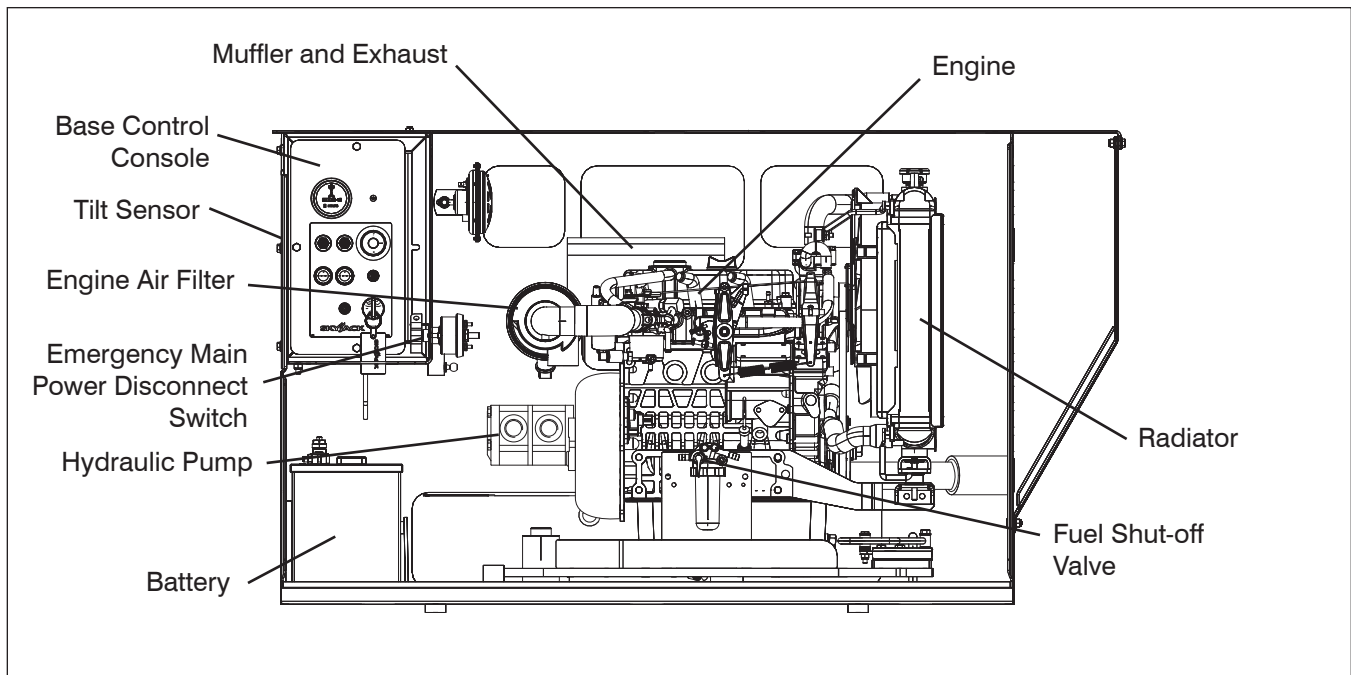

### 2.3-5 Engine Compartment

- Ensure compartment latch is secure and in proper working order.
- **Main Power Disconnect Switch**
  - Turn emergency main power disconnect switch to “○” off position.
  - Ensure all cables are secure and switch is in proper working condition.
- **Base Control Switches**
  - Ensure there are no signs of visible damage and all switches are in their neutral positions.
- **Tilt Sensor**
  - Ensure tilt sensor is properly secure and there is no visible damage.
- **Battery**

Proper battery condition is essential to good performance and operational safety. Improper fluid levels or damaged cables and connections can result in component damage and hazardous conditions.



#### **WARNING**

Explosion hazard. Keep flames and sparks away. Do not smoke near batteries.



#### **WARNING**

Battery acid is extremely corrosive - Wear proper eye and facial protection as well as appropriate protective clothing. If contact occurs, immediately flush with cold water and seek medical attention.

1. Check battery case for damage.
2. Clean battery terminals and cable ends thoroughly with a terminal cleaning tool or wire brush.
3. Ensure all battery connections are tight.
4. If applicable, check battery fluid level. If plates are not covered by at least 1/2” (13 mm) of solution, add distilled or demineralized water.
5. Replace battery if damaged or incapable of holding a lasting charge.



#### **WARNING**

Use original or manufacturer-approved parts and components for the aerial platform.

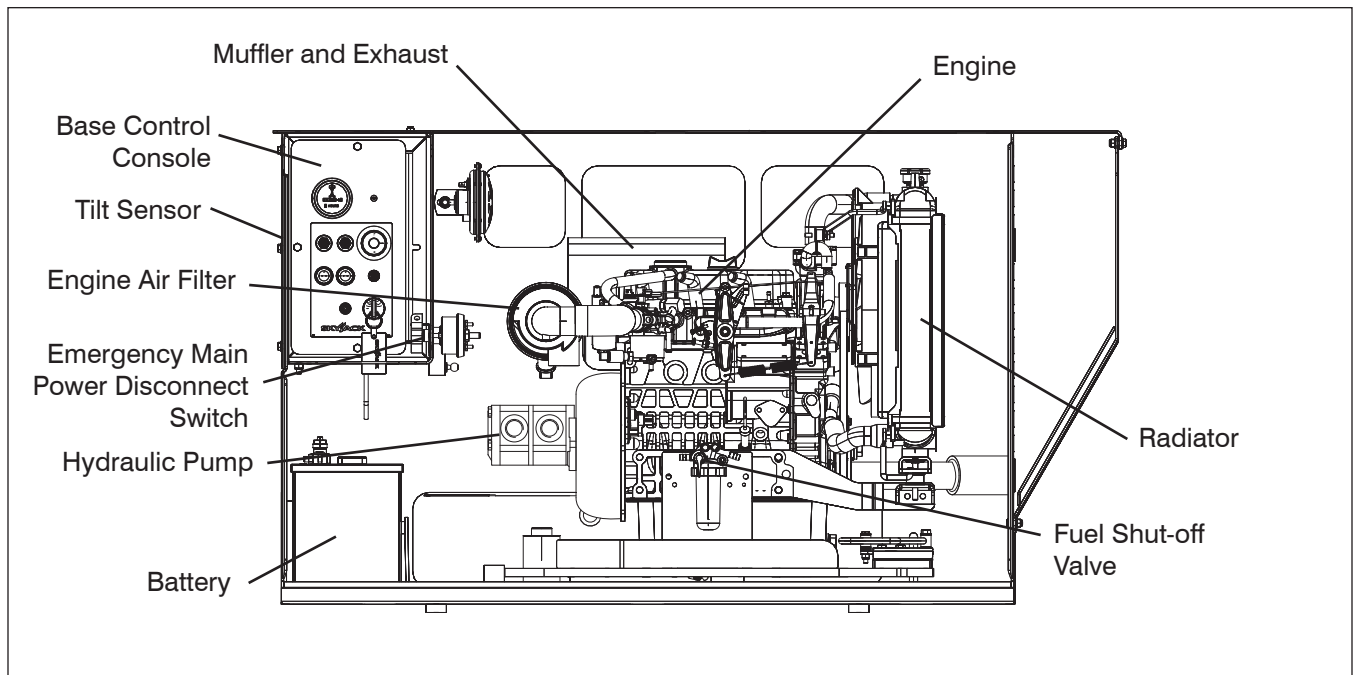

- **Hydraulic Pump**
  - Ensure there are no loose or missing parts and there is no visible damage.
  - Ensure all bolts are properly tightened.
  - Ensure all fittings and hoses are properly tightened and there is no evidence of hydraulic leakage.
- **Radiator**
  - Ensure radiator is secure.
  - Ensure there are no loose or missing parts and there is no visible damage.
  - Check coolant level and add as needed.
- **Muffler and Exhaust**
  - Ensure muffler and exhaust system are properly secured, with no evidence of damage.
- **Engine Pivot Tray**
  - Ensure there are no loose or missing parts and no visible damage to the engine pivot tray. Ensure that both tray-securing bolts are in place.
- **Engine Oil Level**
  - Maintaining the engine components is essential to good performance and service life of the aerial platform.



**WARNING**

**Beware of hot engine components.**

- **Check oil level on dipstick**
  - Oil level should be in the “safe” zone. Add oil as needed.
- **Fuel Shut-off Valve**
  - Ensure there are no loose or missing parts and there is no visible damage.
- **Engine Air Filter**
  - Ensure there are no loose or missing parts and there is no visible damage.

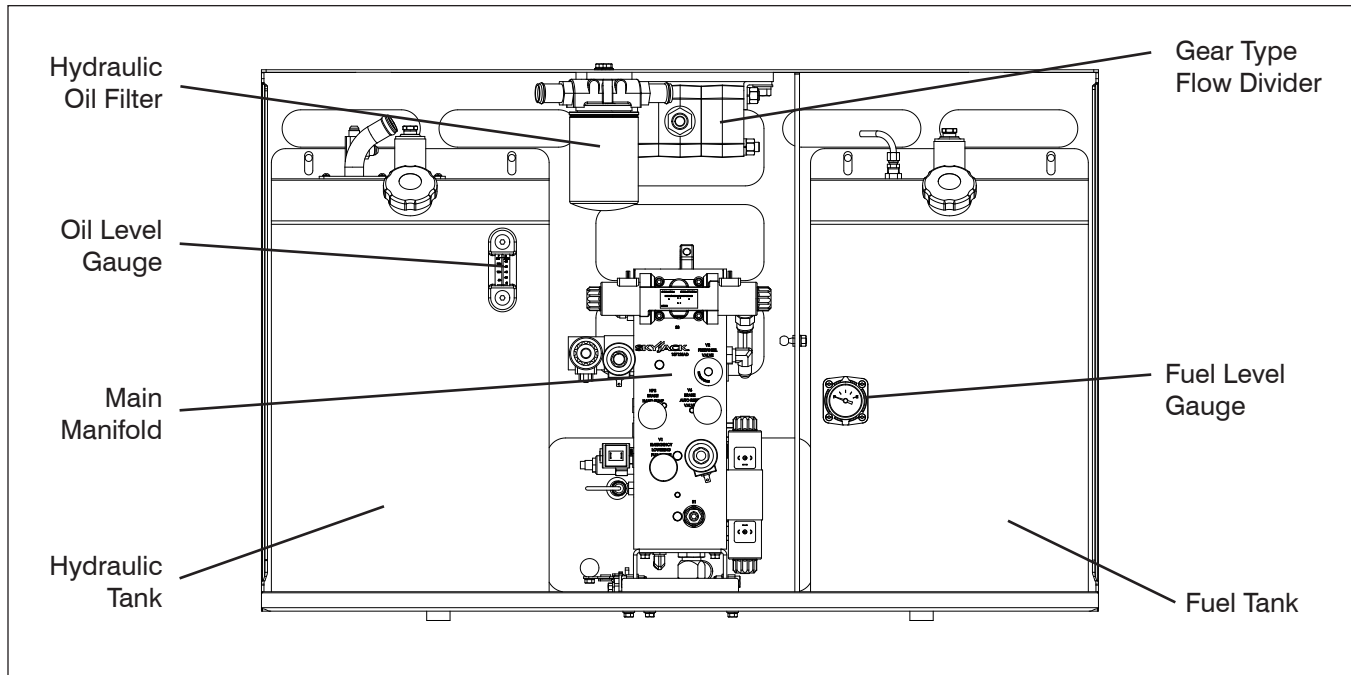

- **Fuel Leaks**

Failure to detect and correct fuel leaks will result in an unsafe condition. An explosion or fuel fire may cause death or serious injury.



**DANGER**

**Engine fuels are combustible. Inspect the aerial platform in an open, well-ventilated area away from heaters, sparks and flames. Always have an approved fire extinguisher within easy reach.**

Perform a visual inspection around the following areas:

- hoses and fittings
- fuel pump
- fuel filter

### 2.3-6 Hydraulic/Fuel Compartment

- Ensure compartment latch is secure and in proper working order.
- **Hydraulic Tank**
  - Ensure hydraulic filler cap is secure.
  - Ensure tank shows no visible damage and no evidence of hydraulic leakage.
- **Hydraulic Oil**
  - Ensure platform is fully lowered, and then visually inspect the sight gauge located on the side of the hydraulic oil tank.
  - The hydraulic oil level should be at or slightly above the top mark of the sight glass.
- **Hydraulic Return Filter**
  - Ensure filter element is secure.
  - Ensure there are no signs of leakage or visible damage.

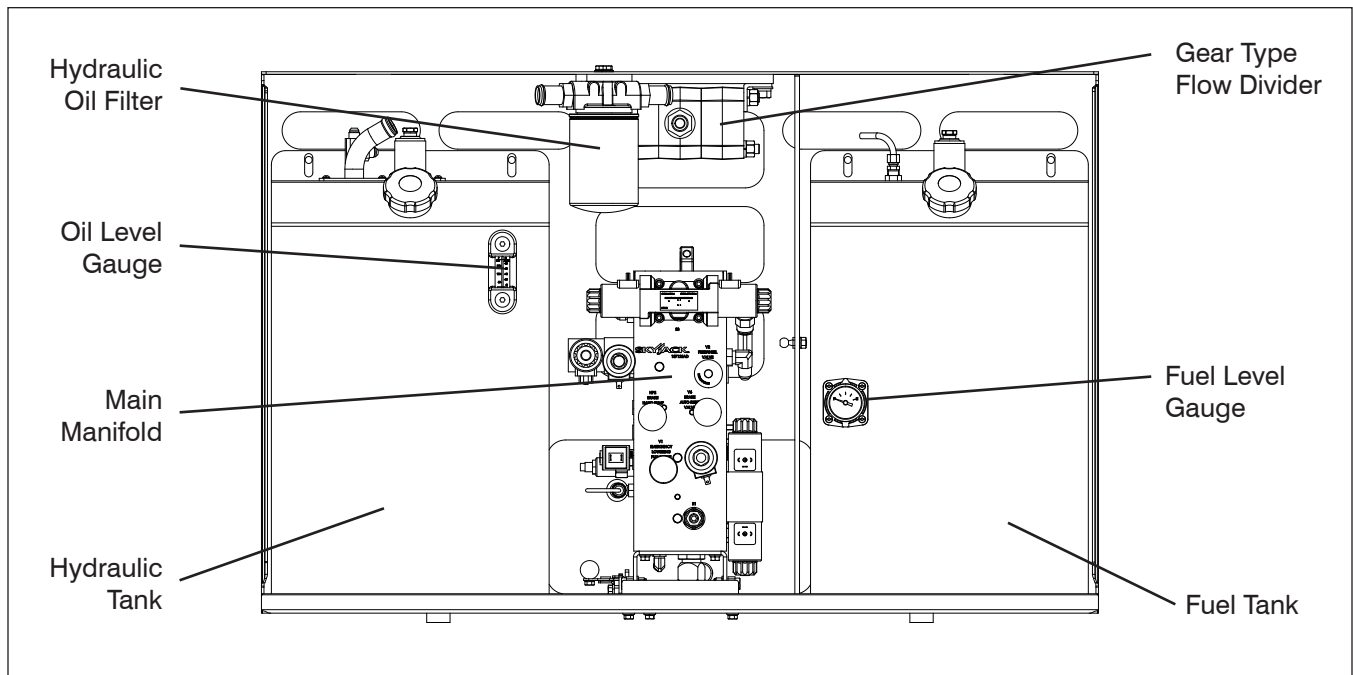

• **Fuel Tank**

**IMPORTANT**

**Before using your aerial platform ensure there is enough fuel for expected use.**

- Ensure fuel filler cap is secure.
- Ensure tank shows no visible damage and no evidence of fuel leakage.

• **Fuel Leaks**

Failure to detect and correct fuel leaks will result in an unsafe condition. An explosion or fuel fire may cause death or serious injury.



**DANGER**

**Engine fuels are combustible. Inspect the aerial platform in an open, well-ventilated area away from heaters, sparks and flames. Always have an approved fire extinguisher within easy reach.**

Perform a visual inspection around the following areas:

- fuel tank
- hoses and fittings

• **Main Manifold**

- Ensure all fittings and hoses are properly tightened and there is no evidence of hydraulic leakage.
- Ensure there are no loose wires or missing fasteners.

• **Gear Type Flow Divider**

- Ensure there are no loose or missing parts and there is no visible damage.

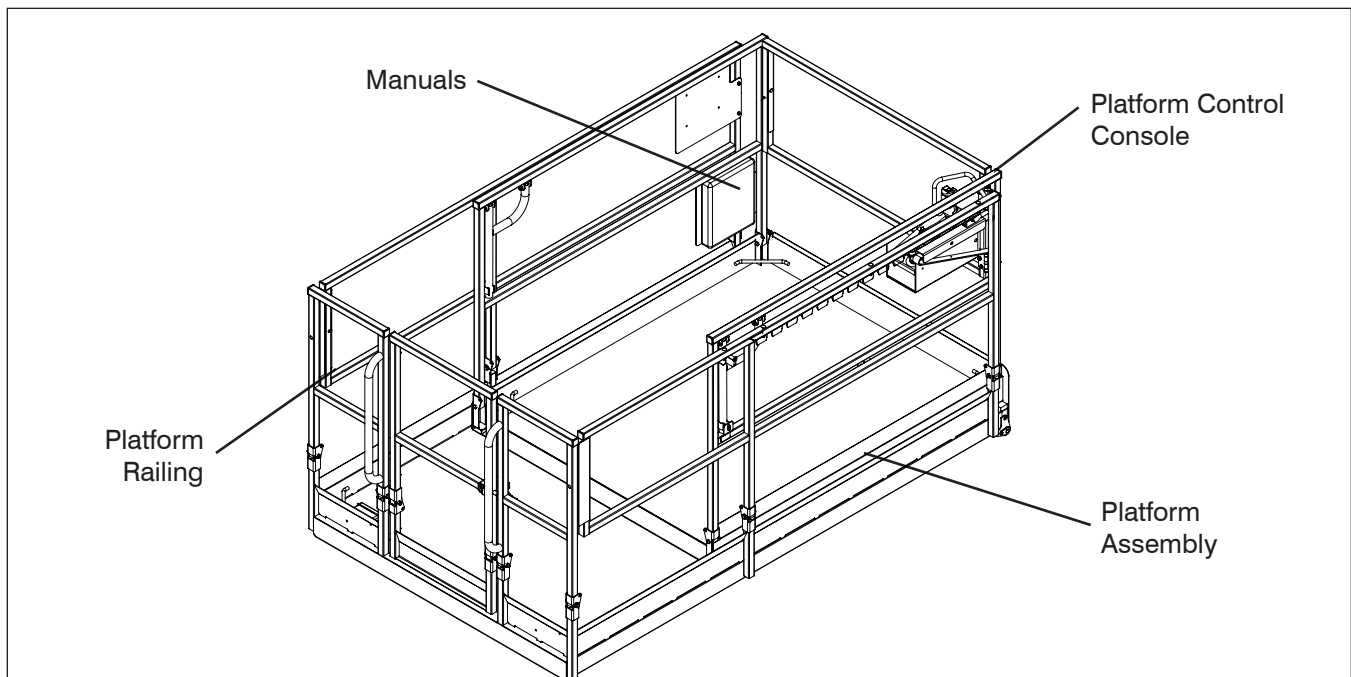

### 2.3-7 Platform Assembly



#### **WARNING**

**Ensure that you maintain three points of contact to mount/dismount platform.**

1. Use the ladder of aerial platform to platform.
2. Close the gate.
  - Ensure there are no loose or missing parts and there is no visible damage.
  - Ensure all fasteners are securely in place.
  - Ensure all railings are properly positioned and secured.
  - Ensure gate is in good working order.
- **Lanyard Attachment Anchors**
  - Ensure attachment rings are secure and no visible damage.
- **AC Outlet on Platform**
  - Ensure outlet has no visible damage and free from dirt or obstructions.

- **Manuals**

Ensure a copy of the operating manual and ANSI/CSA certificate are enclosed in manual storage box.

- Check to be sure manual storage box is present and in good condition.
- Ensure manuals are legible and in good condition.
- Always return manuals to the manual storage box after use.

- **Platform Control Console**

- Ensure all switches and controller are returned to neutral and are properly secured.
- Ensure there are no loose or missing parts and there is no visible damage.



#### **WARNING**

**Ensure that you maintain three points of contact to mount/dismount platform.**

3. Use the ladder to dismount from platform.

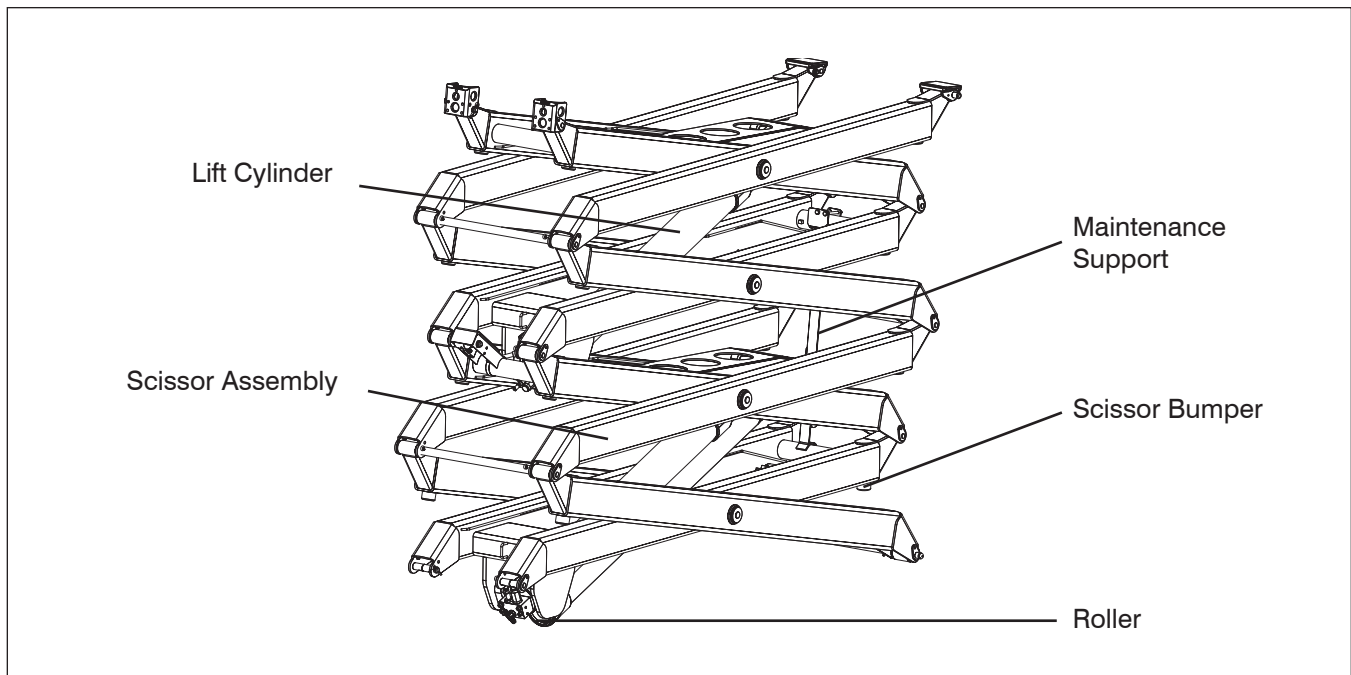

**2.3-8 Lifting Mechanism**

1. Raise the platform (refer to [Section 3.8-4](#)) until there is adequate clearance to swing down the maintenance support (refer to [Section 3.13](#)).

- **Maintenance Support**
  - Ensure maintenance support is properly secured and shows no visible damage.
- **Scissor Assembly**
  - Ensure scissor assembly shows no visible damage and no signs of deformation in weldments.
  - Ensure all pins are properly secured.
  - Ensure cables and wires are properly routed and shows no signs of wear and/or physical damage.
- **Scissor Bumpers**
  - Ensure bumpers are secure and shows no sign of visible damage.

- **Rollers**
    - Ensure rollers are secure and there is no visible damage.
    - Ensure rollers' path of travel are free from dirt and obstructions.
  - **Lift Cylinder(s)**
    - Ensure each lift cylinder is properly secured, there are no loose or missing parts and there is no evidence of damage.
    - Ensure all fittings and hoses are properly tightened and there is no evidence of hydraulic leakage.
2. Raise the platform until there is adequate clearance to swing up the maintenance support into storage bracket. Refer to [Section 3.13](#).
  3. Fully lower the platform.



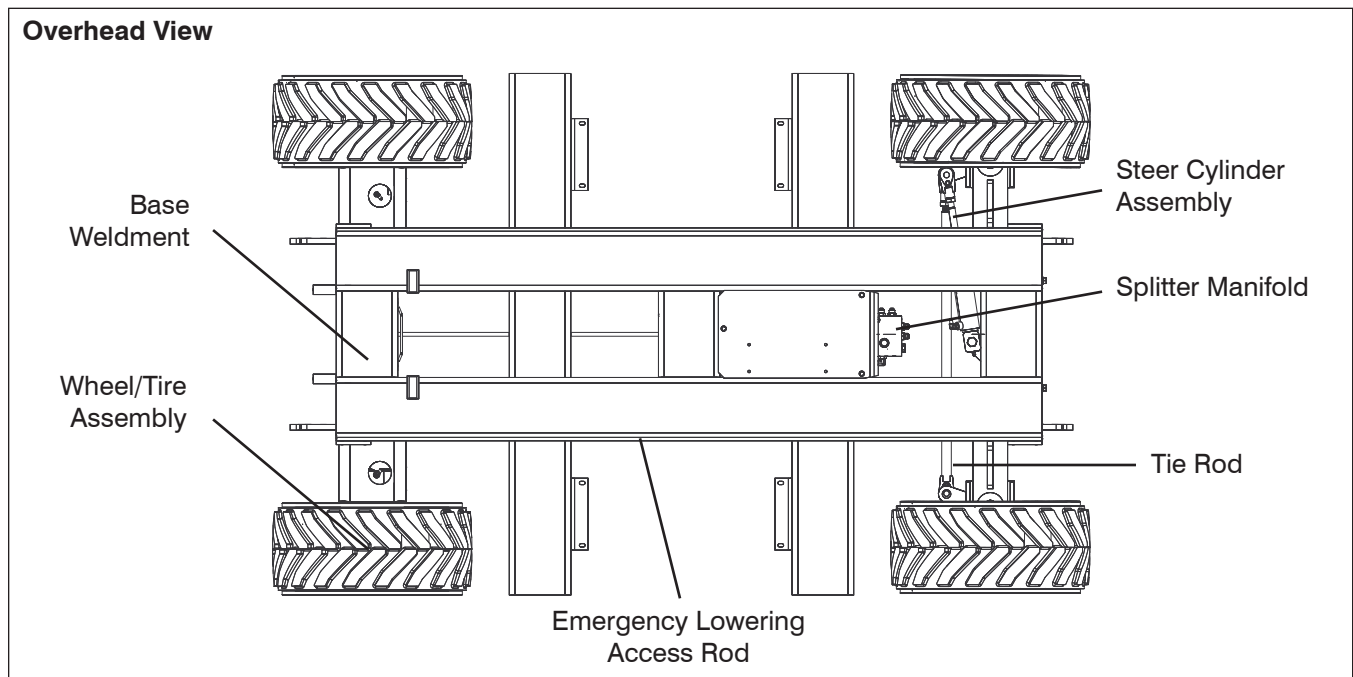

**2.3-9 Base**

• **Base Weldment**

- Ensure there are no visible cracks in welds or structure and there are no signs of deformation.

• **Wheel/Tire Assembly**

The aerial platform is either equipped with air tires or foam-filled tires. Tire and/or wheel failure could result in an aerial platform tipover. Component damage may also result if problems are not discovered and repaired in a timely fashion.

- Check all tire treads and sidewalls for cuts, cracks, punctures and unusual wear.
- Check each wheel for damage and cracked welds.
- Check each lug nut for proper torque to ensure none are loose.
- Check wheel motor assembly for loose or missing parts and signs of visible damage.
- Ensure wheels are aligned and true vertically and horizontally.



**WARNING**

**Air filled tires are not permitted on some models. Refer to Table 4.2.**



**WARNING**

**An over-inflated tire can explode and may cause death or serious injury.**



**WARNING**

**Intermixing tires of different types or using tires of types other than those originally supplied with this equipment can adversely affect stability. Therefore, replace tires only with the exact Skyjack-approved type. Failure to operate with matched approved tires in good condition may result in death or serious injury.**

FAMILIARIZATION

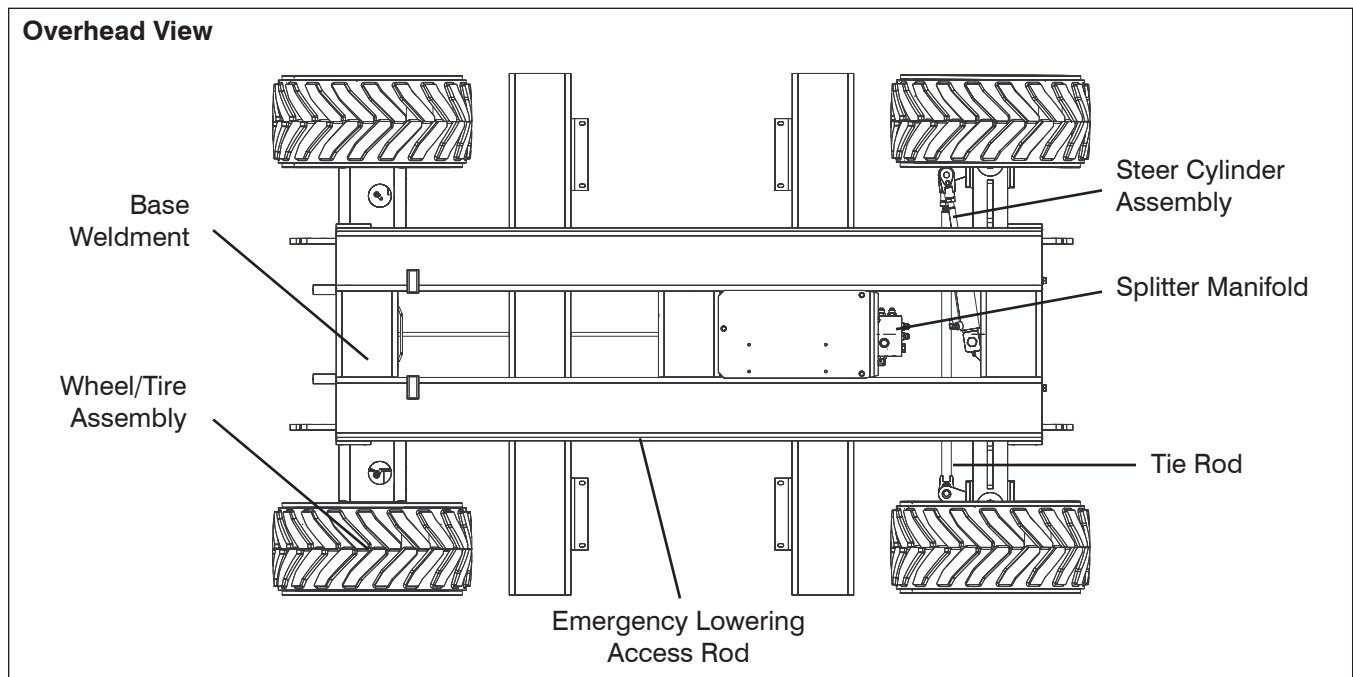

To safeguard maximum stability, achieve optimum aerial platform handling and minimize tire wear, it is essential to maintain proper pressure in all air-filled tires.

- Check each tire with an air pressure gauge and add air as needed.

Refer to [Table 4.2](#) for wheel/tire specifications.

- **Steer Cylinder Assembly**
  - Ensure steer cylinder assembly is properly secured, there are no loose or missing parts, all fittings and hoses are properly tightened and there is no evidence of hydraulic leakage.
- **Splitter Manifold**
  - Ensure all fittings and hoses are properly tightened and there is no evidence of hydraulic leakage.

- **Tie Rod**
  - Ensure there are no loose or missing parts, tie rod end studs are locked and there is no visible damage.
- **Emergency Lowering Access Rod**
  - Ensure rod is properly secured and there is no visible damage.
- **Ladder**
  - Ensure there are no loose or missing parts and there is no visible damage.
- **Outriggers (If Equipped)**
  - Ensure there are no loose or missing parts and there is no visible damage.

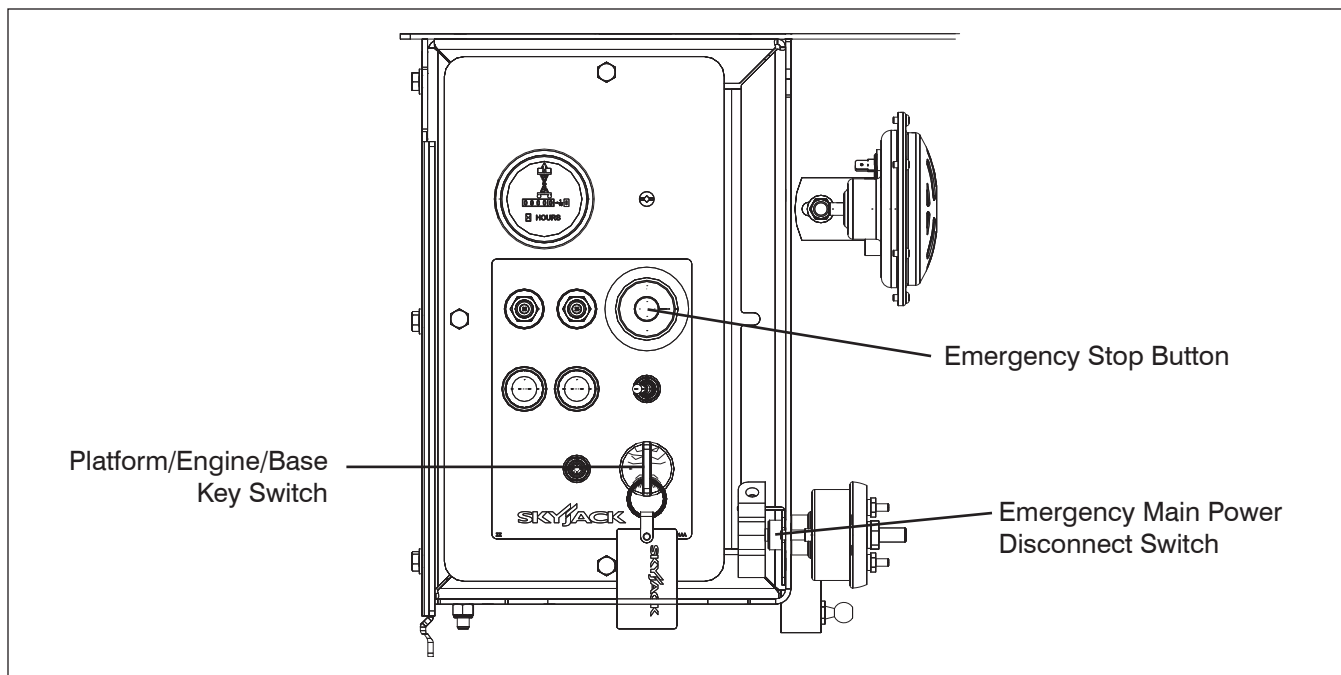

## 2.4 Function Tests

Function tests are designed to discover any malfunctions before aerial platform is put into service. The operator must understand and follow step-by-step instructions to test all aerial platform functions.

### IMPORTANT

**Never use a malfunctioning aerial platform. If malfunctions are discovered, aerial platform must be tagged and placed out of service. Repairs to aerial platform may only be made by a qualified service technician.**

After repairs are completed, operator must perform a pre-operation inspection and a series of function tests again before putting aerial platform into service.

Prior to performing function tests, be sure to read and understand [Section 3.8 - Start Operation](#).

### 2.4-1 Test Main Power Disconnect Switch

1. In engine compartment, turn emergency main power disconnect switch to “○” off position.  
**Result:** Aerial platform functions should not operate.

### 2.4-2 Base Control Console



### WARNING

**Ensure that you maintain three points of contact when using the ladder to mount/dismount platform.**

1. Use the ladder of aerial platform to access platform.
2. Close the gate.
3. On platform control console, pull out “●” emergency stop button.
4. Select low/high throttle switch to “⊖” low throttle position.
5. Use the ladder to dismount from platform.
6. Turn emergency main power disconnect switch to “I” on position.

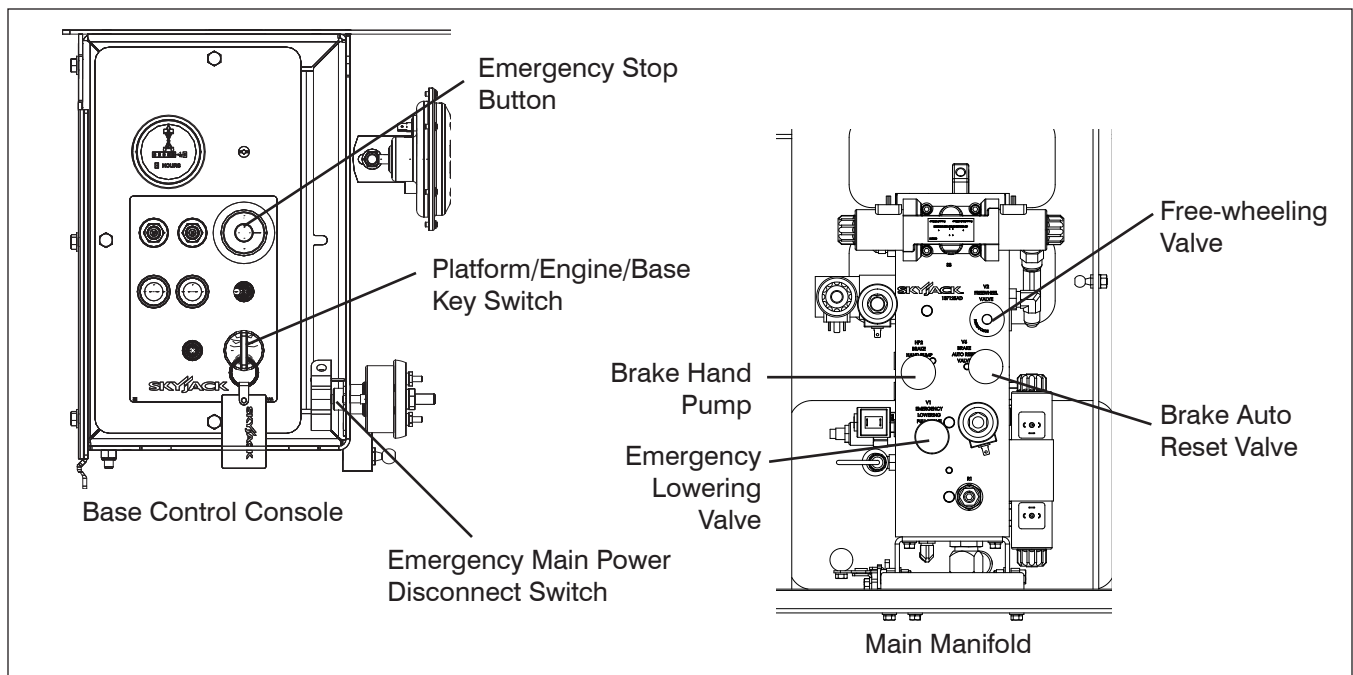



• **Test Platform/Engine/Base Key Switch**





**WARNING**



Be aware of overhead obstructions or other possible hazards around the aerial platform when lifting.

1. Pull out base “” emergency stop button.
2. Insert key into platform/engine/base key switch, select “” engine position and attempt to start engine.  
**Result:** Engine should not start.
3. With key inserted into platform/engine/base key switch, select “” base position and attempt to start engine.  
**Result:** Engine should start.

• **Test Emergency Stop**

1. Push in base “” emergency stop button.  
**Result:** Engine should shut down and aerial platform functions should not operate.
2. Pull out base “” emergency stop button and restart engine.

• **Test Platform Raise/Lower Switch**

1. Select platform/engine/base key switch to “” base position and raise or lower the platform with platform “” raise or “” lower switch.  
**Result:** Platform raising and lowering functions should operate.

• **Test Emergency Lowering**

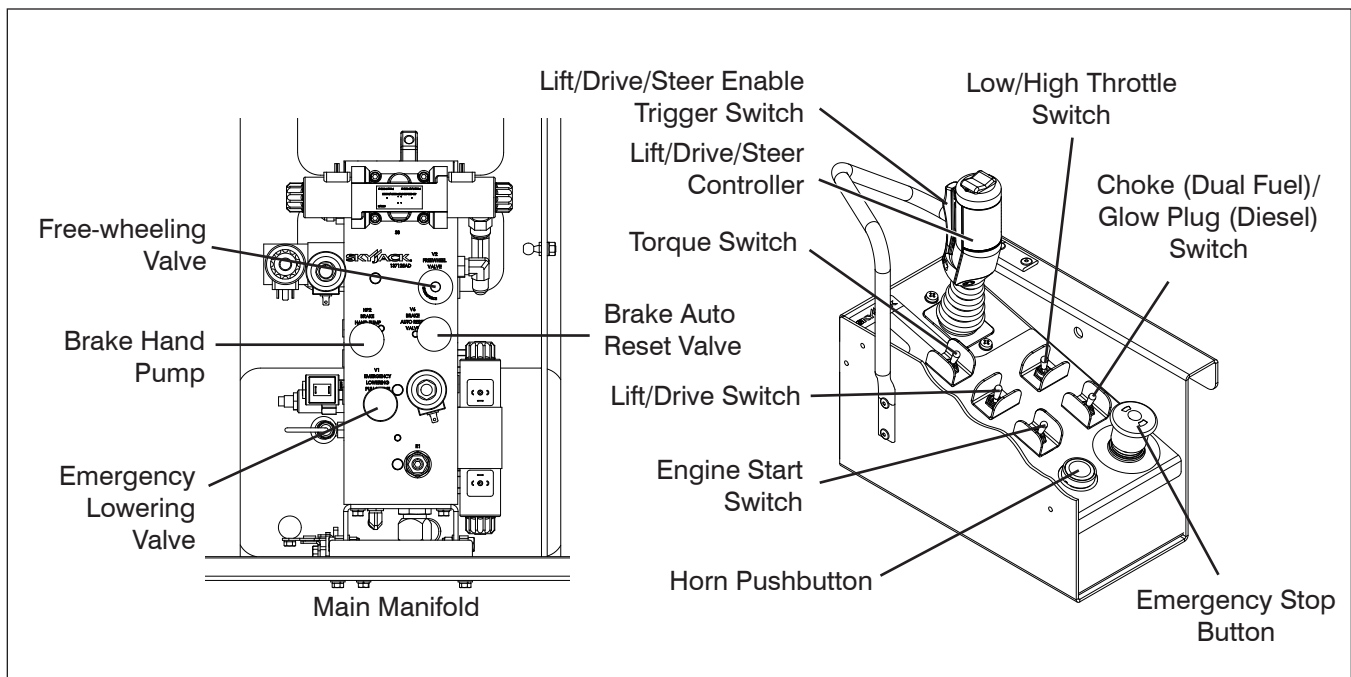

1. Raise the platform.
2. Locate holding valve manual override knob at the base of each lift cylinder. Depress and turn counterclockwise. If necessary, use access rod that is located on the base of the aerial platform.
3. On hydraulic/fuel compartment, pull out and hold emergency lowering valve to fully lower the platform.  
**Result:** The platform should lower.
4. To restore normal operation, depress and turn holding valve manual override knobs clockwise.



• **Test Free-wheeling**

1. Ensure path of intended motion is clear.
2. Release the brake manually (refer to [Section 2.5-2](#)).
3. Turn free-wheeling valve knob counterclockwise to a fully opened position and attempt to push/pull the aerial platform.  
**Result:** Aerial platform should move.
4. Turn free-wheeling valve knob clockwise to a fully closed position for normal operation.
5. Reengage the brake (refer to [Section 2.5-2](#)).

**2.4-3 Platform Control Console**

1. Ensure base “” emergency stop button is pulled out.
2. Ensure emergency main power disconnect switch is in “” on position.
3. Select platform/engine/base key switch to “” platform position and remove key.



**Ensure that you maintain three points of contact when using the ladder to mount/dismount platform.**

4. Use the ladder of aerial platform to access platform.
5. Close the gate.
6. On platform control console, pull out “” emergency stop button.

• **Test Emergency Stop**

1. Ensure engine is running.
2. Push in “” emergency stop button.  
**Result:** Engine should shut down and aerial platform functions should not operate.

• **Test Enable Trigger Switch**

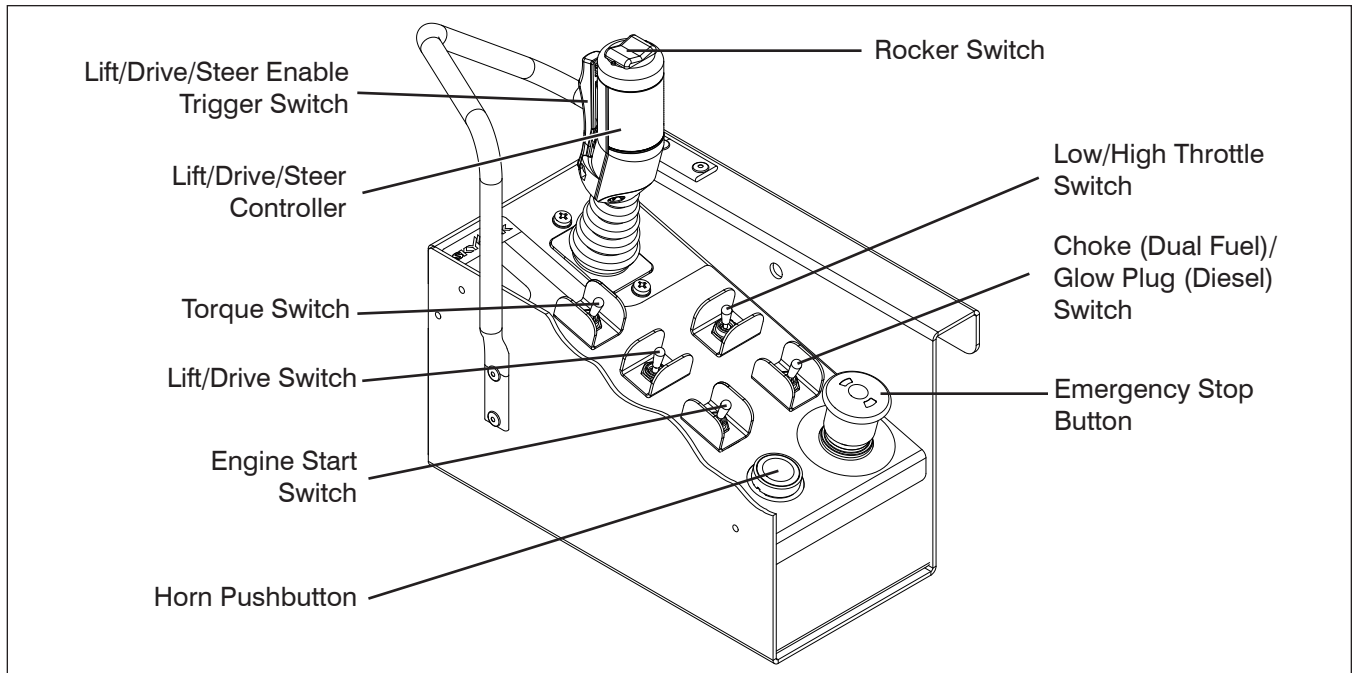

1. Ensure engine is running.
2. Without activating “” enable trigger switch, attempt to activate any platform function.  
**Result:** All platform functions should not operate.





• **Test Platform Raising/Lowering**



**WARNING**  
 Be aware of overhead obstructions or other possible hazards around the aerial platform when lifting.



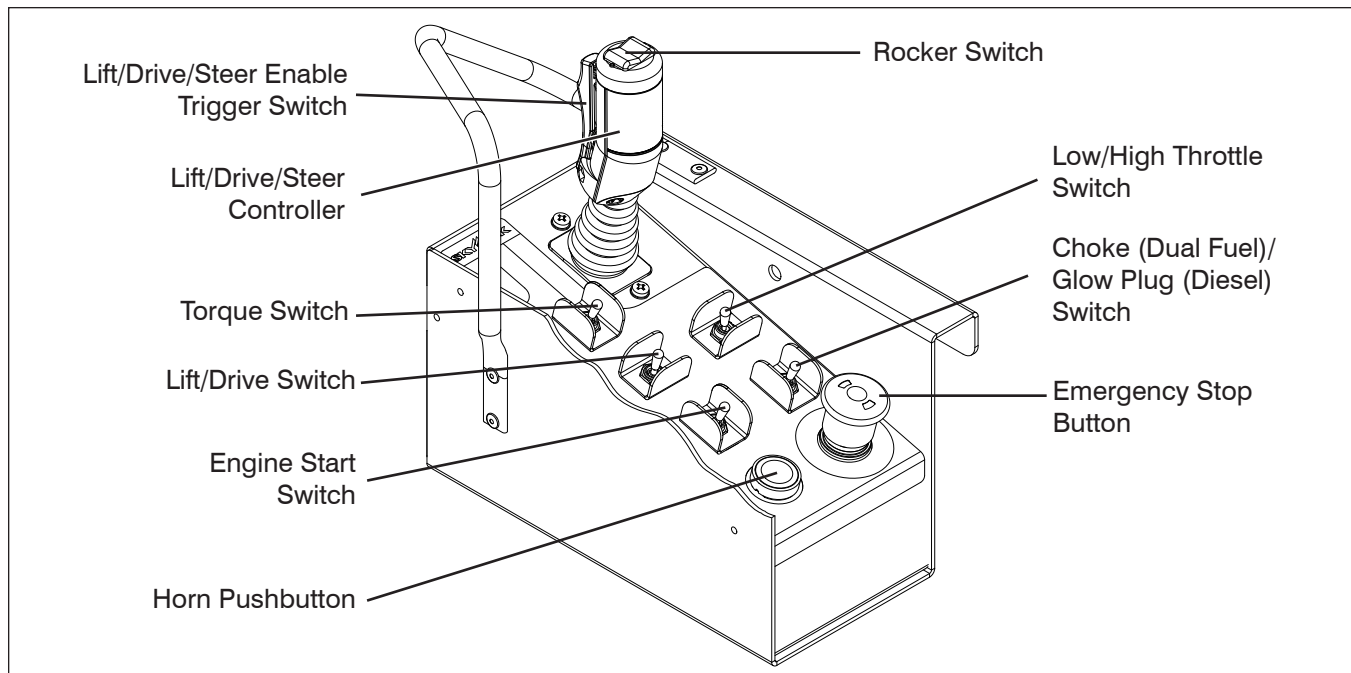

1. Select lift/drive switch to “” lift position.
2. Activate and hold “” enable trigger switch.
3. Push or pull controller handle until desired height is reached.  
**Result:** Platform raising and lowering functions should operate.

• **Test Steering**

1. Ensure engine is running.
2. Press rocker switch on top of controller to “” left and “” right.  
**Result:** Steer wheels should turn left and right.



- **Test Driving**

1. Ensure path of intended motion is clear.
2. On platform control console, select lift/drive switch to “” drive position.
3. Activate and hold “” enable trigger switch.
4. Slowly move controller in “” forward or “” reverse direction until aerial platform begins to move, and then return handle to center position.  
**Result:** Aerial platform should move in forward or reverse direction, and then come to a stop.

- **Test Speed Limit**



**WARNING**

**Be aware of overhead obstructions or other possible hazards around the aerial platform when lifting.**

1. Ensure path of intended motion is clear.
2. Raise the platform until approximately a height of 7 feet (2 meters) is reached and attempt to drive forward or reverse.  
**Result:** Aerial platform should move slower than when it is in stowed position.

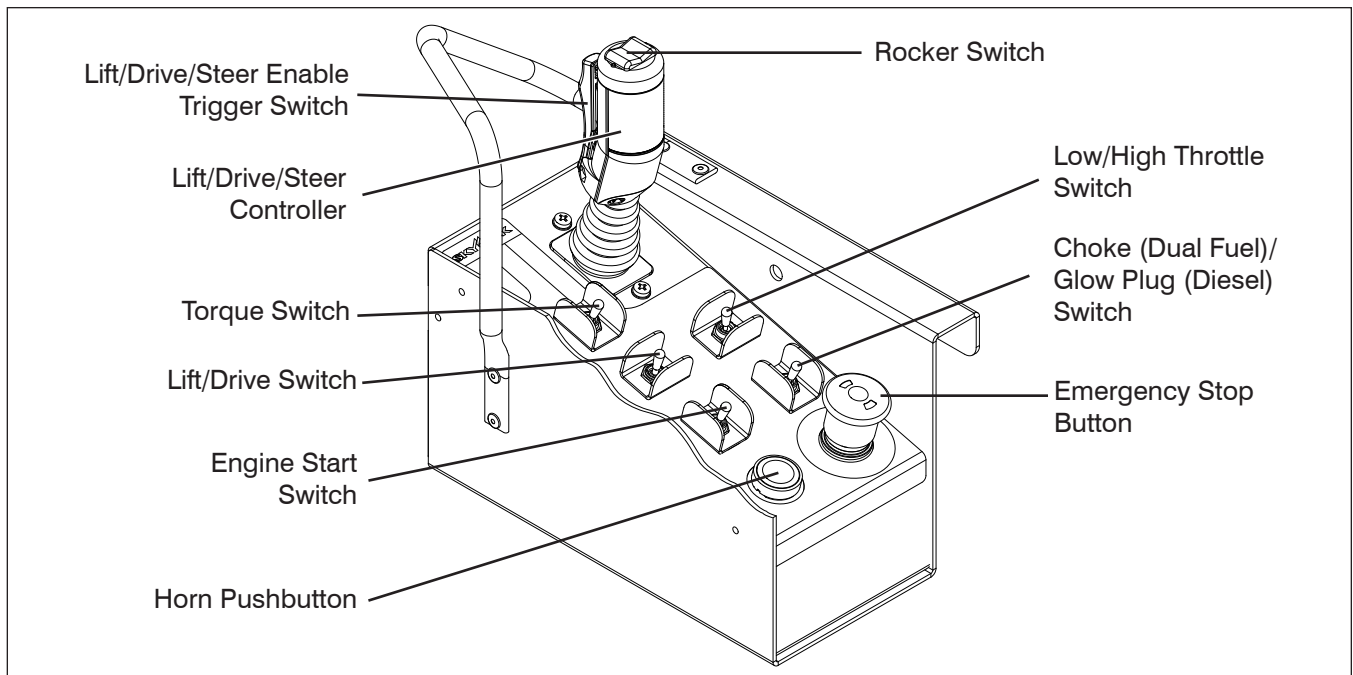





• **Test Brakes**



**WARNING**

**Brakes will engage instantly when you release the controller handle, causing aerial platform to stop immediately.**

1. Ensure path of intended motion is clear.
2. Activate and hold “” enable trigger switch.
3. Drive aerial platform “” forward. Test brake by releasing controller handle.  
**Result:** Aerial platform should come to a stop. If aerial platform pulls to one side while stopping, do not operate aerial platform until brake adjustments have been checked.
4. Drive aerial platform “” forward. Test brake again by releasing “” enable trigger switch only.  
**Result:** Aerial platform should come to an instant and abrupt stop. If aerial platform does not stop immediately, or if aerial platform pulls to one side while stopping, do not operate aerial platform until brake adjustments have been checked.

• **Test Horn**

1. Push “” horn pushbutton.  
**Result:** Horn should sound.



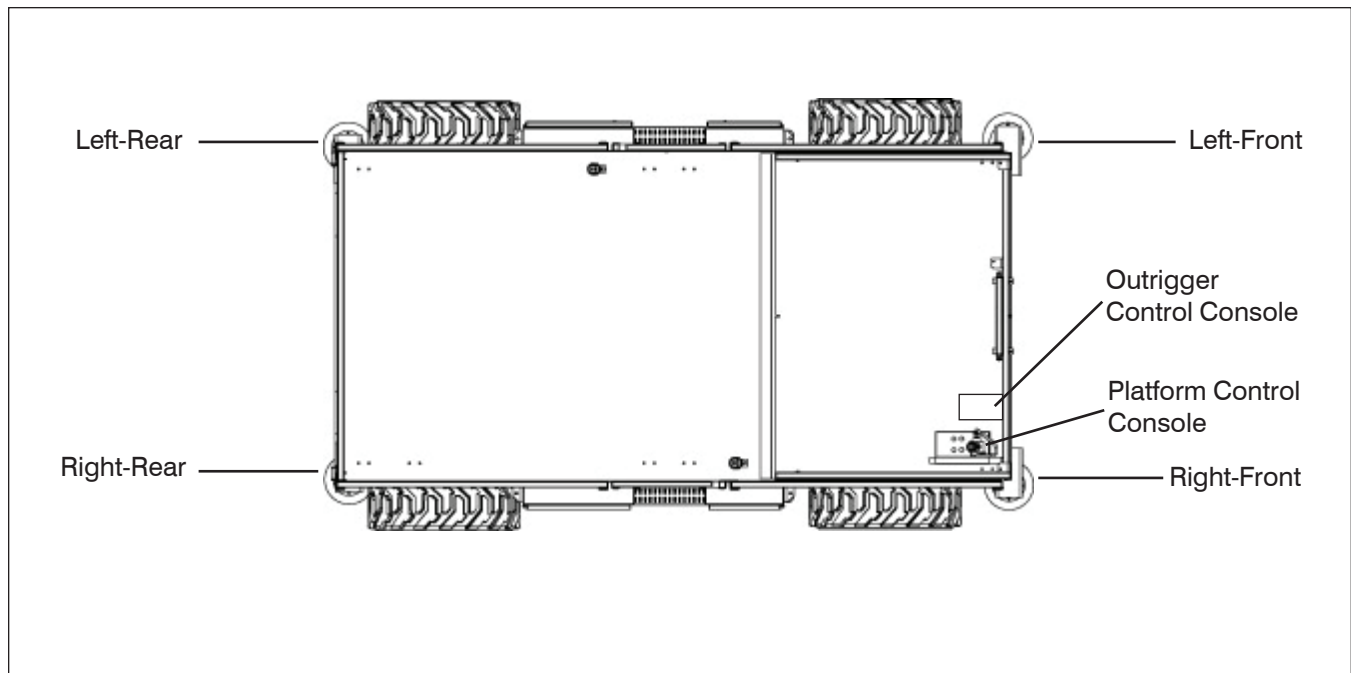

- **Test Hydraulic Outriggers (If Equipped)**  
(For Hydraulic Outrigger Operation, refer to [Section 3.8-9](#))

1. Ensure aerial platform is parked on a firm, level surface and free from obstructions.
2. Ensure platform is fully lowered.
3. Ensure outriggers are fully retracted.
4. Auto-level (If equipped):  
Use auto-level to extend outriggers.  
**Result:** All four outriggers will extend until they are supporting weight and bring machine to within level.
5. Once auto-level is complete, attempt to lift platform 1 foot and then lower the platform to stowed position.  
**Result:** Platform will lift and lower.
6. With platform at stowed position, fully retract all outriggers using auto-level.  
**Result:** All four outriggers will retract until they are in the stowed (up) position.

**WARNING**

Ensure that there are no personnel or obstructions in the path of travel, including blind spots.

7. Drive the aerial platform to maximum speed.  
**Result:** Aerial platform drives at high speed.

**WARNING**

Be aware of overhead obstructions or other possible hazards around the aerial platform when lifting or driving.

8. Lift platform to 12 feet (measured from the bottom of the tires to the platform surface) from stowed position.  
**Result:** Lift function will operate.
9. Drive aerial platform at raised height (12 feet).  
**Result:** Aerial platform drives at slow speed.
10. Attempt to operate outriggers at raised height (12 feet).
  - Attempt to partially extend Left-Front Outrigger (approximately 4").  
**Result:** Outrigger will not extend.
  - Attempt to partially extend Right-Front Outrigger (approximately 4").  
**Result:** Outrigger will not extend.

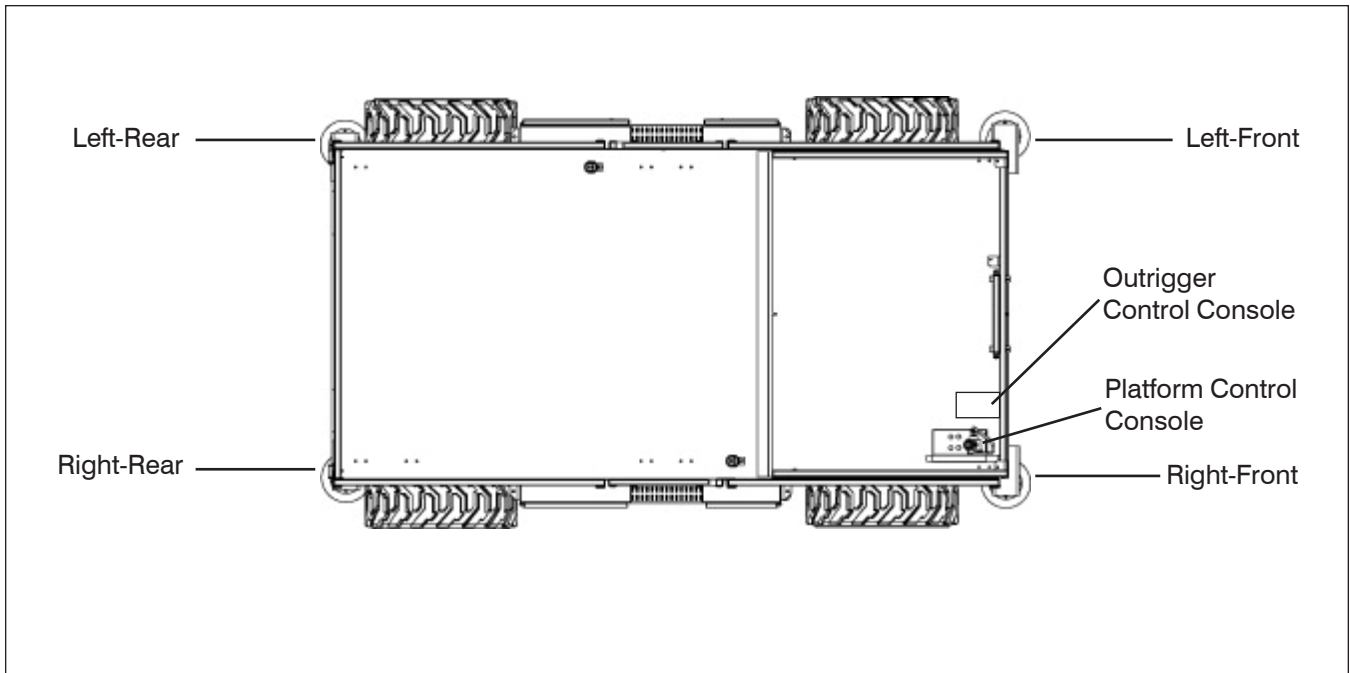

- Attempt to partially extend Right-Rear Outrigger (approximately 4").  
**Result:** Outrigger will not extend.
- Attempt to partially extend Left-Rear Outrigger (approximately 4").  
**Result:** Outrigger will not extend.
- With Right-Rear Outrigger partially extended, attempt to lift the platform.  
**Result:** Lift function will not operate.
- With Left-Rear Outrigger partially extended, attempt to lift the platform.  
**Result:** Lift function will not operate.

11. Lower the platform to stowed position.  
**Result:** Lower function will operate.

12. Raise the platform 1 foot from stowed position and partially extend Left-Front Outrigger (approximately 4").
- Attempt to lift the platform.  
**Result:** Lift function will not operate.
  - Attempt to drive the aerial platform.  
**Result:** Drive function will not operate.
  - Attempt to lower the platform.  
**Result:** Lower function will operate.

13. Platform at stowed position.
- With Left-Front Outrigger partially extended, attempt to lift the platform.  
**Result:** Lift function will not operate.
  - With Right-Front Outrigger partially extended, attempt to lift the platform.  
**Result:** Lift function will not operate.

14. Platform at stowed position.
- Extend each outrigger until it raises the tires up approximately 2".
  - Retract the Left-Front Outrigger until the weight is resting on the corresponding tire.
  - Extend the Right-Rear Outrigger until it makes contact with ground.
  - Attempt to lift the platform 1 foot.  
**Result:** Lift function will not operate.

15. Platform at stowed position.
- Extend each outrigger until it raises the tires up approximately 2".
  - Retract the Right-Front Outrigger until the weight is resting on the corresponding tire.
  - Extend the Left-Rear Outrigger until it makes contact with ground.

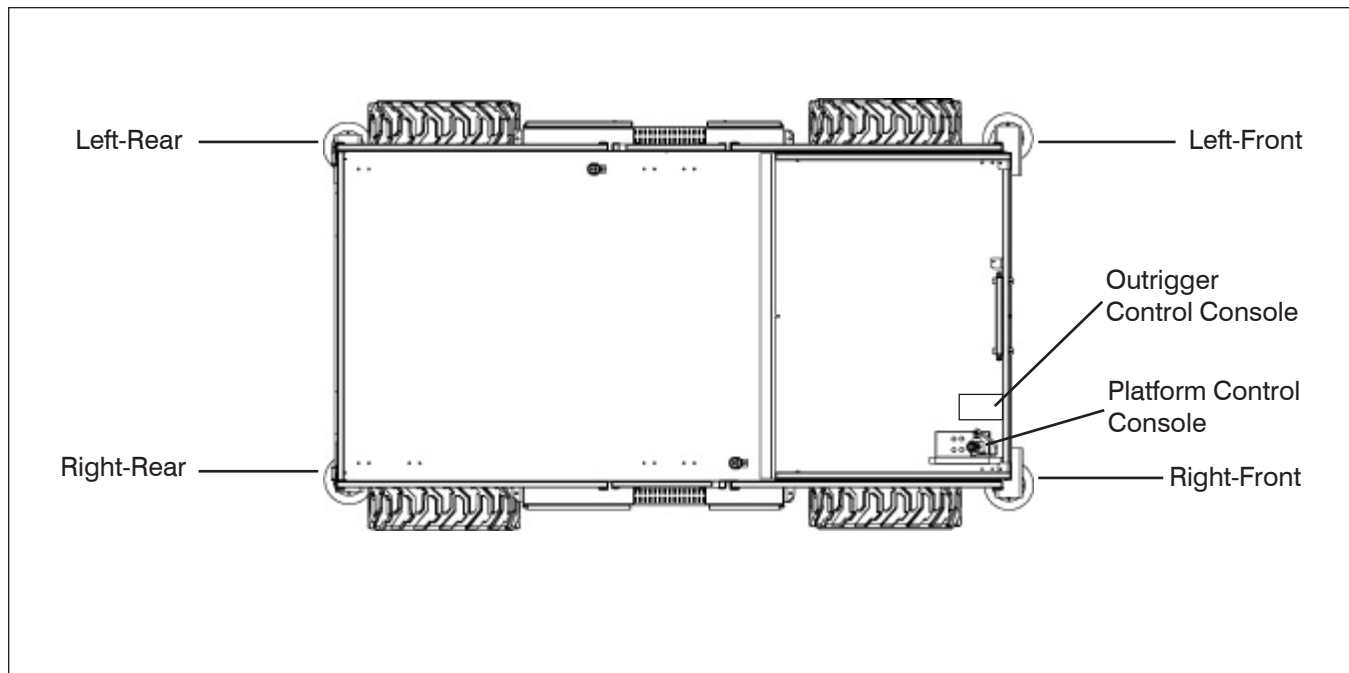

- Attempt to lift the platform 1 foot.  
**Result:** Lift function will not operate.
16. Platform at stowed position.
- Extend each outrigger until it raises the tires up approximately 2".
  - Retract the Right-Rear Outrigger until the weight is resting on the corresponding tire.
  - Extend the Left-Front Outrigger until it makes contact with ground.
  - Attempt to lift the platform 1 foot.  
**Result:** Lift function will not operate.
17. Platform at stowed position.
- Extend each outrigger until it raises the tires up approximately 2".
  - Retract the Left-Rear Outrigger until the weight is resting on the corresponding tire.
  - Extend the Right-Front Outrigger until it makes contact with ground.
  - Attempt to lift the platform 1 foot.  
**Result:** Lift function will not operate.
18. Extend all four outriggers until all tires are off the ground and the aerial platform is levelled.
- Lift the platform to 12 feet.  
**Result:** Lift function will operate.
  - Lower the platform from raised height (12 feet).  
**Result:** Lower function will operate.

**WARNING**

If any outrigger interlocks fail to operate in the expected manner, the aerial platform should be tagged and removed from operation immediately.

**WARNING**

Repairs to the aerial platform may only be made by a qualified service technician.

**2.5 Winching and Towing Procedure**

This section provides the operator with procedure about winching and towing and how to release the brakes.



**WARNING**

Ensure platform is fully lowered before winching or towing. Sudden motion could cause the aerial platform to become unstable. Death or serious injury could result.



**WARNING**

In emergency situations where aerial platform functions are not available and lowering is impeded by an obstacle, utmost care must be taken to move aerial platform far enough to clear obstacle. In such cases, operation must be extremely smooth with no sudden movements and must not exceed a speed of 2"/sec (50 mm/sec).



**WARNING**

When pushing, winching or towing, do not exceed 2 mph (3.2 km/h).



**WARNING**

Do not push, winch or tow aerial platform onto a slope, or brake the towing vehicle rapidly. Do not pull aerial platform down an incline towards a winch.

**2.5-1 To Release Free-wheeling Valve**

1. Ensure aerial platform is on level ground. Chock or block the wheels to prevent aerial platform from rolling.

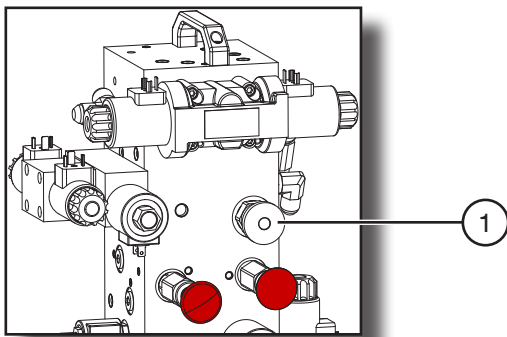

Figure 2-9. Free-wheeling Valve

2. **Free-wheeling Valve** - Turning the valve knob counterclockwise (item 1) to a fully opened position allows fluid to flow through the wheel motors, thus providing "free-wheeling".



**WARNING**

The free-wheeling valve must be closed tightly (clockwise) for normal operation.

**2.5-2 To Release Brakes Manually**

Releasing the brakes manually depends on the brake system that is provided on the aerial platform.



**WARNING**

Do not manually disengage brakes if the aerial platform is on a slope.

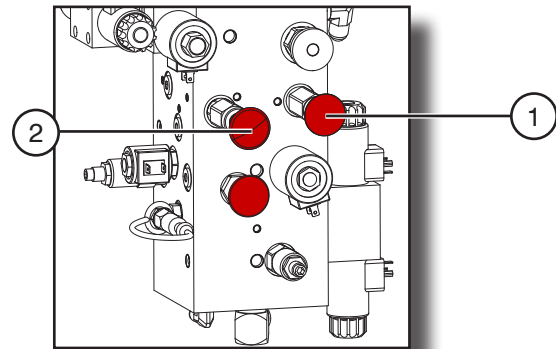

Figure 2-10. Disc Brakes System

**NOTE**

Brakes must be manually disengaged for pushing, winching or towing.

1. Ensure aerial platform is on level ground. Chock or block wheels to prevent aerial platform from rolling.
2. Turn emergency main power disconnect switch to "O" off position.
3. Locate brake auto reset valve plunger (item 1) and brake hand pump (item 2) at the main manifold in the hydraulic/fuel compartment.
4. Push in brake auto reset valve plunger.
5. Grasp brake hand pump and rapidly depress until firm resistance is felt. The brakes are now released.

- Remove wheel chocks or blocks, then push, winch or tow aerial platform to desired location.

**WARNING**

**Brakes must be reengaged immediately after reaching the desired location.**

- Position aerial platform on a firm and level surface.
- Chock or block wheels to prevent aerial platform from rolling.
- Reengage brakes by pulling out brake auto reset valve plunger.

## 2.6 Emergency Lowering Procedure

This section guides the operator on how to use emergency lowering system. This system allows platform lowering in the event of an emergency or an engine malfunction.

**WARNING**

**Keep clear of scissors mechanism when using emergency lowering valve.**

- Remove any obstructions from a descending platform.
- Extension platform(s) may need to be retracted or aerial platform may need to be moved to clear obstruction. Refer to [Section 2.5](#) for winching and towing procedures.

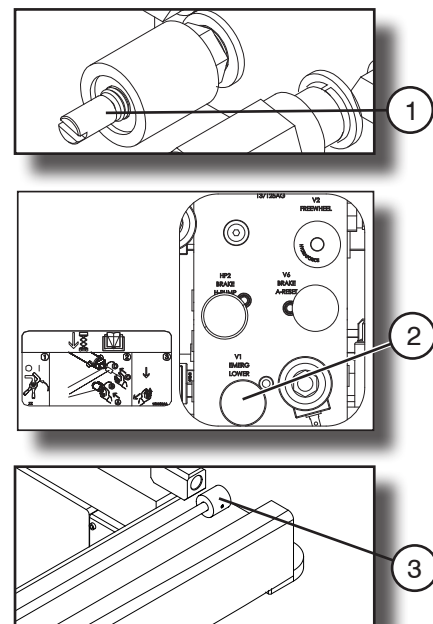

Figure 2-11. Emergency Lowering System

- Locate holding valve override knob (item 1) at base of each lift cylinder. Depress and turn counterclockwise (1/4 turn). If necessary, use emergency lowering access rod (item 3) located on aerial platform base.
- On the hydraulic/fuel compartment, pull out and hold emergency lowering pull valve (item 2) to lower platform.
- To restore normal operation, depress and turn the holding valve override knobs clockwise.



## 3.0 Operation

This section provides the necessary information needed to operate the aerial platform. It is important that the user reads and understands this manual before operating the aerial platform.

### 3.1 General

In order for this aerial platform to be in good working condition, it is important that the operator meets the necessary qualifications and follow the maintenance and inspection schedule referred to in this manual.

#### 3.1-1 Operator Qualifications

- Only trained and authorized personnel shall be permitted to operate an aerial platform.
- Safe use of this aerial platform requires the operator to understand the limitations and warnings, operating procedures and operator's responsibility for maintenance. Accordingly, the operator must understand and be familiar with this operating manual, its warnings and instructions, and all warnings and instructions on the aerial platform.
- The operator must be familiar with employer's work rules and related government regulations and be able to demonstrate the ability to understand and operate this make and model of aerial platform in the presence of a qualified person.

#### 3.1-2 Operator's Responsibility for Maintenance



#### **WARNING**

**Maintenance must be performed by trained and competent personnel who are familiar with mechanical procedures.**

**Death or serious injury could result from the use of an aerial platform that is not properly maintained or kept in good working condition.**

- The operator must be sure that the aerial platform has been properly maintained and inspected before using it.
- The operator must perform all the daily inspections and function tests found in [Table 4.6](#), even if the operator is not directly responsible for the maintenance of this aerial platform.

#### 3.1-3 Maintenance and Inspection Schedule

- The inspection points covered in [Table 4.6](#) indicate the areas of the aerial platform to be maintained or inspected and at what intervals the maintenance and inspections are to be performed.
- The actual operating environment of the aerial platform may affect the maintenance schedule.



#### **WARNING**

**Use original or manufacturer-approved parts and components for the aerial platform.**

#### 3.1-4 Owner's Inspections

It is the responsibility of the owner to arrange daily, quarterly (or 150 hours) and annual inspections of the aerial platform. Refer to [Table 4.6](#) for recommended maintenance and inspection areas and intervals. A record of annual inspection is kept on a label located on the scissor assembly. Refer to [Table 4.3](#) in this manual.

3.2 Major Components

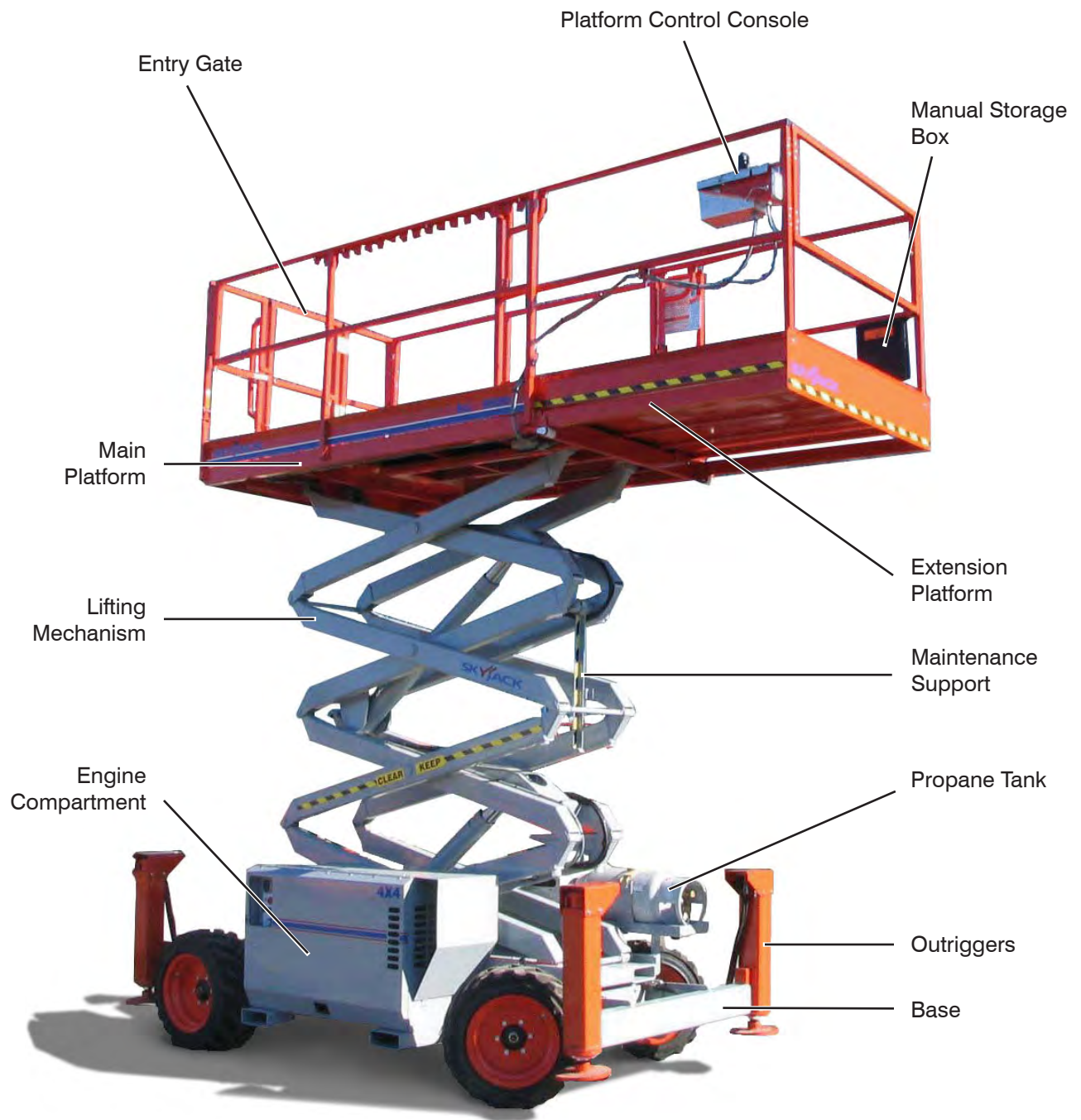

SKYJACK Model SJ 6826RT Aerial Platform



### 3.3 Major Assemblies

The aerial platform consists of three major assemblies: base, lifting mechanism and platform.

#### 3.3-1 Base

The base is a rigid, one-piece weldment which supports two side compartments.

- One compartment contains the engine, 12V battery, base control console and electrical components. The other compartment contains the emergency lowering system, brake release and hydraulic components as well as fuel and hydraulic tanks.
- The propane cylinders (if equipped) are located on both sides of the hydraulic/fuel compartment.
- The four wheels are hydraulically-motor driven with two front wheels steerable by a hydraulic cylinder.
- The rear wheel motors have spring-applied hydraulically released disc brakes.

#### 3.3-2 Lifting Mechanism

The lifting mechanism is constructed of formed steel or tube sections making up a scissor-type assembly. The scissor assembly is raised and lowered by single-acting hydraulic lift cylinders with holding valves. A two-section pump, driven by an engine, provides hydraulic power to the lift cylinders.

#### 3.3-3 Platform

The platform is constructed of a tubular support frame, a skid-resistant “diamond plate” deck surface and 39” hinged guardrails with 6” toe boards and mid-rails. The platform can be entered from the rear through a spring returned gate with latch. The platform is also equipped with a manual extension platform. A 110V outlet is also located on the platform.

### 3.4 Serial Number Nameplate

The serial number nameplate, located at the rear of the aerial platform, lists the following:

- Model number
- Serial number
- Aerial platform weight
- Maximum drivable height
- Maximum capacities
- Maximum number of persons permissible on the platform
- Voltage
- System pressure
- Lift pressure
- Maximum platform height
- Maximum wheel load

### 3.5 Component Identification

The following descriptions are for identification, explanation and locating purposes only.

#### 3.5-1 Manual Storage Box

This weather-resistant box is mounted on the platform railings. It contains the operating manual, ANSI/CSA certificate and other important documentation. The operating manual for this make and model of aerial platform must remain with the aerial platform and should be stored in this box.



#### 3.5-2 Maintenance Support

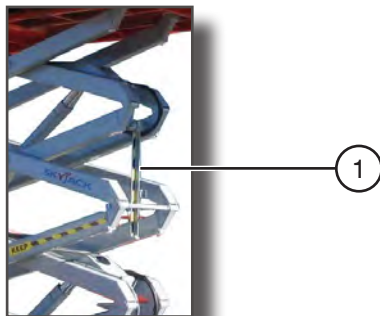

Figure 3-1. Maintenance Support

1. **Maintenance Support** - The maintenance support is a safety mechanism designed to support the scissor assembly. When properly positioned, it can support the scissor assembly and empty platform. The maintenance support must be used when inspection and/or maintenance is to be performed within the lifting mechanism. Refer to [Section 3.13](#) for how to use the maintenance support.



#### **WARNING**

The maintenance support must be used when inspection and/or maintenance or repairs are to be performed within the lifting mechanism. Failure to use this safety mechanism could result in death or serious injury.



#### **WARNING**

Do not reach through the scissor assembly when the platform is raised without the maintenance support properly positioned. Failure to avoid this hazard could result in death or serious injury.

### 3.5-3 Folding Guardrail System

This system, when folded down, reduces the height of the retracted aerial platform for transporting and traveling through doorways only. Refer to [Section 3.10](#) for guardrail folding procedure.



#### WARNING

The scissor assembly must be fully lowered before raising or lowering the guardrails.



#### WARNING

Any lowered guardrail will create a fall hazard. Remain away from the sides of the platform while raising or lowering the guardrails to avoid falling. Refer to [Section 3.10](#), for guardrail folding procedure.

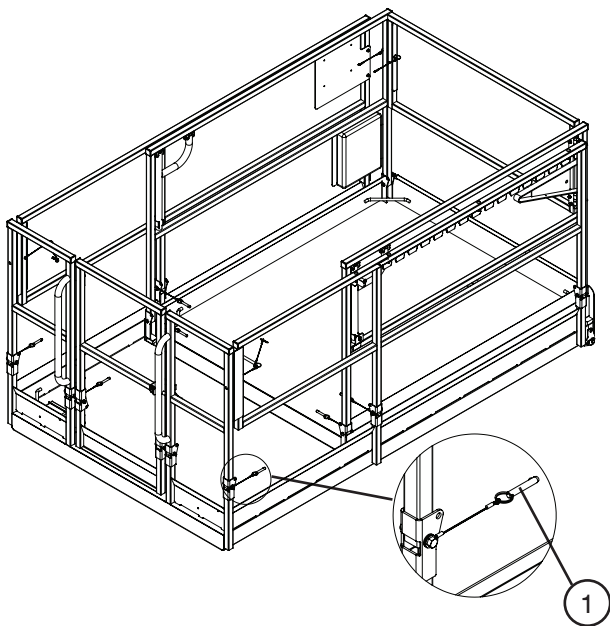

Figure 3-2. Folding Guardrail System

1. **Guardrail Locking Pin with Lanyard** - This pin is used to lock the guardrail in place.



#### WARNING

Before operating this aerial platform check the guardrail system for loose or missing locking pins. The guardrail system must be upright and all pins must be locked in place.

Death or serious injury could result if the guardrail system is not upright or properly locked.

### 3.5-4 Safety Belt/Harness Attachment Bar

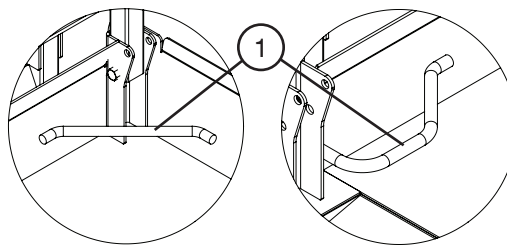

Figure 3-3. Safety Belt/Harness Attachment Bar

1. **Lanyard Attachment Anchorage** - Use this as an attachment point for safety belt/harness tethers. Do not attach belts/harnesses to any other point on the platform. Do not use this to lift, anchor, secure or support the platform or any other apparatus or material.



#### WARNING

The lanyard attachment anchorage is used for travel restraint, within the limits of the platform only. It is not a fall arresting device! Used as such could result in death or serious injury.

### 3.6 Component Identification (Optional Equipment/Attachments)

This section describes the components that are optional to aerial platforms.

#### 3.6-1 Outrigger/Generator Control Console (Auto-Leveling) (If Equipped)

The outrigger/generator control console is located next to the platform control console. These switches control the generator, and outriggers' extension and retraction.

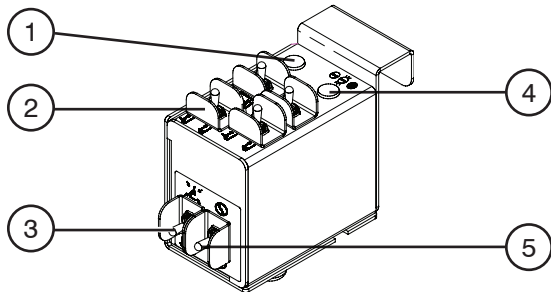









Figure 3-4. Outrigger/Generator Control Console with All Options

1. **Generator Switch** - This switch activates the generator.
2. **Outrigger Extend/Retract Switches** - These switches control the extension or retraction of each individual outrigger.
3. **Auto-Level Switch** - In the “” extend position, each outrigger extends and automatically adjusts until aerial platform is level. In the “” retract position, the outriggers retract.
4. **Outrigger Enable Switch** - This “” outrigger enable switch, when in the extend or retract position, activates functions on the auto-level switch and outrigger extend/retract switches.

5. **Leveling Indicator Light** - This light illuminates to display the status of the outriggers when the auto and manual level functions are in use. The indicator light has the following states:

-  **Off:** The outriggers are fully retracted.
-  **Flashing Rapidly:** The outriggers are extending but the platform is not level.
-  **Flashing:** The outriggers are extended but the platform is not yet level.
-  **Solid:** The outriggers are extended and the platform is level.

#### 3.6-2 800W AC Inverter (If Equipped)

The inverter is located on the base of the aerial platform. It has the following controls:

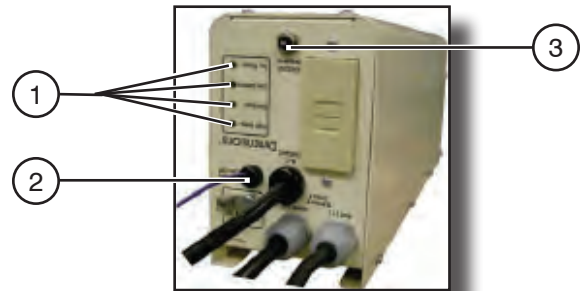

Figure 3-5. 800W AC Inverter

**NOTE**

The inverter operation is automatic. These controls do not need to be manipulated for normal operation.

1. **Status LEDs** - These LEDs indicate the operating or fault status of the inverter.
2. **On/Off Wire** - This wire is the connection to turn the inverter on.
3. **15 Amp Circuit Breaker** - In the event of a power overload or circuit grounding, the circuit breaker will pop out. Ensure the overload is removed. Push the breaker back in to reset.
4. **GFCI Outlet** - During inverter operation, this outlet provides AC power.

### 3.6-3 Tire Sealant (If Equipped)

This option is identified with a tire sealant label located at the rim of the wheel.

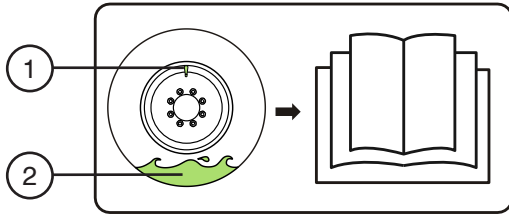

Figure 3-6. Tire Sealant Label

**Tire Sealant Label** - This label indicates that tire sealant is present inside the tires.

1. **Tire Valve Stem Cap** - This green valve stem cap is substituted onto air tires to indicate sealant has been installed.
2. **Sealant** - This symbol signifies that the tire is equipped with sealant.



#### **WARNING**

**The operator MUST properly handle tires with sealant.**

- **When depressurizing, inflating or checking tire pressure, ensure that the valve stem is at the top to prevent sealant from entering the stem (refer to Figure 3-6).**
- **If the tire no longer holds pressure, replace the tire.**



#### **WARNING**

**The sealant contains propylene glycol. Do not ingest, inhale or get into eyes. If it gets into your eyes, flush with water for 15 minutes. Consult physician.**

### 3.7 Operator's Responsibility

It is the responsibility of the operator, prior to each work shift, to perform the following:

#### 1. Visual and Daily Maintenance Inspections

- are designed to discover any damage of components before the aerial platform is put into service.
- are done before the operator performs the function tests.



#### **WARNING**

**Failure to locate and repair damage, and discover loose or missing parts may result in an unsafe operating condition.**

#### 2. Function Tests

- are designed to discover any malfunctions before the aerial platform is put into service.

#### **IMPORTANT**

**The operator must understand and follow the step-by-step instructions to test all aerial platform functions.**

The operator should make a copy of the Operator's Checklist (see [Table 4.7](#)) and fill out the visual and daily maintenance inspections and the function tests sections while performing the items outlined in [Section 2.3](#) and [Section 2.4](#).

#### **IMPORTANT**

**If aerial platform is damaged or any unauthorized variation from factory-delivered condition is discovered, aerial platform must be tagged and removed from service.**

Repairs to the aerial platform may only be made by a qualified service technician. After repairs are completed, the operator must perform visual and daily maintenance inspections & function tests again.

Scheduled maintenance inspections shall only be performed by qualified service technician (see [Table 4.6](#)).

### 3.8 Start Operation

Carefully read and completely understand the operating manual and all warnings and instruction labels (refer to [Section 5 - Labels](#)) on the aerial platform.



#### **WARNING**

**Do not operate this aerial platform without proper authorization and training. Failure to avoid this hazard could result in death or serious injury.**

Before operating this aerial platform, perform the following steps:

1. Visual and daily maintenance inspections (see [Section 2.3](#))
2. Function tests (see [Section 2.4](#))
3. Jobsite inspection

It is the responsibility of the operator to perform a jobsite inspection and avoid the following hazardous situations:

- holes or drop-offs
- ditches or soft fills
- floor obstructions, bumps or debris
- overhead obstructions
- electrical cords, hoses and high voltage conductors
- hazardous locations
- inadequate surface support to withstand all load forces imposed by the aerial platform
- wind and weather conditions
- the presence of unauthorized personnel
- other possible unsafe conditions



#### **WARNING**









**An operator should not use any aerial platform that:**

- does not appear to be working properly.
- has been damaged or appears to have worn or missing parts.
- has alterations or modifications not approved by the manufacturer.
- has safety devices which have been altered or disabled.

**Failure to avoid these hazards could result in death or serious injury.**



**3.8-1 To Activate Base Control Console****WARNING**

**Ensure that you maintain three points of contact when using the ladder to mount/dismount platform.**

1. Use the ladder of aerial platform to access platform.
2. Close the gate.
3. On platform control console, pull out "  " emergency stop button.
4. Select low/high throttle switch to "  " low throttle position.
5. Use the ladder to dismount from platform.
6. Turn emergency main power disconnect switch to "I" on position.
7. On base control console, pull out "  " emergency stop button.
8. For dual fuel engines, select fuel supply by moving fuel switch to either "  " gasoline or "  " liquid propane gas position.
9. Insert key into platform/engine/base key switch and select "  " base position.
10. For cold dual fuel engines, depress and hold "  " choke pushbutton. For cold diesel engines, depress and hold "  " glow plug pushbutton for 15 to 20 seconds.

**CAUTION**

**Do not start the engine in the high throttle position.**

11. Depress and hold "  " engine start pushbutton until engine starts, then release. Do not overcrank starter. Release "  " choke pushbutton after engine starts (dual fuel).

**NOTE**



Choke is only active while button is depressed. Occasional use of choke button may be necessary during the first few seconds of engine operation.

**3.8-2 To Raise or Lower Platform Using Base Control Console****WARNING**

**Be aware of overhead obstructions or other possible hazards around the aerial platform when lifting.**





**WARNING**

**Do not lower the platform unless the area below is clear of personnel and obstructions.**

1. Activate base control console (refer to [Section 3.8-1](#)).
2. On base control console, select and hold "  " base position on platform/engine/base key switch. Select and hold platform raise/lower switch to either "  " raise or "  " lower position. Release switch to stop.







**3.8-3 To Activate Platform Control Console**

1. Turn emergency main power disconnect switch to “I” on position.
2. On the base control console, pull out the “” emergency stop button.
3. For dual fuel engines, select fuel supply by moving fuel switch to either “” gasoline or “” liquid propane gas position.
4. Insert key into platform/engine/base key switch and turn it to “” enable platform controls.



**WARNING**

**Ensure that you maintain three points of contact when using the ladder to mount/dismount platform.**

5. Use the ladder of aerial platform to access platform.
6. Close the gate.
7. On platform control console, pull out “” emergency stop button.
8. Turn the low/high throttle switch to “” low throttle position.
9. For cold dual fuel engines, select and hold “” choke switch. For cold diesel engines, select and hold “” glow plug switch for 15 to 20 seconds.

**CAUTION**

**Do not start the engine in the high throttle position.**





10. Select and hold “” engine start switch until engine starts, then release. Do not overcrank starter. Release “” choke switch after engine starts (dual fuel).

**3.8-4 To Raise or Lower Platform Using Platform Control Console****WARNING**

**Be aware of overhead obstructions or other possible hazards around the aerial platform when lifting.**

**WARNING**

**Do not lower the platform unless the area below is clear of personnel and obstructions.**

1. Activate platform control console (refer to Section 3.8-3).
2. On platform control console, select lift/drive switch to “” lift position.
3. Activate and hold “” enable trigger switch.
4. Move controller handle forward “” to raise or backward “” to lower the platform, until desired height is reached.
5. Return controller to neutral center position to stop. Release enable trigger switch.

**NOTE**

Lowering is not proportional.

**WARNING**

**To protect against unintended movement of the aerial platform, push in the emergency stop button after you have arrived at your desired location or elevation.**

**NOTE**





If the tilt alarm sounds and the platform does not, or only partially raises, immediately lower the platform completely and ensure that the aerial platform is on a firm, level surface.

**3.8-5 To Drive Forward or Backward****WARNING**

Be aware of blind spots when operating the aerial platform.

**WARNING**



Ensure that there are no personnel or obstructions in the path of travel, including blind spots.

1. Activate platform control console (refer to [Section 3.8-3](#)).
2. On platform control console, select lift/drive switch to “” drive position.
3. Activate and hold “” enable trigger switch.
4. Move controller handle “” forward or “” backward to desired speed and direction of platform travel.
5. Return controller to neutral center position to stop.  
Release “” enable trigger switch.

**WARNING**

To protect against unintended movement of the aerial platform, push in the emergency stop button after you have arrived at your desired location or elevation.

**3.8-6 To Steer**

1. Activate platform control console (refer to [Section 3.8-3](#)).
2. On the platform control console, turn lift/drive switch to “” drive position.
3. Activate and hold “” enable trigger switch.
4. Press “” rocker on top of controller handle in either direction to steer.

**NOTE**

Steering is not proportional. Driving and steering may be active at the same time.

### 3.8-7 To Select Drive Torque

1. **High Torque:** Select high torque when climbing grades, traveling on rough terrain or when loading or unloading aerial platform. To activate high torque, select torque switch to “” high torque (low speed) position.



#### **WARNING**

**Aerial platform must be in fully retracted position when operated on any grade. Driving while elevated on any grade may result in death or serious injury.**

2. **Low Torque:** Select low torque when traveling on flat surface. To activate low torque, select torque switch to “” low torque (high speed) position.



#### **WARNING**

**To protect against unintended movement of the aerial platform, push in the emergency stop button after you have arrived at your desired location or elevation.**

### 3.8-8 To Extend or Retract Manual Extension Platform

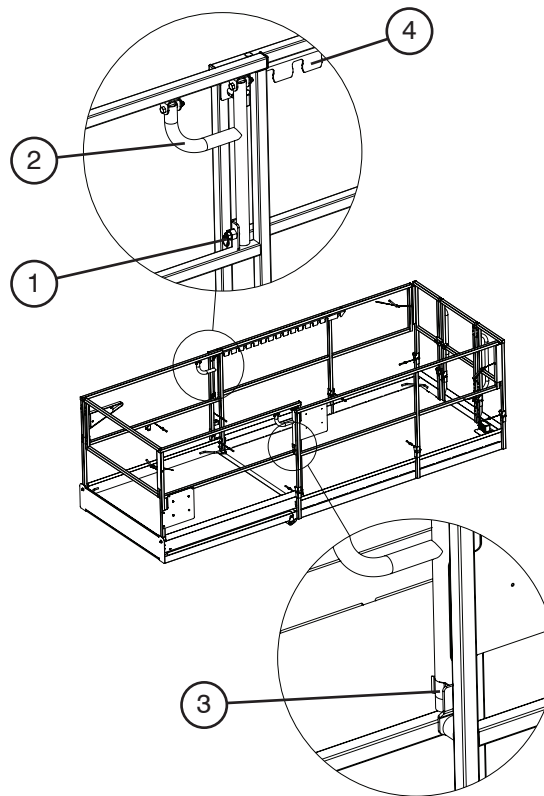

Figure 3-7. Manual Extension Platform

1. To extend/retract manual extension platform, pull out the pull pin (item 1), lift push bars (item 2) up from the gripper clip (item 3) then push/pull the push bar handle until desired extension/retraction is reached.
2. Ensure push bar rests in one of the slots in the extension interval (item 4). Fasten push bar down into the gripper clip and ensure pull pin is locked in place.



**3.8-9 Hydraulic Outriggers (If Equipped)**

These devices are mounted to four corners of the base. When properly positioned, they increase the stability of the aerial platform.





**3.8-9a Before Operation**

1. Move around aerial platform to check overhead clearances and ground obstructions.
2. To lower the platform completely, refer to [Section 3.8-2](#). Outrigger controls are not functional when platform is raised.
3. Check that the supporting surface under the tires and outrigger pads is firm and capable of supporting aerial platform and rated load. Do not place outrigger pad on a street drain, manhole cover or other unsupported surface.

**3.8-9b To Extend Outriggers**

4. On outrigger/generator control console, select and hold “” enable switch to provide power to outrigger circuit.
5. **Auto Extension:** Select auto-level switch to “” extend position until leveling indicator light stops flashing and remains in a solid state. Aerial platform should be completely supported by the outriggers and level at this point.

**Manual Extension:** Select corresponding outrigger extend/retract switch to “” extend position until platform is fully supported by outriggers and is level. The indicator light flashes while platform is being leveled and remains solid once platform is level. The indicator light has the following states:

-  **Off:** The outriggers are fully retracted.
-  **Flashing Rapidly:** The outriggers are extending but the platform is not level.
-  **Flashing:** The outriggers are extended but the platform is not yet level.
-  **Solid:** The outriggers are extended and the platform is level.

6. Ensure each outrigger pad is in firm contact over its entire surface area, with a suitable supporting surface! Make adjustments if necessary using manual outrigger controls.
7. Operate all non drive functions as described in their respective sections.

**NOTE**

Each outrigger pad must be in firm contact with the ground for most aerial platform functions to work.

**NOTE**



Drive functions are disabled if the outriggers are in any position other than fully retracted.



**WARNING**

**If alarm sounds during operation, the aerial platform is not level or an outrigger does not have firm ground contact. Lower the platform immediately! Make the necessary adjustments to level the aerial platform.**

**3.8-9c To Retract Outriggers**

8. On outrigger/generator control console, select and hold “” enable switch to provide power to outrigger circuit.
9. **Auto Retraction:** Select auto-level switch to “” retract position until outriggers are fully retracted.

**Manual Retraction:** Select corresponding pairs of outrigger extend/retract switch to “” retract position until outriggers are fully retracted.

**NOTE**

Limit switches are used to protect outriggers from being damaged. If drive functions are not available, visually check to see that all outriggers are fully retracted.

**3.8-10 Generator (If Equipped)****To start generator:**

1. On platform control console, select lift/drive switch to  lift position.
2. On outrigger/generator control console, select generator switch to “|” energized position. The engine will automatically switch to low throttle and the generator will start.

**To restore normal operation:**

3. Flip generator switch to “○” off position. The generator will turn off.

**NOTE**

Activating any lift or outrigger functions, changing key switch settings, activating emergency stop or an engine stall will turn off the generator. The platform may be lowered during generator operation.

**3.8-11 Electrical Inverter (If Equipped)**

The inverter is operational with alternating current available at all times when the aerial platform is on. The emergency stop button will turn the inverter off.

**To check status of inverter:**

1. Inverter state is indicated by the LEDs on the face of the inverter. A glowing green LED indicates normal operation. If a fault occurs, the status LEDs will indicate the area responsible. Refer to [Section 3.6-2](#).

**3.8-12 Shutdown Procedure**

1. Completely lower the platform.
2. On the platform control console, push in  emergency stop button.

**WARNING**

**Ensure that you maintain three points of contact when using the ladder to mount/dismount platform.**

3. Use the ladder to dismount from platform..
4. Turn platform/engine/base key switch to “” engine position and remove key.
5. Turn emergency main power disconnect switch to “○” off position.

### 3.9 Refueling Procedure

This section provides the operator with the procedure on how to refuel the engine with regular fuel and install the propane cylinder.

#### **IMPORTANT**

**Before using the aerial platform ensure there is enough fuel to finish the job.**



#### **WARNING**

**Follow all local and national regulations for propane handling.**

- **Use extreme caution while refueling aerial platforms.**
- **Ensure engine and all systems are turned off before refueling.**
- **Refuel aerial platform only in a well ventilated area away from open flame and other sources of ignition, authorized by your employer and supervisor.**
- **Liquid propane gas fuel is a gas that is heavier than air. It settles in low spots. Any flame or spark could cause a fire that could cause serious injury.**
- **When changing liquid propane gas cylinder, check all connections for damage or missing parts. Never try to start an aerial platform if you smell gas.**
- **For gasoline engine models, use only unleaded gasoline with an octane rating 87 or higher.**



#### **WARNING**

**Do not smoke in an area where aerial platforms are stored or refueled.**

### 3.9-1 Regular Fuel

1. Ensure engine and all systems are turned off and emergency stop buttons are depressed.
2. Open fuel compartment door and remove fuel cap.
3. Carefully pour fuel into tank ensuring that no spillage occurs.
4. Securely replace fuel cap.
5. Ensure there are no leaks in the fuel system.
6. Wipe up any spilled fuel.
7. Dispose of rags in an approved container.

### Protection of Environment from Chemical Dangers



#### **WARNING**

**Gasoline, diesel fuel, engine oil and hydraulic fluid are chemicals, which can contaminate the environment. If they are spilled during filling and reach the water, they can cause damage to the environment, e.g., death of fish. For such damage, the party responsible is liable! Therefore, gasoline, diesel fuel, engine oil or hydraulic fluid must not get into the sewage system, streams, rivers or other surface water. For that reason, immediately remove the dripped off or spilled gasoline, diesel fuel, engine oil or hydraulic fluid with appropriate means and dispose of these means according to the regulations.**

**3.9-2 Propane****WARNING**

**Follow all local and federal regulations for propane handling.**

**To remove a propane cylinder:**

1. Ensure engine and all systems are turned off and emergency stop button is depressed.
2. Turn propane cylinder's main valve clockwise to shut off fuel supply to engine.
3. Start engine and allow it to stop naturally. Restart engine to ensure fuel lines are empty.
4. Disconnect hose from empty propane cylinder by detaching the coupling. Turn fitting counterclockwise.
5. Loosen two propane cylinder straps by pulling up on the metal clips. Disconnect straps from hooks.
6. Remove the propane cylinder.

**To install a propane cylinder:**

1. Ensure engine and all systems are turned off and emergency stop button is depressed.
2. Place propane cylinder on bracket or in compartment.
3. Ensure metal peg on bracket or compartment is inserted into propane cylinder rim.
4. Reconnect propane cylinder straps to hooks and fasten tightly.
5. Attach coupler to propane cylinder and turn clockwise to tighten fitting.
6. Apply soap water or neutral detergent to pipe connection and cylinder.
7. Open valve 1/4 turn counterclockwise and check for any gas leaks.
8. Wipe off soap water or detergent after inspection is completed.
9. Open main valve fully if there are no leaks.

**NOTE**

The aerial platform is now ready for use by an authorized, qualified operator who has read and completely understands all of [Section 3](#) operations in this manual.

### 3.10 Guardrail Folding Procedure

When folded down, the folding guardrail system reduces the height of the retracted aerial platform for transporting only.



#### WARNING

**Any lowered guardrail will create a fall hazard. Remain away from the sides of the platform while raising or lowering the guardrails to avoid falling.**

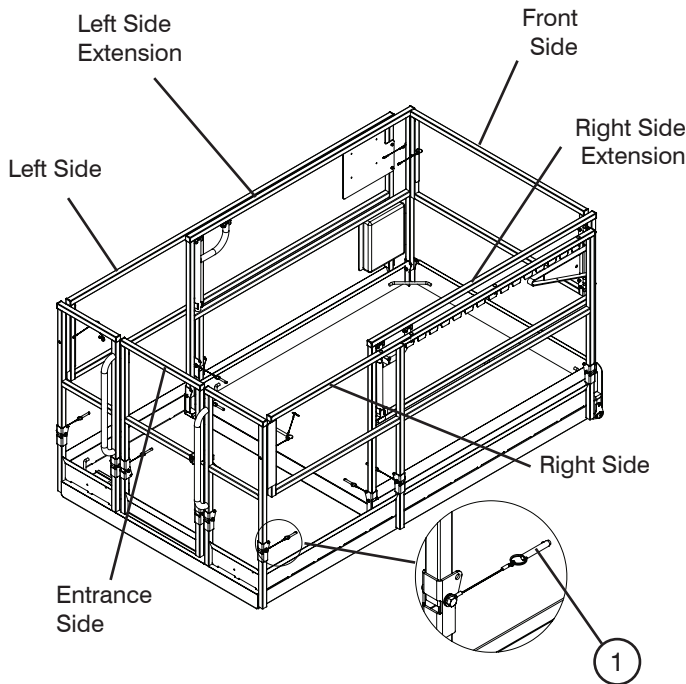

Figure 3-8a. Folding Guardrail System

1. **Guardrail Locking Pin with Lanyard** - This pin is used to lock the guardrail in place.



#### WARNING

**The scissor assembly must be fully lowered before raising or lowering the guardrails.**



#### WARNING

**Before operating this aerial platform check the guardrail system for loose or missing locking pins. The guardrail system must be upright and all pins must be locked in place. Death or serious injury could result if the guardrail system is not upright or properly locked.**

To fold the guardrail system down:

1. Ensure aerial platform is on level ground.
2. Ensure extension platform is fully retracted.
3. Ensure Emergency Stop button is depressed.
4. Turn emergency main power disconnect switch to "○" off position.



#### WARNING

**Ensure that you maintain three points of contact when using the ladder to mount/dismount platform.**

5. Use the ladder of aerial platform to access platform.
6. Close the gate.
7. Retract the extension platform fully. Refer to [Section 3.8-8](#).
8. Remove the platform control console and outrigger controls (if equipped) and lay it down on the platform.



#### WARNING

**Any lowered guardrail will create a fall hazard. Use caution when exiting or entering the platform when the guardrails are lowered.**

9. Fold down guardrails in the following order: front, right extension, left extension, right-side, left-side and entrance (refer to [Figure 3-8a](#)).
10. Remove the locking pin that secured the **front guardrail** to the left extension guardrail then swing it towards the right extension and tie wrap front gate to right side guardrail.
11. Remove the locking pin on the **right side extension** guardrail and fold it down with the front guardrail.
12. Remove the locking pin on the **left side extension** guardrail and fold it down.
13. Remove the locking pins on the **right side** guardrail and fold it down.



14. Remove all the locking pins on the **left side** guardrail and fold it down.
15. With the gate closed, remove all the locking pins on the **entrance side** guardrail and fold the guardrail down.

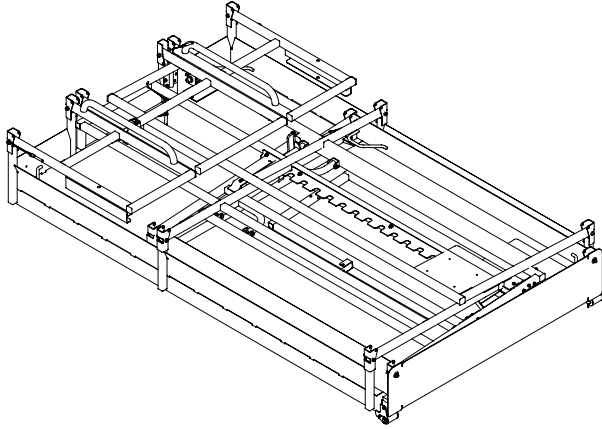

Figure 3-8b. All Guardrails Folded Down

To raise the guardrail system up:



**WARNING**

The scissor assembly must be fully lowered before raising or lowering the guardrails.

1. Ensure that the aerial platform is on level ground.
2. Ensure extension platform is fully retracted.
3. Ensure Emergency Stop button is depressed.
4. Turn emergency main power disconnect switch to “○” off position.



**WARNING**

Any lowered guardrail will create a fall hazard. Use caution when exiting or entering the platform when the guardrails are lowered.



**WARNING**

Ensure that you maintain three points of contact when using the ladder to mount/dismount platform.

5. Use the ladder of aerial platform to access platform.



**WARNING**

Any lowered guardrail will create a fall hazard. Remain away from the sides of the platform while raising or lowering the guardrails to avoid falling.



**WARNING**

Ensure that the detent ball of each locking pin is all the way through and each cotter pin fully inserted into the pin hole.

6. Raising the guardrails up is done in the following order: entrance side, left side, right side, left side extension, right side extension and front side.
7. Swing up the **entrance side** guardrail then lock it in place by inserting all locking pins.
8. Swing up the **left side** guardrail and lock it in place by inserting all locking pins.
9. Swing up the **right side** guardrail and lock it in place by inserting all locking pins.
10. Swing up the **left side extension** guardrail and lock it in place by inserting the locking pin.
11. Swing up the **right side extension** guardrail and the front guardrail and lock them in place by inserting the locking pin on the right extension.
12. Swing the **front side** guardrail forward and lock it in place by inserting the locking pin.
13. Mount the platform control console and outrigger controls (if equipped) at the front right of the platform. Lock them in place.



**WARNING**

Before operating this aerial platform check the guardrail system for loose or missing locking pins. The guardrail system must be upright and all pins must be locked in place. Death or serious injury could result if the guardrail system is not upright or properly locked.

### 3.11 Loading/Unloading

Know all national, state or territorial/provincial and local rules which apply to your loading/unloading of aerial platforms.

Only qualified personnel shall operate machinery during loading/unloading.

Be sure vehicle capacity and loading equipment hoists, chains, straps, etc., are sufficient to withstand maximum aerial platform weight.

The transport vehicle must be parked on a level surface and must be secured to prevent rolling while aerial platform is being loaded/unloaded.

#### 3.11-1 Lifting

When it is necessary to lift the Skyjack aerial platform the following conditions must be met:

- The platform must be fully lowered.
- The emergency main power disconnect switch must be in “○” off position.
- The hydraulic/fuel and engine compartments must be closed and securely latched.
- The extension platform must be retracted and secured.
- The platform control console must be secured to the railings or removed.
- The platform must be cleared of all personnel, tools and materials.
- The lifting/rigging must be attached to all twelve lifting points as illustrated in [Figure 3-9](#).

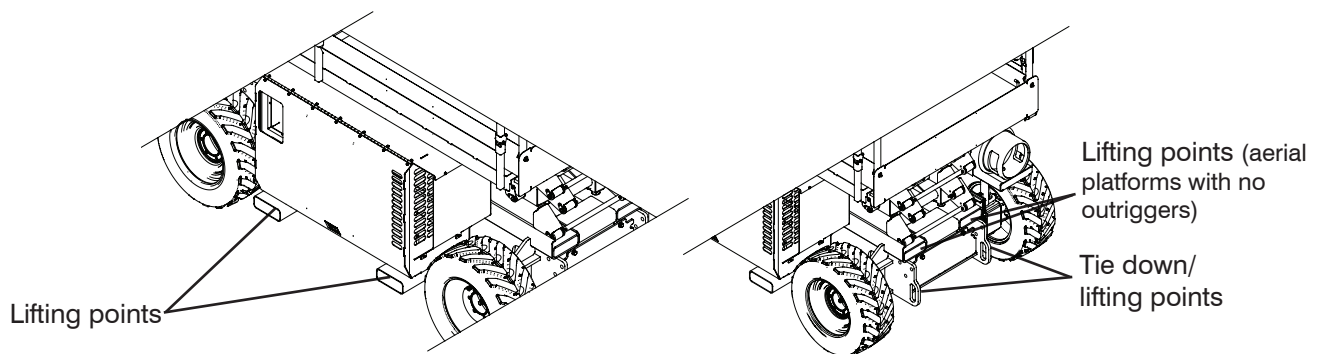

Figure 3-9. Tie Downs/Lifting Points

**NOTE**

The mass of the aerial platform is as per [Table 4.2](#). The center of gravity is approximately located in the middle of the aerial platform, front to back and side to side, as illustrated in [Figure 3-10](#). Vertically, the center of gravity is approximately just above the base chassis.

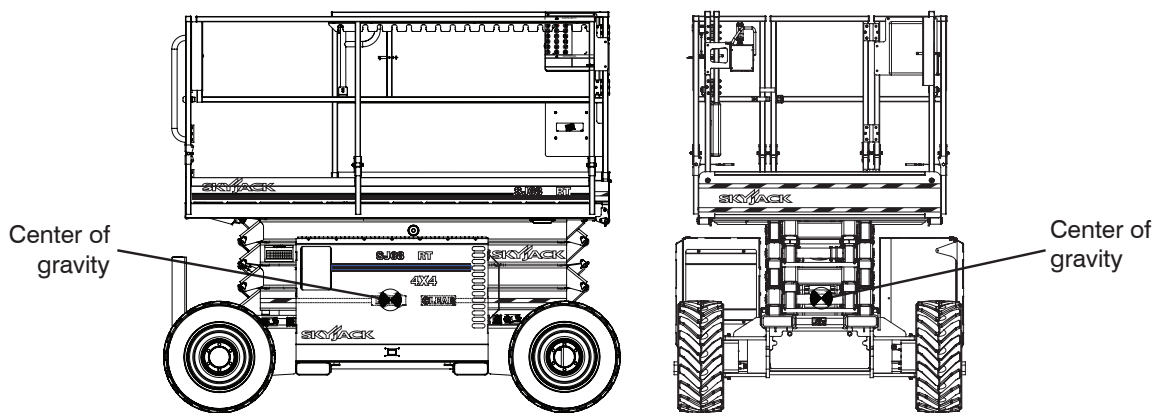

Figure 3-10. Center of Gravity

**NOTE**

The aerial platform can be lifted with a forklift from the sides but Skyjack does not recommend this use. Lift with forks in designated pockets as illustrated in [Figure 3-11](#).

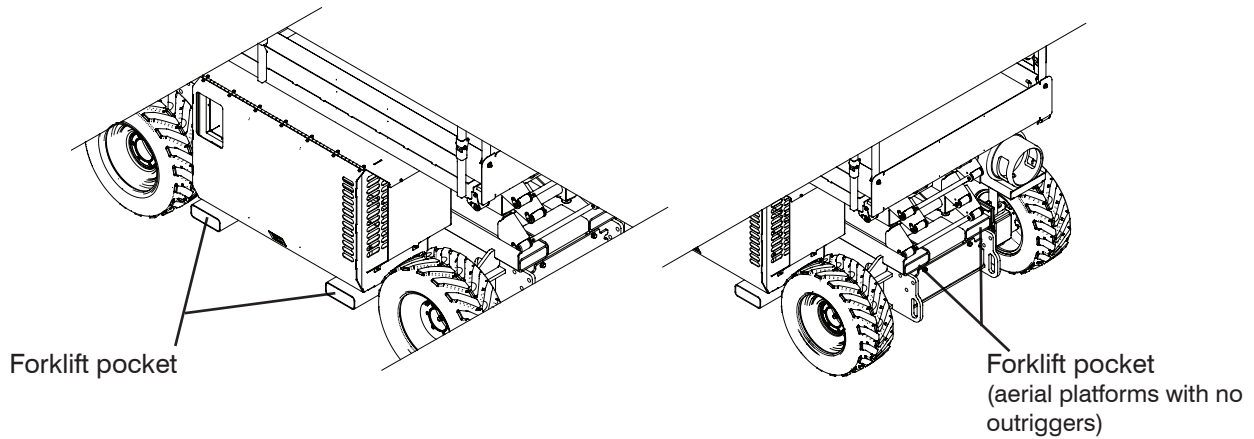

Figure 3-11. Forklift Pockets

**3.11-2 Driving**

When driving the aerial platform:

- Ramp or dock capacity should be sufficient to withstand maximum aerial platform weight.
- Ramp should be equipped with side guards to prevent inadvertent fall from the ramp.
- Incline should not exceed aerial platform gradeability (refer to [Table 4.2](#)).
- Aerial platform brakes should be checked for proper operation.
- Aerial platform speed should be on high torque setting.

**WARNING**

**When transporting, the aerial platform must be secured to the truck or trailer deck. Tie downs are available as illustrated in [Figure 3-9](#).**

### 3.12 Moving the Aerial Platform Through a Doorway



#### WARNING

**This procedure is suitable for level ground only.**

1. Confirm that the height/width of the doorway is sufficient to allow the aerial platform to pass through.

#### NOTE

If it is necessary to fold the guardrails, refer to [Section 3.10](#) for guardrail folding procedure.

2. Perform a thorough jobsite inspection prior to operating the aerial platform to identify potential hazards in your work area.
3. Cordon-off the pathway which you intend to travel.
4. Position the aerial platform to allow all future motion, including through the doorway, to be in a forward direction.
5. Turn emergency main power disconnect switch to “○” off position.
6. Use the ladder of aerial platform to access platform.



#### WARNING

**Ensure that you maintain three points of contact when using the ladder to mount/dismount platform.**

7. Close the gate. On platform control console, push in “●” emergency stop button.
8. Disconnect and remove platform control console from the platform.
9. Fold the guardrails if necessary. (Refer to [Section 3.10](#) for guardrail folding procedure.)
10. Use the ladder to dismount from platform.
11. Connect platform control console to the connection inside the engine cabinet.

12. Ensure there are no personnel in the intended path of travel.
13. Notify those around the pathway that you will be moving the aerial platform.
14. Use a spotter to guide movement. Ensure the spotter remains at a safe distance.
15. Ensure that the platform control console is properly oriented in the direction the aerial platform is facing.
16. Turn emergency main power disconnect switch to “|” on position.
17. On base control console, pull out “●” emergency stop button.
18. Insert key into platform/engine/base key switch and turn it to “🔑” platform position.
19. On platform control console, pull out “●” emergency stop button.
20. Turn low/high throttle switch to “🔧” low throttle position.



#### CAUTION

**Do not start the engine in the high throttle position.**

21. Start engine.



#### DANGER

**Do not drive the aerial platform toward yourself.**

22. On platform control console, select torque switch to “🔧” low speed drive position.
23. Using as low a speed as practical and the operator positioned behind the aerial platform, drive forward through doorway.
24. Once safely through doorway, push in “●” emergency stop button and turn emergency main power disconnect switch to “○” off position.

25. Disconnect platform control console and return it to the platform.

**WARNING**

**Ensure that you maintain three points of contact when using the ladder to mount/dismount platform.**

26. Return guardrails to upright position if folded. (Refer to [Section 3.10](#) for guardrail folding procedure.)

**WARNING**

**Before operating this aerial platform check the guardrail system for loose or missing locking pins. The guardrail system must be upright and all pins must be locked in place.**

**Death or serious injury could result if the guardrail system is not upright or properly locked.**

27. Once platform control console is securely reconnected and guardrails up, normal operation may continue.

### 3.13 Maintenance Support Procedure

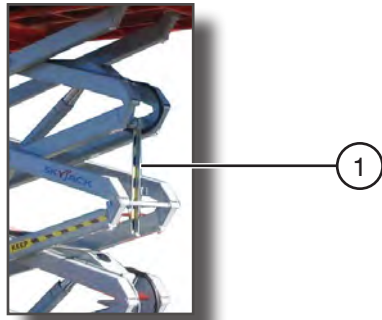

Figure 3-12. Maintenance Support

1. **Maintenance Support** - The maintenance support is a safety mechanism designed to support the scissor assembly. When properly positioned it can support the scissor assembly and empty platform. The maintenance support must be used when inspection and/or maintenance is to be performed within the lifting mechanism.



#### **WARNING**

**The maintenance support must be used when inspection and/or maintenance or repairs are to be performed within the lifting mechanism. Failure to use this safety mechanism could result in death or serious injury.**

#### To Deploy the Maintenance Support

1. Remove all material from platform.
2. Raise platform until there is adequate clearance to swing down maintenance support.
3. Swing maintenance support down from storage bracket into a vertical position.
4. Remove hands and arms from scissors area.
5. Lower platform until bottom end of maintenance support contacts the labeled cross bar and scissors are supported by maintenance support.
6. Turn emergency main power disconnect switch to "○" off position.

#### To Store the Maintenance Support

1. Turn emergency main power disconnect switch to "I" on position.
2. Raise platform until there is adequate clearance to swing up the maintenance support.
3. Swing bar up into storage bracket.
4. Lower the platform.



#### **WARNING**

**Do not reach through the scissor assembly when the platform is raised without the maintenance support properly positioned. Failure to avoid this hazard could result in death or serious injury.**

Table 4.1 Standard and Optional Features

MODEL	Compact RT's	
	6826	6832
<b>STANDARD EQUIPMENT</b>		
Platform controls	*	*
Base controls	*	*
Four-wheel drive	*	*
23.1 kW (31 hp) Kubota DF972 dual fuel - gasoline/propane engine	*	*
Easy operation 60" roll out extension	*	*
Swing out engine tray	*	*
Multiple wet disc – Spring applied hydraulic release brakes	*	*
Manual brake release	*	*
110V AC outlet on platform	*	*
Tilt alarm with drive/lift cutout	*	*
Lanyard attachment points	*	*
Hinged railing system	*	*
Operator horn	*	*
Spring loaded full height gate at rear	*	*
Forklift pockets, tie down/lifting lugs	*	*
Foam filled low profile grip lug tires	*	*
Hourmeter	*	*
Color coded and numbered wiring system	*	*
Hydraulic oil level indicators	*	*
<b>OPTIONAL EQUIPMENT</b>		
Flashing light	*	*
18.5 kW (24.8 hp) Kubota D902 diesel water-cooled engine	*	*
Diesel scrubber	*	*
All motion audible alarm	*	*
Shop air line to platform	*	*
800 Watt AC inverter	*	*
Work lights	*	*
Independent leveling hydraulic outriggers	*	*
Extra propane tank	*	*

60436AE-ANSI

4

**Table 4.2 Specifications and Features**





Model		Compact RT's			
		6826		6832	
Weight*	No Outriggers	6400 lb.	2903 kg	7660 lb.	3475 kg
	With Outriggers	7500 lb.	3402 kg	8060 lb.	3656 kg
Width		68"	1.73 m	68"	1.73 m
Length	No Outriggers	106.6"	2.71 m	106.6"	2.71 m
	With Outriggers	131.4"	3.34 m	131.4"	3.34 m
Platform Size		56" x 99"	1.4 m x 2.5 m	56" x 99"	1.4 m x 2.5 m
Height	Working	32 ft.	9.8 m	38 ft.	11.7 m
	Platform Elevated	26 ft.	8 m	32 ft.	9.8 m
	Platform Lowered	7.8 ft.	2.37 m	8.25 ft.	2.52 m
	Drive	26 ft.	7.95 m	32 ft.	9.8 m
Speed	Normal Drive	4 mph	6.3 km/h	4 mph	6.3 km/h
	Elevated Drive	0.39 mph	0.63 km/h	0.39 mph	0.63 km/h
	Lift (Rated Load)	36 sec		39 sec	
	Lower (Rated Load)	36 sec		36 sec	
Engine (RPM)	Kubota Diesel	3500 (High Throttle) / 2050 (Low Throttle)			
	Kubota Dual Fuel	3500 (High Throttle) / 2050 (Low Throttle)			
Tires	Foam-filled	OTR Outrigger - 26 x 12			
	Air-filled	OTR Outrigger 40PSI		N/A	
Sound Pressure		96 dB(A)			
Gradeability (Torque Equivalent To)		50%		40%	

RTC T4.2AB - 133048AP

\* Weights are approximate; refer to serial nameplate for specific weight.





**Table 4.3 Owner's Annual Inspection Record**

										
	Model Number: _____ Serial Number: _____									
*		20__	20__	20__	20__	20__	20__	20__	20__	20__
**										

1000AB

This decal is located on the scissor assembly. It must be completed after an annual inspection has been completed. Do not use the aerial platform if an inspection has not been recorded in the last 13 months.

	Pictorial	Description
*		Inspection Date
**		Inspector Signature

**Table 4.4 Maximum Platform Capacities (Evenly Distributed)**

MODEL		Total Machine Weight			Extension			Maximum Wind Speed	Tilt Cutout Setting (Degrees)
		Capacity		Number of Occupants	Capacity		Number of Occupants		
<b>6826</b>	One Extension Platform	1250 lb.	567 kg	4	300 lb.	136 kg	1	12.5 m/s	2.5 x 4.5
<b>6832</b>	One Extension Platform	1000 lb.	453.6 kg	4	300 lb.	136 kg	1	12.5 m/s	2.5 x 4.5

RTC T4.4AB - 133048AP

**NOTE:**

Occupants and materials are not to exceed rated load.  
 Refer to capacity label for additional information and for models equipped with options.

Table 4.5 Floor Loading Pressure

MODEL		Total Aerial Platform Weight		Total Aerial Platform Load					
				Wheel		LCP**		OUP**	
		lb.	kg	lb.	kg	psi	kPa	psf	kg/m <sup>2</sup>
6826	min*	6400	2903	2560	1161	152	1046	206	1007
	max*	8666	3931	3466	1572	168	1159	280	1364
6826 Outrigger Pads	min*	7286	3305	2914	1322	37	256	235	1146
	max*	8666	3931	3466	1572	44	305	280	1364
6832	min*	7661	3475	3064	1390	162	1114	247	1205
	max*	9189	4168	3675	1667	171	1179	296	1446
6832 Outrigger Pads	min*	8058	3655	3223	1462	41	283	260	1268
	max*	9189	4168	3675	1667	47	323	296	1446

1014AA-ANSI

\* **min** - Total aerial platform weight with no options

**max** - aerial platform weight + all options + full capacity

\*\* **LCP – Locally Concentrated Pressure** is a measure of how hard the aerial platform presses on the areas in direct contact with the floor. The floor covering (tile, carpet, etc.) must be able to withstand more than the indicated values above.

**OUP – Overall Uniform Pressure** is a measure of the average load the aerial platform imparts on the whole surface directly underneath it. The structure of the operating surface (beams, etc.) must be able to withstand more than the indicated values

**NOTE:**

The **LCP** or **OUP** that an individual surface can withstand varies from structure to structure and is generally determined by the engineer or architect for that particular structure.

**Floor Loading Pressure**

**Locally Concentrated Pressure (LCP):**

$$\text{Foot Print Area} = \text{Length} \times \text{Width} \\ = \pi r^2$$

$$\text{LCP} = \frac{\text{Weight of Aerial Platform} + \text{Capacity}}{\text{Foot Print Area} \times 4 \text{ (Tires)}}$$

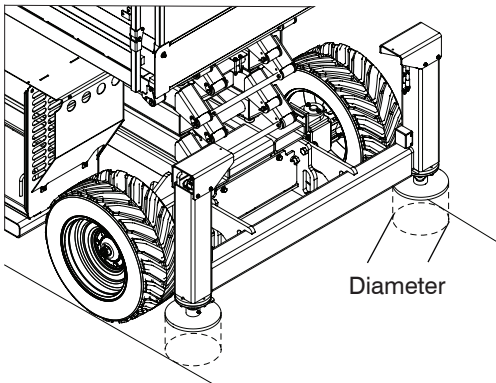
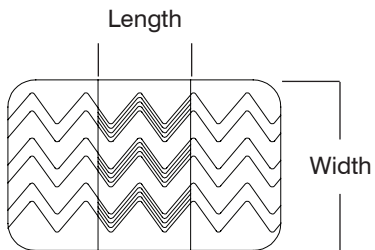
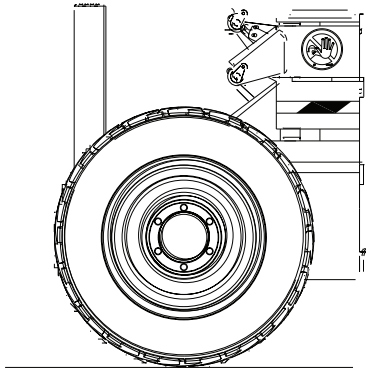

**Overall Uniform Pressure (OUP):**

$$\text{Base Area} = \text{Length} \times \text{Width}$$

$$\text{OUP} = \frac{\text{Weight of Aerial Platform} + \text{Capacity}}{\text{Base Area}}$$

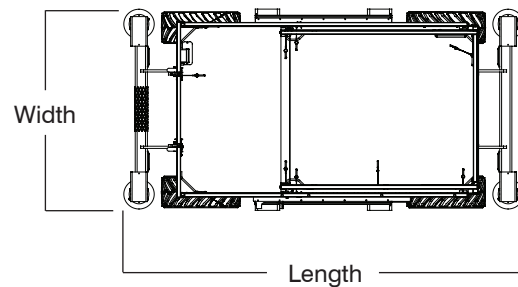
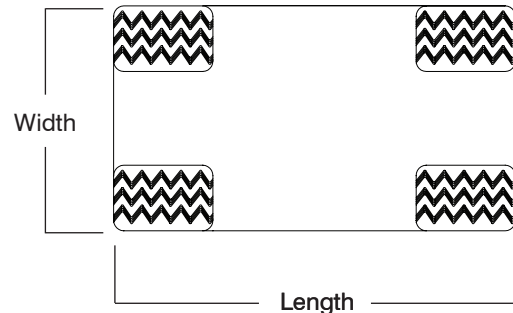
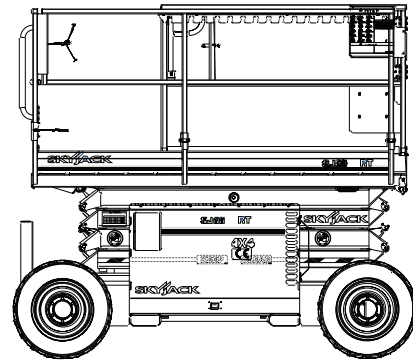

**! WARNING**

**Intermixing tires of different types or using tires of types other than those originally supplied with this equipment can adversely affect stability. Therefore, replace tires only with the exact Skyjack-approved type. Failure to operate with matched approved tires in good condition may result in death or serious injury.**

### General Maintenance

Before attempting any repair work, disconnect battery by turning emergency main power disconnect switch to “○” off position. Preventive maintenance is the easiest and least expensive type of maintenance.

**Table 4.6 Maintenance and Inspection Schedule**

Frequency	Daily	3 months or 150 hours	Yearly	Frequency	Daily	3 months or 150 hours	Yearly
<b>Visual and Daily Maintenance Inspections</b>				Maintenance Support	A		
Labels	A			Scissor Assembly	A		
Electrical	A			Scissor Bumpers	A		
Limit Switches	A			Rollers	A		
Hydraulic	A			Lift Cylinder(s)	A		
<b>Engine Compartment</b>				<b>Base</b>			
Main Power Disconnect Switch	A			Base Weldment	A		
Base Control Switches	A			Wheel/Tire Assembly	A		
Tilt Sensor	A			Steer Cylinder Assembly	A		
Battery	A			Splitter Manifold	A		
Hydraulic Pump	A			Tie Rod	A		
Radiator	A			Emergency Lowering Access Rod	A		
Muffler and Exhaust	A			Ladder	A		
Engine Pivot Tray	A			Outriggers (If Equipped)	A		
Engine Oil Level	A			<b>Function Tests</b>			
Fuel Shut-off Valve	A			<b>Test Main Power Disconnect Switch</b>	A		
Engine Air Filter	A			<b>Base Control Console</b>			
Fuel Leaks	A			Test Platform/Engine/Base Key Switch	A		
<b>Hydraulic/Fuel Compartment</b>				Test Emergency Stop	A		
Hydraulic Tank	A			Test Platform Raise/Lower Switch	A		
Hydraulic Oil	A			Test Emergency Lowering	A		
Hydraulic Return Filter	A			Test Free-wheeling	A		
Fuel Tank	A			<b>Platform Control Console</b>			
Fuel Leaks	A			Test Emergency Stop	A		
Main Manifold	A			Test Enable Trigger Switch	A		
Gear Type Flow Divider	A			Test Platform Raising/Lowering	A		
<b>Platform Assembly</b>	A			Test Steering	A		
Lanyard Attachment Anchors	A			Test Driving	A		
AC Outlet on Platform	A			Test Speed Limit	A		
Manuals	A			Test Brakes	A		
Platform Control Console	A			Test Horn	A		
<b>Lifting Mechanism</b>				Test Outriggers (If Equipped)	A		

B\*†

B\*†

B\*†

60601AD-ANSI

A - Perform Visual and Daily Maintenance Inspections & Functions Test. Refer to Section 2.3 and Section 2.4 of this manual.

B - Perform Scheduled Maintenance Inspection. Refer to Service & Maintenance manual.

\* - Maintenance must be performed only by trained and competent personnel who are familiar with mechanical procedures.

† - Refer to Skyjack's website @ [www.skyjack.com](http://www.skyjack.com) for latest service bulletins prior to performing quarterly or yearly inspection.



**WARNING**

**Use original or manufacturer-approved parts and components for aerial platform.**

**Table 4.7 Operator's Checklist**



Serial Number: \_\_\_\_\_  
 Model: \_\_\_\_\_  
 Hourmeter Reading: \_\_\_\_\_  
 Date: \_\_\_\_\_  
 Time: \_\_\_\_\_

Operator's Name (Printed): \_\_\_\_\_  
 Operator's Signature: \_\_\_\_\_

Each item shall be inspected using the appropriate section of the Skyjack operating manual.  
 As each item is inspected, check the appropriate box.

- P** - PASS
- F** - FAIL
- R** - REPAIRED
- NA** - NOT APPLICABLE
- DAILY
- FREQUENTLY
- ANNUALLY
- BI-ANNUALLY

	N/A	P	F	R
<b>Visual and Daily Maintenance Inspections</b>				
<b>Labels</b>				
<b>Electrical</b>				
<b>Limit Switches</b>				
<b>Hydraulic</b>				
<b>Entrance Side</b>				
Emergency Main Power Disconnect Switch				
Base Control Switches				
Tilt Sensor				
Battery				
Hydraulic Pump				
Radiator				
Muffler and Exhaust				
Engine Pivot Tray				
Engine Oil Level				
Fuel Shut-off Valve				
Engine Air Filter				
Fuel Leaks				
<b>Hydraulic/Fuel Compartment</b>				
Hydraulic Tank				
Hydraulic Oil				
Hydraulic Return Filter				
Fuel Tank				
Fuel Leaks				
Main Manifold				
Gear Type Flow Divider				
<b>Platform Assembly</b>				
Lanyard Attachment Anchors				
AC Outlet on Platform				
Manuals				
Platform Control Console				
<b>Lifting Mechanism</b>				

	N/A	P	F	R
Maintenance Support				
Scissor Assembly				
Scissor Bumpers				
Rollers				
Lift Cylinder(s)				
<b>Base</b>				
Base Weldment				
Wheel/Tire Assembly				
Steer Cylinder Assembly				
Splitter Manifold				
Tie Rod				
Emergency Lowering Access Rod				
Ladder				
Outriggers (If Equipped)				
<b>Function Tests</b>				
<b>Test Emergency Main Power Disconnect Switch</b>				
<b>Base Control Console</b>				
Test Platform/Engine/Base Key Switch				
Test Emergency Stop				
Test Platform Raise/Lower Switch				
Test Emergency Lowering				
Test Free-wheeling				
<b>Platform Control Console</b>				
Test Emergency Stop				
Test Enable Trigger Switch				
Test Platform Raising/Lowering				
Test Steering				
Test Driving				
Test Speed Limit				
Test Brakes				
Test Horn				
Test Outriggers (If Equipped)				

**Note:**  
 Make a copy of this page or visit the Skyjack web site:  
[www.skyjack.com](http://www.skyjack.com) for a printable copy.

60602AD-ANSI

Label Legend



Safety Red indicates DANGER.

Safety Red



Safety Orange indicates WARNING.

Safety Orange

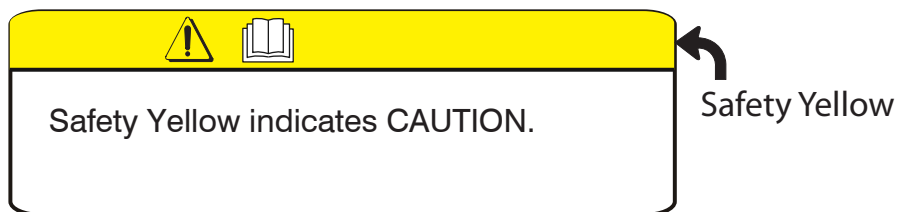

Safety Yellow indicates CAUTION.

Safety Yellow

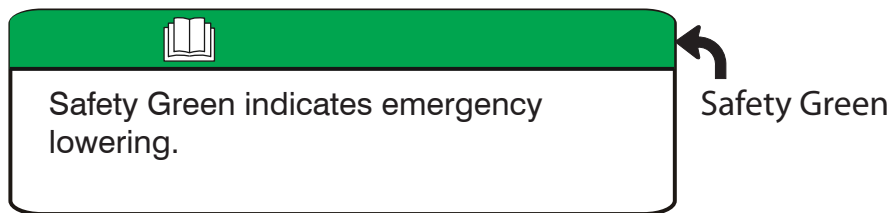

Safety Green indicates emergency lowering.

Safety Green

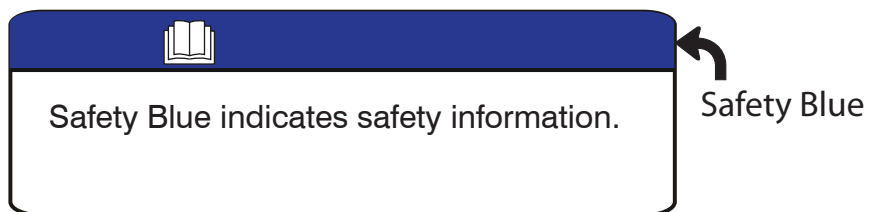

Safety Blue indicates safety information.

Safety Blue

Labels - Models 6826 & 6832

Engine Panel

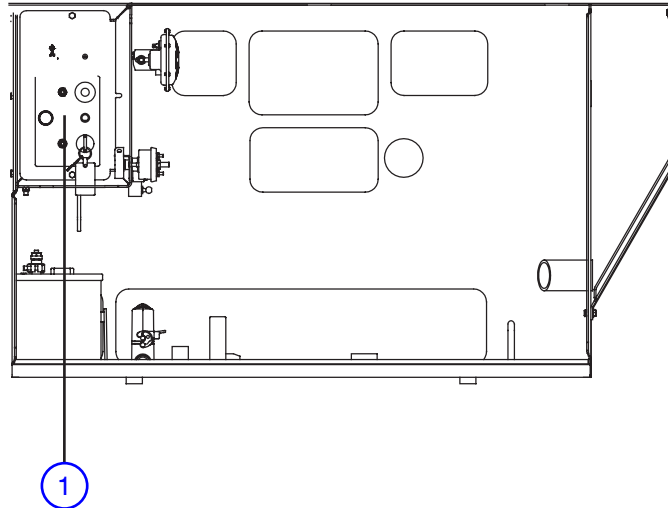

No.	Label Pictorial	Description
1		<p><b>Electrical Panel</b></p> <p>Push “” to reset ground circuit breaker.</p> <p>Push “” to reset power circuit breaker.</p> <p>Push “” to stop engine and disable controls (Emergency Stop).</p> <p>Light indicates controls enabled.</p> <p>Push and hold “” to start engine.</p> <p>Push and hold “” to operate choke (dual fuel) or “” glow plugs (diesel).</p> <p>Select “” gasoline or “” propane. Light “” indicates glow plug operation (diesel).</p> <p>Select “” to raise or “” to lower platform.</p> <p>Select “” to enable platform controls, “” to allow engine run with no controls active or “” to enable base control console.</p> <p>Read operating manual. </p>



Labels - Models 6826 & 6832



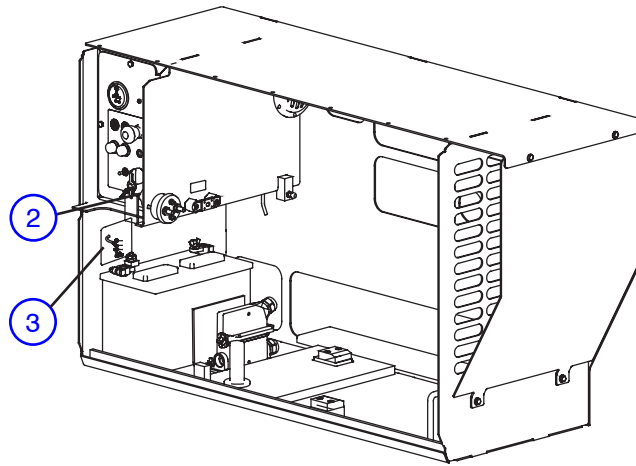

Engine Panel (Continued)

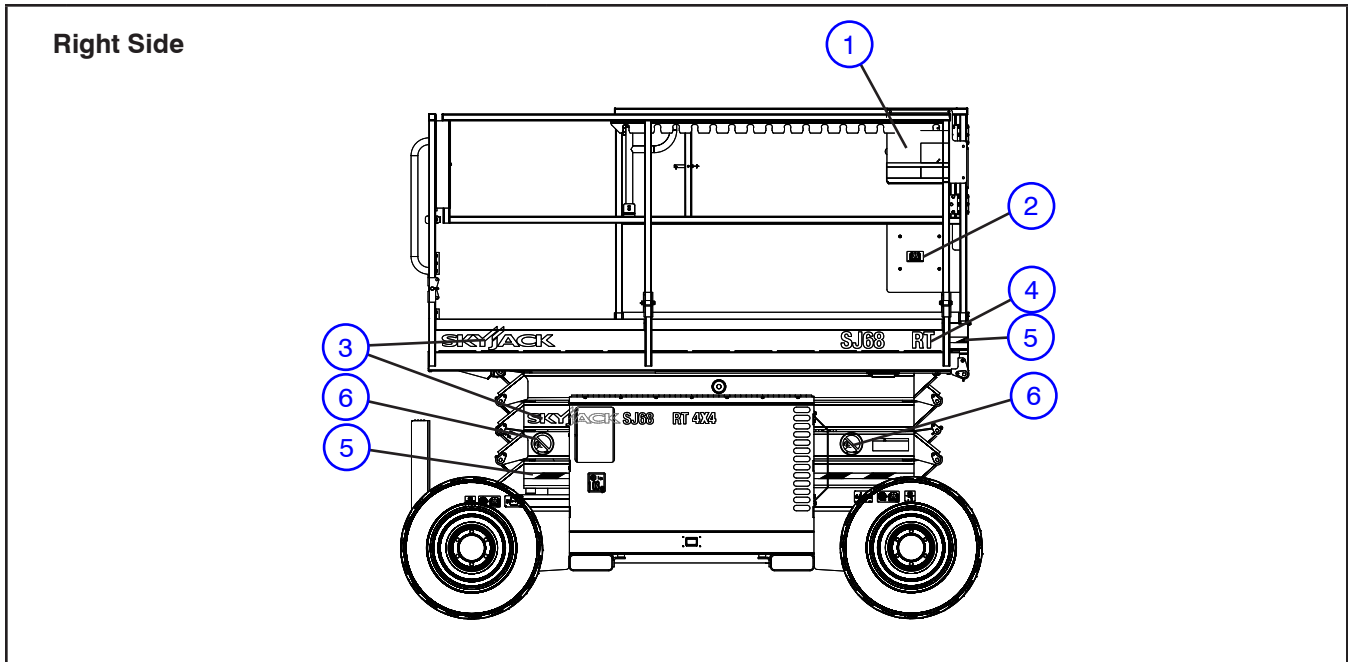

No.	Label Pictorial	Description
2		<p><b>Main Power Disconnect</b> Main power disconnect switch</p>
3		<p><b>Battery Fuse Assembly</b> Assemble fuse as shown. Torque to value indicated.</p>

Labels - Models 6826 & 6832

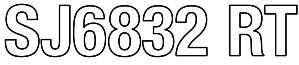

No.	Label Pictorial	Description
1		<p><b>Hazard Identification</b></p> <p>Refer to <a href="#">Section 1: Safety Rules</a>. Read and understand the outlined risks associated with this work platform prior to operation.</p>
2		<p><b>Manual Storage Box</b></p> <p>Indicates location of operating manual.</p>
3		<p><b>Skyjack Logo</b></p> <p>Skyjack</p>
4		<p><b>Model Number*</b></p> <p>Product Identifier *Model number will vary, may not be as shown.</p>
5		<p><b>Caution Tape Stripe</b></p> <p>Caution stripe</p>
6		<p><b>Keep Clear</b></p> <p>Keep clear. Stay away from aerial platform when in operation.</p>

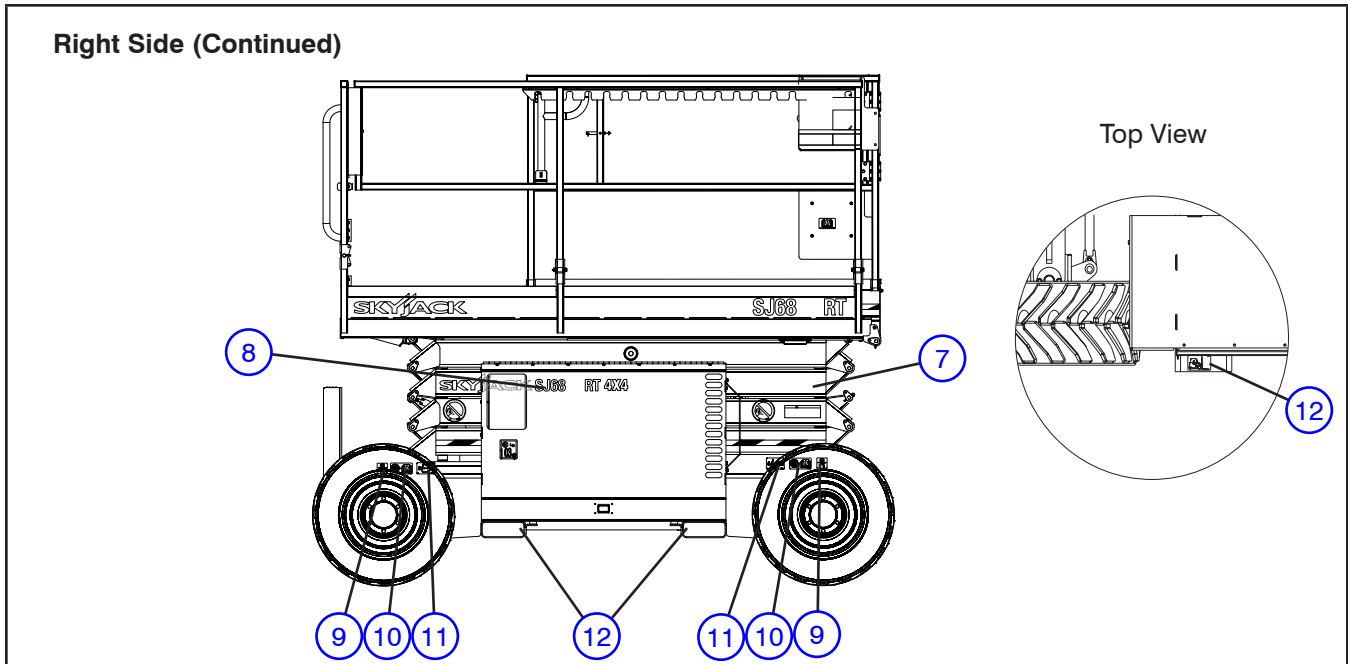

Labels - Models 6826 & 6832

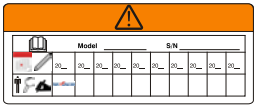
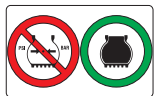
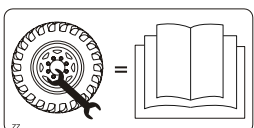
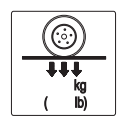
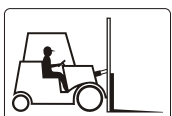

No.	Label Pictorial	Description
7		<p><b>Annual Inspection</b></p> <p>Ensure that work platform has received annual inspection prior to operation.</p>
8	<p>SJ6832 RT 4X4</p>	<p><b>Model Number*</b></p> <p>Product Identifier *Model number will vary, may not be as shown.</p>
9		<p><b>Foam-filled Tire</b></p> <p>Indicates foam-filled tire only.</p>
10		<p><b>Wheel Specifications</b></p> <p>Refer to manual for wheel type, offset, pressure and torque.</p>
11		<p><b>Wheel Load</b></p> <p>Indicates rated wheel load.</p>
12		<p><b>Forklift Pocket</b></p> <p>Insert fork fully into pocket to lift aerial platform.</p>

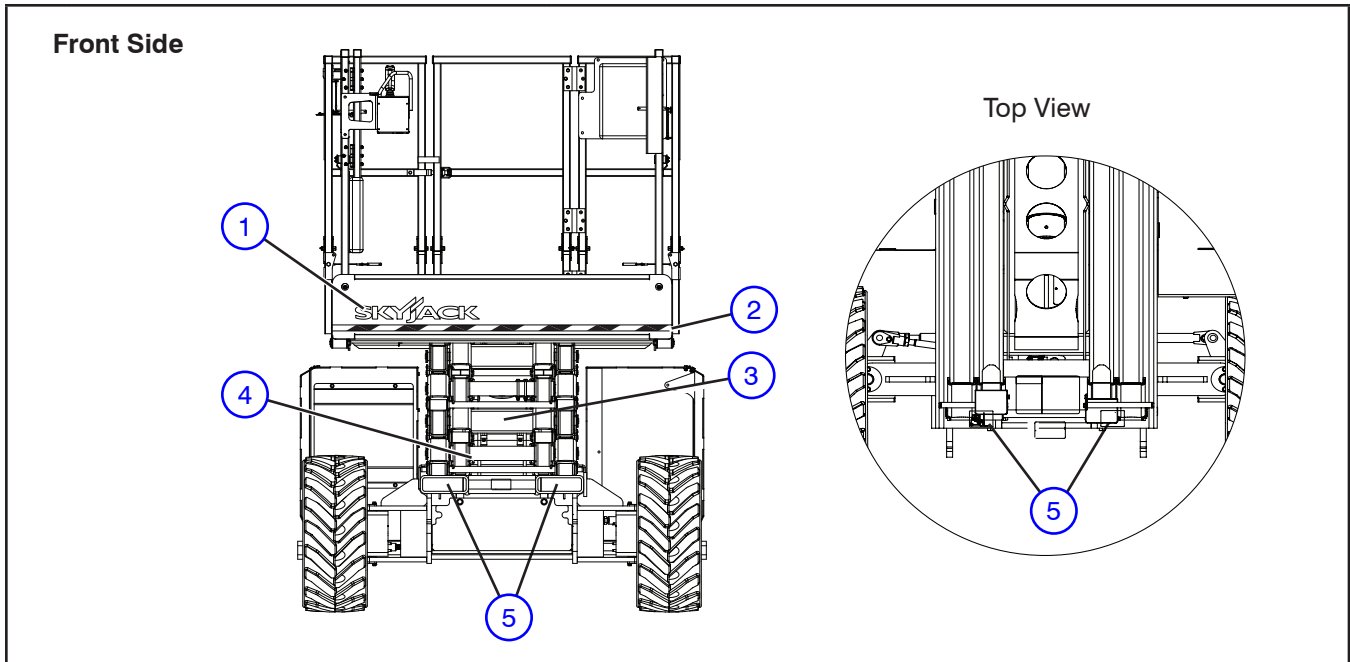
Labels - Models 6826 & 6832

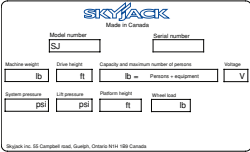
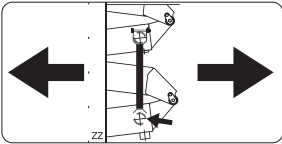
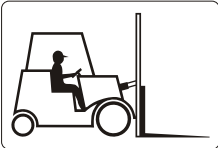

No.	Label Pictorial	Description
1		<p><b>Skyjack Logo</b> Skyjack</p>
2		<p><b>Caution Tape Stripe</b> Caution stripe</p>
3		<p><b>Serial Plate</b> Product identification and specifications</p>
4		<p><b>Maintenance Support</b> Deploy maintenance support here.</p>
5		<p><b>Forklift Pocket</b> Insert fork fully into pocket to lift aerial platform.</p>

Labels - Models 6826 & 6832

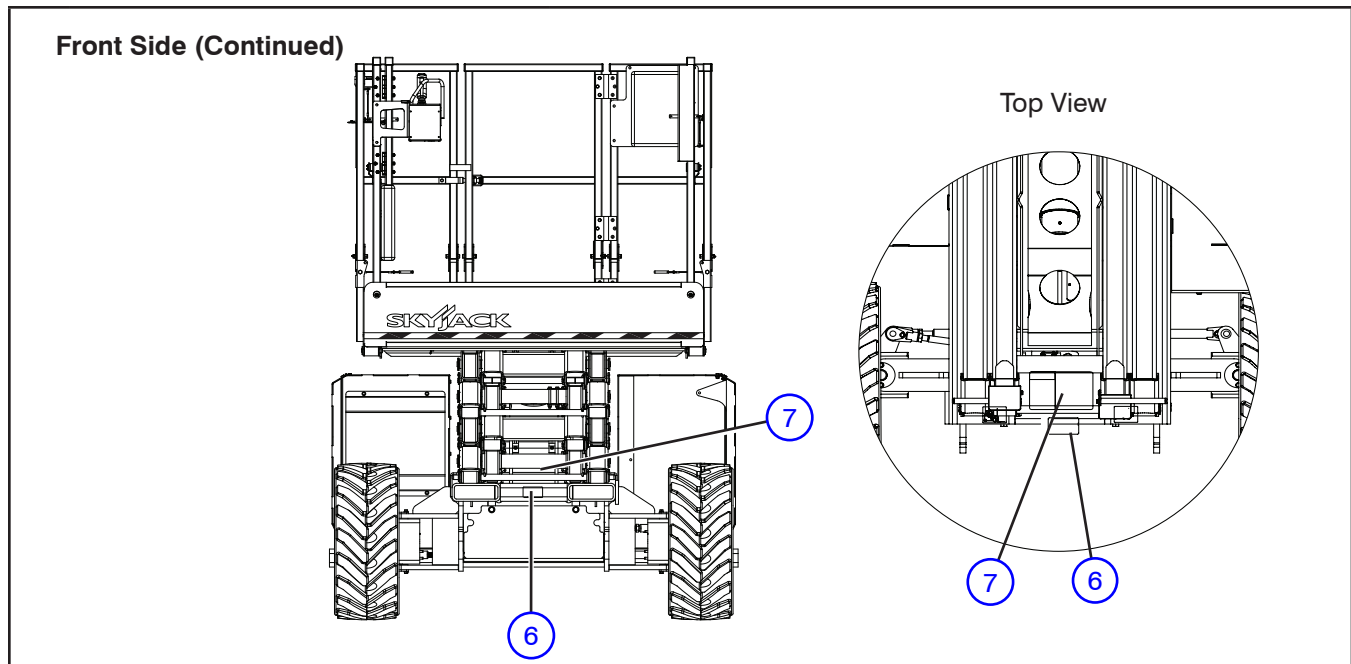



No.	Label Pictorial	Description
6		<p><b>Lift and Tie Down Points</b></p> <p>Only use these points for lifting or tying down.</p>
7		<p><b>How to engage maintenance support for inspection or maintenance.</b> Refer to Operating manual.</p> <ol style="list-style-type: none"> <li>1. Remove all material from platform.</li> <li>2. Raise platform until there is adequate clearance to swing down maintenance support.</li> <li>3. Swing maintenance support down from storage bracket into a vertical position. Lower platform until the bottom end of maintenance support rests on the lower cross bar.</li> <li>4. Maintenance support is now secured.             <ul style="list-style-type: none"> <li>(A) Turn main power disconnect switch to off position.</li> <li>(B) Perform inspection/maintenance.</li> </ul> </li> <li>5. Turn main power disconnect switch to on position.</li> <li>6. Raise platform until there is adequate clearance to swing up maintenance support.</li> <li>7. Swing maintenance support up and place into storage bracket.</li> <li>8. Ensure platform is fully lowered.</li> </ol>

Labels - Models 6826 & 6832

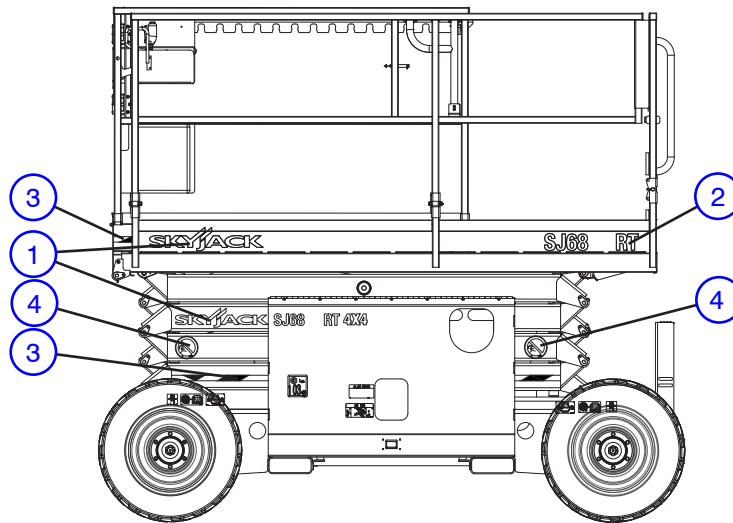
Left Side

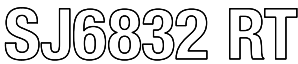



No.	Label Pictorial	Description
1		<p><b>Skyjack Logo</b> Skyjack</p>
2		<p><b>Model Number*</b> Product Identifier *Model number will vary, may not be as shown.</p>
3		<p><b>Caution Tape Stripe</b> Caution stripe</p>
4		<p><b>Keep Clear</b> Keep clear. Stay away from aerial platform when in operation.</p>

Labels - Models 6826 & 6832

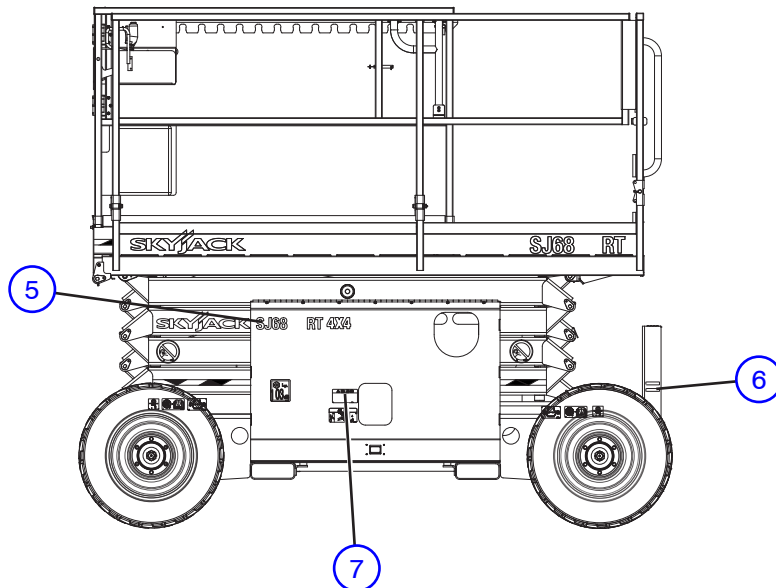
Left Side (Continued)

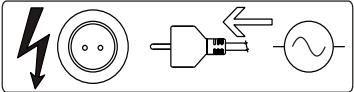



No.	Label Pictorial	Description
5		<p><b>Model Number*</b></p> <p>Product Identifier *Model number will vary, may not be as shown.</p>
6		<p><b>Connect AC Supply</b></p> <p>Connect AC supply here.</p>
7		<p><b>Winching/Towing/Pushing Procedure</b> Refer to Operating manual.</p> <ol style="list-style-type: none"> <li>1. Block or chalk wheels to prevent aerial platform from rolling.</li> <li>2. Turn main power disconnect switch to off position.</li> <li>3. Locate brake valve and pump.</li> <li>4. Push in black knob.</li> <li>5. Pump by pushing red knob in and out until firm resistance is felt. Brake is now released.</li> <li>6. Push/tow/winch to desired location.</li> <li>7. Block or chalk wheels to prevent aerial platform from rolling.</li> <li>8. Reset brake by pulling out black knob.</li> </ol>

Labels - Models 6826 & 6832

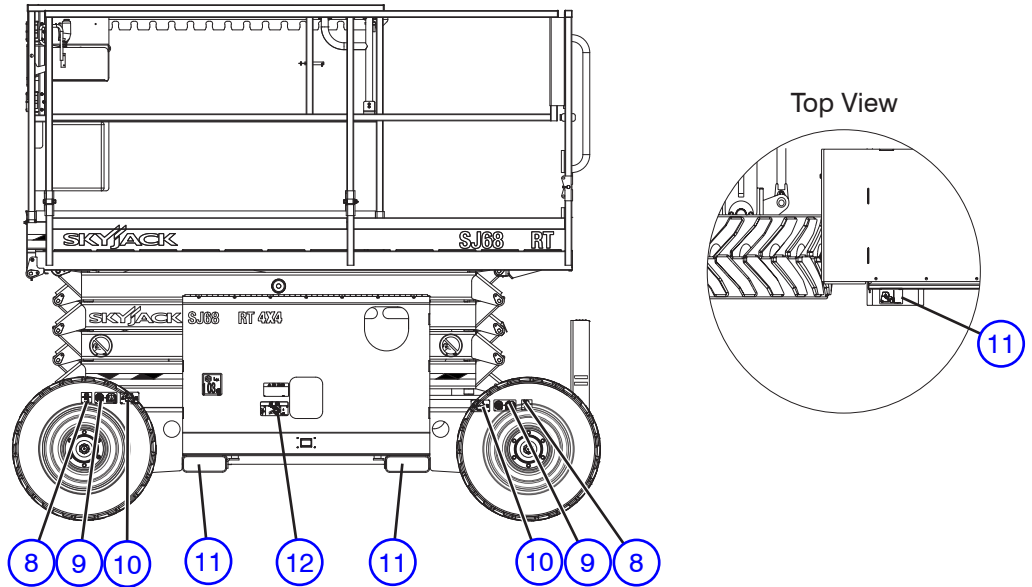
Left Side (Continued)

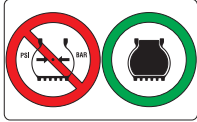
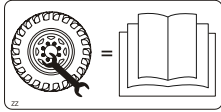

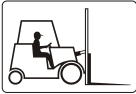
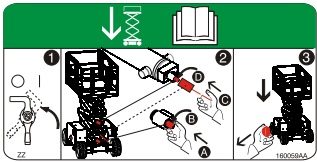

No.	Label Pictorial	Description
8		<p><b>Foam-filled Tire</b> Indicates foam-filled tire only.</p>
9		<p><b>Wheel Specifications</b> Refer to manual for wheel type, offset, pressure and torque.</p>
10		<p><b>Wheel Load</b> Indicates rated wheel load.</p>
11		<p><b>Forklift Pocket</b> Insert fork fully into pocket to lift aerial platform.</p>
12		<p><b>Emergency Lowering Procedure</b> Refer to Operating manual.</p> <ol style="list-style-type: none"> <li>1. Turn main power disconnect switch to off position.</li> <li>2. To open the lift cylinder holding valves located at the bottom of each cylinder: if higher reach required, use emergency lowering rod located on the top of the base to:                         <ol style="list-style-type: none"> <li>(A) push</li> <li>(B) turn knurled knob counterclockwise.</li> </ol> </li> <li>3. To lower the platform, pull out emergency lowering valve located on the outside of the hydraulic tray.</li> </ol>



Labels - Models 6826 & 6832

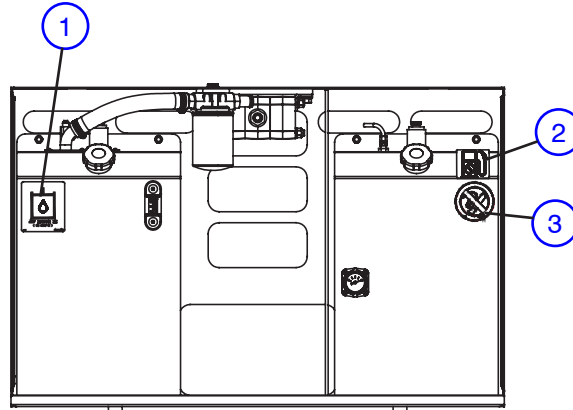

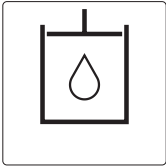
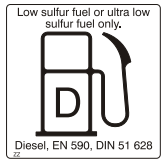

Hydraulic/Fuel Compartment

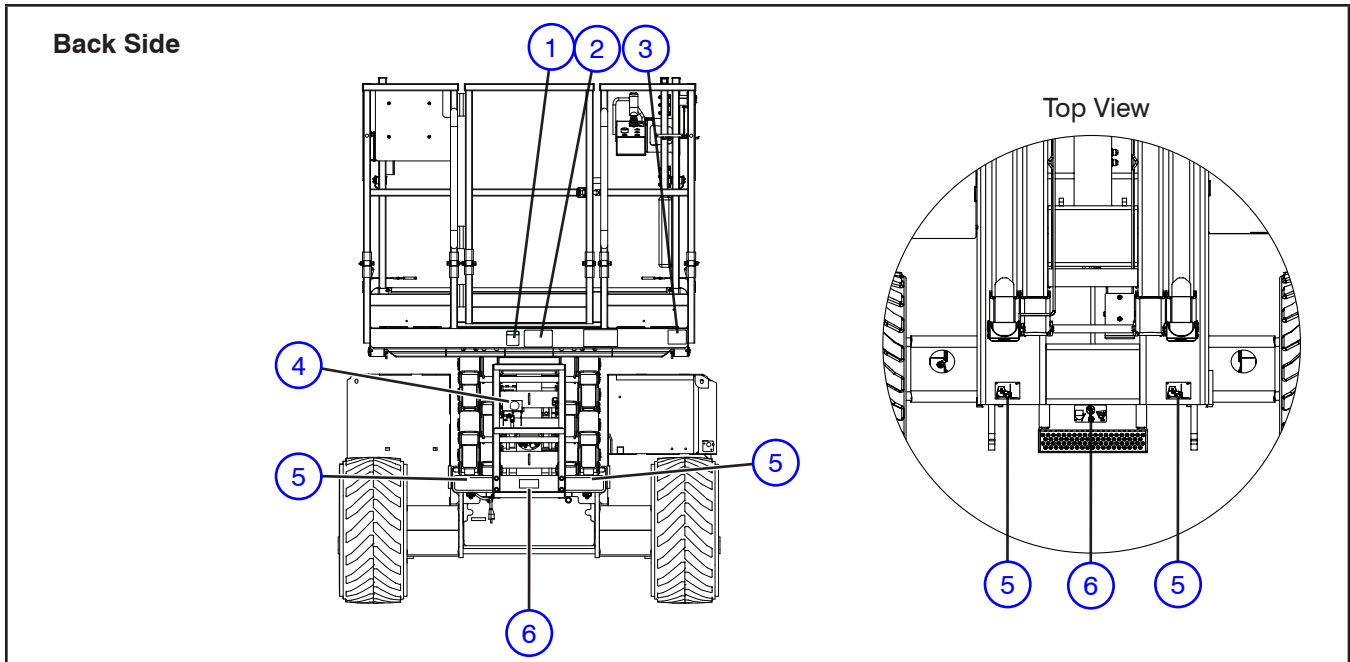

No.	Label Pictorial	Description
1		<p><b>Hydraulic Oil ATF Dexron III</b></p> <p>Replace hydraulic fluid with ATF Dexron III only.</p>
2		<p><b>Diesel (If Equipped)</b></p> <p>Use diesel fuel only.</p>
		<p><b>Unleaded Fuel</b></p> <p>Use unleaded gasoline only.</p>
3		<p><b>No Smoking</b></p> <p>Do not smoke near this location.</p>

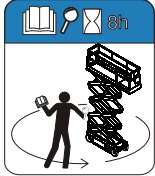
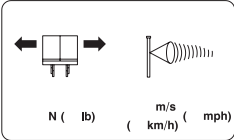

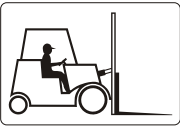
Labels - Models 6826 & 6832

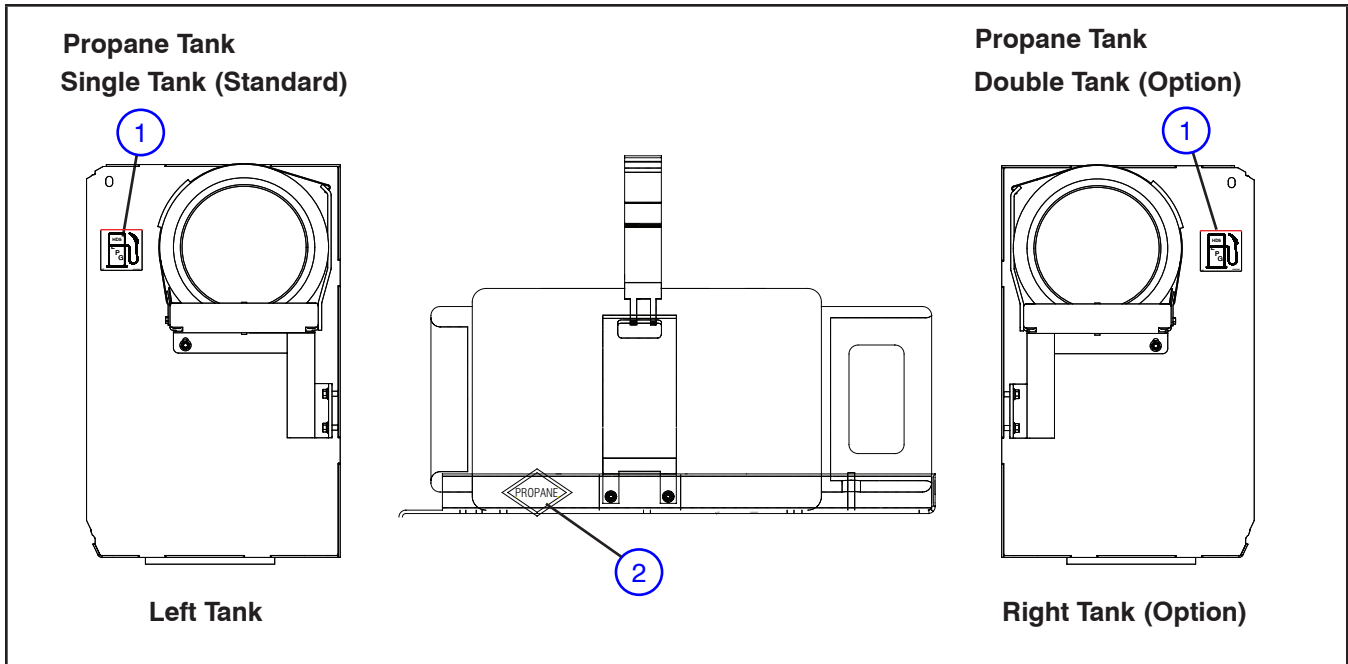

No.	Label Pictorial	Description
1		<p><b>Operator's Daily Inspection.</b> Refer to the Operating manual.</p> <p>Perform visual inspection and function tests at the beginning of each shift. Refer to <a href="#">Section 4: Maintenance and Inspection Schedule</a>.</p>
2		<p><b>Horizontal Load Rating</b></p> <p>Apply no more than the indicated side load. Operate below indicated wind speed only.</p>
3		<p><b>No Jewelry</b></p> <p>Caution - Do not wear jewelry.</p>
4		<p><b>Warning - Do Not Alter</b></p> <p>Do not alter or disable limit switches or other safety devices.</p>
5		<p><b>Forklift Pocket</b></p> <p>Insert fork fully into pocket to lift aerial platform.</p>
6		<p><b>Lift and Tie Down Points</b></p> <p>Only use these points for lifting or tying down.</p>

Labels - Models 6826 & 6832

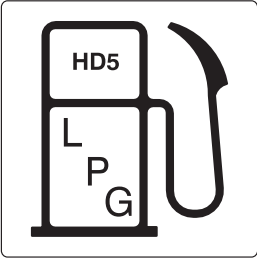

No.	Label Pictorial	Description
1		<p><b>Liquid Propane</b> Use liquid propane only.</p>
2		<p><b>Propane</b> Indicates propane storage location.</p>

Labels - Models 6826 & 6832

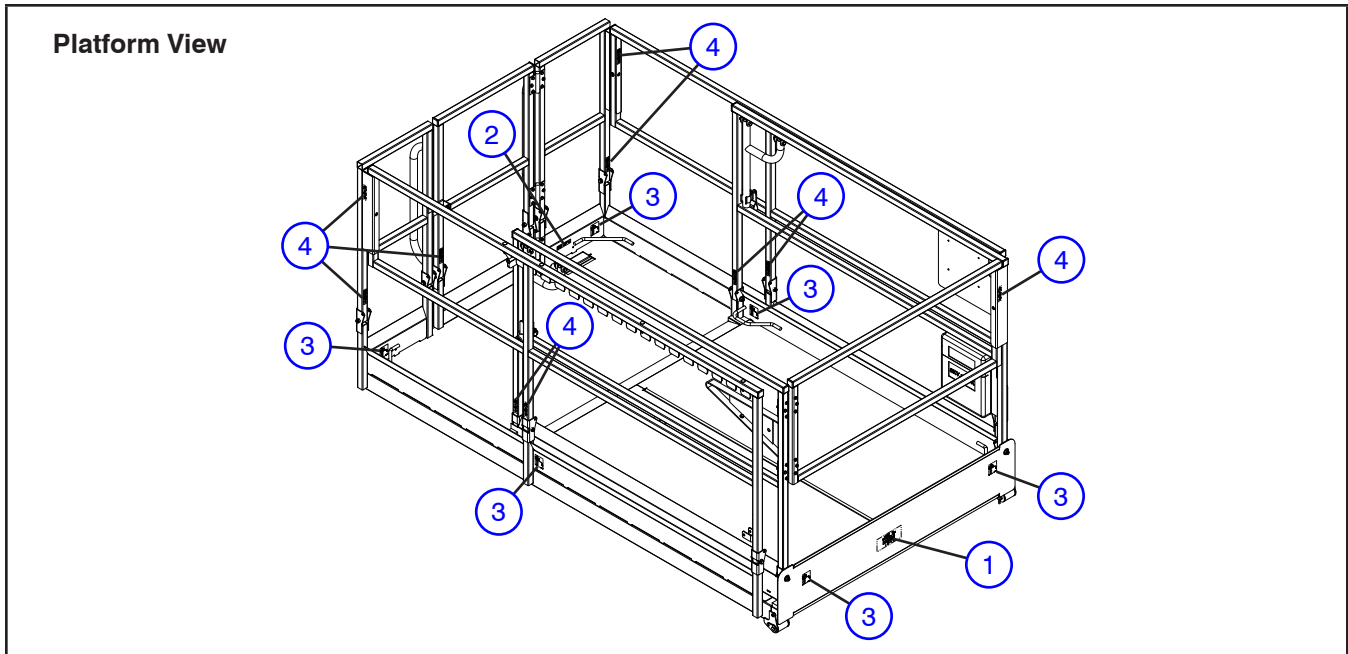

No.	Label Pictorial	Description
1	<p>The pictorial shows two configurations of a scissor lift platform. The first configuration shows two people and a box on the platform, with arrows pointing down to the text '( kg / lb ) + ( kg / lb )'. The second configuration shows one person and a box on the platform, with arrows pointing down to the text '( kg / lb )'.</p>	<p><b>Platform Capacity</b></p> <p>Platform capacity label for 6826RT and 6832RT respectively</p> <p>Rated work load in each configuration is as shown. Rated work load includes the weight of both personnel and material. Maximum number of people in each configuration is as shown. Do not exceed total weight or maximum number of people. Load platform uniformly.</p>
2	<p>The pictorial shows a lightning bolt symbol, a power plug, and a power outlet, indicating the AC power connection point.</p>	<p><b>Connect AC Supply</b></p> <p>Connect AC supply here.</p>
3	<p>The pictorial shows a person wearing a safety harness, indicating the anchorage point for safety harness tethers.</p>	<p><b>Harness Anchorage</b></p> <p>Anchor safety belt/harness tethers here.</p>
4	<p>The pictorial shows a warning sign for falling hazard, indicating the location of the hinged railing pins.</p>	<p><b>Railing Pins (Vertical)</b></p> <p>WARNING! Falling Hazard. Ensure hinged railing is pinned.</p>

Labels - Models 6826 & 6832

Platform Control Console

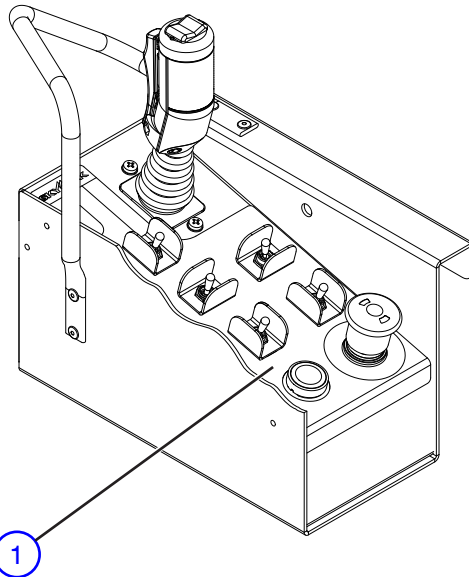

No.	Label Pictorial	Description
1		<p><b>Platform Control Console</b></p> <p>Squeeze “” trigger to enable controller.</p> <p>Operate “” rocker switch to steer.</p> <p>Move controller forward “” to raise or backward “” to lower platform.</p> <p>Move controller forward “” to drive forward or backward “” to drive reverse.</p> <p>Select either “” drive mode with low speed (high torque) or “” drive mode with high speed (low torque).</p> <p>Select either “” lift mode or “” drive mode.</p> <p>Select either “” low or “” high engine throttle speed.</p> <p>Select and hold “” to start engine.</p> <p>Select and hold “” to operate choke (dual fuel) or “” glow plugs (diesel).</p> <p>Push “” to sound horn.</p> <p>Push “” to stop engine and disable controls (Emergency Stop).</p> <p>Light indicates controls enabled.</p> <p>Read “” operating manual.</p>

Labels - Models 6826 & 6832

Lift Cylinders

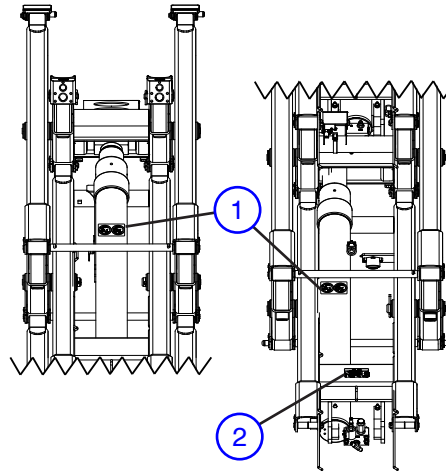



No.	Label Pictorial	Description
1	<p>The pictorial shows two circular icons. The left icon, with a green border, shows a hand correctly installing an orifice into a hole. The right icon, with a red border and a diagonal slash, shows a hand incorrectly installing an orifice into a different hole.</p>	<p><b>Orifice Installed</b> Orifice installation warning</p>
2	<p>The pictorial shows three numbered steps for emergency lowering. Step 1 shows the power disconnect switch being turned off. Step 2 shows hands operating the emergency lowering rod (A) and knob (B). Step 3 shows the emergency lowering valve being pulled out. A green banner at the top shows the scissor lift platform lowering.</p>	<p><b>Emergency Lowering Procedure</b> Refer to Operating manual.</p> <ol style="list-style-type: none"> <li>1. Turn main power disconnect switch to off position.</li> <li>2. To open the lift cylinder holding valves located at the bottom of each cylinder: if higher reach required, use emergency lowering rod located on the top of the base to: (A) push (B) turn knurled knob counterclockwise.</li> <li>3. To lower the platform, pull out emergency lowering valve located on the outside of the hydraulic tray.</li> </ol>

Labels - Models 6826 & 6832 - Options and Attachments

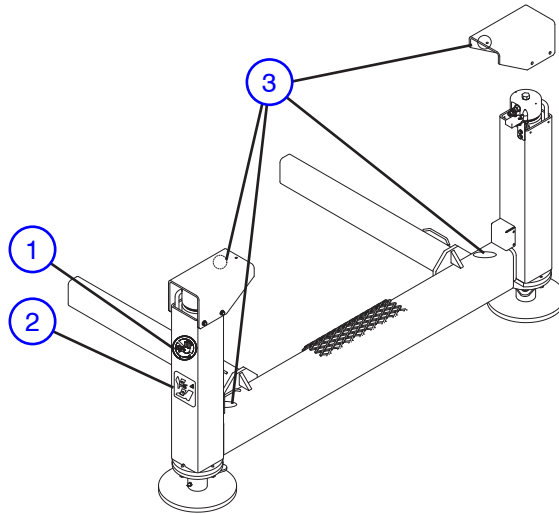
Outriggers



No.	Label Pictorial	Description
1		<p><b>Keep Clear</b> Keep clear. Stay away from aerial platform when in operation.</p>
2		<p><b>Crushing Hazard</b> Danger - Crushing hazard</p>
3		<p><b>Warning - Do Not Alter</b> Do not alter or disable limit switches or other safety devices.</p>

Labels - Models 6826 & 6832 - Options and Attachments

Outrigger Control Console

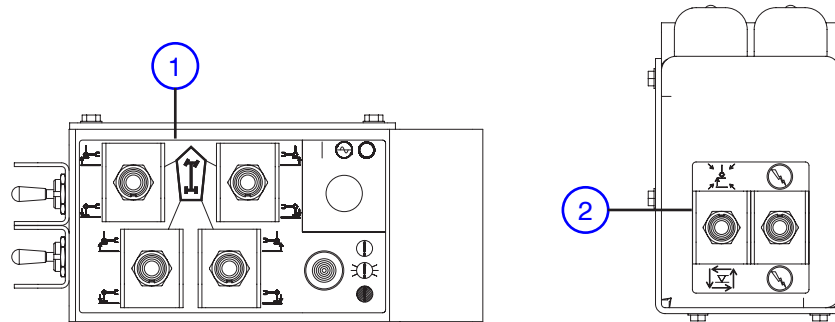

No.	Label Pictorial	Description
1		<p><b>Manual Outrigger Control Console with Generator</b></p> <p>Select “” retract or “” extend for each outrigger.</p> <p>Select “” to enable or “” to disable generator.</p> <p>Indicates leveling system status:</p> <ul style="list-style-type: none"> <li> <b>Off:</b> The outriggers are fully retracted.</li> <li> <b>Flashing Rapidly:</b> The outriggers are extending but the platform is not level.</li> <li> <b>Flashing:</b> The outriggers are extended but the platform is not yet level.</li> <li> <b>Solid:</b> The outriggers are extended and the platform is level.</li> </ul>
2		<p><b>Automatic Outrigger Control Console</b></p> <p>Select “” to retract all outriggers or “” to extend all outriggers with automatic leveling.</p> <p>Select “” to enable manual or automatic outrigger controls.</p>



Labels - Models 6826 & 6832 - Options and Attachments

Tire Sealant, Air Supply and Inverter Options

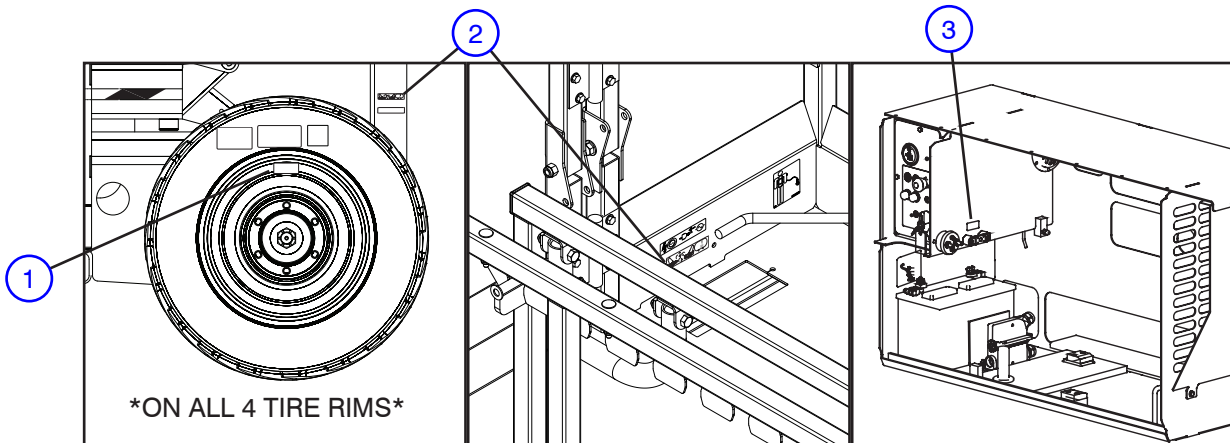

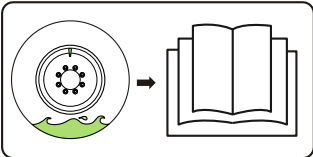
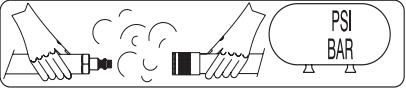
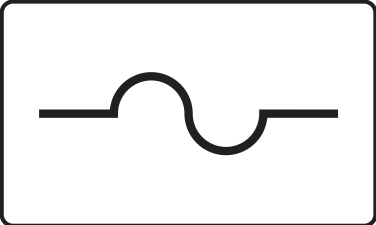
No.	Label Pictorial	Description
1		<p><b>Tire Sealant</b></p> <p>Indicates that tire sealant is present inside the tires.</p>
2		<p><b>Connect Air Supply</b></p> <p>Connect platform air supply here.</p>
3		<p><b>Fuse</b></p> <p>Fuse location</p>



## **California Proposition 65**

**Engine exhaust and some of its constituents are known to the State of California to cause cancer, birth defects, and other reproductive harm.**

Battery posts, terminals, and related accessories contain lead and lead compounds, chemicals known to the State of California to cause cancer, birth defects, and other reproductive harm.

**WASH HANDS AFTER HANDLING.**

**SKYJACK**<sup>™</sup>

[www.skyjack.com](http://www.skyjack.com)