



3 TON SUPER LOW SUPER HIGH GARAGE JACK

SPECIFICATIONS

Model	Jack Dimensions	Max Load Capacity	Lifting Range	Saddle Dimensions	Jack Weight
3 Ton Super Low Super High Garage Jack	34.06 in. x 14.37 in. x 6.30 in.	6,000 lbs	3.25 to 24 in.	4.25 in. Diameter	100.2 lbs.

Tool Set Up

ATTACHING THE HANDLE

1. Fasten the Upper handle to the Lower Handle.
2. Loosen the Set Screw and insert the assembled Handle into the Handle Socket.
3. Tighten the Set Screw.

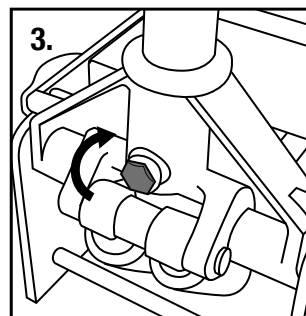
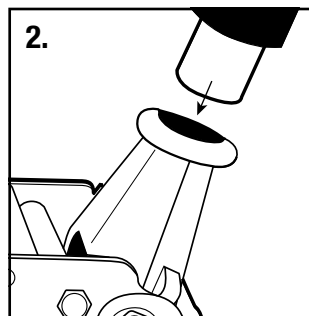
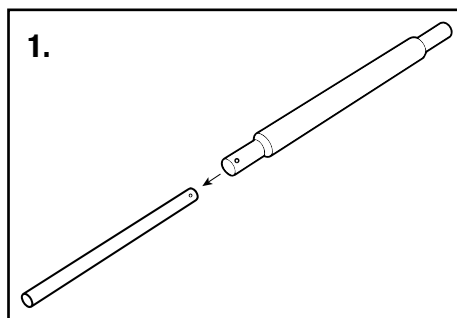
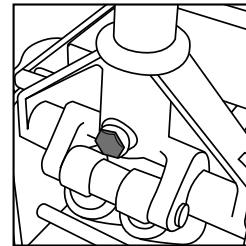

BLEEDING

1. Loosen the Fill Screw.
2. Insert the Handle into the Handle Socket to operate the Release Valve.
3. Turn the Handle counterclockwise to open the valve.
4. Pump the Handle up and down quickly several times to purge air from the system.
5. Tighten the Fill Screw.

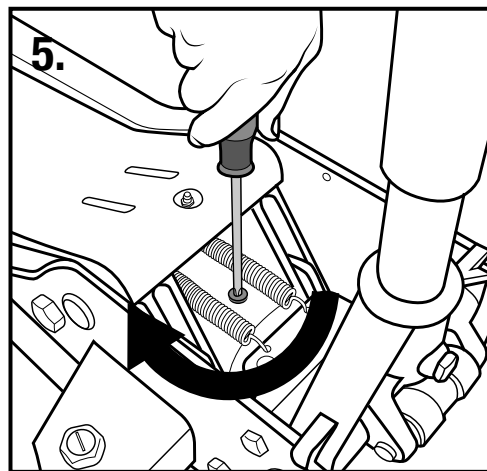
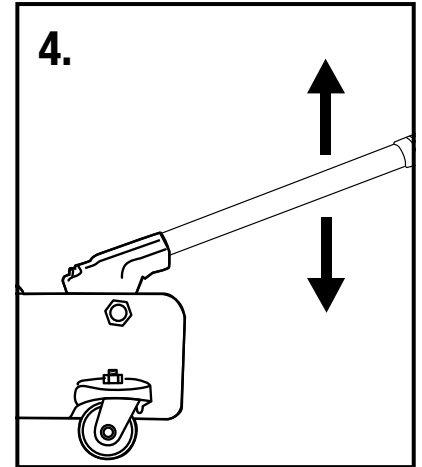
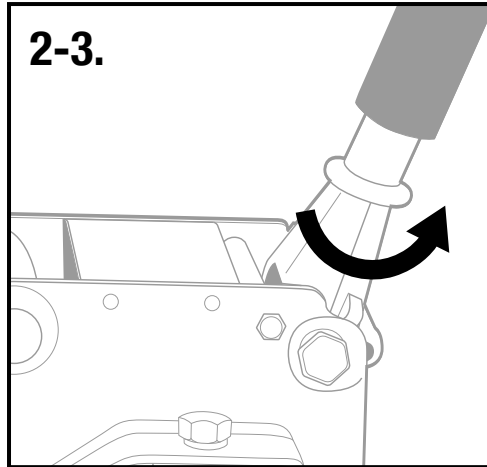
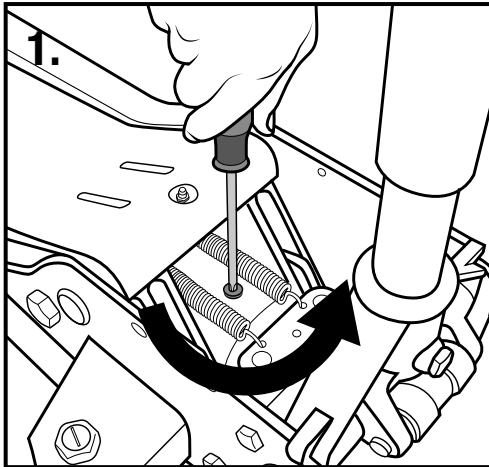

ADDING OIL

1. Remove the Fill Screw. (See above for Fill Screw Location)
2. Add high grade hydraulic fluid into the Fill Screw slowly until the oil reaches the top of the oil fill hole.
3. Replace the Fill Screw.



NOTE: Do not touch the handle when adding hydraulic oil.