



Operator's Manual
Original Operating Instructions
Edger

SN



Includes models:

23275

24000

Get parts online at
www.getearthquake.com



P/N: 22945
ECN: 10900
REV2: 11/16/16
© 2016 Ardisam, Inc.
All Rights Reserved

INTRODUCTION

Congratulations on your investment in quality. Thank you for purchasing an edger from *Earthquake®*. We have worked to ensure that your product meets the highest standards for usability and durability. With proper care, your edger will provide many years of service.

Please read this entire manual before installation and use. Earthquake reserves the right to change, alter or improve the product and this document at any time without prior notice.

CONTENTS

Introduction/Registration and Service	2
Warnings.....	3
General Safety Rules.....	4
Safety Precautions.....	5
Service Safety/Symbols.....	6
Safety Decals.....	7
Features and Controls.....	8
Specifications.....	9
Assembly.....	10-11
General Operation	12-13
Edging Tips	14
Slope Guide.....	14
Maintenance	15
Transporting and Storage	16
Troubleshooting	16
Troubleshooting Guide	17
Illustrated Parts Breakdown.....	18-22
Warranty	23

When contacting your authorized dealer or Earthquake for replacement parts, service, or information you MUST have these numbers. Do not take this product back to the store from which it was purchased

Record your model name/number, manufacturer's identification numbers, and engine serial numbers in the space provided for easy access.

NOTE: For location of engine identification numbers, refer to the engine owner's manual.

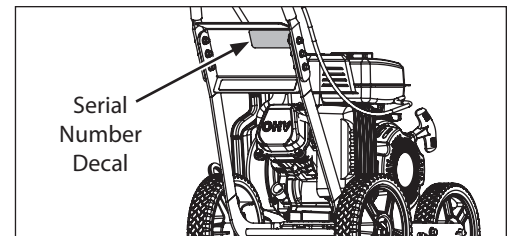

REGISTRATION AND SERVICE

Record the product number and serial number in the space provided for easy reference when ordering parts or requesting technical support. Excluding emissions-related warranty items, the warranty is valid only if the completed registration is received by Earthquake within 30 days of purchase. **(SEE WARRANTY SECTION FOR MORE INFORMATION.)** You can register your warranty online by visiting www.getearthquake.com, or by mailing it to: Warranty Department, 1160 Eighth Avenue, Cumberland, WI 54829. If you do not have access to www.getearthquake.com, call our customer service department at (800) 345-6007 Mondays through Fridays from 8 a.m. to 5 p.m. CST.

OWNERSHIP RECORDS		
Owner's Name:		
Owner's Address:		
City:	State/Province:	Zip Code/Postal Code:
Model Number:	Serial Number:	
Engine Model:	Engine Serial Number:	
Date of Purchase:	Notes:	

This manual may contain information for several models. Read and keep this manual for future reference. This manual contains important information on SAFETY, ASSEMBLY, OPERATION, AND MAINTENANCE. The owner must be certain that all the product information is included with the unit. This information includes the MANUAL, the REPLACEMENT PARTS and the WARRANTIES. This information must be included to make sure state laws and other laws are followed. This manual should remain with the unit even if it is resold.

WARNINGS AND SAFETY PRECAUTIONS

Owner's Responsibility

Accurate assembly, and safe and effective use of the edger is the owner's responsibility.

- Read and follow all safety instructions.
- Carefully follow all assembly instructions.
- Maintain the edger according to directions and schedule included in this operator's manual.
- Ensure that anyone who uses the edger is familiar with all controls and safety precautions.

Special Messages

Your manual contains special messages to bring attention to potential safety concerns, machine damage as well as helpful operating and servicing information. Please read all the information carefully to avoid injury and machine damage.

NOTE: General information is given throughout the manual that may help the operator in the operation or service of the machine.

Important Safety Precautions

Please read this section carefully. Operate the edger according to the safety instructions and recommendations outlined here and inserted throughout the text. Anyone who uses this edger must read the instructions and be familiar with the controls. Learn how to control the edger at all times.



This symbol points out important safety instructions which if not followed could endanger your personal safety. Read and follow all instructions in this manual before attempting to operate this equipment.



WARNING

WARNING INDICATES A HAZARD WHICH, IF NOT AVOIDED, COULD RESULT IN DEATH OR SERIOUS INJURY AND/OR PROPERTY DAMAGE.



CAUTION

CAUTION INDICATES YOU CAN BE HURT OR YOUR EQUIPMENT DAMAGED IF THE SAFETY INSTRUCTIONS THAT FOLLOW THIS SIGNAL WORD ARE NOT OBEYED.



IMPORTANT

INDICATES HELPFUL INFORMATION FOR PROPER ASSEMBLY, OPERATION, OR MAINTENANCE OF YOUR EQUIPMENT.



WARNING

CALIFORNIA PROPOSITION 65 WARNING

ENGINE EXHAUST FROM THIS PRODUCT CONTAINS CHEMICALS KNOWN TO THE STATE OF CALIFORNIA TO CAUSE CANCER, BIRTH DEFECTS, OR OTHER REPRODUCTIVE HARM.



WARNING

YOU MUST READ, UNDERSTAND AND COMPLY WITH ALL SAFETY AND OPERATING INSTRUCTIONS IN THIS MANUAL BEFORE ATTEMPTING TO SETUP AND OPERATE YOUR MACHINE.

FAILURE TO COMPLY WITH ALL SAFETY AND OPERATING INSTRUCTIONS CAN RESULT IN LOSS OF MACHINE CONTROL, SERIOUS PERSONAL INJURY TO YOU AND/OR BYSTANDERS, AND RISK OF EQUIPMENT AND PROPERTY DAMAGE. THE TRIANGLE IN THE TEXT SIGNIFIES IMPORTANT CAUTIONS OR WARNINGS WHICH MUST BE FOLLOWED.



Intended Use / Foreseeable Misuse

This is a motorized, walk-behind edger used for maintaining and trimming unwanted weeds and grass from areas next to concrete or other landscaping items. This edger is not to be used to cut wood or concrete. It is pedestrian controlled. It has a petrol-fuelled internal combustion engine that powers the cutting wheel. It shall not be used for any other purpose.

GENERAL SAFETY RULES

- Read, understand, and follow all instructions on the machine and in the manual(s). Be thoroughly familiar with the controls and the proper use of the machine before starting.
- Use this equipment for its intended purpose only.
- Familiarize yourself with all of the safety and operating decals on this equipment and on any of its attachments or accessories.
- Do not put hands or feet near or under rotating parts.
- Only allow responsible individuals who are familiar with the instructions to operate the machine. Do not allow children to operate this machine. Keep small children away from the area while in use. Do not allow adults to operate the machine without proper instruction.
- Thoroughly inspect the area where the machine is to be used and remove all foreign objects. Your equipment can propel small objects at high speed causing personal injury or property damage. Stay away from breakable objects, such as house windows, automobiles, greenhouses, etc.
- Wear appropriate clothing such as a long-sleeved shirt or jacket. Also wear long trousers or slacks. Do not wear shorts. Never wear sandals, sneakers, or open shoes, and never operate the machine with bare feet.
- Do not wear loose clothing or jewelry. They can get caught in moving parts. Always keep hands, feet, hair and loose clothing away from any moving parts on engine and machine.
- Always wear safety goggles or safety glasses with side shields when operating the machine to protect your eyes from foreign objects which can be thrown from the unit. Always wear a protective hearing device.
- Always wear work gloves and machine safety shoes during operation. Wear footwear that will improve footing on slippery surfaces. Leather work shoes or short boots work well for most people. These will protect the operator's ankles and shins from small sticks, splinters, and other debris.
- It is advisable to wear protective headgear to prevent the possibility of being struck by small flying particles, or being struck by low hanging branches, twigs, or other objects which may be unnoticed by the operator.
- Do not operate the machine without proper guards or other safety protective devices in place.
- See manufacturer's instructions for proper operation and installation of accessories. Only use accessories approved by the manufacturer.
- Operate only in daylight or good artificial light.
- Do not operate product when fatigued or under the influence of alcohol, drugs or other medication which can cause drowsiness or affect your ability to operate this machine safely.
- Never operate machine in wet grass. Always be sure of your footing; keep a firm hold on the handle and walk; never run.

- Watch for traffic whenever you are operating near, or when crossing roads.
- If the equipment should start to vibrate abnormally, stop the engine (motor), disconnect the spark plug wire and prevent it from touching the spark plug. Check immediately for cause. Vibration is generally a warning of trouble. If the noise or vibrations of the machine increase, stop immediately and perform an inspection.
- Never leave the machine unattended when the engine is running.
- Regularly inspect the machine. Make sure parts are not bent, damaged or loose.
- Temperature of muffler and nearby areas may exceed 150° F (65° C). Allow muffler and engine areas to cool before touching. Never pick up or carry the machine while the engine is running.
- Prolonged exposure to noise and vibration from gasoline engine-powered equipment should be avoided. Take intermittent breaks and/or wear ear protection from engine noise as well as heavy work gloves to reduce vibration in the hands.
- Keep all screws, nuts and bolts tight.
- Do not transport the machine from one place to another with the engine running.
- When moving the packaged machine, always do so with a partner.
- Check local regulations for age restrictions on use of this machine.
- Stay away from rotating parts. Place protective covers over rotating parts.

PRODUCT-SPECIFIC SAFETY RULES

- Do not edge above underground utilities, including water lines, gas lines, electric cables, or pipes. Do not operate the machine on terrain/soil with large rocks and foreign objects which can damage the equipment.
- After striking a foreign object, stop the engine. Remove the wire from the spark plug. Inspect the machine for damage. If damaged, repair before starting and operating the machine.
- The blade of the edger should not rotate when the engine is idling. If it does rotate when engine is idling, contact *Earthquake®* for instructions.
- If an object becomes lodged in the blade guard area, turn engine off, remove the wire from the spark plug and secure, allow to cool before attempting to remove the foreign object.
- Use edger only for edging along flower beds, terraces, sidewalks and curbs. Trim along buildings trees, walks, marker hedges and fences.

ENGINE SAFETY PRECAUTIONS

Preventing Carbon Monoxide Poisoning

- Never try to ventilate engine exhaust indoors. Carbon monoxide can reach dangerous levels very quickly.
- Never run engine outdoors where exhaust fumes may be pulled into a building.
- Never run engine outdoors in a poorly ventilated area where the exhaust fumes may be trapped and not easily taken away. (Examples include: in a large hole or areas where hills surround your working area.)
- Never run engine in an enclosed or partially enclosed area. (Examples include: buildings that are enclosed on one or more sides, under tents, car ports or basements.)
- Never point the exhaust muffler towards anyone. People should always be many feet away from the operation of the engine and its attachments.
- Do not change the engine governor settings or over-speed the engine.
- Always keep materials and debris clear of muffler guard and other hot engine parts.
- Always make sure the exhaust pipe is free of foreign objects.

Gasoline Fires and Handling Fuel Safely

- Use extra care in handling gasoline and other fuels. They are flammable and vapors are explosive.
- When storing extra fuel be sure that it is in an appropriate container and away from any fire hazards. Prevent fire and explosion caused by static electric discharge. Use only nonmetal, portable fuel containers approved by the Underwriter's Laboratory (U.L.) or the American Society for Testing & Materials (ASTM).
- Always fill fuel tank outside in a well ventilated area. Never fill your fuel tank with fuel indoors. (Examples include: basement, garage, barn, shed, house, porch, etc.) Never fill tank near appliances with pilot lights, heaters, or other ignition sources. If the fuel has to be drained, this should be done outdoors and with the proper equipment. The drained fuel should be stored in a container specifically designed for fuel storage or it should be disposed of carefully.
- Never remove the fuel cap or add fuel with the engine running. Stop engine and allow to cool before removing the fuel cap/and or refilling the engine.
- Do not smoke near or while handling engine fuel.
- Never drain fuel from engine in an enclosed area.
- During storage, tightly screw down fuel cap.
- Never pour fuel from engine fuel tank.
- Never siphon fuel by mouth to drain fuel tank.
- Always have an adult fill the fuel tank and never allow children to fill the engine.

WARNING

ENGINES GIVE OFF CARBON MONOXIDE, AN ODORLESS, COLORLESS, POISONOUS GAS. CARBON MONOXIDE MAY BE PRESENT EVEN IF YOU DO NOT SMELL OR SEE ANY ENGINE EXHAUST. BREATHING CARBON MONOXIDE CAN CAUSE NAUSEA, FAINTING OR DEATH, IN ADDITION TO DROWSINESS, DIZZINESS AND CONFUSION.

IF YOU EXPERIENCE ANY OF THESE SYMPTOMS, SEEK FRESH AIR AND MEDICAL ATTENTION IMMEDIATELY.

START AND RUN ENGINE OUTDOORS. DO NOT START OR RUN ENGINE IN ENCLOSED AREA, EVEN IF DOORS OR WINDOWS ARE OPEN.

HOT GASES ARE A NORMAL BY-PRODUCT OF COMBUSTION. FOLLOW ALL SAFETY INSTRUCTIONS TO PREVENT BURNS AND FIRES.

DO NOT ALTER/MODIFY ENGINE:

NEVER ALTER OR MODIFY THE ENGINE FROM THE FACTORY. SERIOUS INJURY OR DEATH MAY OCCUR IF ENGINE IS MODIFIED OR ALTERED.

WHEN WORKING ON OR REPLACING PARTS FOR THE ENGINE OR PRODUCT, YOU MUST ALWAYS DISCONNECT SPARK PLUG WIRE FROM THE SPARK PLUG AND KEEP IT AWAY FROM THE SPARK PLUG.

- Never allow an adult or anyone under the influence of drugs or alcohol to fill the engine.
- When storing gasoline or equipment with fuel in the tank, store away from furnaces, stoves, water heaters or other appliances that have a pilot light or other ignition source because they can ignite gasoline vapors.

Prevention of Burns and Fires

- Never remove the muffler guard from the engine.
- Never touch the muffler guard because it is extremely hot and will cause severe burns.
- Never touch parts of the engine that become hot after operation.
- Always keep materials and debris away from muffler guard and other hot parts of the engine to avoid fires.

Burns and Fires

- The muffler, muffler guard and other parts of the engine become extremely hot during the operation of the engine. These parts remain extremely hot after the engine has stopped.
- Do not use engine around dry brush, cloth rags, or other flammable materials.
- Never operate the engine without the muffler guard in place.
- The engine exhaust becomes very hot during operation. Keep engine at least three feet away from buildings and other equipment during operation.

SERVICE SAFETY

- Always stop the engine whenever you leave the equipment, before cleaning, repairing or inspecting the unit. Engine should be turned off and cool, spark plug wire must be removed from spark plug before any repairs or adjustments are attempted. Never make adjustments or repairs with the engine (motor) running. Disconnect the spark plug wire, and keep the wire away from the plug to prevent accidental starting.
- Always wear eye protection when you make adjustments or repairs.
- Keep all nuts and bolts tight and keep equipment in good condition. Never tamper with safety devices. Check their proper operation regularly.
- When servicing or repairing the engine, do not tip the engine over or up unless specifically instructed to do so in this manual. Service and repair procedures can be done with the engine in an upright position. Some procedures will be easier if the engine is lifted on a raised platform or working surface.
- To reduce fire hazard, keep engine free of grass, leaves, or other debris build-up. Clean up oil or fuel spillage. Allow engine to cool before storing.
- Stop and inspect the equipment if you strike an object. Repair, if necessary, before restarting.
- Clean and replace safety and instruction decals as necessary.
- Inspect engine before storage. When not in use, disconnect spark plug lead and store indoors in a dry place locked or otherwise inaccessible to children.
- Use only original equipment parts from *Earthquake®*, including all nuts and bolts.

CONTROL AND OPERATING SYMBOLS

Pictured below are control and operating symbols on the unit or in this manual. Before you operate your unit, learn and understand the purpose for each symbol.

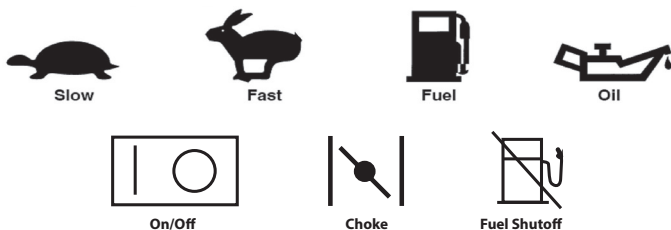

SAFETY OR HAZARD SYMBOLS



- A: Warning!
- B: Read Owner's Manual Before Operating Machine.
- C: Only Operate When at a Safe Distance From Others.
- D: Remove Objects that Could Be Thrown By This Machine.
- E: Dangerous Moving Parts.
- F: Be Aware of Moving Parts.
- G: Wear Ear and Eye Protection At All Times.
- H: Do Not Service or Adjust Moving Parts Unless Engine is Stopped and Spark Plug Wire is Disconnected.
- I: Dress Appropriately And Wear Sturdy Footwear.
- J: Toxic Fumes—Do Not Operate in Unventilated Areas.
- K: Hot Surfaces.
- L: Fire Hazards.
- M: Do Not Use In Thunderstorms—For severe weather, stop operation of this machine and seek shelter.
- N: Keep Hands at a Safe Distance from Blade.
- O: Keep Feet at a Safe Distance from Blade.
- P: Do Not Use Above Underground Utility Lines And Pipes.
- Q: Shock Hazard.
- R: Hot! Do Not Touch!

SAFETY DECALS

This unit has been designed and manufactured to provide you with the safety and reliability you would expect from an industry leader in outdoor power equipment manufacturing.

Although reading this manual and the safety instructions it contains will provide you with the necessary basic knowledge to operate this equipment safely and effectively, we have placed several safety labels on the unit to remind you of this important information while you are operating your unit.

All DANGER, WARNING, CAUTION and instructional messages on your unit should be carefully read and obeyed. Personal bodily injury can result when these instructions are not followed. The information is for your safety and it is important! The safety decals below are on your unit.

If any of these decals are lost or damaged, replace them at once. See your local dealer or contact *Earthquake®* directly for replacements. These labels are easily applied and will act as a constant visual reminder to you, and others who may use the equipment, to follow the safety instructions necessary for safe, effective operation.

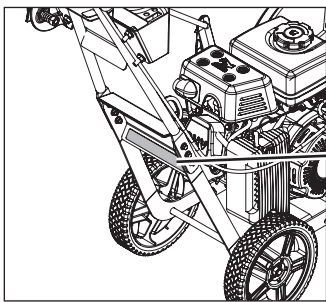

25464
DECAL EDGER PICTORIAL SAFETY

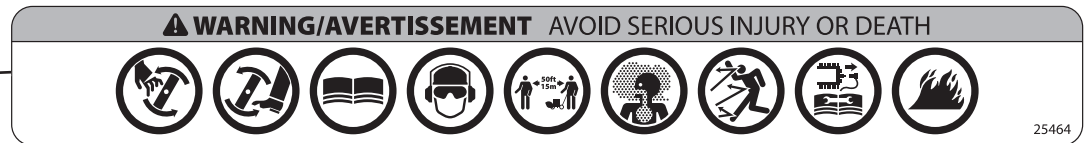

26770
DECAL EDGER BLADE SHIELD

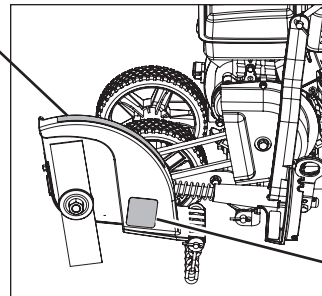

24940
DECAL DANGER KEEP HANDS FEET AWAY

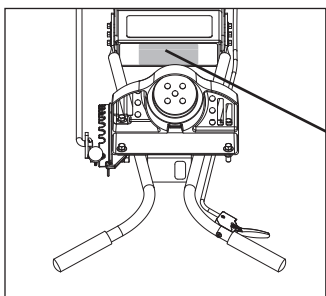

25631
DECAL CAUTION



FEATURES & CONTROLS

Control Functions

The information below briefly describes the function of individual controls. Operating requires the combined use of several controls applied in specific sequences. To learn what combination and sequence of controls to use for various tasks see the OPERATION section.

*For engine features and controls see engine manual.

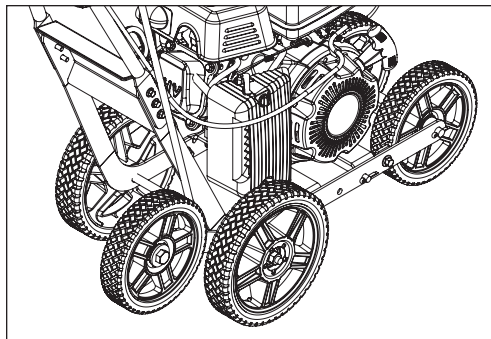
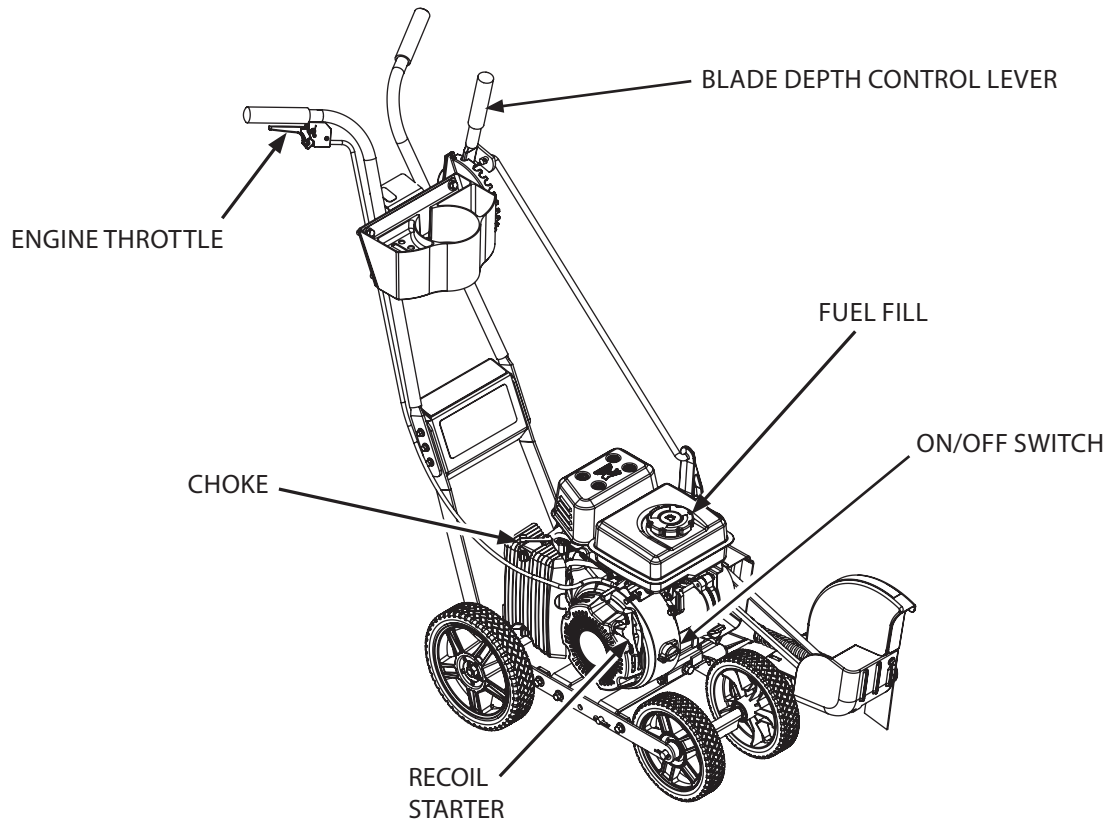

CURB WHEEL (24000 ONLY)

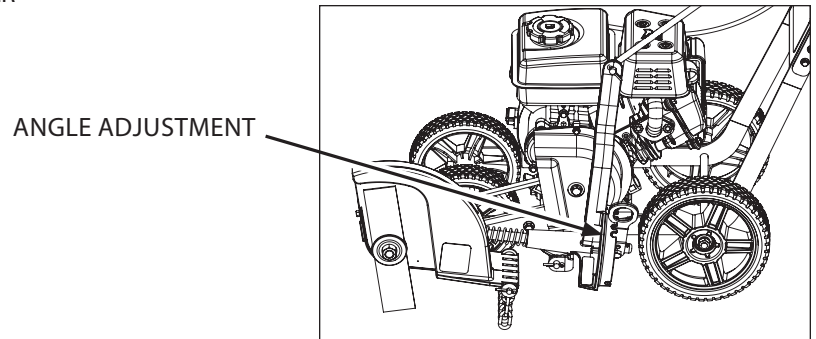

ANGLE ADJUSTMENT

Engine Throttle: Located on the right side handle, as engine throttle is depressed against the handle the engine speed will increase and start the edger blade. When engine throttle is released the engine will go back to idle and blade will stop turning.

Blade Depth Control Lever: The blade depth control lever is located on the left side of the upper handle. It is used to control the depth of the cut. The further forward the blade depth control lever is moved, the deeper into the soil the edger blade will cut.

Recoil Starter: The recoil starter is used to start the engine.

Curb Wheel (Optional): The Curb Wheel Kit offers on the go height adjustment.

SPECIFICATIONS

ENGINE BRAND	VIPER®
ENGINE DISP, TYPE	79CC, 4-CYCLE
ENGINE RATING	3.5 FT-LB MAX TORQUE
FUEL CAPACITY	0.53 GAL
CUP & TOOL HOLDER	INCLUDED
CUTTING DEPTH	2.5 IN
BLADE LENGTH	9 IN
ADJUSTABLE CUTTING DEPTH	YES
ASSEMBLY REQUIRED	YES
TOOL & CUP HOLDER	YES
TRIM MODE	YES
CENTRIFUGAL CLUTCH	YES
BALL BEARING WHEELS	YES
CA (CARB) COMPLIANT (50 STATE)	CARB COMPLIANT
TIRE DIAMETER	8 IN REAR, 7 IN FRONT
TIRE WIDTH	1.5 IN
TIRE MATERIAL	PVC
WHEEL TYPE	NEVER FLAT
NET WEIGHT	57 LBS (BASE), 61.25 LBS (CURB)
GROSS WEIGHT	63.75 LBS (BASE), 68 LBS (CURB)
ASSEMBLED DIMENSIONS	38.7" x 19.3" x 37.7"
BOXED DIMENSIONS (IN)	30.2" x 15.3" x 21.3"
START TYPE	RECOIL (MANUAL)
MANUFACTURER WARRANTY	5 YEAR LIMITED PRODUCT
MANUFACTURER ENGINE WARRANTY	5 YEAR LIMITED ENGINE, 2 YEAR EMISSIONS

NOTE: Specifications are correct at time of printing and are subject to change without notice.

ACCESSORIES

Accessories are available from your authorized *Earthquake®* dealer or directly from *Earthquake*. Always use genuine *Earthquake* accessories.

OPTIONAL ACCESSORIES

CURB WHEEL KIT Part No.24024

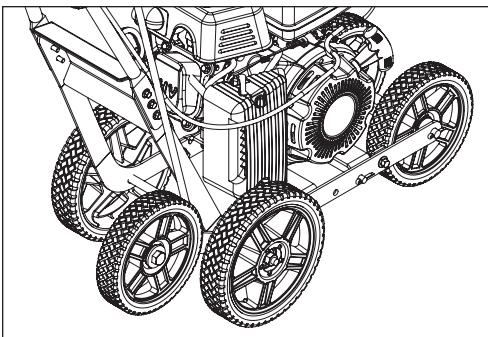

ASSEMBLY

UNPACKING

1. Set aside the operator's manual and parts bag. Carefully lift the top foam out of the box, remove all loose parts from both the top and bottom foam packaging.
2. Parts Bag Content

KEY	DESCRIPTION	23275 QTY.	24000 QTY.
1	BOLT M8 X 25 HEX FLANGE	3	3
2	BOLT M8 X 30 HEX FLANGE	1	1
3	BOLT M6 X 20 HEX FLANGE	6	6
4	BOLT M8 X 20 HEX FLANGE	1	1
5	NUT M8 HEX SERRATED FLANGE	5	5
6	NUT M6 NYLOCK FLANGE	6	6
7	NUT M10 NYLOCK	2	2
8	COTTER PIN 4 MM	6	8
9	AXLE SPACER	4	2
10	WHEEL POSITION SPACER	1	1
11	S BRACKET	1	1
12	WASHER M12	0	3
13	CUP HOLDER STRAP	1	1

Note: Ensure that all parts have been removed from inside and underside slots of foam packaging.



IMPORTANT

ENSURE BLADE DOES NOT TURN WHEN LEVER IS IN TOP NOTCH (DISENGAGED) BY SLOWLY PULLING ENGINE RECOIL AND OBSERVING THAT THE BLADE DOES NOT ROTATE.

ASSEMBLY INSTRUCTIONS

1. Attach handlebars and dash panel with 6xM6x20 bolts. **SEE FIGURE 1.**
2. Attach tool holder and adjustment handle(s) with 3xM8x25 bolts and 1xM8x30 bolt. **FOR MODEL 23275 SEE FIGURE 2a. FOR MODEL 24000 SEE FIGURE 2b.**
3. Add oil to unit. **REFER TO ENGINE MANUAL.**
4. Align cutting head assembly and insert pivot rod as shown in **FIGURE 3.**
5. Connect engine belt to front pulley of cutting assembly.
6. Attach S-bracket to assembly/pivot rod location using cotter key and M8x20 bolt. **SEE FIGURE 3.**
7. Place height adjustment lever into top position.
8. Attach control rod to height adjustment handle and cutting head assembly with cotter keys. **SEE FIGURE 4.**
9. Attach wheels. **SEE FIGURE 5.**

(Optional) ASSEMBLY INSTRUCTIONS

1. Attach curb wheel as shown (for Model 24000 only). **SEE FIGURE 2b & 6.**

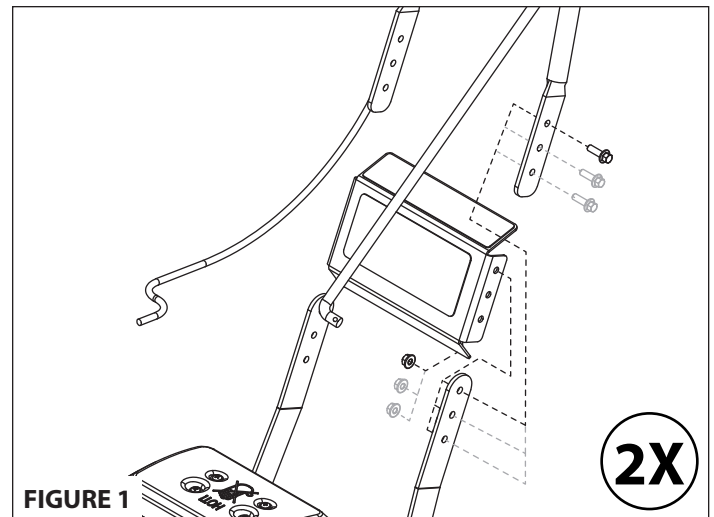

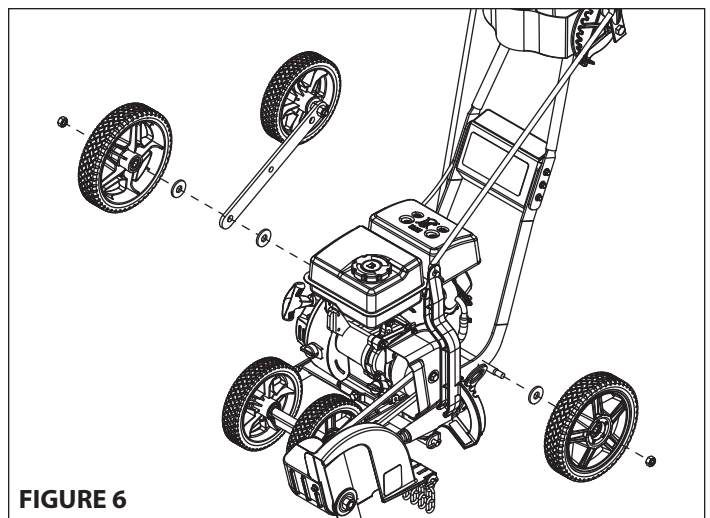
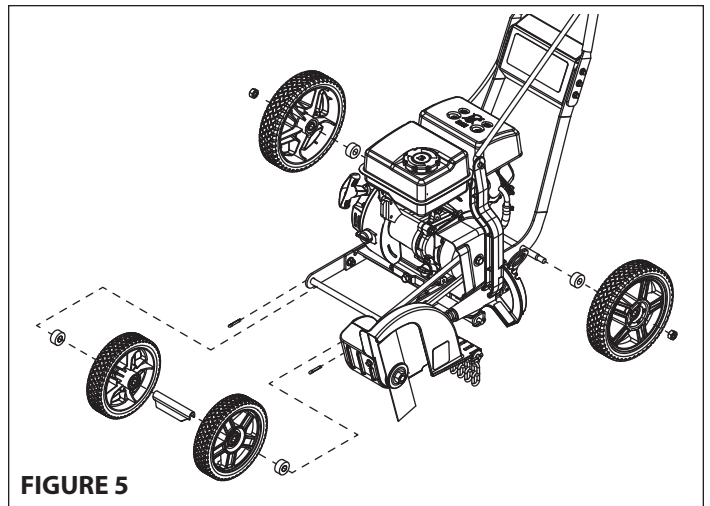
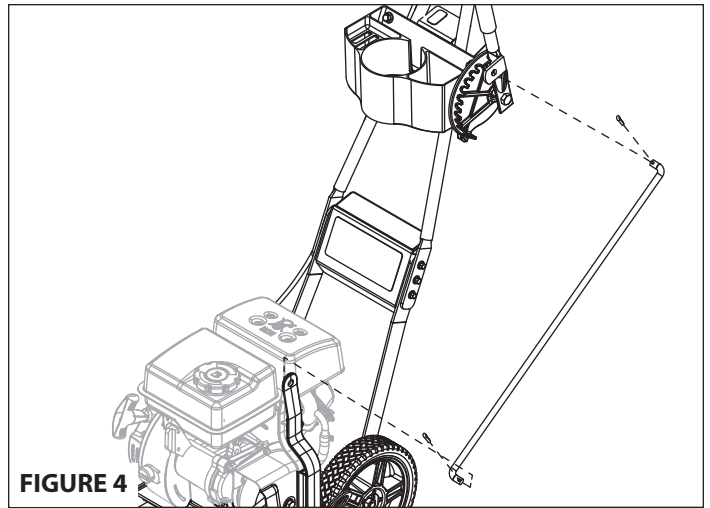
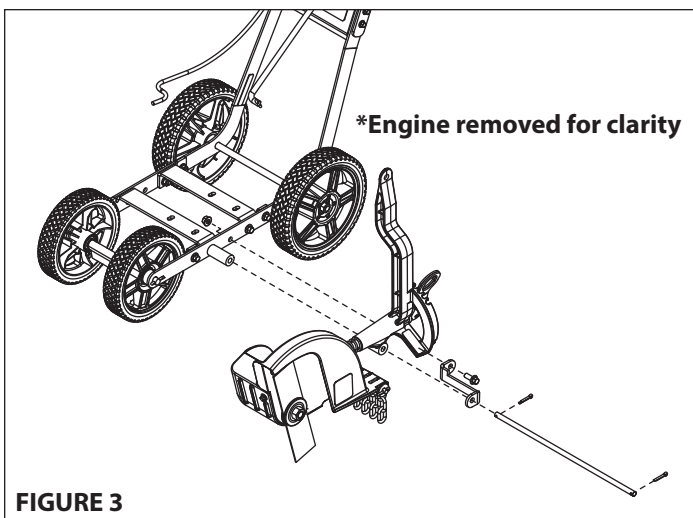
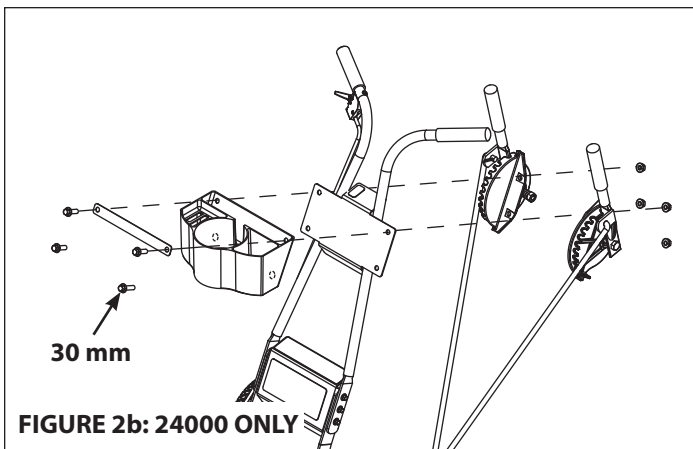
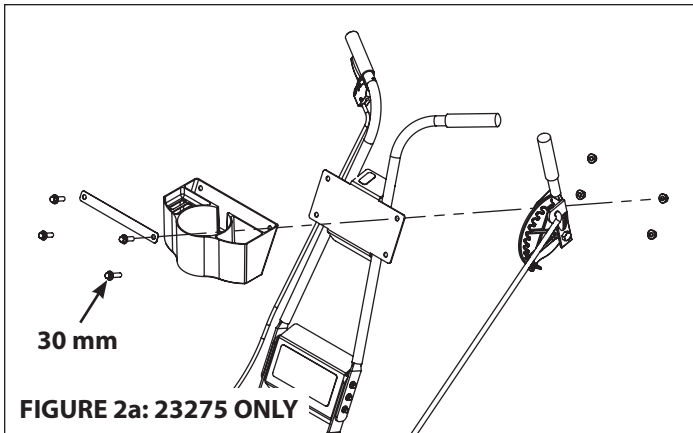

GENERAL OPERATION

WARNING

CARBON MONOXIDE GAS IS TOXIC. MOVE THE ENGINE TO A WELL-VENTILATED AREA OUTDOORS, TO PREVENT CARBON MONOXIDE POISONING. INHALATION CAN CAUSE UNCONSCIOUSNESS AND DEATH.

NEVER LEAVE THE ENGINE RUNNING WHILE UNATTENDED. TURN ENGINE OFF AFTER USE.

MOVE ENGINE TO A WELL-VENTILATED AREA, ALWAYS OUTDOORS, TO PREVENT CARBON MONOXIDE POISONING.

MOVE TO AN AREA AWAY FROM FLAMES OR SPARKS, TO AVOID IGNITION OF VAPORS IF PRESENT.

CAUTION

DO NOT STOP ENGINE BY MOVING CHOKE CONTROL TO CHOKE. BACKFIRE OR ENGINE DAMAGE MAY OCCUR

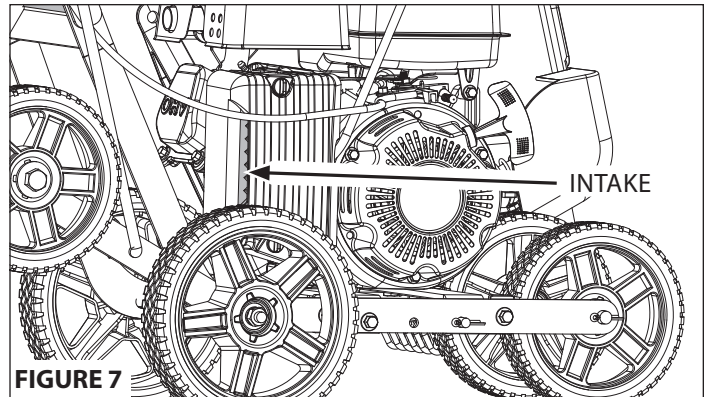

STARTING AND STOPPING THE ENGINE

Note: Operating engine on a steep angle will cause the engine to lose lubrication and seize. SEE SLOPE GUIDE ON PAGE 14

Review "safety and warning precautions" and "pre-operation inspection" sections before starting engine.

Note: Fill with fuel and check oil.

Engine Start

1. Remove all debris from intake and cooling fins to ensure proper air flow. **SEE FIGURE 7**
2. Move the choke lever as follows:
 - If the engine is cold or the ambient temperature is low, move choke lever to the **FULL CHOKE** position. **SEE FIGURE 8**
 - If the engine is warm or the ambient temperature is high, move choke lever to the **HALF CHOKE** position or **RUN** position. **SEE FIGURES 9 AND 10**

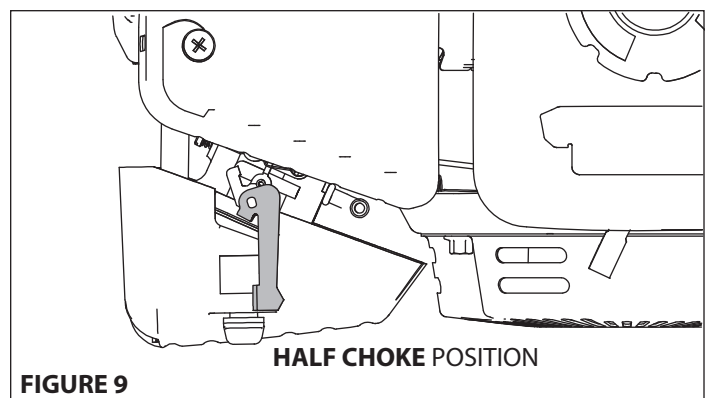
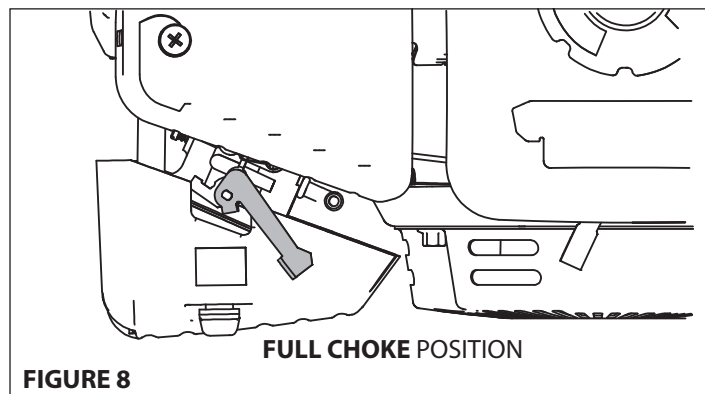

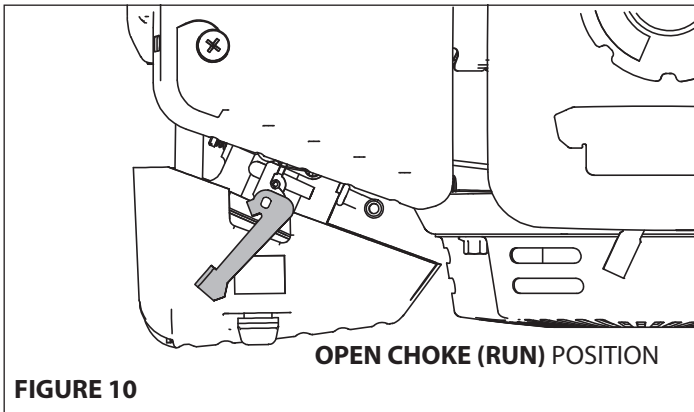

FIGURE 10

4. Turn the On/Off switch to the **ON** position. **SEE FIGURE 11**
5. Grasp starter handle and pull out slowly, until resistance is felt. Without letting it retract, pull rope with a rapid stroke. **DO NOT** pull out the rope all of the way. Let it return to its original position very slowly. Repeat this step until engine starts.
6. After engine begins operating, move the choke lever to **HALF CHOKE**. **SEE FIGURE 9.**
7. Run engine for 5 to 10 seconds at "Half Choke" position until engine warms up.
8. After starting engine slowly move the choke lever to **RUN** position. **SEE FIGURE 10**

To Stop the Engine:

1. Move ON/OFF switch to OFF position. **SEE FIGURE 12.**
2. Pull the starter handle slowly and return the handle to its original position when resistance is felt. This operation will prevent outside moisture from entering the combustion chamber.

CAUTION

IF ENGINE FAILS TO START AFTER ATTEMPTING STARTING PROCEDURES, PLEASE CONTACT OUR CUSTOMER SERVICE DEPARTMENT AT 800-345-6007.

STARTER ROPE CAN CAUSE AN UNANTICIPATED JERK TOWARDS ENGINE. PLEASE FOLLOW INSTRUCTIONS TO AVOID INJURY.

NEVER LEAVE ENGINE RUNNING WHILE UNATTENDED. TURN OFF AFTER EVERY USE.

NEVER CARRY THE MACHINE FROM ONE LOCATION TO ANOTHER WHILE THE ENGINE IS RUNNING.

ALWAYS WEAR A PROTECTIVE HEARING DEVICE.

DO NOT START ENGINE IF FUEL IS SPILLED. WIPE OFF EXCESS FUEL AND ALLOW TO DRY.

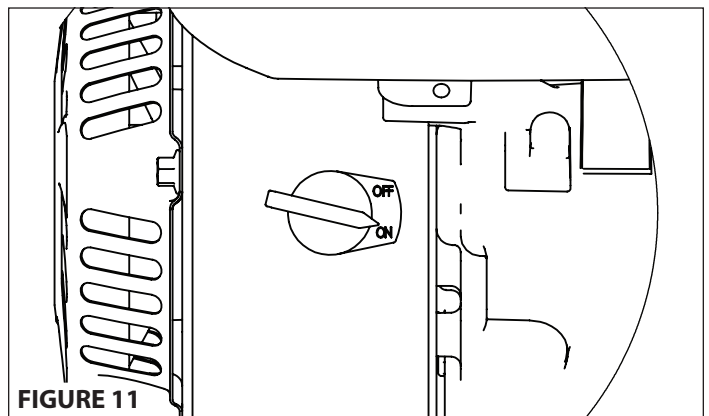

FIGURE 11

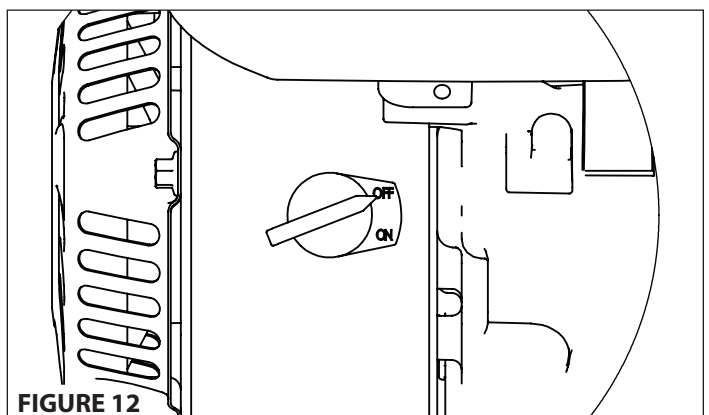

FIGURE 12

EDGING TIPS

1. Move edger to a desired area to begin edging, making sure that the left rear wheel is on a hard surface and the blade is over area to be cut.
2. Lower blade control lever to achieve depth of cut desired. The further the forward blade depth control lever is moved, the deeper or lower the blade will cut into the ground.
3. For newly edged lawns, multiple passes may be needed to achieve desired depth by lowering depth of cut incrementally.
4. For best results, proceed slowly along the path being edged. Slowly moving edger forward and backward through cutting area, making sure to keep the left rear wheel on the hard surface and the blade in the cutting path, close to but not touching the edge of the hard surface.
5. Once you have finished edging selected area, raise the blade control lever back in to the TOP position, move to the next area to be edged, and proceed again from step 1.

WARNING!

ROTATING CUTTING BLADE MAY THROW OBJECTS CAUSING PERSONAL INJURY. KEEP AREA CLEAR OF BYSTANDERS AND DO NOT OPERATE WITHOUT GUARDS IN PLACE.

WARNING!

DO NOT LOWER BLADE IF BLADE IS OVER CONCRETE, ASPHALT, ROCKS OR THE LIKE. BLADE CAN STRIKE SUPPORTING SURFACE, RESULTING IN PERSONAL INJURY OR PROPERTY DAMAGE.

SLOPE GUIDE

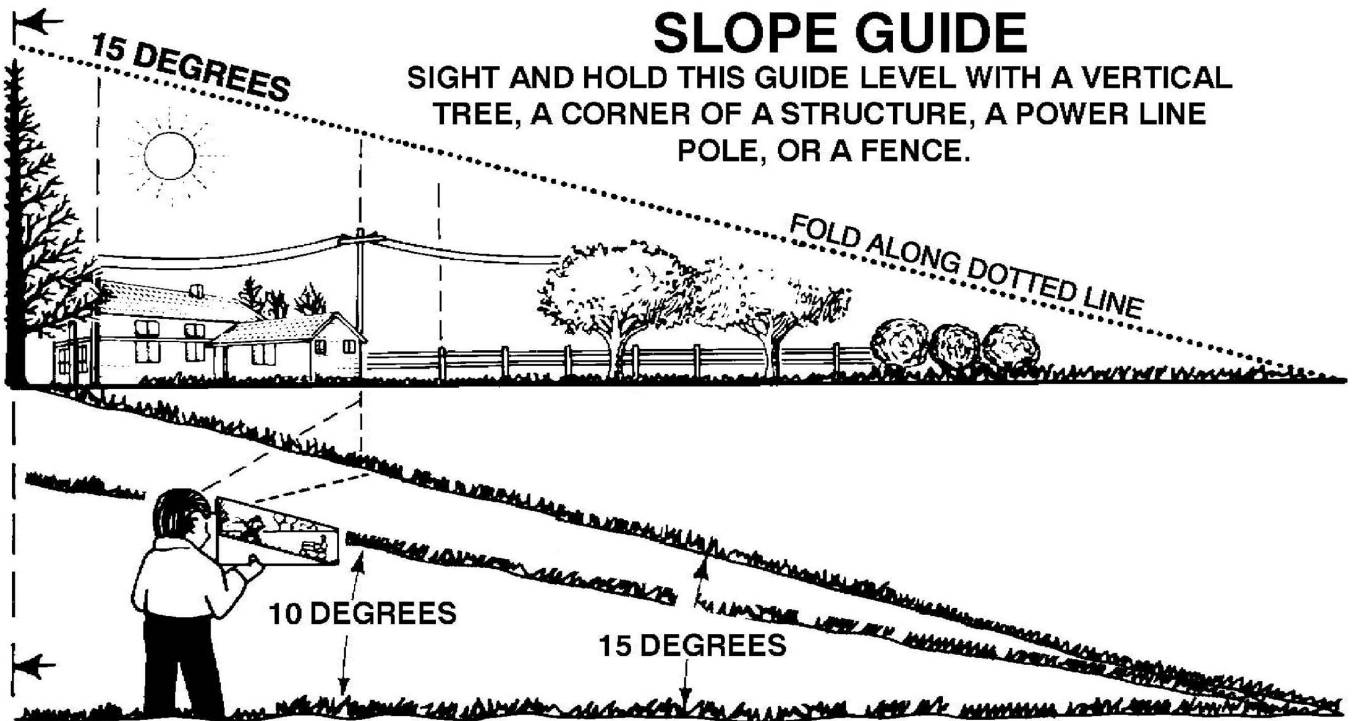

Use this guide to determine slope angle. **Do Not edge on a slope greater than 15 degrees.**

- A 10 degree slope is a hill that increases in height at approximately 1.76 feet (53.6 CM) in 10 feet (304.5 CM).
- A 15 degree slope is a hill that increases in height at approximately 2.68 feet (81.7 cm) in 10 feet (304.5 cm).

WARNING

USE EXTREME CARE AT ALL TIMES AND AVOID SUDDEN TURNS OR MANEUVERS. FOLLOW OTHER INSTRUCTIONS IN THIS MANUAL FOR SAFETY IN EDGING ON SLOPES. USE EXTRA CARE WHEN OPERATING ON OR NEAR SLOPES AND OBSTRUCTIONS.

MAINTENANCE

ENGINE MAINTENANCE

Refer to the Engine Operator's Manual included with your edger for a detailed description of all engine-related service specifications.

REPLACING DAMAGED OR WORN BLADE:

CAUTION

SHARP EDGES OF EDGE-TRIMMER BLADE CAN CUT YOU DURING BLADE MAINTENANCE OR ADJUSTMENT. USE SUITABLE COVERING OVER CUTTING EDGES OF BLADE TO PREVENT BODILY HARM.

1. Turn off the engine switch.
2. Disconnect the spark plug wire from the spark plug and set it aside.
3. Loosen the nut holding blade in place. Remove the nut and clamp washer. **See Figure 14.**
4. Replace blade with a new blade and secure it with a clamp washer and nut.
5. Reconnect the spark plug wire.

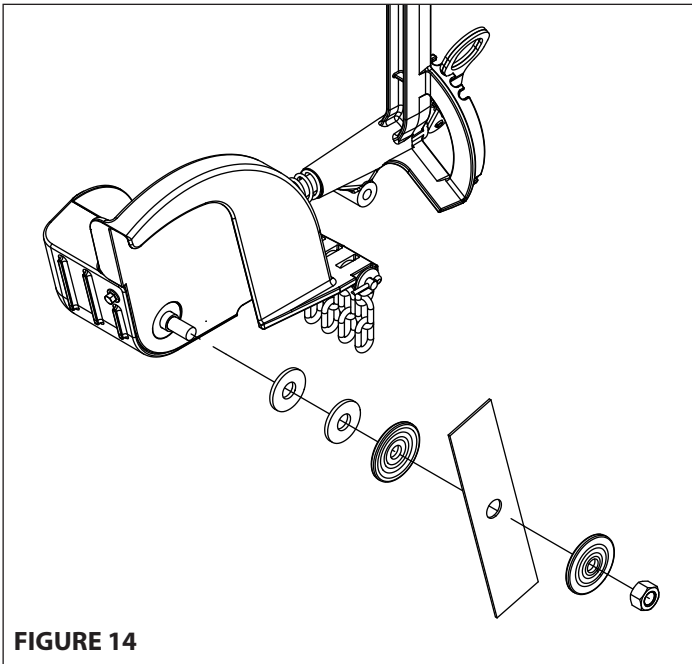

FIGURE 14

LUBRICATION

WHEELS

Lubricate the wheels and bearings at least once a season with a light oil. Also if the wheels are removed for any reason, lubricate the surface of the axle bolt and the inner surface of the wheel with light oil.

PIVOT POINTS

Lubricate the pivot points on the blade depth control lever and, if applicable, the curb height adjustment lever with light oil at least once a season.

WARNING

IMPROPER MAINTENANCE, OR FAILURE TO CORRECT A PROBLEM BEFORE OPERATION CAN CAUSE A MALFUNCTION. ALWAYS FOLLOW THE INSPECTION AND MAINTENANCE RECOMMENDATIONS AND SCHEDULES INCLUDED WITH THIS OPERATOR'S MANUAL.

CHECK ENGINE REGULARLY FOR LOOSE NUTS AND BOLTS. KEEP THESE ITEMS TIGHTENED.

TEMPERATURE OF MUFFLER AND NEARBY AREAS MAY EXCEED 150° F (65° C). AVOID THESE AREAS.

PREVENT ACCIDENTAL STARTING:

- **ENGINE MUST BE TURNED OFF AND COOL.**
- **SPARK PLUG WIRE MUST BE REMOVED FROM SPARK PLUG BEFORE CHECKING AND ADJUSTING ENGINE OR EQUIPMENT.**

FAILURE TO FOLLOW THESE WARNINGS CAN RESULT IN SERIOUS INJURY OR DEATH.

TRANSPORTING AND STORAGE

1. If fuel is present in the fuel tank, transport in an open vehicle in an upright position.
2. If an enclosed vehicle must be used, remove fuel into an approved red fuel container. DO NOT siphon by mouth.
3. Wipe away any spilled fuel from engine and edger. Allow to dry.

LONG-TERM STORAGE (30 DAYS OR MORE WITHOUT USE)

If your edger will not be used for more than one month, prepare it for long term storage.

STEPS FOR LONG-TERM STORAGE

1. Add fuel stabilizer according to manufacturer's instructions.
2. Run engine for 10-15 minutes to ensure that the stabilizer reaches the carburetor.
3. Remove the remainder of the fuel from the gas tank into an approved fuel container.
4. Remove all debris from the edger engine and blade guard area.



CAUTION

TO AVOID INJURY OR DEATH, NEVER SIPHON FUEL BY MOUTH.

NEVER STORE ENGINE WITH FUEL IN THE TANK INSIDE A BUILDING. POTENTIAL SPARKS MAY BE PRESENT FOR IGNITION OF FUEL AND FUEL VAPORS.

TROUBLESHOOTING

At *Earthquake®*, we build quality and durability into the design of our products; but no amount of careful design by us, and careful maintenance by you, can guarantee a repair-free life for your *Earthquake®* Edger. Most repairs will be minor, and easily fixed by following the suggestions in the troubleshooting guide in this section.

The troubleshooting guide will help you pinpoint the causes of common problems and identify remedies.

For more complicated repairs, you may want to rely on an authorized service center or Earthquake. Earthquake will make the necessary repairs if a service center is not available. A parts breakdown is located toward the end of this manual.

We will always be glad to answer any questions you have, or help you find suitable assistance. To order parts or inquire about warranty, call or e-mail us using the contact information found in this section.

SPARE PARTS

Only use approved *Earthquake®* service parts.

ORDERING REPLACEMENT PARTS

Parts can be obtained directly from the factory. To order parts visit www.getearthquake.com or call 1-800-345-6007.

For other general questions, you can e-mail us at info@ardisam.com.

Please include the following information with your order:

- 1) Part numbers
- 2) Part description
- 3) Quantity
- 4) Model number and serial number

TROUBLESHOOTING GUIDE

PROBLEM	POSSIBLE CAUSE	REMEDY/ACTION
Engine will not start	1. Power switch off	1. Flip switch to ON position
	2. Spark plug wire disconnected	2. Connect spark plug wire to spark plug
	3. Out of fuel	3. Refuel
	4. Spark plug wet, faulty or improperly gapped	4. Clean, replace or gap spark plug
	5. Stale fuel	6. Drain old fuel and replace with fresh. Use fuel stabilizer as a future preventative measure.
Engine runs rough, floods during operation	1. Dirty air filter	1. Clean or replace air filter
	2. Choke partially engaged	2. Turn off choke
	3. Dirty carburetor	3. Call Customer Service
Engine is hard to start	1. Stale fuel	1. Drain old fuel and replace with fresh. Use fuel stabilizer as a future preventative measure.
	2. Spark plug wire loose	2. Make sure spark wire is securely attached to spark plug
	3. Dirty carburetor	3. Clean carburetor, use fuel stabilizer, new fuel can
Engine misses or lacks power	1. Clogged fuel tank or fuel filter	1. Remove and clean
	2. Clogged air filter	2. Clean or replace
	3. Spark plug wet, faulty or improperly gapped	3. Clean, replace or gap spark plug
	4. Carburetor needle stuck open	4. Clean carburetor
Engine runs, then quits	1. Fuel cap not venting	1. Unclog, or replace fuel cap
Engine revs too high	1. Speed Adjustment Needed	1. Call customer service
Edger blade turns at idle	1. Idle speed too high	1. Adjust idle speed lower
	2. Broken clutch spring	2. Replace clutch
Edger blade fails to turn	1. Jammed, foreign object in blade area	1. Clear obstruction
Edger blade fails to cut properly	1. Blade worn out	1. Replace blade
	2. Blade wobbles	2. Replace clamp washer, tighten nut

Contact a service provider if above remedies fail.

PARTS BREAKDOWN

EDGER TRANSMISSION AND BLADE PARTS EXPLOSION

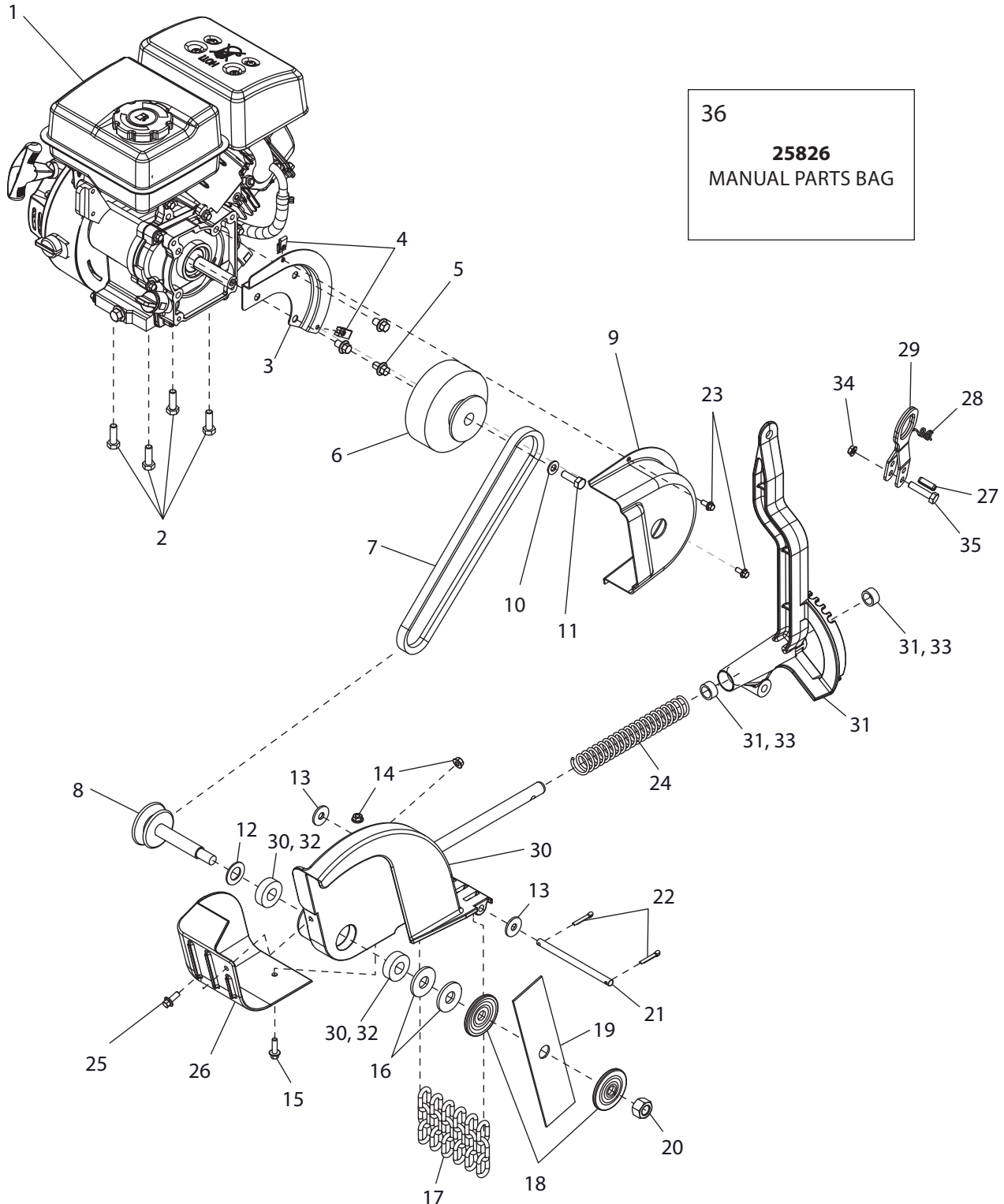

EDGER TRANSMISSION AND BLADE PARTS LIST

KEY	PART #	DESCRIPTION	QTY.
1	25494	ENGINE R80V 79CC EPA III CARB ICES	1
2	24169	BOLT M8 X 25 HEX	4
3	23989	BRACKET CLUTCH SHIELD	1
4	23873	CAGE NUT M5	2
5	4711	BOLT M8 X 12 HEX FLANGE	3
6	23487	CENTRIFUGAL CLUTCH	1
7	24021	BELT 4L310	1
8	24001	PULLEY WELDMENT	1
9	23645	CLUTCH SHIELD	1
10	26439	DRIVE SHAFT CAP M6	1
11	23511	BOLT M6 X 25 HEX	1
12	24148	WAVE WASHER M16	1
13	3245	WASHER M8	2
14	14109	NUT M6 NYLOCK	2
15	25058	BOLT M6 X 22 HEX FLANGE	1
16	24149	WASHER M14	2
17	23265	CHAIN LINK ASSEMBLY	6
18	23263	BLADE CLAMP WASHER	2
19	23262	BLADE EDGER	1
20	W1200129	NUT M14 HEX	1

KEY	PART #	DESCRIPTION	QTY.
21	24836	CHAIN GUARD ROD	1
22	22097	COTTER PIN 4 MM	2
23	400018	BOLT M5 X 12 HEX FLANGE	2
24	23269	SPRING BELT TENSION CUTTING HEAD	1
25	67028	BOLT M6 X 16 HEX FLANGE	1
26	23253	BELT GUARD FRONT	1
27	24170	ROLL PIN M8 X 24	1
28	23270	ANGLE ADJUSTMENT ARM SPRING	1
29	23230	ANGLE ADJUSTMENT HANDLE	1
30	25363	KIT - CUTTING HEAD BLADE SHIELD ASSEMBLY WITH BEARINGS & DECALS	1
31	25722	KIT - HEAD ARM CONTROL	1
32	23244	15.75 ID X 35 OD X 11 BEARING	2
33	23232	15 ID X 20 OD BUSHING	2
34	16400	NUT M8 NYLOCK FLANGE	1
35	26961	BOLT M8 X 35 HEX	1
36	25826	ASSEMBLY MANUAL BAG EDGER	1

EDGER PRODUCT DECALS

24937

DECAL EQ LOGO RECTANGULAR 2



24938

DECAL THROTTLE CONTROL EDGER

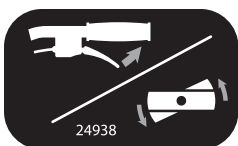

24941

DECAL BLADE ANGLE ADJUST EDGER

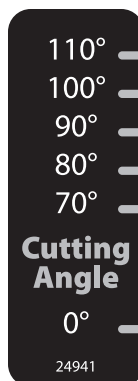

EDGER CHASSIS PARTS EXPLOSION AND LIST

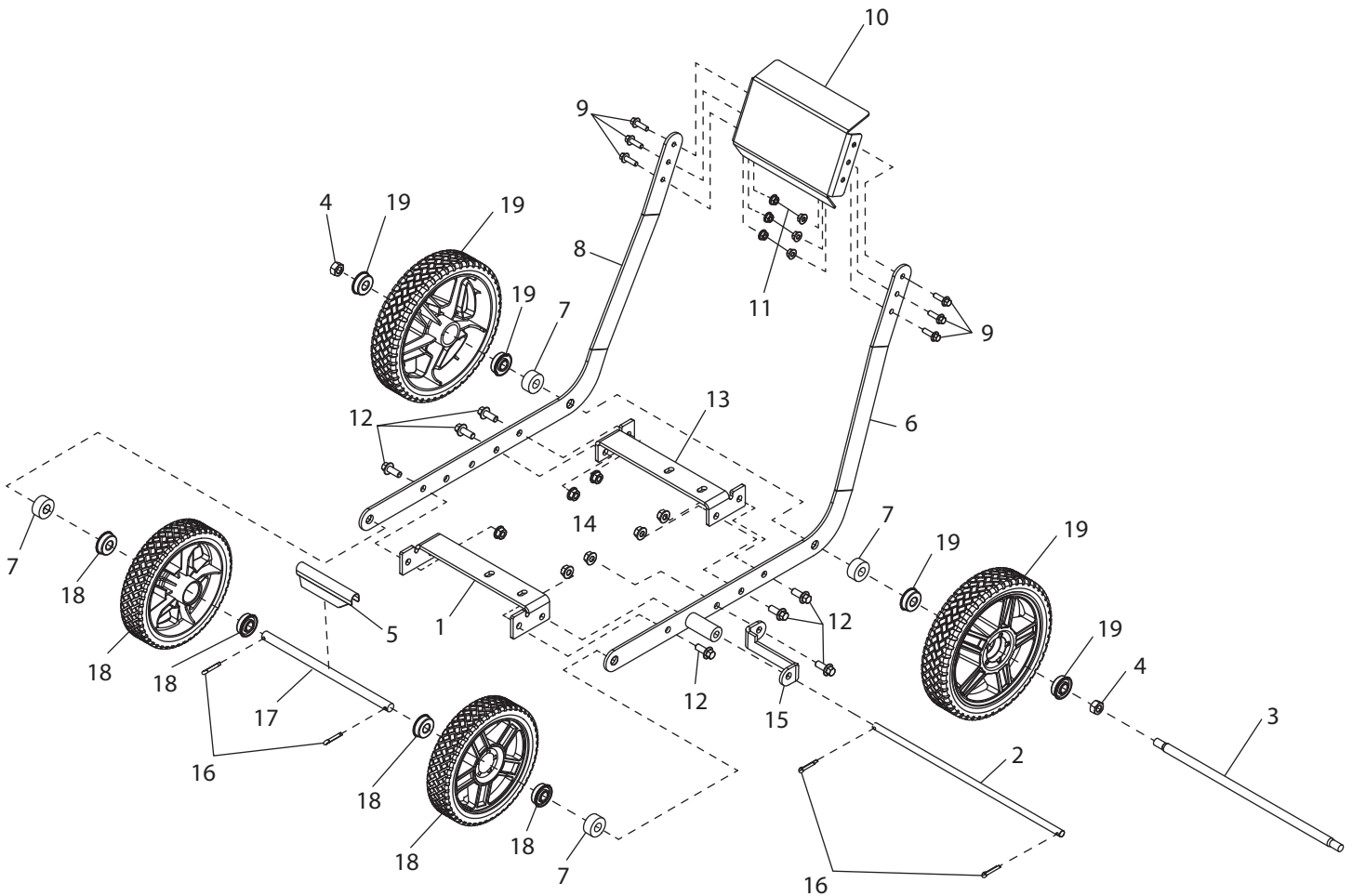

KEY	PART #	DESCRIPTION	QTY.
1	23252	VIPER ENGINE MOUNT FRONT	1
2	23233	PIVOT ROD	1
3	23808	REAR AXLE	1
4	W1265V0903	NUT M10 NYLOCK	2
5	23254	WHEEL POSITION SPACER	1
6	24030	SIDE BAR LEFT	1
7	23266	AXLE SPACER	4
8	23249	SIDE BAR RIGHT	1
9	25058	BOLT M6 X 20 HEX FLANGE	6
10	25580	PANEL DASH WITH DECALS	1

KEY	PART #	DESCRIPTION	QTY.
11	14109	NUT M6 NYLOCK FLANGE	6
12	19945	BOLT M8 X 20 FLANGE	7
13	23251	VIPER ENGINE MOUNT REAR	1
14	16400	NUT M8 HEX NYLOCK FLANGE	7
15	23229	S BRACKET	1
16	22097	COTTER PIN 4 MM	4
17	23239	FRONT AXLE	1
18	23240	KIT - FRONT TIRE WITH BEARINGS	2
19	23234	KIT - REAR TIRE WITH BEARINGS	2

EDGER HANDLEBAR PARTS EXPLOSION AND LIST

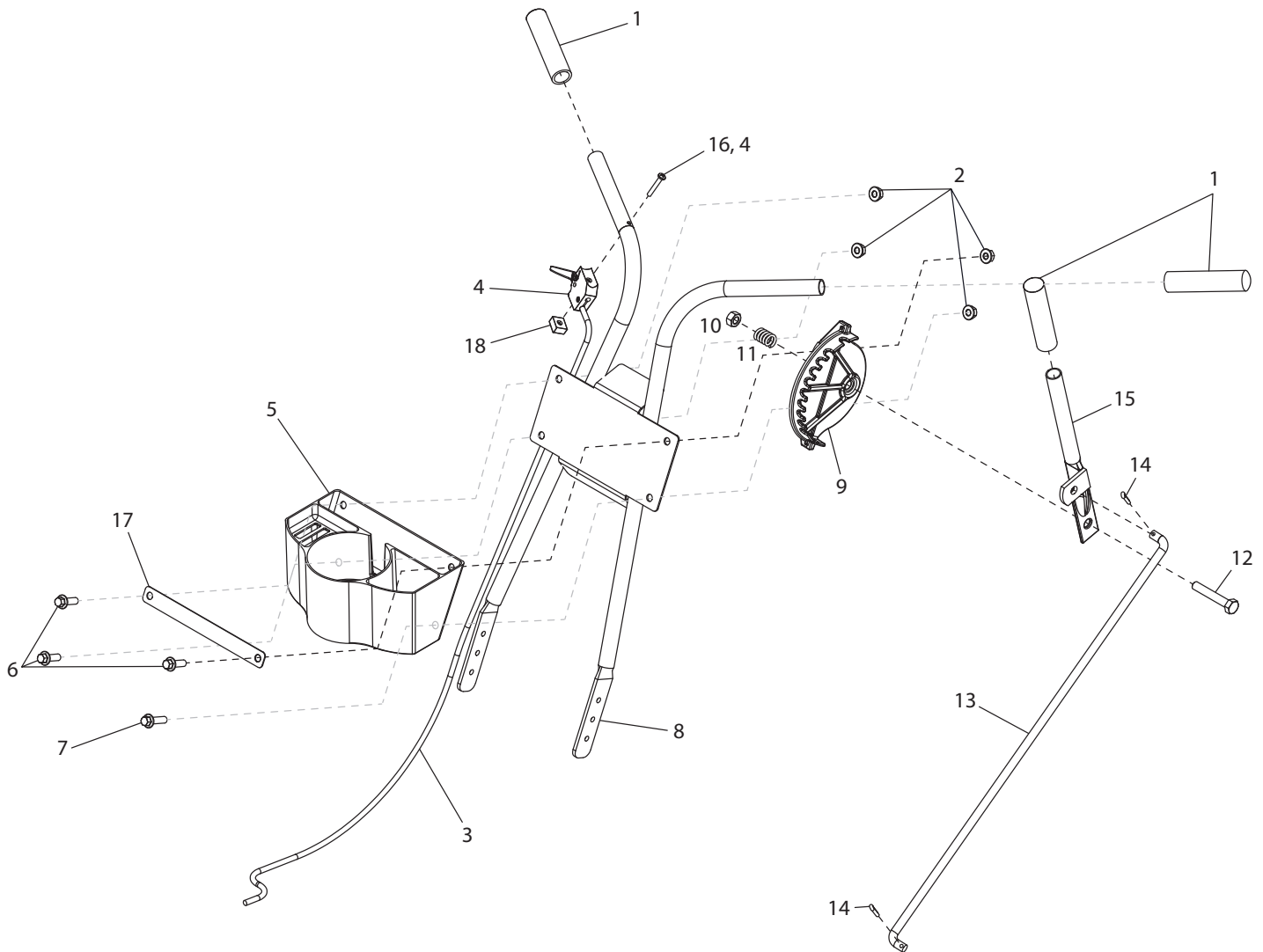

KEY	PART #	DESCRIPTION	QTY.
1	23261	GRIP	3
2	16400	NUT M8 NYLOCK FLANGE	4
3	23245	THROTTLE CABLE	1
4	26771	ASSEMBLY TRIGGER LONG THROW	1
5	24769	CUP AND TOOL HOLDER	1
6	64617	BOLT M8 X 25 HEX FLANGE	3
7	3244	BOLT M8 X 30 HEX FLANGE	1
8	25712	HANDLE BARS WITH DECALS	1
9	23259	BRACKET HEIGHT ADJUSTER	1

KEY	PART #	DESCRIPTION	QTY.
10	W1265V0903	NUT M10 NYLOCK	1
11	23268	SPRING FOR HEIGHT ADJUSTMENT	1
12	18844	BOLT M10 X 20 HEX	1
13	23260	CONTROL ROD	1
14	22097	COTTER PIN 4 MM	2
15	23246	HEIGHT SELECTOR	1
16	10888	BOLT M5 X 30 PHILLIPS	1
17	26930	STRAP TOOL & CUP HOLDER	1
18	17056	NUT M5 SQUARE	1

(OPTIONAL) EDGER CURB WHEEL KIT PARTS EXPLOSION AND LIST (24024)

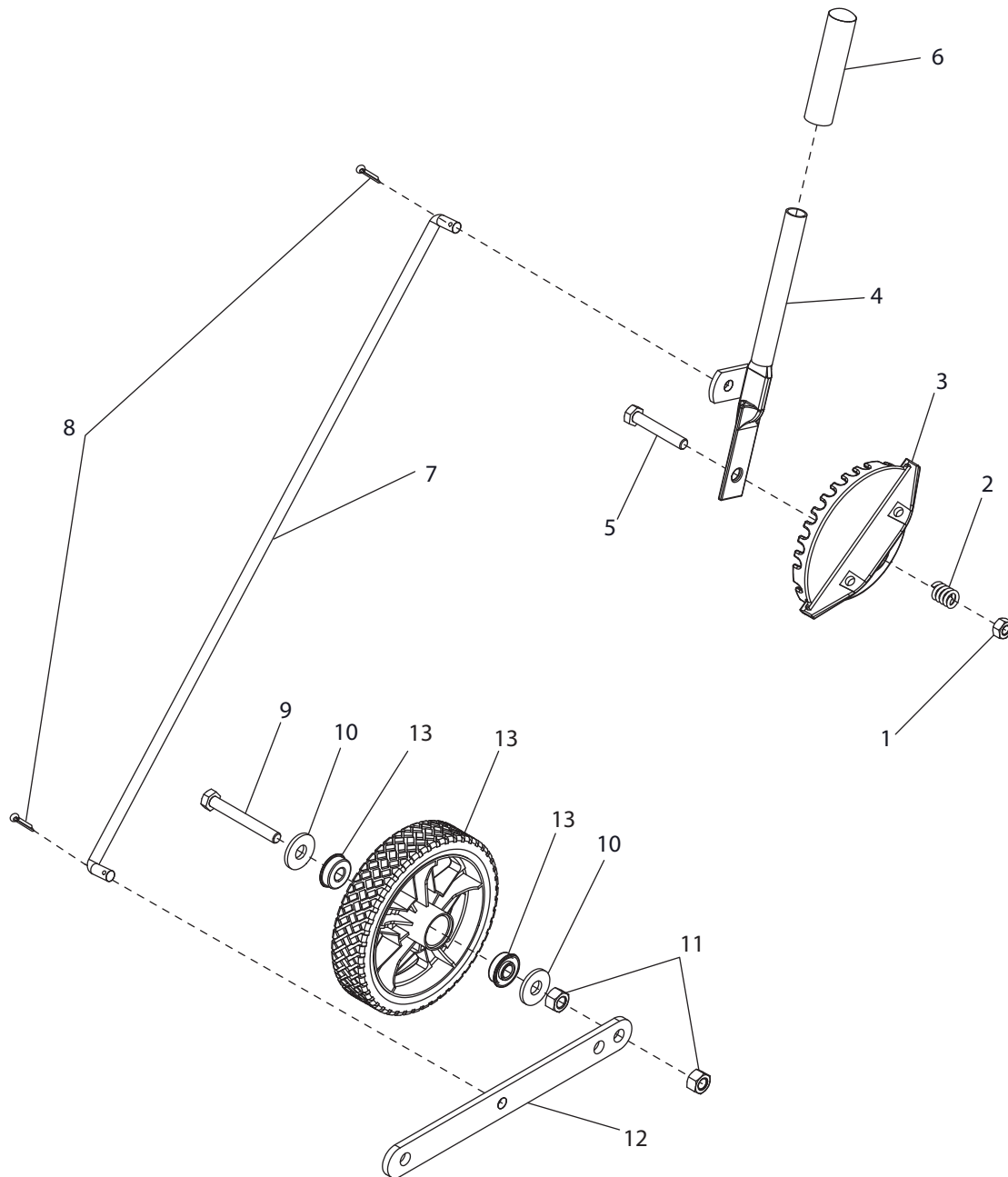

KEY	PART #	DESCRIPTION	QTY.
1	W1265V0903	NUT M10 NYLOCK	1
2	23268	SPRING FOR HEIGHT ADJUST	1
3	23259	BRACKET HEIGHT ADJUSTER	1
4	23985	HANDLE WHEEL HEIGHT SELECTOR	1
5	18844	BOLT M10 X 20 HEX	1
6	23261	GRIP	1
7	23809	CONTROL ROD CURB WHEEL	1

KEY	PART #	DESCRIPTION	QTY.
8	22097	COTTER PIN 4 MM	2
9	25318	BOLT M12 X 80 HEX	1
10	50175	WASHER M12	2
11	25131	NUT M12 X 1.75 HH	2
12	23984	CURB WHEEL LEG	1
13	23240	WHEEL KIT	1



WARRANTY TERMS AND CONDITIONS

Ardisam, Inc. (Ardisam) warrants this edger under a five-year limited warranty to be free from defects in the material or workmanship or both for a period not exceeding sixty consecutive months from the date of original purchase by the first retail consumer or first commercial end user. "Consumer use," means personal recreational use by a retail consumer. "Commercial use," or "commercial application" means all other uses, including use for commercial, income producing or rental purposes. Once a product has experienced commercial use, it shall thereafter be considered as a commercial use product for the purpose of this warranty. This warranty applies to the original owner that provides a proof of purchase. This warranty is not transferable. The warranty period begins on the date of purchase by the first retail consumer or commercial end user, and continues for the sixty month consecutive period thereafter. Any unit used in a commercial application is covered for a period of 90 days after purchase by the first commercial end user. For the warranty to be valid, the product must be registered online within 30 days of purchase, or the warranty card must be filled out and received by Ardisam within 30 days of purchase. Ardisam shall not be obligated for transportation charges that result from repair or replacement under the terms of this warranty. Transportation charges are the sole responsibility of the purchaser.

This warranty excludes parts that are worn or damaged due to normal wear, such as bearings, bushing, wheels, tires, centrifugal clutch, blades, belts, pulleys, cables, routine maintenance items such as O-rings, seals, and lubricants. Negligent use such as using the edger for a purpose other than for which it was designed and manufactured, continued use of edger after sudden change in vibration, using the edger in violation of local codes, ordinances and good trade practices voids this warranty. *These warranties apply only to products which have not been subjected to negligent use, abuse, misuse, overload, improper installation, alteration, accident, acts of God (or other events beyond Ardisam's control) lightning, vandalism, unauthorized parts, or if repairs have been performed at a non-authorized service facility. These warranties shall not cover damage from normal wear and tear, normal maintenance parts and services, or improper installation, operation, storage, or maintenance; nor operating the equipment above recommended maximums as stated in this manual and the accompanying engine manual.

This limited warranty applies to defects in the material or workmanship of the product only. There is no other express warranty. Implied warranties, including those of merchantability and fitness for a particular purpose, are limited to one year from purchase, or to the extent permitted by law. All other implied warranties are excluded. Liability for incidental or consequential damages are excluded to the extent exclusion is permitted by law. Ardisam does not assume, and does not authorize any other person to assume for Ardisam, any liability in connection with the sale of Ardisam products. **To be at "No Charge," warranty work must be sent directly to and performed by Ardisam or an Ardisam Authorized Warranty Service Facility.** To obtain warranty service and/or replacement instructions, contact the Ardisam Customer Service Department at 800-345-6007. If you choose to ship your product to Ardisam for warranty repair, you must first have prior approval from Ardisam by calling the Ardisam Customer Service Department for a return material authorization number (RMA#). Under these circumstances, all items must be shipped prepaid. Ardisam will, in its discretion, at no charge, repair or replace any defective part to which this warranty applies. Ardisam retains the right to change models, specifications and price without notice. Ardisam shall not be obligated to ship any repair or replacement product to any location outside of the United States of America or Canada. Some states and countries do not allow the limitations on how long an implied warranty lasts, or the exclusion or limitation of incidental or consequential damages, so the above limitation may not apply to you. This warranty gives you specific legal rights, and you may also have other rights which vary from state to state and country to country.

SEE ENGINE MANUAL FOR ENGINE WARRANTY



Earthquake®, Division of Ardisam, Inc.

1160 8th Avenue, PO Box 666

Cumberland, WI 54829

800-345-6007 | Fax 715-822-2223

E-mail: info@getearthquake.com

All weights, specifications and features are approximate and are subject to change without notice. Due to continuous product improvements, product images may not be exact. Items used for props not included. Some assembly may be required.

Check for parts online at www.getearthquake.com or call 800-345-6007 M-F 8-5