

Ice-O-Matic[®]

Service Parts Manual GEMU090 Series



GEMU090

Service Parts

This is the illustrated parts list for the GEMU090.

Table of Contents

Door Components	Page 2
Cabinet	Page 3
Storage Bin and Ice Chute	Page 4
Reservoir, Water Sensor and Misc	Page 5
Refrigeration	Page 6
Under Bin Parts	Page 7
Ice Making Section	Page 8
Control System	Page 9
Wiring Diagram	Page 10
Schematic Diagram	Page 11

Service Parts

Door Components

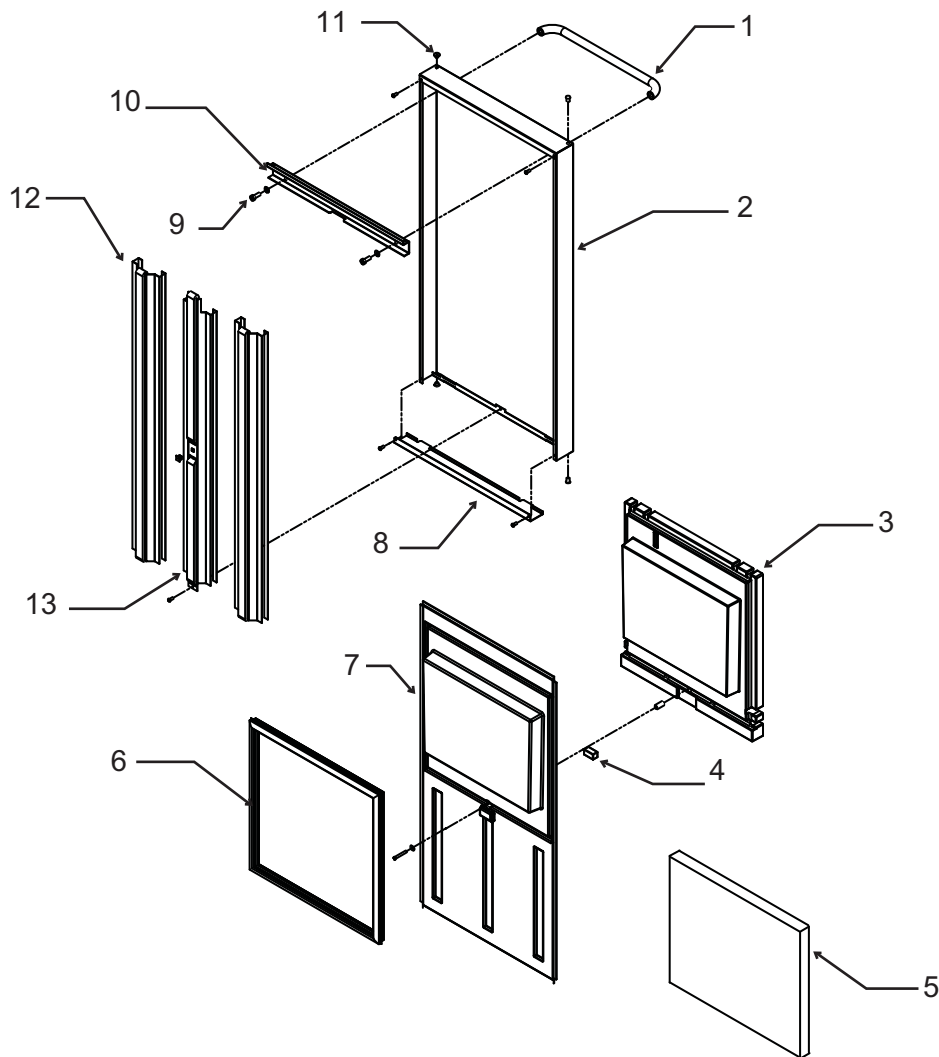

Item Number	Part Number	Description
1	1011448-01	Handle, door
2	1011448-02	Door panel
3	1011448-03	Insulation, upper
4	1011448-04	Magnet, door
5	1011448-05	Insulation, lower
6	1011448-06	Door gasket
7	1011448-07	Liner, door
8	1011448-08	Door bottom
9	1011448-09	Screw, handle
10	1011448-10	Bracket, door handle
11	1011448-11	Bushing, door hinge, same on bottom
12	1011447-12	Door support
13	1011448-13	Door support, center
14	1011448-14	Complete door, assembled. Includes all above parts

Service Parts

Cabinet

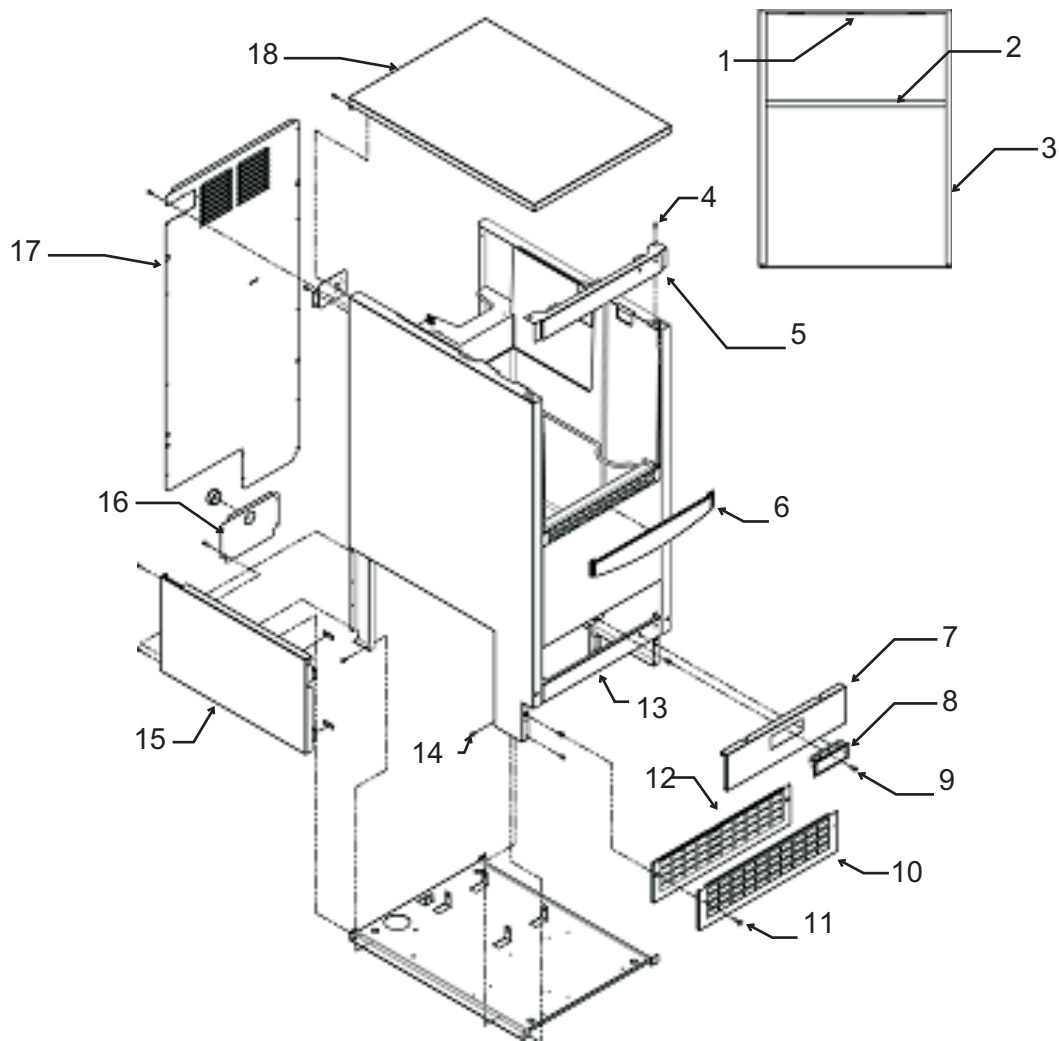

Item Number	Part Number	Description
1	1011448-15	Gasket, top panel
2	1011448-16	Gasket, top panel
3	1011448-17	Gasket, top panel
4	1011448-18	Screw
5	1011448-111	Top hinge bracket
6	1011448-21	Inlay
7	1011448-22	Front service panel
8	1011448-23	Handle
9	1011448-24	Screw
10	1011448-25	Kick plate cover
11	1011448-26	Screw
12	1011448-27	Kick plate
13	1011448-112	Bottom hinge bracket
14	9031046-27	Screw
15	1011448-30	Side service panel
16	1011448-31	Drain panel
17	1011448-32	Back panel
18	1011448-33	Top panel only
18a	1011448-34	Insulation, top panel Not Illustrated
19	1011448-113	Hinge, right top
20	1011448-114	Hinge, right bottom
21	1011351-43	Screw Receptacle Not Shown

Service Parts

Storage Bin and Ice Chute

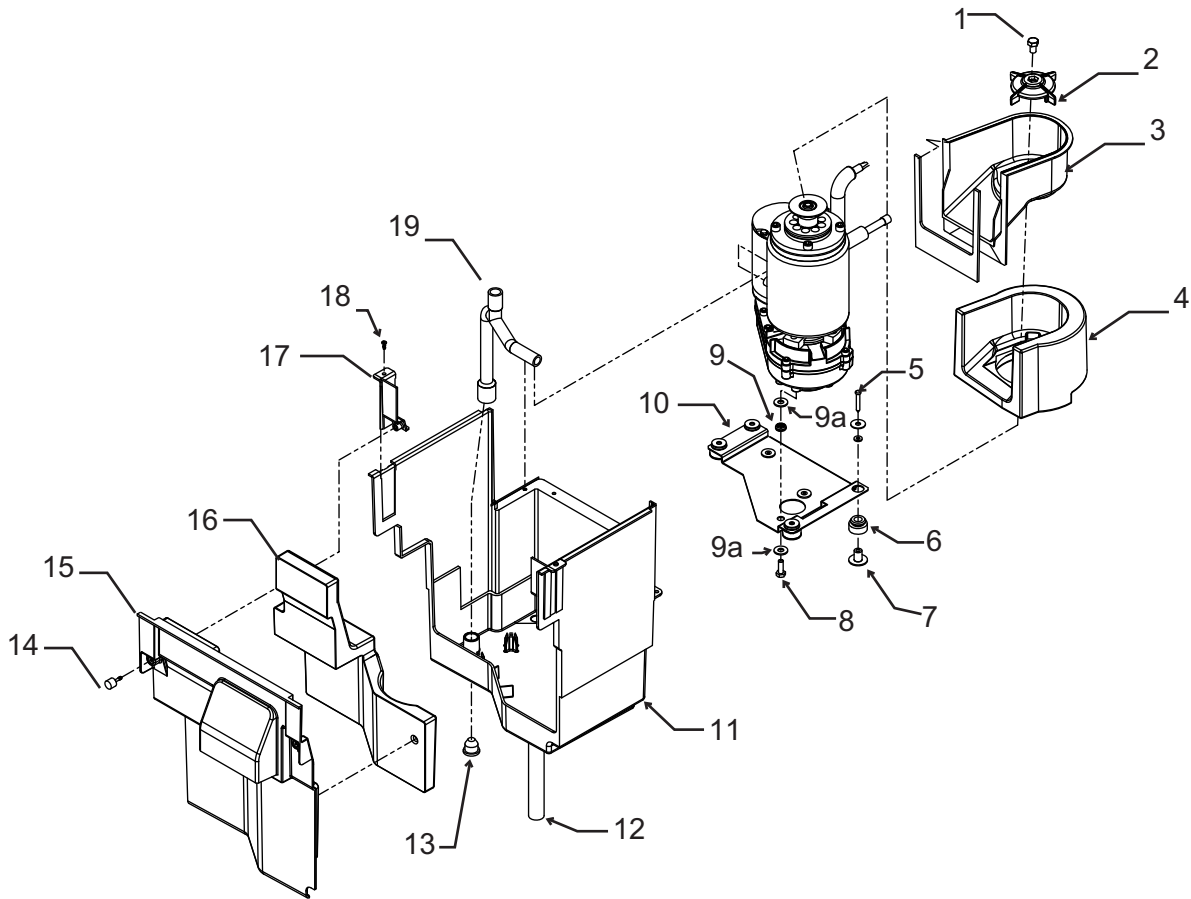

Item Number	Part Number	Description
1	1011448-35	Screw, 5/16-18
2	1011448-36	Ice sweep
3	1011448-37	Chute
4		Chute insulation, part of item 3
5	1011448-38	Screw
6	1011448-39	Grommet
7	1011448-40	Flanged bushing
8	1011448-41	Cap screw
9	1011448-42	Vibration grommet
9a	1011448-43	Washer
10	1011448-44	Mounting plate only
11	9051610-01	Shelf, gear and evap asy
12	1011448-45	Drain
13	1011448-46	Drain plug
14	1011448-47	Thumb screw
15	1011448-48	Cover
16		Cover insulation, part of item 15
17	1011448-49	Support bracket, left
	1011448-50	Support bracket, right
18	1011448-18	Screw
19	1411448-51	Tube, reservoir to evap

Service Parts

Reservoir, Water Sensor and Misc

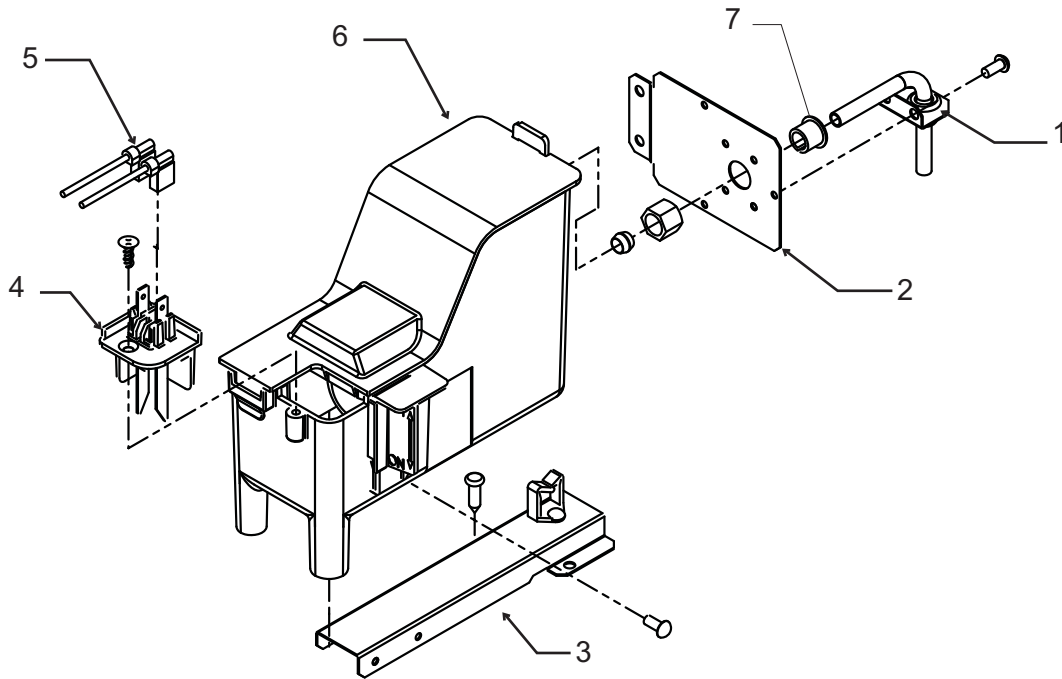

Item Number	Part Number	Description
1	1011448-52	Brace
2	1011148-53	Bracket
3	1011448-54	Reservoir mounting bracket
4	1011448-55	Water level sensor
5	1011448-56	Water sensor harness
6	1011448-57	Reservoir w/valve and cover
	1011448-116	Float valve only

Misc:

1011448-59 12 pack of Pre-Mixed Squirt Bottle of Clear 1 scale remover

Service Parts

Refrigeration

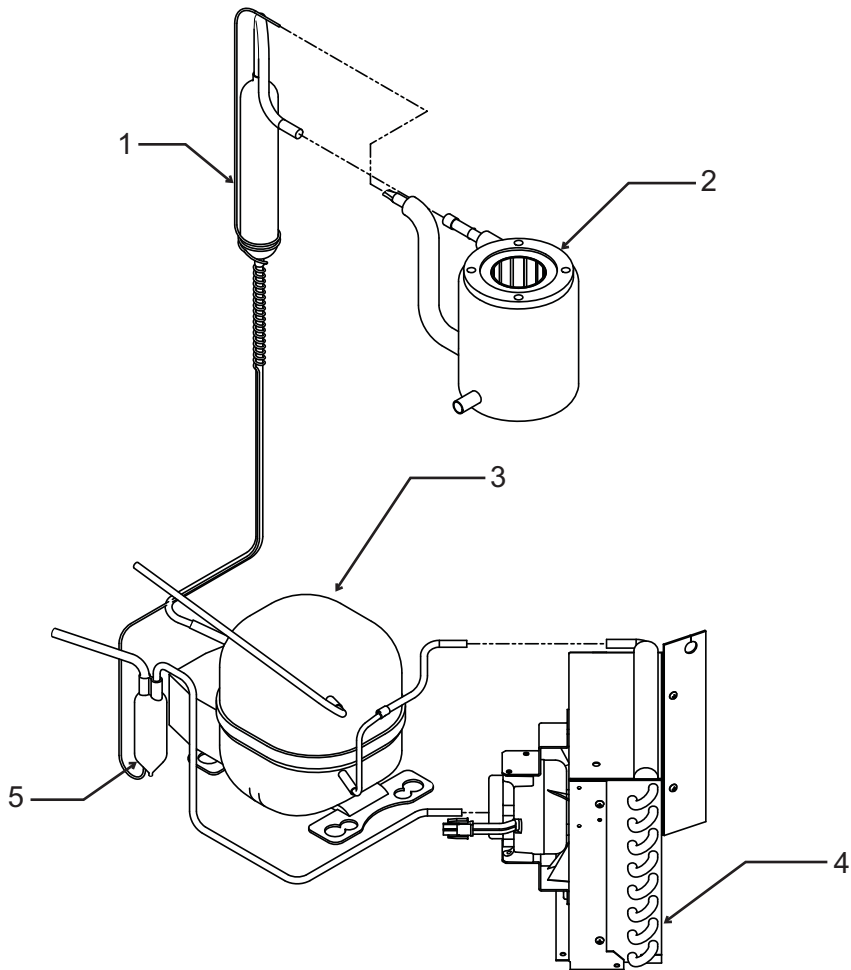

Item Number	Part Number	Description
1	1011448-61	Suction line w/cap tube
2	1011448-62	Evaporator
3	1011448-63	Compressor
Compressor includes overload, relay and drier		
3a	1011448-64	Overload
3b	1011448-65	Relay
4	1011448-66	Condenser
5	1011448-115	Dryer

Service Parts

Under Bin Parts

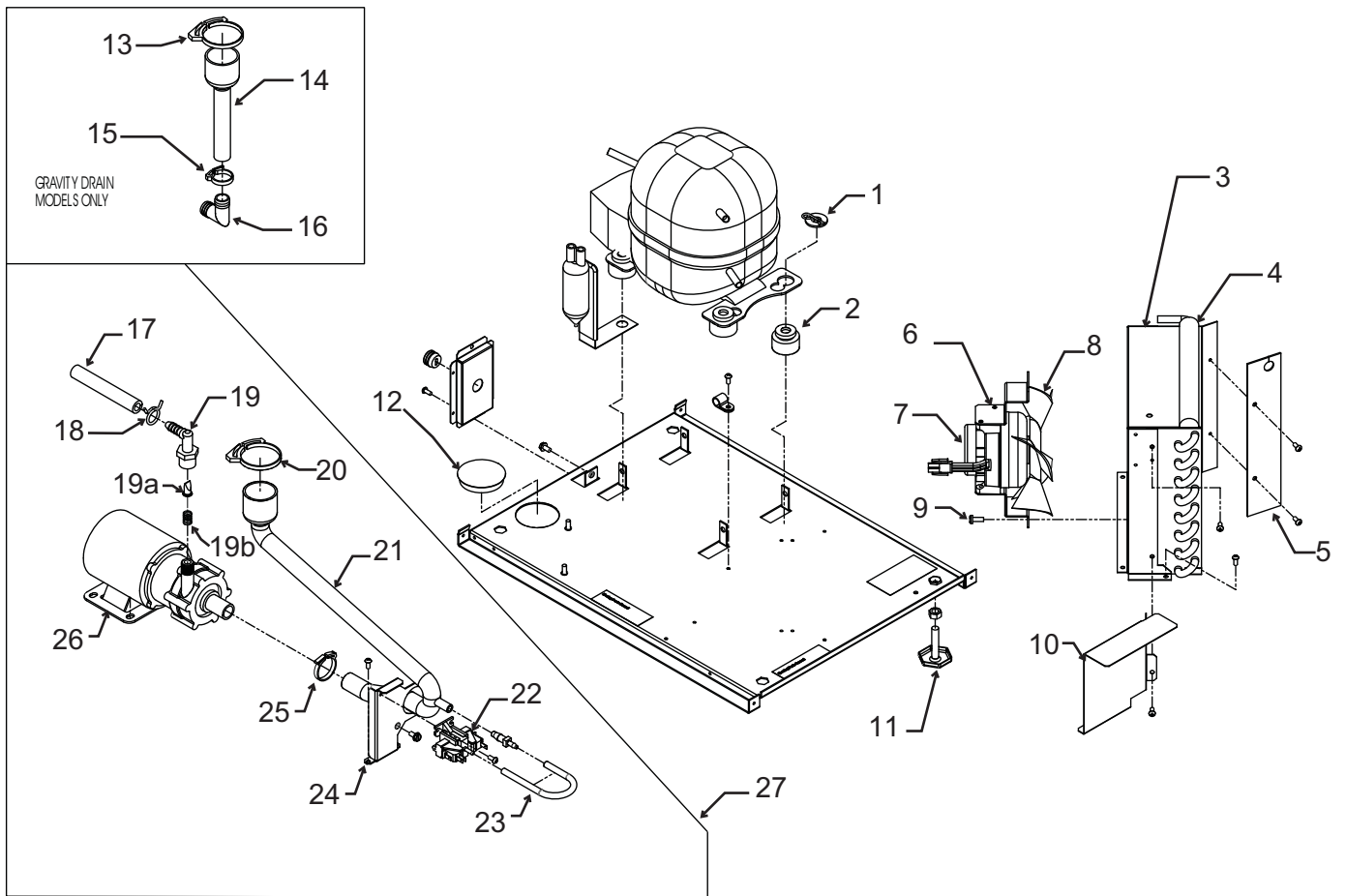

Item Number	Part Number	Description
1	1011448-68	Clip
1a	1011448-69	Washer
2	1011448-70	Grommet
3	1011448-71	Shroud
4	1011448-72	Gasket - order 1 & cut to fit
5	1011448-73	Air baffle
6	1011448-74	Fan motor bracket
7	1011448-75	Fan motor
8	1011448-76	Fan blade
9	1011448-77	Screw
10	1011448-78	Pump model rain shield
11	1011448-79	Leg leveler
12	1011448-80	Hole plug
13	1011448-81	Hose clamp
14	1011448-82	Drain hose
15	1011447-07	Hose clamp
16	1011448-83	Elbow
17	1011448-84	Discharge hose
18	1011448-85	Hose clamp
19	1011448-86	Elbow
20	1011448-87	Hose clamp
21	1011448-88	Drain tube
22	1011448-89	Pressure switch
23	1011448-90	Switch hose
24	1011448-91	Switch bracket
25	1011448-81	Hose clamp
26	1011448-92	Pump & motor only
27	KPU090	Pump kit

Service Parts

Ice Making Section

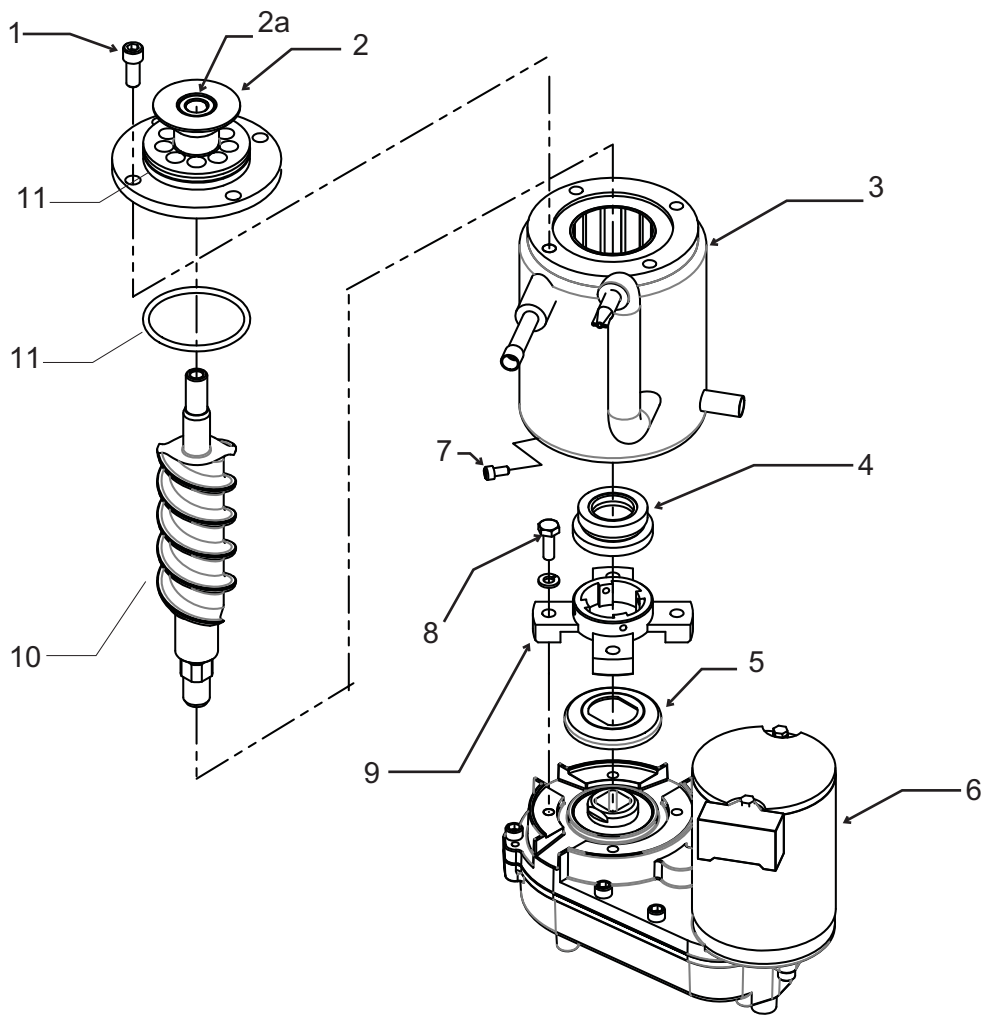

Item Number	Part Number	Description
1	1011380-44	Cap screw
2	1011448-93	Breaker w/bearing
2a	1011448-94	Bearing only
3	1011448-62	Evaporator
4	1011448-95	Water seal
5	1011448-96	Water shed
6	1011448-97	Gear reducer complete
6a	02-4580-22	Motor*
6b	02-4580-23	Capacitor*
7	1011448-100	Cap screw
8	1011448-101	Cap screw
9	1011448-102	Adapter
10	1011448-103	Auger
11	1011448-104	O-ring

* Must connect wires correctly. See label on motor.

Service Parts

Control System

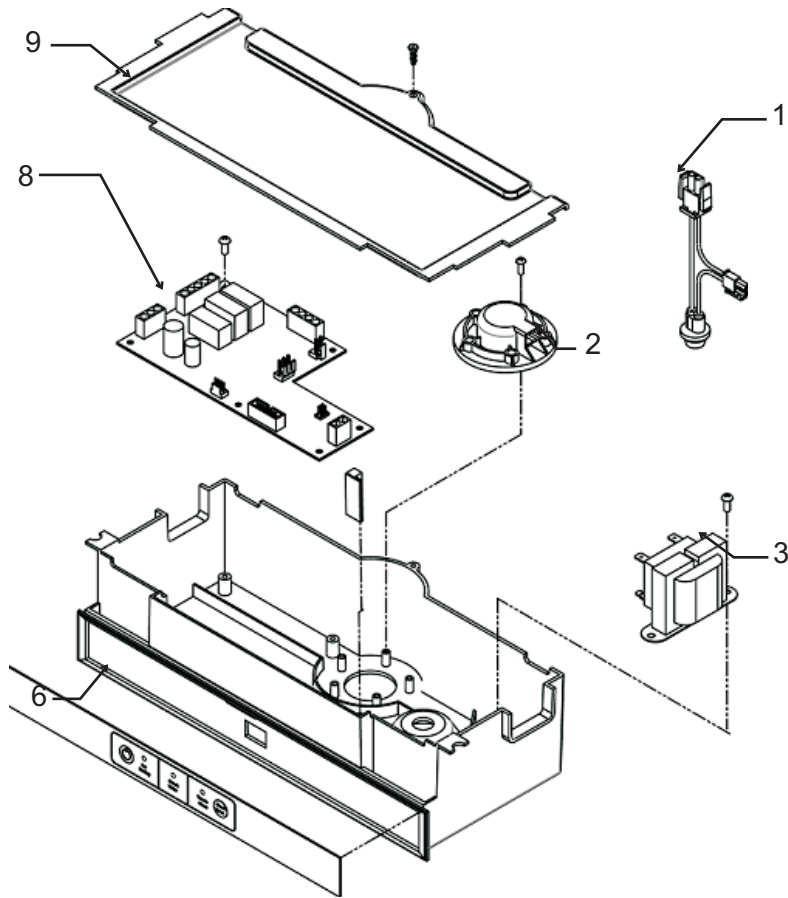

Item Number	Part Number	Description
1	NA	Harness, bin light
2	1011448-106	Ice level sensor
3	1011448-107	Transformer
6	1011448-108	Control panel
8	1011448-109	Controller
9	1011448-110	Cover

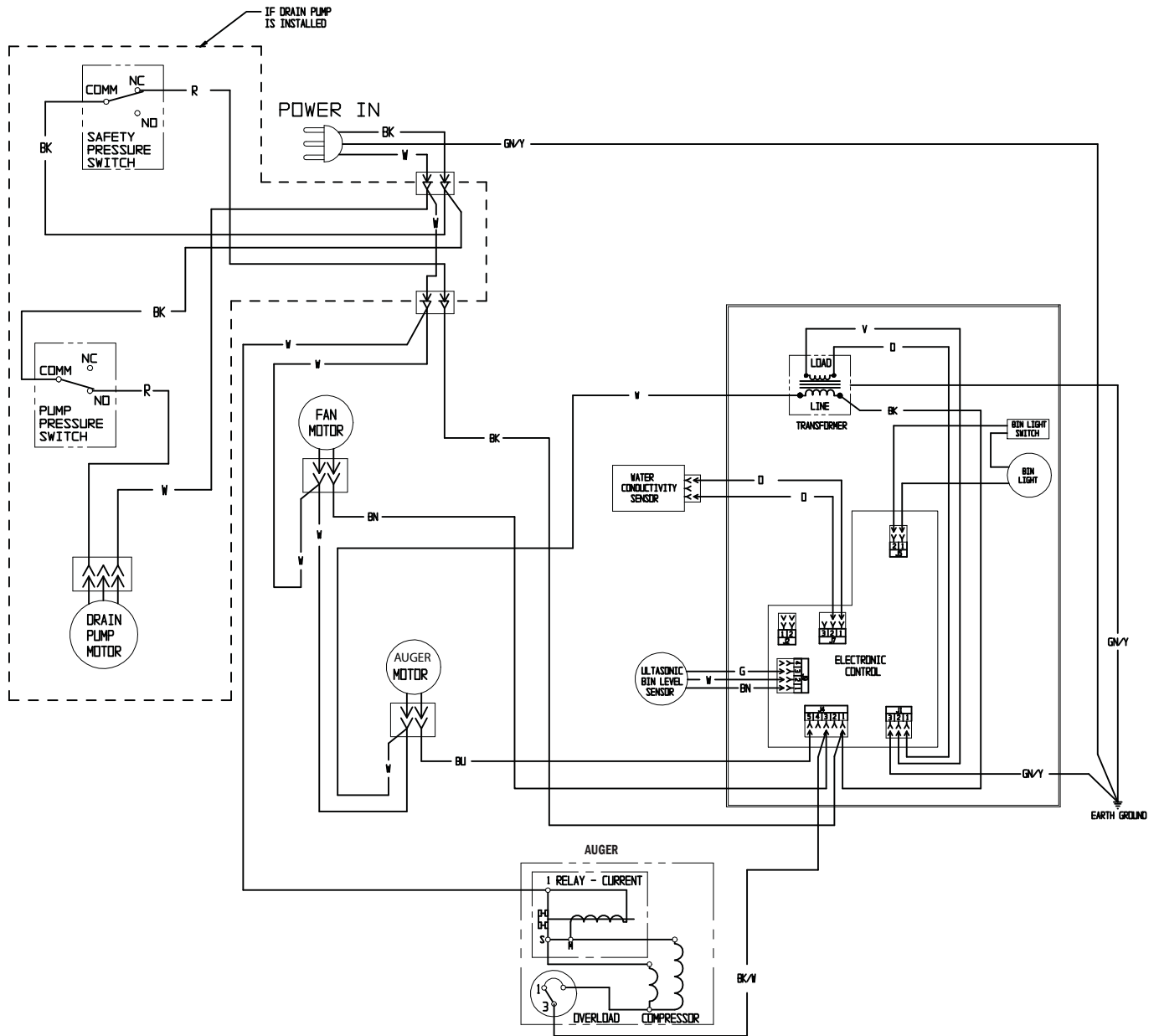

Service Parts Schematic Diagram

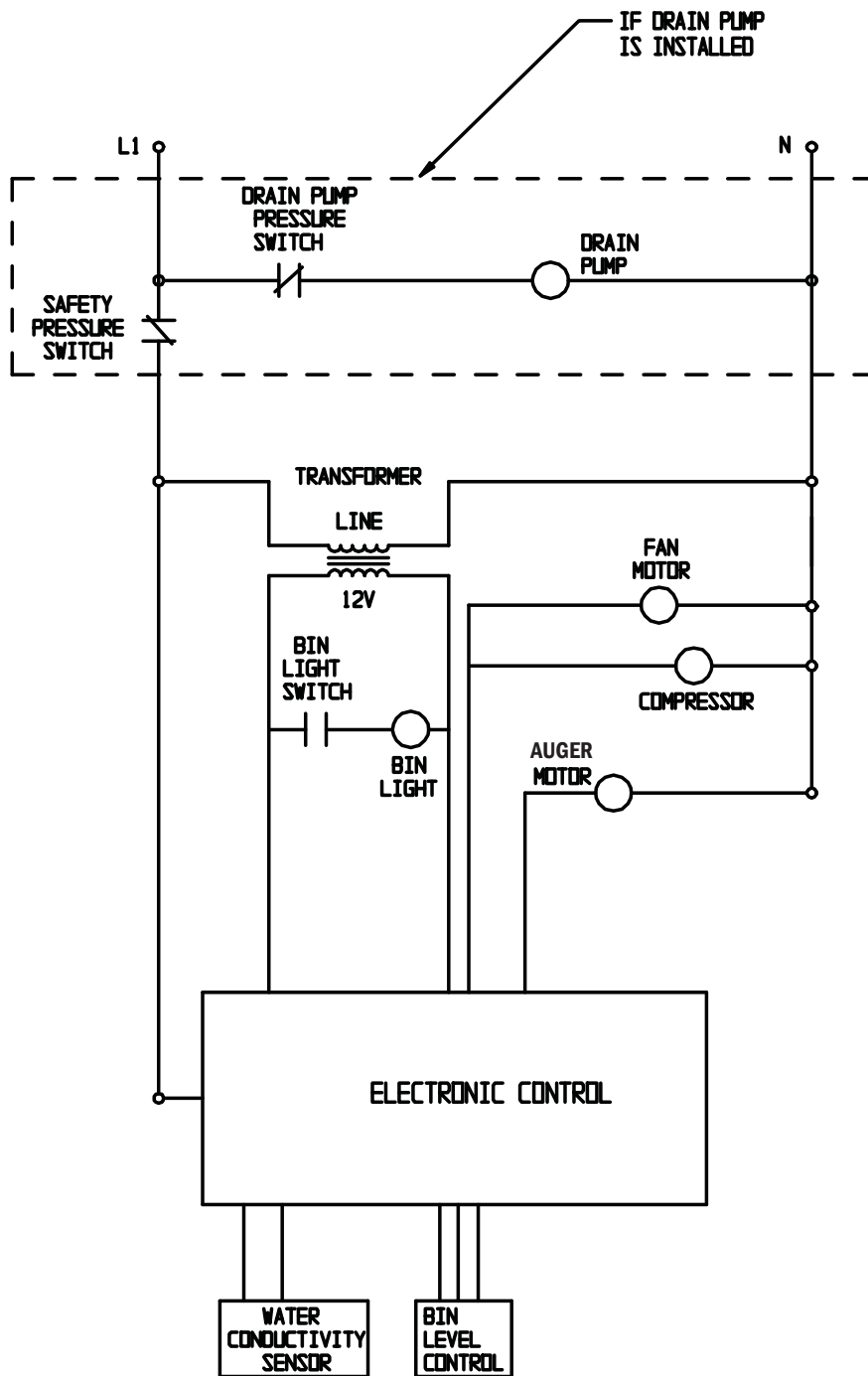

SWITCHES ON THIS UNIT
SHOWN IN FREEZE CYCLE
WITH DRAIN PUMP IN OPERATION
AND BIN DOOR CLOSED

Ice-O-Matic