

For missing parts or questions
Call 1-800-652-2321

9W Lawn Roller

OPERATION

Though most rollers are filled with water, we recommend adding Ethylene Glycol Anti-Freeze with the water. This will protect the tank from damage during cold weather. It is also recommended that the anti-freeze used, contain a rust inhibitor to protect the inside of the tank against rust. If the roller is filled with water only, it must be drained whenever the temperature drops below 32 degrees F. (0 degrees C.). The roller weighs approximately 400 pounds when filled. Sand can also be used in roller.

ASSEMBLY INSTRUCTIONS

1. Attach hub (3) to each of the side bars (6) with two 5/16" bolts (7) and 5/16" nuts (8).
2. Slide these assemblies over the axle, add flat washer (5) and lock in place by inserting and spreading ends of the cotter pins (4).
3. Add hitch tube (12) to side bars using 5/16" bolts (14) and 5/16" nuts (8).
4. Add clevis bars (13) to hitch tube with 5/16" bolts (14) and 5/16" nuts (8).

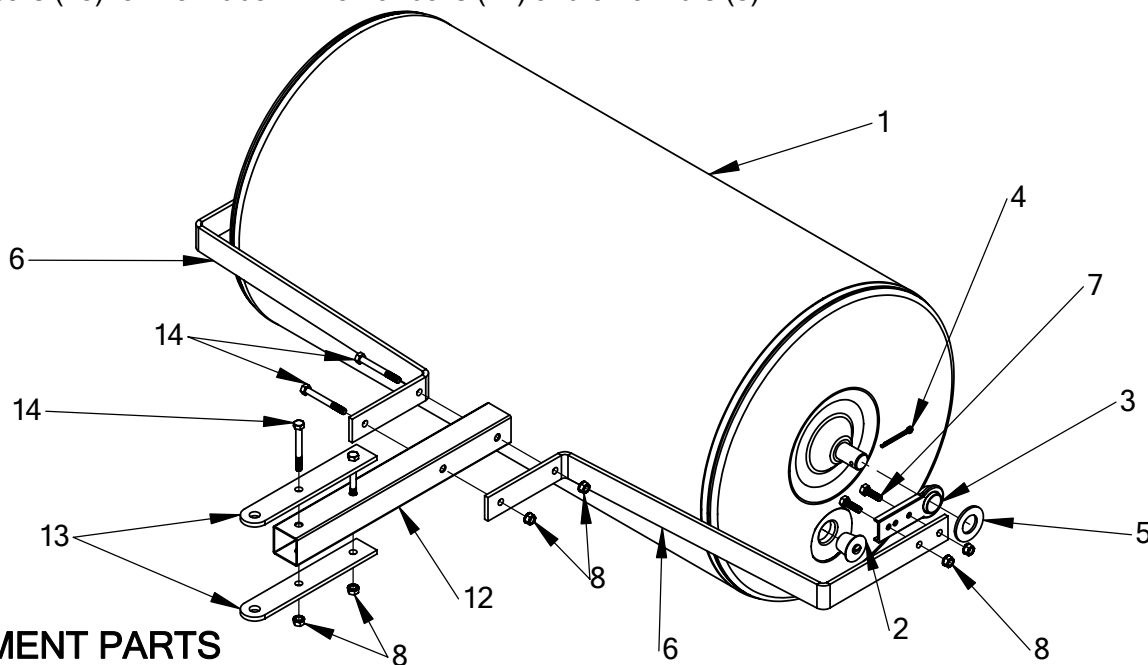

REPLACEMENT PARTS

PART NO.	REF. NO.	AMT.	DESCRIPTION	PART NO.	REF. NO.	AMT.	DESCRIPTION
9W-01A	1	1	DRUM ASSEMBLY	9W-07	7	4	HEX BOLT 5/16"-18 X 1"
48T-02A	2	1	PLUG	9W-08A	8	8	NUT 5/16"-18 KEPS
9W-03	3	2	SLEEVE BUSHING	48T-12A	12	1	HITCH TUBE
48T-04	4	2	COTTER PIN	48T-13A	13	2	CLEVIS BAR
48T-05	5	2	1" AXLE WASHER	9W-14	14	4	HEX BOLT 5/16"-18 X 2 3/4"
9W-06A	6	2	SIDE BAR				

FULL ONE-YEAR WARRANTY

If this product fails due to a defect in material or workmanship within one year from the date of purchase, Ohio Steel will at its option repair or replace it free of charge. ***Proof of purchase required.***

This warranty does not cover:

- Repairs necessary because of operator abuse or negligence.
- Equipment use for commercial or rental purposes.

Contact Ohio Steel to arrange for product repair, or return this product to place of purchase for replacement.

This warranty gives you specific legal rights, and you may also have other rights which vary from state to state. This Warranty applies only while this product is in use in the United States.

When ordering replacement parts, Please include part numbers and description.