

# *Slant/Fin*<sup>®</sup>

# LIBERTY<sup>®</sup> II

The world class oil-fired boiler

There's no better built oil-fired boiler than Liberty. Every component we use in the Liberty boiler is of the highest quality. Heat exchanger sections, for example, are made of only the finest cast iron, finished to exact specifications on automated high precision machining centers. Final assembly of each boiler is performed by hand.

Multiple checks are made for quality and overall boiler integrity. Every boiler section, for instance, is tested under pressure at least 8 times the normal residential operating pressure. Repetitive testing -- individual sections, assembled heat exchanger and completed boiler -- ensure the leak-free integrity of every boiler shipped.

**Burner performance optimized for each specific model. Every burner factory tested.**

The Liberty boiler is equipped with an advanced design Beckett oil burner. The burner for each Liberty boiler is custom manufactured to Slant/Fin specifications. It is engineered for each specific model to provide smooth, clean, efficient operation under all job conditions. The flame is up to 200°F hotter and up to 35% more efficient than older non-retention head burners.

For reliability, every burner is factory tested before shipping. It's given a full combustion test and fine tuned for optimal performance on the specific size boiler it is mounted on. Final adjustments are easily made by the installer, if necessary, based on the unique chimney draft conditions of each individual house.

**For dependability, metal push nipples; name brand controls and circulator pump**

Slant/Fin uses only metal push nipples that expand and contract with the individual boiler sections that they connect. The rubber gaskets that are substituted for push nipples in many other boilers could deteriorate. This could result in water leaking from the boiler and major repair bills.

Dependable performance is further ensured with nationally known brands of controls and circulator pumps. All controls are mounted and fully wired. Steam models include float type or electronic low water cut-off.



**Lifetime limited warranty.** The Liberty boiler is engineered and built for a long, dependable life. Hot water models are covered under Slant/Fin's lifetime limited warranty. Steam models have a limited ten-year warranty. Contact Slant/Fin for details.



# Slant Fin LIBERTY II

The world class oil-fired boiler

In most boilers, the hot flue gases which rise from the combustion area must pass around the push nipples that join the heating sections. This results in uneven heat transfer, concentrations of soot buildup and undesirable draft loss.

Liberty's push nipples are located to the side, out of the way of the flue gases. This creates more uniform heat transfer, minimizes draft loss and reduces soot build-up.

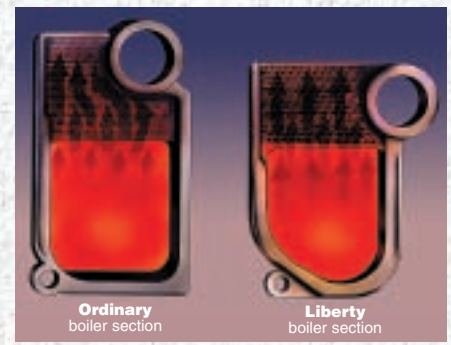

Boiler Model No.	I=B=R Burner Capacity Oil Input		D.O.E. Heating Capacity MBH		I=B=R Burner Net Ratings			I=B=R Chimney Size		A.F.U.E. %		Dimensions (inches)					Boiler section	Tankless Heater GPM*	
	GPH†	BTUH	Water	Steam	Water MBH‡	Steam MBH‡	Steam Sq. Ft.	Nom. Rect. x Height§ (in x in x ft)	I.D.Round x Height (in x ft)	Water	Steam	Boiler Length "A"	Front to Flue c "B"	Flue Dia. "C"	Return Circulator Flange "D"	Overall Length "E"		Water	Steam
LD-30H	1.00	140,000	121	—	105	—	—	8 x 8 x 15	6 x 15	86.00	—	14%	10½	6	1¼	27%	3	3.00	—
LD-30*	1.10	154,000	134	134	117	101	421	8 x 8 x 15	6 x 15	84.85	84.15	14%	10½	6	1¼	27%	3	3.20	3.00
	1.25	175,000	151	—	131	—	—	8 x 8 x 15	6 x 15	83.50	—	14%	10½	6	1¼	27%	3	3.40	—
LD-40H	1.50	210,000	182	179	158	134	558	8 x 8 x 15	6 x 15	86.00	84.00	18%	11¾	7	1¼	31	4	3.80	3.40
LD-40*	1.60	224,000	195	195	170	146	608	8 x 8 x 15	7 x 15	84.45	83.80	18%	11¾	7	1¼	31	4	3.90	3.50
	1.80	252,000	218	—	190	—	—	8 x 8 x 15	7 x 15	83.33	—	18%	11¾	7	1¼	31	4	4.15	—

\* Add Suffix: (P)Packaged water boiler less tankless heater, (PT)Packaged water boiler with tankless heater, (PPT)Packaged water boiler with provision for tankless heater, (PZ)Packaged steam boiler less tankless heater, (PZT)Packaged steam boiler with tankless heater.  
 † Ratings apply to the use of light oil at 140,000 Btu per gallon, and a .02% draft (negative pressure) over the fire.  
 ‡ The net I=B=R output ratings shown are based on an allowance for piping and pickup of 1.15 (water) or 1.33 (steam). D.O.E. capacity gross output is divided by the allowance to obtain net rating.  
 § The manufacturer should be consulted before selecting a boiler for unusual piping and pickup requirements such as intermittent system operation, extensive piping, etc.  
 ¶ Nominal clay tile liner dimensions.  
 \* Tankless heater rating based on intermittent draw.  
 † Water boiler models LD-30 and LD-40 have two firing rates. The boiler is factory shipped at the lower firing rate. To obtain the higher firing rate, refer to the Liberty boiler installation instructions for the appropriate field adjustments.  
 # I.B.R. gross output  
 Δ Collar is oblong, will fit 6" diameter nominal connector.

NOTE: All boilers under 300,000 Btu/h input are tested and rated for capacity under the U.S. Department of Energy (D.O.E.) Test Procedures for Boilers.

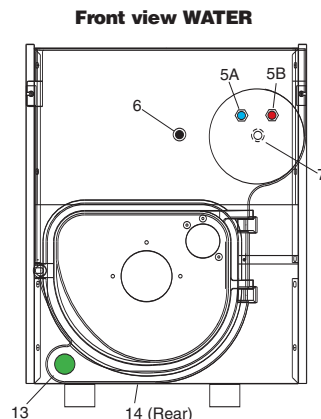
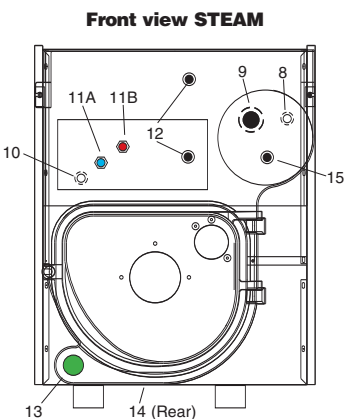
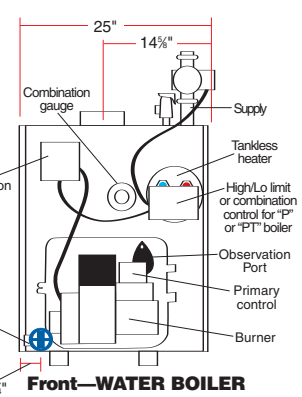
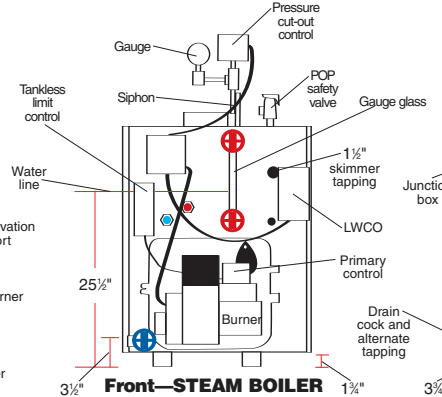
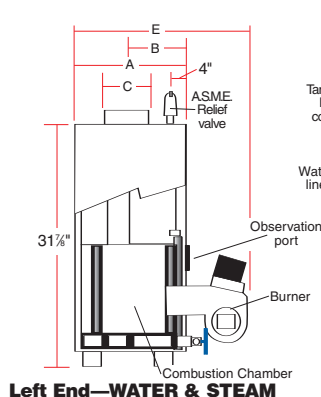
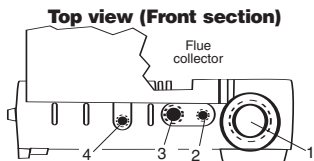

Tapping Location	STEAM BOILER	WATER BOILER
1	3" supply	1½" supply
1A	2" supply tapping (rear section of L-50, L-60 & L-70 models only)	—
2	Second ¼" siphon, pressure gauge & pressure cut-out	¾" air vent or expansion tank
3	¾" steam safety valve	¾" water relief valve
4	¼" siphon, pressure gauge & pressure cut-out	—
5A	—	½" tankless inlet
5B	—	½" tankless outlet
6	—	¼" pressure temp. gauge
7	—	½" hi limit, hi/lo or comb. control
8	¾" low water cut-off, alternate	—
9	1½" skimmer tapping	—
10	½" low limit for tankless	—
11A	½" tankless inlet	—
11B	½" tankless outlet	—
12	½" steam gauge glass & 67 LWCO	—
13	1½" return & ¾" drain cock	1½" return & ¾" drain cock
14	1½" condensate return	1½" alternate return
15	¾" zone tapping	—

# Slant/Fin

SLANT/FIN CORPORATION, Greenvale, NY 11548 • Phone: (516) 484-2600  
 FAX: (516) 484-5921 • In Canada: Slant/Fin LTD/LTEE, Mississauga, Ontario  
 www.slantfin.com

©Slant/Fin Corp. 2008. Printed in the U.S.A. 1008. Publication No. LD-10.